

Type 2 surge protection plug - VAL-SEC-T2-350VF-P - 2909596

Please be informed that the data shown in this PDF Document is generated from our Online Catalog. Please find the complete data in the user's documentation. Our General Terms of Use for Downloads are valid (<http://phoenixcontact.com/download>)



Replacement plug free of leakage current for surge protective devices from the VALVETRAB SEC product range for L-N and L-PEN paths.

Your advantages

- ✓ Free of leakage current
- ✓ High-performance gas-filled surge arrester for N/PE protection
- ✓ Extremely narrow design, just 12 mm per position
- ✓ High continuous voltage of 350 V AC for 230/400 V AC networks with high voltage fluctuations
- ✓ Pluggable
- ✓ Low voltage protection level of 1.5 kV
- ✓ Optical, mechanical status indicator
- ✓ Plugs can be checked with CHECKMASTER 2



Key Commercial Data

Packing unit	1 pc
GTIN	 4 055626 371627
GTIN	4055626371627

Technical data

Dimensions

Height	46.4 mm
Width	11.7 mm
Depth	59.4 mm
Horizontal pitch	0.6 Div.

Ambient conditions

Degree of protection	IP20
Ambient temperature (operation)	-40 °C ... 80 °C
Ambient temperature (storage/transport)	-40 °C ... 80 °C

Type 2 surge protection plug - VAL-SEC-T2-350VF-P - 2909596

Technical data

Ambient conditions

Altitude	≤ 2000 m (amsl (above mean sea level))
Permissible humidity (operation)	5 % ... 95 %

General

IEC test classification	II
	T2
EN type	T2
IEC power supply system	TN
	TT
Mode of protection	L-N
	L-PEN
Mounting type	on base element
Color	light grey RAL 7035
Housing material	PA 6.6-FR 20 % GF
	PBT-FR
Degree of pollution	2
Flammability rating according to UL 94	V-0
Type	Male
Number of positions	1
Surge protection fault message	optical

Protective circuit

Nominal voltage U_N	240 V AC (TN)
	240 V AC (TT)
Nominal frequency f_N	50 Hz (60 Hz)
Maximum continuous voltage U_C	350 V AC
Nominal discharge current I_n (8/20) μ s	10 kA
Maximum discharge current I_{max} (8/20) μ s	20 kA
Short-circuit current rating I_{SCCR}	50 kA
Voltage protection level U_p	≤ 1.5 kV
Residual voltage U_{res}	≤ 1.35 kV (at I_n)
	≤ 1.1 kV (at 5 kA)
	≤ 0.95 kV (at 2 kA)
	≤ 0.9 kV (at 1 kA)
Front of wave sparkover voltage at 6 kV (1.2/50) μ s	≤ 1.5 kV
TOV behavior at U_T	457 V AC (5 s / withstand mode)
	457 V AC (120 min / withstand mode)
Response time t_A	≤ 100 ns
Max. backup fuse with branch wiring	200 A (gG)

Connection data

Connection method	pluggable
-------------------	-----------

Type 2 surge protection plug - VAL-SEC-T2-350VF-P - 2909596

Technical data

Standards and Regulations

Standards/regulations	IEC 61643-11 2011
	EN 61643-11 2012

Environmental Product Compliance

China RoHS	Environmentally Friendly Use Period = 50 years
	For details about hazardous substances go to tab "Downloads", Category "Manufacturer's declaration"

Drawings

Circuit diagram



Type 2 surge protection plug - VAL-SEC-T2-350VF-P - 2909596

Dimensional drawing

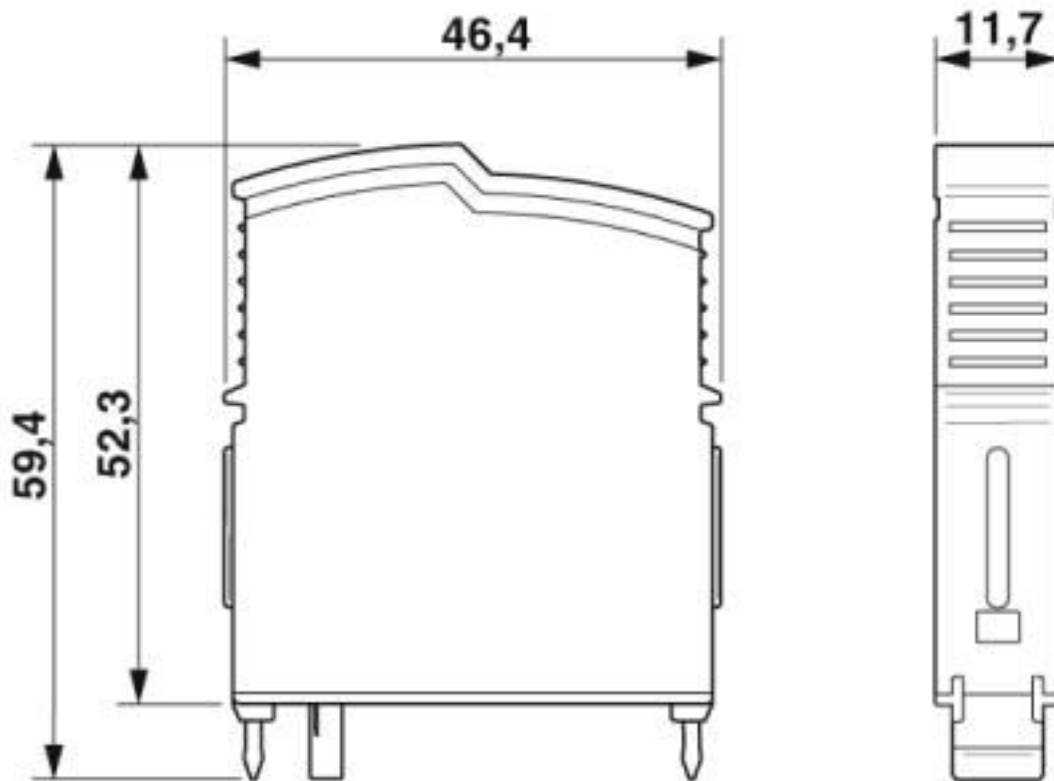

Classifications

eCl@ss

eCl@ss 10.0.1	27130890
eCl@ss 5.1	27130801
eCl@ss 6.0	27130800
eCl@ss 7.0	27130805
eCl@ss 8.0	27130890
eCl@ss 9.0	27130890

ETIM

ETIM 5.0	EC002496
ETIM 6.0	EC000941
ETIM 7.0	EC000941

UNSPSC

UNSPSC 13.2	39121620
UNSPSC 18.0	39121620
UNSPSC 19.0	39121620
UNSPSC 20.0	39121620
UNSPSC 21.0	39121620

Type 2 surge protection plug - VAL-SEC-T2-350VF-P - 2909596

Approvals

Approvals

Approvals

EAC

Ex Approvals

Approval details

EAC		RU C- DE.*09.B.00169
-----	--	-------------------------

Accessories

Accessories

Device marking

Label - EML (20XE)R - 0803452



Label, Roll, white, unlabeled, can be labeled with: THERMOMARK ROLLMASTER 300/600, THERMOMARK X1.2, THERMOMARK ROLL X1, THERMOMARK ROLL 2.0, THERMOMARK ROLL, mounting type: adhesive, lettering field size: continuous x 20#mm

Label - EML (20XE)R YE - 0803453



Label, Roll, yellow, unlabeled, can be labeled with: THERMOMARK ROLLMASTER 300/600, THERMOMARK X1.2, THERMOMARK ROLL X1, THERMOMARK ROLL 2.0, THERMOMARK ROLL, mounting type: adhesive, lettering field size: continuous x 20#mm

Marker pen

Marker pen - B-STIFT - 1051993



Marker pen, for manual labeling of unprinted Zack strips, smear-proof and waterproof, line thickness 0.5 mm

Phoenix Contact 2020 © - all rights reserved
<http://www.phoenixcontact.com>

PHOENIX CONTACT GmbH & Co. KG
Flachsmarktstr. 8
32825 Blomberg
Germany
Tel. +49 5235 300
Fax +49 5235 3 41200
<http://www.phoenixcontact.com>

Mouser Electronics

Authorized Distributor

Click to View Pricing, Inventory, Delivery & Lifecycle Information:

[Phoenix Contact:](#)

[2909596](#)