

# Hybrid motor starter - ELR H5-IS-PT- 24DC/500AC-9-P - 2909567

Please be informed that the data shown in this PDF Document is generated from our Online Catalog. Please find the complete data in the user's documentation. Our General Terms of Use for Downloads are valid (<http://phoenixcontact.com/download>)



Hybrid motor starter as an alternative to a conventional reversing contactor. Reverses 3~ AC motors up to 9 A, provides motor protection and emergency stop up to SIL 3/PL e. Group shut-down, supply, and relay extension possible via DIN rail connector.

## Product Description

The modular 3-phase hybrid motor starter with reversing function and current monitoring provides the following functions:

- Forward running
- Reverse running
- Motor overload protection
- Emergency stop to performance level PLe (TÜV certified)

Additional advantages are provided by using the DIN rail connector adapter (Order No. 2203861):

- Emergency stop of the enable signal is also possible via the DIN rail connector, e.g. via a safety relay (PSR DC38...)
- Power can also be supplied via the DIN rail connector by a system power supply (e. g., MINI-SYS-PS...) or via the PCB connector IMC 1,5/ 5-ST-3,81, Order No. 1857919
- Optional relay module (e. g., EM-2RSC/21AU-R/L-P, Order No. 2908701) provides additional status information

Thanks to the internal interlocking circuit and load wiring, wiring expense is reduced to a minimum.



## Key Commercial Data

Packing unit	1 pc
GTIN	
GTIN	4055626425498

## Technical data

### Dimensions

Width	22.5 mm
Height	107.5 mm
Depth	114 mm

### Ambient conditions

Ambient temperature (operation)	-25 °C ... 70 °C (observe derating)
Ambient temperature (storage/transport)	-40 °C ... 80 °C
Maximum altitude	≤ 2000 m
Degree of protection	IP20

# Hybrid motor starter - ELR H5-IS-PT- 24DC/500AC-9-P - 2909567

## Technical data

### Device supply

Rated control circuit supply voltage $U_s$	24 V DC
Control supply voltage range	19.2 V DC ... 30 V DC
Rated control supply current $I_s$	60 mA
Type of protection	Surge protection
	Reverse polarity protection

### Input data

Input name	Control input: right/left and enable input
Note	The enable input is compatible with signals with blanking (semiconductor output signals with test pulse with max. 3 ms duration), unblanking pulses of max. 4 ms are tolerated without adversely affecting the safety function.
Rated actuating voltage $U_c$	24 V DC
Triggering voltage range	19.2 V DC ... 30 V DC
Rated actuating current $I_c$	7 mA
Switching threshold	9.6 V ("0" signal)
	19.2 V ("1" signal)
Switching level	< 5 V DC (For EMERGENCY STOP)
Typical turn-off time	< 30 ms
Type of protection	Reverse polarity protection

### Output data load output

Output name	AC output
Rated operating voltage $U_e$	500 V AC
Operating voltage range	42 V AC ... 550 V AC
Rated operating current $I_e$	9 A (AC-51)
	7 A (AC-53a)
Mains frequency	50/60 Hz
Load current range	1.5 A ... 9 A
Trigger characteristic in acc. with IEC 60947-4-2	Class 10 ( $\leq 3$ A)
Cooling time	20 min. (for auto reset)
Leakage current	0 mA
Type of protection	Surge protection

### Output data reply output

Output name	Acknowledge output
Note	Confirmation: floating change-over contact, signal contact
Contact type	1 PDT
Switching capacity according to IEC 60947-5-1	2 A (24 V, DC13)

### Overspeed tripping

Operate threshold	> 60 A
Response time	< 0.5 s

# Hybrid motor starter - ELR H5-IS-PT- 24DC/500AC-9-P - 2909567

## Technical data

### General

Switching frequency	≤ 2 Hz (Load-dependent)
Mounting position	vertical (horizontal DIN rail, motor output below)
Mounting type	DIN rail mounting
Assembly instructions	alignable, for spacing see derating
Operating mode	100% operating factor
Maximum power dissipation	7 W
Minimum power dissipation	0.88 W
Operating voltage display	Green LED
Status display	Yellow LED
Indication	Red LED

### Connection data

Connection name	Control circuits
Connection method	Push-in connection
Stripping length	10 mm
Conductor cross section solid	0.2 mm <sup>2</sup> ... 2.5 mm <sup>2</sup>
Conductor cross section flexible	0.2 mm <sup>2</sup> ... 2.5 mm <sup>2</sup>
Conductor cross section AWG	24 ... 14

### Connection data 2

Connection name	Load circuit
Connection method	Push-in connection
Stripping length	10 mm
Conductor cross section solid	0.2 mm <sup>2</sup> ... 2.5 mm <sup>2</sup>
Conductor cross section flexible	0.2 mm <sup>2</sup> ... 2.5 mm <sup>2</sup>
Conductor cross section AWG	24 ... 14

### Insulation characteristics

Rated insulation voltage	550 V
Rated surge voltage	6 kV
Overvoltage category	III
Degree of pollution	2
Designation	Insulation characteristics between the control input and control supply voltage, and auxiliary circuit to the main circuit
Insulation	Safe isolation (IEC 60947-1)
Designation	Isolation characteristics between the control input and control supply voltage to auxiliary circuit
Insulation	Safe isolation (IEC 60947-1) in the auxiliary circuit ≤ 300 V AC
	Safe isolation (EN 50178) in the auxiliary circuit ≤ 300 V AC

### Standards and Regulations

Designation	Standards/regulations
Standards/regulations	EN 60947-1
	EN 60947-4-2

# Hybrid motor starter - ELR H5-IS-PT- 24DC/500AC-9-P - 2909567

## Technical data

### Standards and Regulations

	EN ISO 13849
	IEC 62061
	IEC 61508

### Conformance/approvals

Designation	UL approval
Certificate	NLDX.E228652
	NRNT.E172140
Designation	Safety Integrity Level (SIL, IEC 61508)
Identification	≤ 3
Additional text	Safe shutdown
Designation	Safety Integrity Level (SIL, IEC 61508)
Identification	2
Additional text	Motor protection
Designation	Performance Level (ISO 13849)
Identification	≤ e
Additional text	Safe shutdown
Designation	Category (ISO 13849)
Identification	≤ 3
Additional text	Safe shutdown

### UL data

SCCR	100 kA (480 V AC (fuse: 30 A class CC/30 A class J (high fault)))
	5 kA (480 V AC (fuse: 20 A RK5 (standard fault)))
FLA	7.6 A (480 V AC)
Group installation	20 A (class RK5, SCCR 5kA (480 V AC), #24 - 14 AWG max. solid and stranded)
	30 A (class CC or J, SCCR 100kA (480 V AC), #24 - 14 AWG max. solid and stranded)
Category code	NLDX / NRNT
Horsepower ratings	2 hp (120 V AC / 208 V AC)
	5 hp (277 V AC / 480 V AC)
Ambient temperature (operation)	-25 °C ... 55 °C

### Environmental Product Compliance

REACH SVHC	Lead 7439-92-1
China RoHS	Environmentally Friendly Use Period = 50 years
	For details about hazardous substances go to tab "Downloads", Category "Manufacturer's declaration"

## Drawings

# Hybrid motor starter - ELR H5-IS-PT- 24DC/500AC-9-P - 2909567

Block diagram

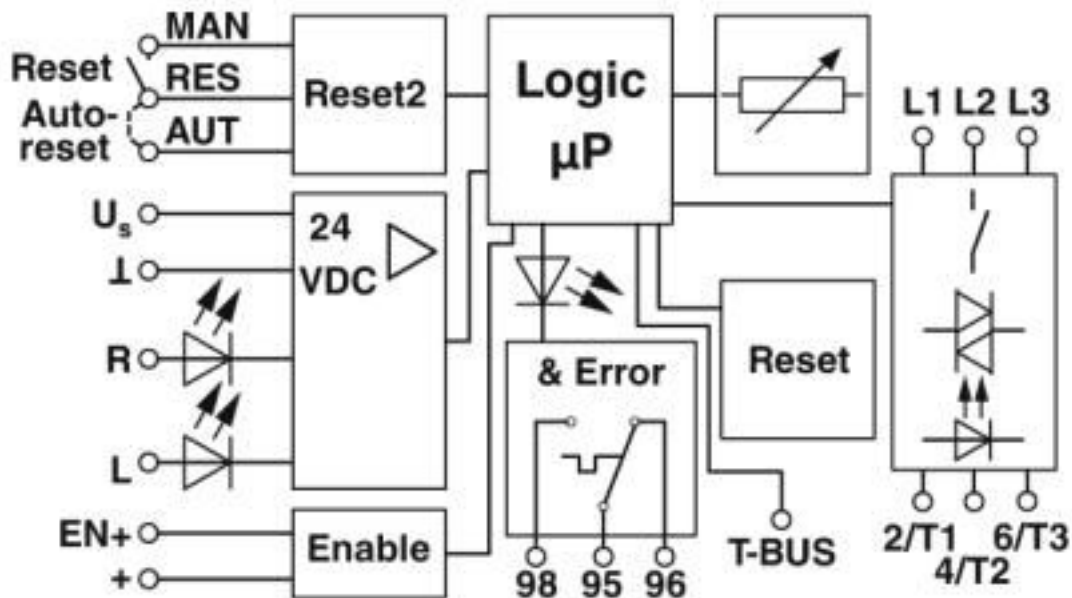

## Classifications

eCl@ss

eCl@ss 10.0.1	27370905
eCl@ss 4.0	27021100
eCl@ss 4.1	27021100
eCl@ss 5.0	27024000
eCl@ss 5.1	27024000
eCl@ss 6.0	27024000
eCl@ss 7.0	27024002
eCl@ss 8.0	27024002
eCl@ss 9.0	27370905

ETIM

ETIM 2.0	EC001037
ETIM 3.0	EC001037
ETIM 4.0	EC001037
ETIM 5.0	EC001037
ETIM 6.0	EC001037
ETIM 7.0	EC001037

## Approvals

Approvals

# Hybrid motor starter - ELR H5-IS-PT- 24DC/500AC-9-P - 2909567

## Approvals

Approvals

UL Listed / cUL Listed / UL Listed / IECCE CB Scheme / cUL Listed / EAC

Ex Approvals

## Approval details

UL Listed		<a href="http://database.ul.com/cgi-bin/XYV/template/LISEXT/1FRAME/index.htm">http://database.ul.com/cgi-bin/XYV/template/LISEXT/1FRAME/index.htm</a>	FILE E 228652
cUL Listed		<a href="http://database.ul.com/cgi-bin/XYV/template/LISEXT/1FRAME/index.htm">http://database.ul.com/cgi-bin/XYV/template/LISEXT/1FRAME/index.htm</a>	FILE E 228652
UL Listed		<a href="http://database.ul.com/cgi-bin/XYV/template/LISEXT/1FRAME/index.htm">http://database.ul.com/cgi-bin/XYV/template/LISEXT/1FRAME/index.htm</a>	FILE E 172140
IECEE CB Scheme		<a href="http://www.iecee.org/">http://www.iecee.org/</a>	DE1-60807
cUL Listed		<a href="http://database.ul.com/cgi-bin/XYV/template/LISEXT/1FRAME/index.htm">http://database.ul.com/cgi-bin/XYV/template/LISEXT/1FRAME/index.htm</a>	FILE E 172140
EAC			RU*C- DE.*08.B.00520*

## Accessories

Accessories

Cover

Covering hood - BRIDGE COVER - 2906240



The BRIDGE COVER covering hood is used to cover unused plugs on the CONTACTRON bridge that may subsequently be used to extend the system. The hood can be used with the screw and Push-in version of the bridge.

# Hybrid motor starter - ELR H5-IS-PT- 24DC/500AC-9-P - 2909567

## Accessories

---

### DIN rail connector

DIN rail bus connectors - ME 17,5 TBUS 1,5/ 5-ST-3,81 GN - 2709561



DIN rail connector for DIN rail mounting. Universal for TBUS housing. Gold-plated contacts, 5-pos.

---

DIN rail bus connectors - ELR-TBUS-22,5-P - 2203861



Special DIN rail connector only suitable for ELR H...-P and EM-...-P.

---

DIN rail bus connectors - PSR-TBUS - 2890425



DIN rail connector for safety switching devices, for supplying/controlling/monitoring (depending on the module)

---

### Extension module

Extension module - EM-2RSC/21AU-R/L-P - 2908701



Relay extension module for ELR-...-P hybrid motor starters, feedback of forward and reverse running when control signal is present, screw connection, DIN rail connector included

---

Extension module - EM-2RPT/21AU-R/L-P - 2909573



Relay extension module for ELR-...-P hybrid motor starters, feedback of forward and reverse running when control signal is present, Push-in connection, DIN rail connector included

---

### Loop bridge

## Hybrid motor starter - ELR H5-IS-PT- 24DC/500AC-9-P - 2909567

### Accessories

#### Jumper - BRIDGE-PT 1 - 1161777



3-phase loop bridge for 1 CONTACTRON module, with Push-in connection and 22.5 mm housing width, connecting cable: 3 m

---

#### Jumper - BRIDGE-PT 2 - 2904490



3-phase loop bridge for 2 CONTACTRON modules, with Push-in connection and 22.5 mm housing width, connecting cable: 3 m

---

#### Jumper - BRIDGE-PT 3 - 2904491



3-phase loop bridge for 3 CONTACTRON modules, with Push-in connection and 22.5 mm housing width, connecting cable: 3 m

---

#### Jumper - BRIDGE-PT 4 - 2904492



3-phase loop bridge for 4 CONTACTRON modules, with Push-in connection and 22.5 mm housing width, connecting cable: 3 m

---

#### Jumper - BRIDGE-PT 5 - 2904493



3-phase loop bridge for 5 CONTACTRON modules, with Push-in connection and 22.5 mm housing width, connecting cable: 3 m

---



## Hybrid motor starter - ELR H5-IS-PT- 24DC/500AC-9-P - 2909567

### Accessories

Jumper - BRIDGE-PT 6 - 2904494



3-phase loop bridge for 6 CONTACTRON modules, with Push-in connection and 22.5 mm housing width, connecting cable: 3 m

---

Jumper - BRIDGE-PT 7 - 2904495



3-phase loop bridge for 7 CONTACTRON modules, with Push-in connection and 22.5 mm housing width, connecting cable: 3 m

---

Jumper - BRIDGE-PT 8 - 2904496



3-phase loop bridge for 8 CONTACTRON modules, with Push-in connection and 22.5 mm housing width, connecting cable: 3 m

---

Jumper - BRIDGE-PT 9 - 2904497



3-phase loop bridge for 9 CONTACTRON modules, with Push-in connection and 22.5 mm housing width, connecting cable: 3 m

---

Jumper - BRIDGE-PT 10 - 2904498



3-phase loop bridge for 10 CONTACTRON modules, with Push-in connection and 22.5 mm housing width, connecting cable: 3 m

---

## Hybrid motor starter - ELR H5-IS-PT- 24DC/500AC-9-P - 2909567

### Accessories

Jumper - BRIDGE-PT 1-1M - 1161778



3-phase loop bridge for 1 CONTACTRON module, with Push-in connection and 22.5 mm housing width, connecting cable: 1 m

---

Jumper - BRIDGE-PT-2-1M - 1049407



3-phase loop bridge for 2 CONTACTRON modules, with Push-in connection and 22.5 mm housing width, connecting cable: 1 m

---

Jumper - BRIDGE-PT-3-1M - 1049408



3-phase loop bridge for 3 CONTACTRON modules, with Push-in connection and 22.5 mm housing width, connecting cable: 1 m

---

Jumper - BRIDGE-PT-4-1M - 1049409



3-phase loop bridge for 4 CONTACTRON modules, with Push-in connection and 22.5 mm housing width, connecting cable: 1 m

---

Jumper - BRIDGE-PT-5-1M - 1049413



3-phase loop bridge for 5 CONTACTRON modules, with Push-in connection and 22.5 mm housing width, connecting cable: 1 m

---

## Hybrid motor starter - ELR H5-IS-PT- 24DC/500AC-9-P - 2909567

### Accessories

Jumper - BRIDGE-PT-2-2M/0,3M - 1107649



3-phase loop bridge for 2 CONTACTRON modules, with Push-in connection and 22.5 mm housing width, cable length between the modules: 0.3 m, connecting cable: 2 m

---

Jumper - BRIDGE-PT-3-2M/0,3M - 1107650



3-phase loop bridge for 3 CONTACTRON modules, with Push-in connection and 22.5 mm housing width, cable length between the modules: 0.3 m, connecting cable: 2 m

---

Jumper - BRIDGE-PT-4-2M/0,3M - 1107644



3-phase loop bridge for 4 CONTACTRON modules, with Push-in connection and 22.5 mm housing width, cable length between the modules: 0.3 m, connecting cable: 2 m

---

### Power supply

Power supply unit - MINI-SYS-PS-100-240AC/24DC/1.5 - 2866983



Primary-switched MINI POWER supply for DIN rail mounting, input: 1-phase, output: 24 V DC/1.5 A

---

### Safety relays

Safety relays - PSR-MC38-2NO-1DO-24DC-SC - 1009831



Safety relay for emergency stop, safety doors and light grids up to SILCL 3, Cat. 4, PL e, 1- or 2-channel operation, automatic or manual, monitored start, 2 enabling current paths, 1 signal output, TBUS interface,  $U_S = 24$  V DC, pluggable screw terminal block

---

## Hybrid motor starter - ELR H5-IS-PT- 24DC/500AC-9-P - 2909567

### Accessories

Safety relays - PSR-MC38-2NO-1DO-24DC-PI - 1009832



Safety relay for emergency stop, safety doors and light grids up to SILCL 3, Cat. 4, PL e, 1- or 2-channel operation, automatic or manual, monitored start, 2 enabling current paths, 1 signal output, TBUS interface,  $U_s = 24 \text{ V DC}$ , pluggable push-in terminal

---

Phoenix Contact 2020 © - all rights reserved  
<http://www.phoenixcontact.com>

PHOENIX CONTACT GmbH & Co. KG  
Flachsmarktstr. 8  
32825 Blomberg  
Germany  
Tel. +49 5235 300  
Fax +49 5235 3 41200  
<http://www.phoenixcontact.com>

# Mouser Electronics

Authorized Distributor

Click to View Pricing, Inventory, Delivery & Lifecycle Information:

[Phoenix Contact:](#)

[2909567](#)