

# Type 3 surge protection plug - PLT-SEC-T3-120-P-UT/PT - 2907922

Please be informed that the data shown in this PDF Document is generated from our Online Catalog. Please find the complete data in the user's documentation. Our General Terms of Use for Downloads are valid (<http://phoenixcontact.com/download>)



Replacement plug for type 2/3 surge protection from the PLT-SEC-...-UT/PT product series. Nominal voltage 120 V.



## Key Commercial Data

Packing unit	10 pc
GTIN	 4 0 5 5 6 2 6 2 5 7 4 8 8
GTIN	4055626257488

## Technical data

### Dimensions

Height	46.7 mm
Width	17.5 mm
Depth	65.7 mm
Horizontal pitch	1 Div.

### Ambient conditions

Degree of protection	IP20
Ambient temperature (operation)	-40 °C ... 80 °C
Ambient temperature (storage/transport)	-40 °C ... 80 °C
Altitude	≤ 6000 m (amsl (above mean sea level))
Permissible humidity (operation)	5 % ... 95 %
Shock (operation)	30g (Half-sine / 11 ms / 3x ±X, ±Y, ±Z)
Vibration (operation)	5g (5 ... 500 Hz / 2.5 h / X, Y, Z)

### General

EN type	T2 / T3
IEC power supply system	TN-S
	TT
Number of ports	One

# Type 3 surge protection plug - PLT-SEC-T3-120-P-UT/PT - 2907922

## Technical data

### General

Mode of protection	L-N
	L-PE
	N-PE
Mounting type	on base element
Color	light grey RAL 7035
Housing material	PA 6.6-FR 20 % GF
	PA 6.6-FR
Degree of pollution	2
Flammability rating according to UL 94	V-0
Type	Male
Number of positions	2
Surge protection fault message	optical

### Protective circuit

Nominal voltage $U_N$	120 V AC (TN-S)
	120 V AC (TT)
Nominal frequency $f_N$	50 Hz (60 Hz)
Maximum continuous voltage $U_C$	150 V AC
Residual current $I_{PE}$	$\leq 5 \mu A$
Nominal discharge current $I_n$ (8/20) $\mu s$	5 kA
Standby power consumption $P_C$	$\leq 10.6 \text{ mVA (at } U_{REF})$
	$\leq 13.5 \text{ mVA (at } U_C)$
Reference test voltage $U_{REF}$	132 V AC
Max. discharge current $I_{max}$ (8/20) $\mu s$	10 kA
Combination wave $U_{OC}$	6 kV
Voltage protection level $U_p$ (L-N)	$\leq 0.75 \text{ kV (at } U_{OC})$
	$\leq 0.95 \text{ kV (at } I_n)$
Voltage protection level $U_p$ (L-PE)	$\leq 0.85 \text{ kV}$
Voltage protection level $U_p$ (N-PE)	$\leq 0.85 \text{ kV}$
TOV behavior at $U_T$ (L-N)	240 V AC (5 s / withstand mode)
	240 V AC (120 min / withstand mode)
TOV behavior at $U_T$ (L-PE)	240 V AC (5 s / withstand mode)
	240 V AC (120 min / withstand mode)
	1332 V AC (200 ms / safe failure mode)
TOV behavior at $U_T$ (N-PE)	1200 V AC (200 ms / safe failure mode)
Response time $t_A$ (L-N)	$\leq 25 \text{ ns}$
Response time $t_A$ (L-PE)	$\leq 100 \text{ ns}$
Response time $t_A$ (N-PE)	$\leq 100 \text{ ns}$
Short-circuit current rating $I_{SCCR}$	10 kA AC
Max. backup fuse with branch wiring	32 A (gG / B / C)

# Type 3 surge protection plug - PLT-SEC-T3-120-P-UT/PT - 2907922

## Technical data

### Additional technical data

Short-circuit current rating $I_{SCCR}$	0.25 kA DC (Without additional backup fuse in the DC branch wiring)
	5 kA DC (for 20 A gG / B backup fuse)
Maximum continuous voltage $U_C$	150 V DC
Residual voltage $U_{res}$ (L-N)	$\leq 0.68$ kV (at 2 kA)
	$\leq 0.75$ kV (at 3 kA)
	$\leq 0.64$ kV (at $U_{OC} = 4$ kV)
Residual voltage $U_{res}$ (L-PE)	$\leq 0.58$ kV (at 2 kA)
	$\leq 0.65$ kV (at 3 kA)
	$\leq 0.75$ kV (at $U_{OC} = 4$ kV)
Residual voltage $U_{res}$ (N-PE)	$\leq 0.58$ kV (at 2 kA)
	$\leq 0.65$ kV (at 3 kA)
	$\leq 0.75$ kV (at $U_{OC} = 4$ kV)
Mode of protection	(DC+) - (DC-)
	(DC+/DC-) - PE
IEC test classification (in accordance with IEC 61643-21)	D1
Impulse durability (line-line)	D1 - 500 A
Impulse durability (line-earth)	D1 - 500 A
Pulse discharge current $I_{imp}$ (10/350) $\mu$ s (line-line)	0.5 kA
Pulse discharge current $I_{imp}$ (10/350) $\mu$ s (line-earth)	0.5 kA

### Connection data

Connection method	pluggable
-------------------	-----------

### UL specifications

SPD Type	2CA
Maximum continuous operating voltage MCOV	150 V AC
	150 V DC
Nominal voltage	150 V DC
Rated load current $I_L$	20 A
Mode of protection	L-N
	L-G
	N-G
	(DC+) - (DC-)
	(DC+) - G
	(DC-) - G
Power distribution system	Single phase
	DC
Nominal frequency	50/60 Hz
Voltage protection rating VPR (L-N)	800 V
Voltage protection rating VPR (L-G)	900 V
Voltage protection rating VPR (N-G)	900 V

## Type 3 surge protection plug - PLT-SEC-T3-120-P-UT/PT - 2907922

### Technical data

#### UL specifications

Nominal discharge current $I_n$	5 kA
Short-circuit current rating (SCCR)	10 kA AC
	5 kA DC

#### Standards and Regulations

Standards/specifications	IEC 61643-11 2011
	EN 61643-11 2012

#### Environmental Product Compliance

China RoHS	Environmentally friendly use period: unlimited = EFUP-e
	No hazardous substances above threshold values

### Drawings

# Type 3 surge protection plug - PLT-SEC-T3-120-P-UT/PT - 2907922

Circuit diagram

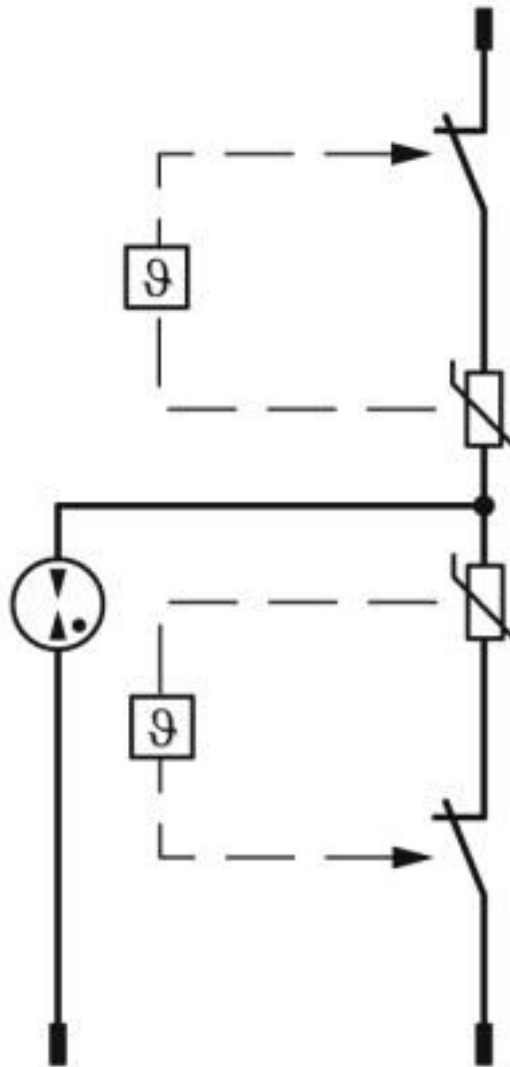

# Type 3 surge protection plug - PLT-SEC-T3-120-P-UT/PT - 2907922

Dimensional drawing

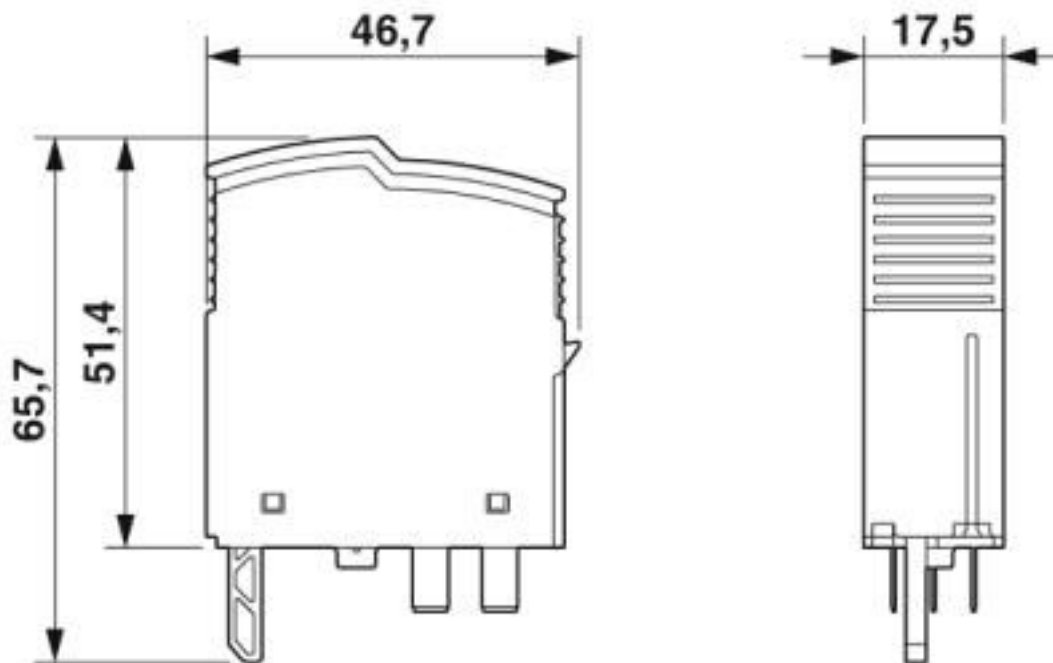

## Classifications

eCl@ss

eCl@ss 10.0.1	27130890
eCl@ss 6.0	27130800
eCl@ss 7.0	27130890
eCl@ss 8.0	27130890
eCl@ss 9.0	27130890

ETIM

ETIM 5.0	EC002496
ETIM 6.0	EC002497
ETIM 7.0	EC002497

## Approvals

Approvals

Approvals

DNV GL / CCA / UL Recognized / KEMA-KEUR / cUL Recognized / IECCEB Scheme / EAC / CSA / cULus Recognized

Ex Approvals

UL Recognized / cUL Recognized / cULus Recognized

# Type 3 surge protection plug - PLT-SEC-T3-120-P-UT/PT - 2907922

## Approvals

### Approval details

DNV GL		<a href="https://approvalfinder.dnvgl.com/">https://approvalfinder.dnvgl.com/</a>	TAE00002U7
CCA			NTR-NL 7676
UL Recognized		<a href="http://database.ul.com/cgi-bin/XYV/template/LISEXT/1FRAME/index.htm">http://database.ul.com/cgi-bin/XYV/template/LISEXT/1FRAME/index.htm</a>	FILE E 330181
KEMA-KEUR		<a href="http://www.dekra-certification.com">http://www.dekra-certification.com</a>	71-103027
cUL Recognized		<a href="http://database.ul.com/cgi-bin/XYV/template/LISEXT/1FRAME/index.htm">http://database.ul.com/cgi-bin/XYV/template/LISEXT/1FRAME/index.htm</a>	FILE E 330181
IECEE CB Scheme		<a href="http://www.iecee.org/">http://www.iecee.org/</a>	NL-51083
EAC			RU C-DE.*09.B.00169
CSA		<a href="http://www.csagroup.org/services-industries/product-listing/">http://www.csagroup.org/services-industries/product-listing/</a>	70194378
cULus Recognized			

Phoenix Contact 2020 © - all rights reserved  
<http://www.phoenixcontact.com>

PHOENIX CONTACT GmbH & Co. KG  
Flachmarktstr. 8  
32825 Blomberg  
Germany  
Tel. +49 5235 300  
Fax +49 5235 3 41200  
<http://www.phoenixcontact.com>



# Mouser Electronics

Authorized Distributor

Click to View Pricing, Inventory, Delivery & Lifecycle Information:

[Phoenix Contact:](#)

[2907922](#)