

Monitoring relay - EMD-BL-PTC-PT - 2906253

Please be informed that the data shown in this PDF Document is generated from our Online Catalog. Please find the complete data in the user's documentation. Our General Terms of Use for Downloads are valid (<http://phoenixcontact.com/download>)



Temperature monitoring of the motor winding (maximum 6 PTCs) for temperature sensors according to DIN 44081 and DIN 44082 with short-circuit monitoring of the thermistor circuit, with push-in connection.

Product Description

Safety and system availability requirements are constantly on the increase – across all industries. Processes are becoming more and more complex, not only in machine building and the chemical industry but also in building technology. The demands placed on energy technology are also constantly on the rise.

It is only by continuously monitoring key network and system parameters that error-free and therefore cost-effective operation can be achieved. Electronic monitoring relays from the EMD series are available for a wide range of monitoring tasks so that the consequences of errors can be avoided or kept within limits.

The operating states are signaled via color LEDs and any errors that occur can be sent to a controller via a floating contact or can shut down a section of the system. All device versions are equipped with response delays so that measured values outside the set monitoring range can be briefly tolerated.



Key Commercial Data

Packing unit	1 pc
GTIN	
GTIN	4055626053745

Technical data

Dimensions

Width	17.5 mm
Height	88 mm
Depth	65.5 mm

Ambient conditions

Ambient temperature (operation)	-25 °C ... 55 °C
Ambient temperature (storage/transport)	-25 °C ... 70 °C
Permissible humidity (operation)	15 % ... 85 %
Degree of protection	IP40 (Housing)
	IP20 (Connection terminal blocks)
Noise immunity	EN 61000-6-2

Monitoring relay - EMD-BL-PTC-PT - 2906253

Technical data

Input data

Maximum temperature coefficient	< 0.05 %/K
Function	Winding temperature monitoring
Basic accuracy	± 10 % (of scale end value)
Total cold resistance	≤ 1.5 kΩ
Response value	≥ 3.6 kΩ (Relay drops out)
Release value	≤ 1.6 kΩ (Relay picks up)
Short-circuit detection	< 20 Ω
Recovery time	> 300 ms

Contact side

Contact type	1 floating PDT
Maximum switching voltage	250 V AC (in acc. with IEC 60947-5-1)
Interrupting rating (ohmic load) max.	1250 VA (5 A / 250 V AC)
Output fuse	5 A (fast-blow)

Power supply

Supply voltage	230 V AC (-15 % ... +10 %)
Supply voltage range	195.5 V AC ... 253 V AC

General

Mechanical service life	15x 10 ⁶ cycles
Operating mode	100% operating factor
Mounting position	any
Assembly instructions	on standard DIN rail NS 35 in accordance with EN 60715
Electromagnetic compatibility	Conformance with EMC Directive 2014/30/EU
Housing insulation material	Polyamide PA 6.6, self-extinguishing
Color	gray

Connection data

Connection method	Push-in connection
Stripping length	8 mm
Conductor cross section solid	0.14 mm ² ... 2.5 mm ²
Conductor cross section flexible	0.14 mm ² ... 2.5 mm ²
Conductor cross section AWG	26 ... 14

Standards and Regulations

Electromagnetic compatibility	Conformance with EMC Directive 2014/30/EU
Noise emission	EN 61000-6-3
Noise immunity	EN 61000-6-2
Standards/regulations	IEC 60947-5-1
Rated surge voltage	4 kV
Pollution degree	2
Overvoltage category	III

Monitoring relay - EMD-BL-PTC-PT - 2906253

Technical data

Standards and Regulations

Low Voltage Directive	Conformance with Low Voltage Directive 2006/95/EC (valid until 2016-04-19) / 2014/35/EU (valid from 2016-04-20)
-----------------------	---

Environmental Product Compliance

China RoHS	Environmentally friendly use period: unlimited = EFUP-e
	No hazardous substances above threshold values

Drawings

Block diagram

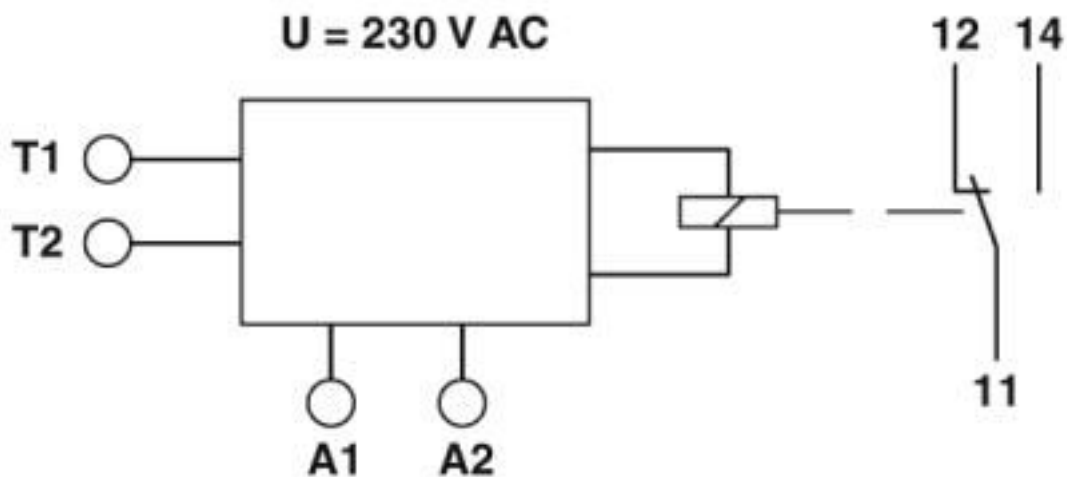

Classifications

eCl@ss

eCl@ss 10.0.1	27371810
eCl@ss 5.0	27371800
eCl@ss 5.1	27371800
eCl@ss 6.0	27371800
eCl@ss 7.0	27371810
eCl@ss 8.0	27371810
eCl@ss 9.0	27371810

ETIM

ETIM 2.0	EC001446
ETIM 3.0	EC001446
ETIM 4.0	EC001446
ETIM 5.0	EC002568
ETIM 6.0	EC001446
ETIM 7.0	EC001446

Monitoring relay - EMD-BL-PTC-PT - 2906253

Approvals

Approvals

Approvals

EAC / EAC

Ex Approvals

Approval details

EAC		TR_TS_D_00573_c
-----	---	-----------------

EAC		RU*C- DE.*08.B.00010
-----	--	-------------------------

Phoenix Contact 2020 © - all rights reserved
<http://www.phoenixcontact.com>

PHOENIX CONTACT GmbH & Co. KG
Flachsmarktstr. 8
32825 Blomberg
Germany
Tel. +49 5235 300
Fax +49 5235 3 41200
<http://www.phoenixcontact.com>

Mouser Electronics

Authorized Distributor

Click to View Pricing, Inventory, Delivery & Lifecycle Information:

[Phoenix Contact:](#)

[2906253](#)