

# Power supply unit - TRIO-PS/600DC/24DC/20 - 2866530

Please be informed that the data shown in this PDF Document is generated from our Online Catalog. Please find the complete data in the user's documentation. Our General Terms of Use for Downloads are valid (<http://phoenixcontact.com/download>)



DIN rail power supply unit, primary-switched, 1-phase, input: 600 V DC, output: 24 V DC/20 A

## Product Description

TRIO POWER is the power supply unit for the DIN rail with basic functionality at the highest level. TRIO POWER, 600 V DC, 24 V DC is ideally suited for connection to 600 V DC intermediate circuits of frequency inverters: In the event of a line supply failure, 24 V loads are supplied using the kinetic energy of the motor.

## Your advantages

- Compact buffer solution
- Fast tripping of standard circuit breakers
- Preventive function monitoring
- Reliable starting of difficult loads and easy system extension



## Key Commercial Data

Packing unit	1 pc
GTIN	 4 046356 556163
GTIN	4046356556163

## Technical data

### Dimensions

Width	115 mm
Height	130 mm
Depth	152.5 mm
Installation distance right/left	0 mm / 0 mm
Installation distance top/bottom	50 mm / 50 mm

### Ambient conditions

Degree of protection	IP20
Ambient temperature (operation)	-25 °C ... 70 °C (> 55° C derating : 2.5%/K)
Ambient temperature (storage/transport)	-40 °C ... 85 °C

# Power supply unit - TRIO-PS/600DC/24DC/20 - 2866530

## Technical data

### Ambient conditions

Max. permissible relative humidity (operation)	≤ 95 % (at 25 °C, non-condensing)
Climatic class	3K3 (in acc. with EN 60721)
Degree of pollution	2

### Input data

Nominal input voltage range	600 V DC
Input voltage range	450 V DC ... 840 V DC (Dielectric strength up to 900 V DC)
Frequency range DC	0 Hz
Discharge current to PE	< 3.5 mA
Current consumption	0.9 A (600 V DC)
Nominal power consumption	527.3 VA
Inrush current	< 26 A
Mains buffering time	typ. 15 ms (600 V DC)
Recommended breaker for input protection	4 A ... 6 A (1000 V DC)
Power factor (cos phi)	1
Type of protection	Transient surge protection
Protective circuit/component	Varistor

### Output data

Nominal output voltage	24 V DC ±1 %
Setting range of the output voltage (U <sub>Set</sub> )	22.5 V DC ... 29.5 V DC (U <sub>IN</sub> > 475 V DC)
	22.5 V DC ... 28 V DC (U <sub>IN</sub> ≤ 475 V DC)
Nominal output current (I <sub>N</sub> )	20 A (-25 °C ... 55 °C)
Derating	55 °C ... 70 °C (2.5%/K)
Connection in parallel	Yes, for redundancy and increased capacity
Connection in series	yes
Feedback voltage resistance	35 V DC
Protection against overvoltage at the output (OVP)	< 35 V DC
Max. capacitive load	unlimited
Active current limitation	Approx. 25 A (for short-circuit)
Control deviation	< 1 % (change in load, static 10 % ... 90 %)
	< 2 % (change in load, dynamic 10 % ... 90 %)
	< 0.1 % (change in input voltage ±10 %)
Residual ripple	< 40 mV <sub>PP</sub>
Output power	480 W
Typical response time	< 1 s
Peak switching voltages nominal load	< 10 mV <sub>PP</sub>
Maximum power dissipation in no-load condition	3.8 W
Power loss nominal load max.	45 W

### General

Net weight	2 kg
------------	------

# Power supply unit - TRIO-PS/600DC/24DC/20 - 2866530

## Technical data

### General

Efficiency	> 91 % (With 600 V DC and nominal values)
	> 701000 h (40 °C)
Insulation voltage input/output	4 kV AC (type test)
	2 kV AC (routine test)
Insulation voltage input / PE	2 kV AC (type test)
	2 kV AC (routine test)
Insulation voltage output / PE	500 V DC (routine test)
Degree of protection	IP20
Protection class	I (with PE connection)
Mounting position	horizontal DIN rail NS 35, EN 60715
Assembly instructions	alignable: horizontally 0 mm, vertically 50 mm

### Connection data, input

Connection method	Screw connection
Conductor cross section solid min.	0.2 mm <sup>2</sup>
Conductor cross section solid max.	2.5 mm <sup>2</sup>
Conductor cross section flexible min.	0.2 mm <sup>2</sup>
Conductor cross section flexible max.	2.5 mm <sup>2</sup>
Conductor cross section AWG min.	24
Conductor cross section AWG max.	14
Stripping length	9 mm
Screw thread	M2,5

### Connection data, output

Connection method	Screw connection
Conductor cross section solid min.	0.5 mm <sup>2</sup>
Conductor cross section solid max.	6 mm <sup>2</sup>
Conductor cross section flexible min.	0.5 mm <sup>2</sup>
Conductor cross section flexible max.	4 mm <sup>2</sup>
Conductor cross section AWG min.	12
Conductor cross section AWG max.	10
Stripping length	14 mm
Screw thread	M3

### Standards

EMC requirements for noise immunity	EN 61000-6-1
	EN 61000-6-2
EMC requirements for noise emission	EN 61000-6-3
	EN 61000-6-4
Standard - Electrical safety	EN 60950-1/VDE 0805 (SELV)
Standard – Electronic equipment for use in electrical power installations and their assembly into electrical power installations	EN 50178/VDE 0160 (PELV)
Standard – Safety extra-low voltage	EN 60950-1 (SELV)

# Power supply unit - TRIO-PS/600DC/24DC/20 - 2866530

## Technical data

### Standards

	EN 60204 (PELV)
Standard - Safe isolation	DIN VDE 0100-410
Standard – Protection against shock currents, basic requirements for protective separation in electrical equipment	EN 50178
Standard – Limitation of mains harmonic currents	EN 61000-3-2
Rail applications	EN 50121-4

### Conformance/approvals

UL approvals	UL/C-UL listed UL 508
	UL/C-UL Recognized UL 60950-1

### EMC data

Electromagnetic compatibility	Conformance with EMC Directive 2014/30/EU
Low Voltage Directive	Conformance with Low Voltage Directive 2014/35/EC
Electrostatic discharge	EN 61000-4-2
Contact discharge	8 kV (Test Level 4)
Discharge in air	15 kV (Test Level 4)
Electromagnetic HF field	EN 61000-4-3
Frequency range	80 MHz ... 1 GHz
Test field strength	20 V/m
Frequency range	1 GHz ... 2 GHz
Test field strength	10 V/m
Frequency range	2 GHz ... 3 GHz
Test field strength	10 V/m
Comments	Criterion A
Fast transients (burst)	EN 61000-4-4
Input	4 kV (Test Level 4 - asymmetrical)
Output	2 kV (Test Level 4 - asymmetrical)
Comments	Criterion B
Surge voltage load (surge)	EN 61000-4-5
Input	2 kV (Test Level 2 - symmetrical)
	4 kV (Test Level 4 - asymmetrical)
Output	1 kV (Test Level 2 - symmetrical)
	2 kV (Test Level 2 - asymmetrical)
Comments	Criterion A
Conducted interference	EN 61000-4-6
Frequency range	10 kHz ... 15 kHz
Voltage	10 V (Test Level 3)
Comments	Criterion A
Voltage dips	EN 61000-4-11

### Environmental Product Compliance

China RoHS	Environmentally Friendly Use Period = 25;
------------	---

# Power supply unit - TRIO-PS/600DC/24DC/20 - 2866530

## Technical data

### Environmental Product Compliance

	For details about hazardous substances go to tab "Downloads", Category "Manufacturer's declaration"
--	---

## Drawings

Block diagram

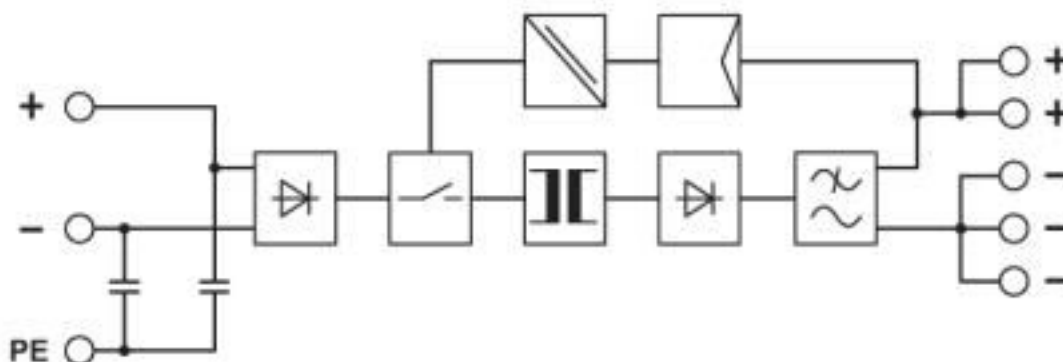

## Classifications

### eCl@ss

eCl@ss 10.0.1	27040701
eCl@ss 4.0	27040700
eCl@ss 4.1	27040700
eCl@ss 5.0	27049000
eCl@ss 5.1	27049000
eCl@ss 6.0	27049000
eCl@ss 7.0	27049002
eCl@ss 8.0	27049002
eCl@ss 9.0	27040701

### ETIM

ETIM 3.0	EC001039
ETIM 4.0	EC000599
ETIM 5.0	EC002540
ETIM 6.0	EC002540
ETIM 7.0	EC002540

### UNSPSC

UNSPSC 6.01	30211502
UNSPSC 7.0901	39121004
UNSPSC 11	39121004
UNSPSC 12.01	39121004

# Power supply unit - TRIO-PS/600DC/24DC/20 - 2866530

## Classifications

### UNSPSC

UNSPSC 13.2	39121004
UNSPSC 18.0	39121004
UNSPSC 19.0	39121004
UNSPSC 20.0	39121004
UNSPSC 21.0	39121004

## Approvals

### Approvals

#### Approvals

UL Listed / UL Recognized / cUL Recognized / cUL Listed / EAC / EAC / cULus Recognized / cULus Listed

#### Ex Approvals

### Approval details

UL Listed		<a href="http://database.ul.com/cgi-bin/XYV/template/LISEXT/1FRAME/index.htm">http://database.ul.com/cgi-bin/XYV/template/LISEXT/1FRAME/index.htm</a>	FILE E 123528
-----------	--	---	---------------

UL Recognized		<a href="http://database.ul.com/cgi-bin/XYV/template/LISEXT/1FRAME/index.htm">http://database.ul.com/cgi-bin/XYV/template/LISEXT/1FRAME/index.htm</a>	FILE E 211944
---------------	--	---	---------------

cUL Recognized		<a href="http://database.ul.com/cgi-bin/XYV/template/LISEXT/1FRAME/index.htm">http://database.ul.com/cgi-bin/XYV/template/LISEXT/1FRAME/index.htm</a>	FILE E 211944
----------------	--	---	---------------

cUL Listed		<a href="http://database.ul.com/cgi-bin/XYV/template/LISEXT/1FRAME/index.htm">http://database.ul.com/cgi-bin/XYV/template/LISEXT/1FRAME/index.htm</a>	FILE E 123528
------------	--	---	---------------

EAC		EAC-Zulassung
-----	--	---------------

EAC		RU*DE*08.B.01873/19
-----	--	---------------------

# Power supply unit - TRIO-PS/600DC/24DC/20 - 2866530

## Approvals

cULus Recognized



cULus Listed



## Accessories

### Accessories

#### Assembly adapter

Assembly adapters - UWA 182/52 - 2938235



Universal wall adapter for securely mounting the device in the event of strong vibrations. The device is screwed directly onto the mounting surface. The universal wall adapter is attached on the top/bottom.

#### Device protection

Type 3 surge protection device - PLT-SEC-T3-24-FM-UT - 2907916



Type 3 surge protection, consisting of protective plug and base element, with integrated status indicator and remote signaling for single-phase power supply networks. Nominal voltage 24 V AC/DC.

#### Mounting rail adapter

DIN rail adapter - UTA 107 - 2853983

Universal DIN rail adapter, for screwing on switchgear



Phoenix Contact 2020 © - all rights reserved  
<http://www.phoenixcontact.com>

PHOENIX CONTACT GmbH & Co. KG  
Flachsmarktstr. 8  
32825 Blomberg  
Germany  
Tel. +49 5235 300  
Fax +49 5235 3 41200  
<http://www.phoenixcontact.com>



# Mouser Electronics

Authorized Distributor

Click to View Pricing, Inventory, Delivery & Lifecycle Information:

[Phoenix Contact:](#)

[2866530](#)