

Distributed I/O device - AXL E IOL AO1 U M12 R - 2700278

Please be informed that the data shown in this PDF Document is generated from our Online Catalog. Please find the complete data in the user's documentation. Our General Terms of Use for Downloads are valid (<http://phoenixcontact.com/download>)



Axioline E-IO-Link/analog converter for connecting an analog actuator, 0 V ... 10 V, M12 fast connection technology, angled version

Your advantages

- Angled version
- 1 IO-Link interface
- 1 analog output
- Connection of the actuator in 3-wire technology
- Voltage range: 0 V ... 10 V
- IO-Link and actuator connections via M12 connectors
- Functional ground connection for local connection to functional ground
- Supply of the module electronics and the actuator via the IO-Link interface of the IO-Link master
- Diagnostic indicator
-



© IO-Link

Key Commercial Data

Packing unit	1 pc
GTIN	 4 046356 782593
GTIN	4046356782593

Technical data

Note

Utilization restriction	EMC: class A product, see manufacturer's declaration in the download area
-------------------------	---

Dimensions

Width	16.6 mm
Height	42 mm
Depth	66.5 mm

Distributed I/O device - AXL E IOL AO1 U M12 R - 2700278

Technical data

Ambient conditions

Ambient temperature (operation)	-25 °C ... 60 °C
Ambient temperature (storage/transport)	-25 °C ... 85 °C
Permissible humidity (operation)	5 % ... 95 %
Permissible humidity (storage/transport)	5 % ... 95 %
Air pressure (operation)	70 kPa ... 106 kPa (up to 3000 m above sea level)
Air pressure (storage/transport)	70 kPa ... 106 kPa (up to 3000 m above sea level)
Degree of protection	IP65/IP67

General

Net weight	34 g
Degree of pollution	2
Diagnostics messages	Short circuit Message in the diagnostic code (in the IB IL format)
	Configuration invalid Message in the diagnostic code (in the IB IL format)
	Module faulty Message in the diagnostic code (in the IB IL format)

Standards and Regulations

Mechanical tests	Vibration resistance in acc. with EN 60068-2-6/IEC 60068-2-6 Operation: 2g
	Vibration resistance in acc. with EN 60068-2-6/IEC 60068-2-6 Storage/ transport: 5g
	Shock in acc. with EN 60068-2-27/IEC 60068-2-27 Operation: 30g, 11 ms, three shocks in each space direction
	Shock in acc. with EN 60068-2-27/IEC 60068-2-27 Storage/ transport: 50g, 11 ms, three shocks in each space direction
	Continuous shock according to EN 60068-2-27/IEC 60068-2-27 10g, 16 ms, 1000 shocks, in all space directions
Protection class	III (IEC 61140, EN 61140, VDE 0140-1)

Environmental Product Compliance

REACH SVHC	Lead 7439-92-1
------------	----------------

Drawings

Distributed I/O device - AXL E IOL AO1 U M12 R - 2700278

Connection diagram

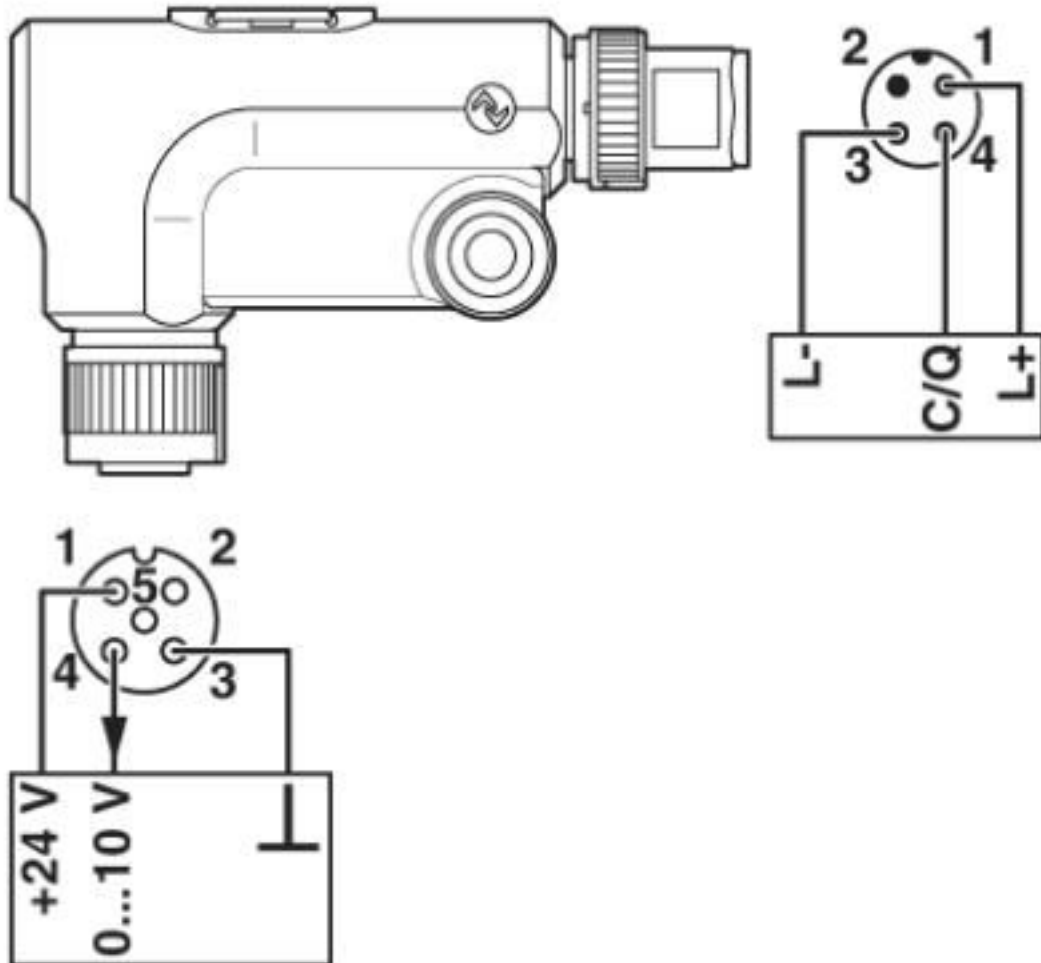

Block diagram

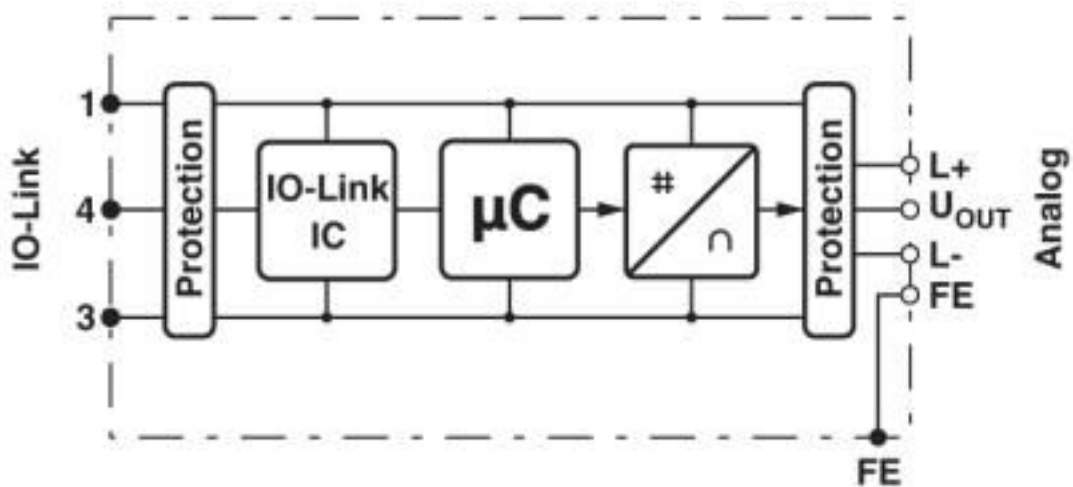

Distributed I/O device - AXL E IOL AO1 U M12 R - 2700278

Dimensional drawing

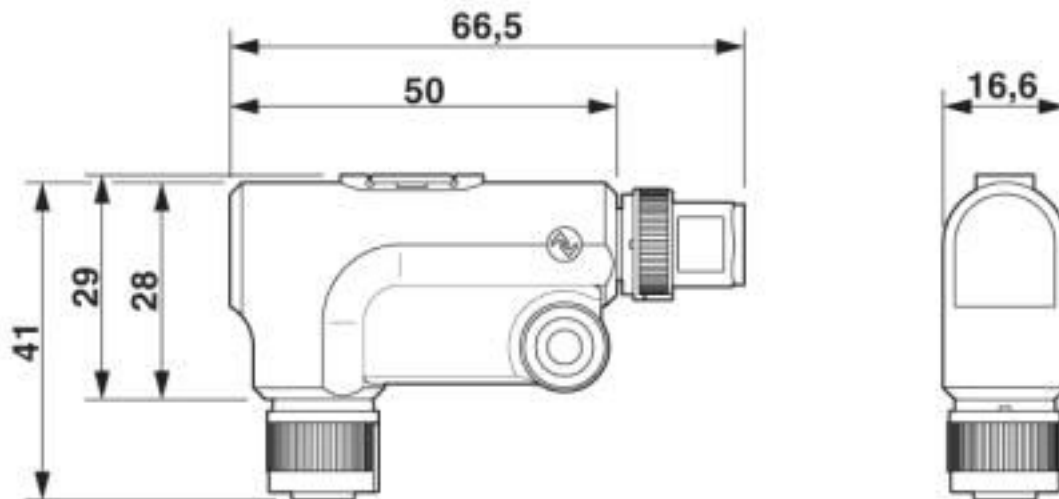

Classifications

eCl@ss

eCl@ss 10.0.1	27242601
eCl@ss 4.0	27250200
eCl@ss 4.1	27250200
eCl@ss 5.0	27250200
eCl@ss 5.1	27242600
eCl@ss 6.0	27242600
eCl@ss 7.0	27242601
eCl@ss 8.0	27242601
eCl@ss 9.0	27242601

ETIM

ETIM 3.0	EC000313
ETIM 4.0	EC001596
ETIM 5.0	EC001596
ETIM 6.0	EC001596
ETIM 7.0	EC001596

UNSPSC

UNSPSC 6.01	43172015
UNSPSC 7.0901	43201404
UNSPSC 11	43172015
UNSPSC 12.01	55101516
UNSPSC 13.2	32151602
UNSPSC 18.0	32151602
UNSPSC 19.0	32151602

Distributed I/O device - AXL E IOL AO1 U M12 R - 2700278

Classifications

UNSPSC

UNSPSC 20.0	32151602
UNSPSC 21.0	32151602

Approvals

Approvals

Approvals

UL Listed / cUL Listed / cULus Listed

Ex Approvals

Approval details

UL Listed		http://database.ul.com/cgi-bin/XYV/template/LISEXT/1FRAME/index.htm	FILE E 140324
-----------	--	---	---------------

cUL Listed		http://database.ul.com/cgi-bin/XYV/template/LISEXT/1FRAME/index.htm	FILE E 140324
------------	--	---	---------------

cULus Listed			
--------------	--	--	--

Phoenix Contact 2020 © - all rights reserved
<http://www.phoenixcontact.com>

PHOENIX CONTACT GmbH & Co. KG
Flachsmarktstr. 8
32825 Blomberg
Germany
Tel. +49 5235 300
Fax +49 5235 3 41200
<http://www.phoenixcontact.com>

Mouser Electronics

Authorized Distributor

Click to View Pricing, Inventory, Delivery & Lifecycle Information:

[Phoenix Contact:](#)

[2700278](#)