

Front adapters - FLKM 14-PA-INLINE/OUT16 - 2302764

Please be informed that the data shown in this PDF Document is generated from our Online Catalog. Please find the complete data in the user's documentation. Our General Terms of Use for Downloads are valid (<http://phoenixcontact.com/download>)



VARIOFACE front adapter for Inline modules, for transferring 16 (2 x 8) digital output signals.

RoHS

Key Commercial Data

Packing unit	1 pc
GTIN	 4 017918 929480
GTIN	4017918929480

Technical data

Dimensions

Width	44 mm
Height	27 mm
Depth	66.5 mm

Ambient conditions

Ambient temperature (operation)	-20 °C ... 50 °C
Ambient temperature (storage/transport)	-20 °C ... 70 °C
Degree of protection	IP20

General

Max. permissible operating voltage	60 V DC
Max. permissible current	1 A (per path)
Mounting position	any

Standards and Regulations

Standards/regulations	IEC 60664
	DIN EN 50178
Rated insulation voltage	63 V
Rated surge voltage	0.6 kV

Front adapters - FLKM 14-PA-INLINE/OUT16 - 2302764

Technical data

Standards and Regulations

Insulation	Functional insulation
Pollution degree	2
Overvoltage category	II

Connection data

Connection name	Controller level
Channels which can be connected	32

Connection data 2

Connection name	Field level
Connection method	IDC/FLK pin strip
Number of connections	2
Number of positions	14
Pitch	2.54 mm

Supported controller

Controller	PHOENIX CONTACT Inline
- suitable I/O card	IB IL 24 DO 16-PAC
	ILB ... 24 DO16
	ILB ... 24 DO32
	ILB ... 24 DI16 DO16

Environmental Product Compliance

REACH SVHC	Lead 7439-92-1
China RoHS	Environmentally Friendly Use Period = 50 years
	For details about hazardous substances go to tab "Downloads", Category "Manufacturer's declaration"

Drawings

Front adapters - FLKM 14-PA-INLINE/OUT16 - 2302764

Circuit diagram

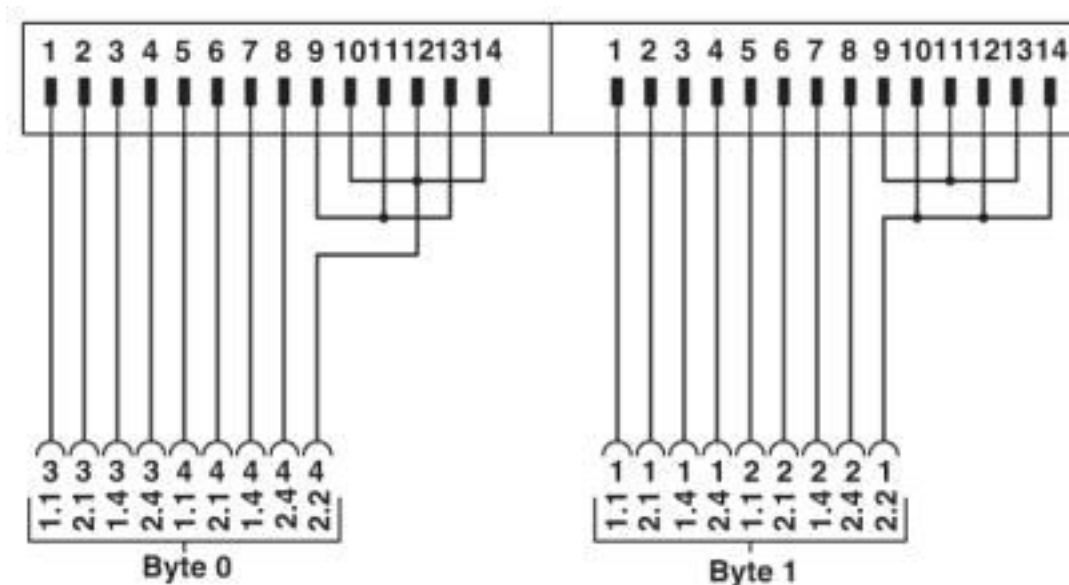

Connection scheme: FLKM 14-PA-INLINE/OUT16

Classifications

eCl@ss

eCl@ss 10.0.1	27242292
eCl@ss 4.0	27250300
eCl@ss 4.1	27250300
eCl@ss 5.0	27250300
eCl@ss 5.1	27250300
eCl@ss 6.0	27249200
eCl@ss 7.0	27249290
eCl@ss 8.0	27249290
eCl@ss 9.0	27242292

ETIM

ETIM 4.0	EC002584
ETIM 5.0	EC002584
ETIM 6.0	EC002584
ETIM 7.0	EC002584

UNSPSC

UNSPSC 6.01	30211824
UNSPSC 7.0901	39121402
UNSPSC 11	39121402
UNSPSC 12.01	39121402
UNSPSC 13.2	32151601

Front adapters - FLKM 14-PA-INLINE/OUT16 - 2302764

Classifications

UNSPSC

UNSPSC 18.0	32151601
UNSPSC 19.0	32151601
UNSPSC 20.0	32151601
UNSPSC 21.0	32151601

Approvals

Approvals

Approvals

EAC

Ex Approvals

Approval details

EAC		RU C- DE.A*30.B.01742
-----	---	--------------------------

Phoenix Contact 2020 © - all rights reserved
<http://www.phoenixcontact.com>

PHOENIX CONTACT GmbH & Co. KG
Flachsmarktstr. 8
32825 Blomberg
Germany
Tel. +49 5235 300
Fax +49 5235 3 41200
<http://www.phoenixcontact.com>

Mouser Electronics

Authorized Distributor

Click to View Pricing, Inventory, Delivery & Lifecycle Information:

[Phoenix Contact:](#)

[2302764](#)