

Printed-circuit board connector - QC 0,5/ 6-ST-3,81 - 1897432

Please be informed that the data shown in this PDF Document is generated from our Online Catalog. Please find the complete data in the user's documentation. Our General Terms of Use for Downloads are valid (<http://phoenixcontact.com/download>)

PCB connector, nominal current: 6 A, rated voltage (III/2): 200 V, nominal cross section: 0.5 mm², number of positions: 6, pitch: 3.81 mm, connection method: Displacement connection, color: green, contact surface: Tin

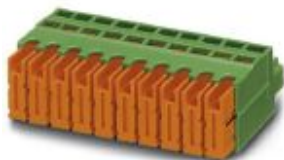

The figure shows a 10-position version of the product

Your advantages

- Connection without conductor pretreatment for huge time savings
- Quick and convenient testing using integrated test option

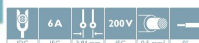

Key Commercial Data

Packing unit	50 pc
GTIN	 4 017918 164935
GTIN	4017918164935

Technical data

Item properties

Brief article description	Printed-circuit board connector
Plug-in system	MINI COMBICON
Type of contact	Female connector
Range of articles	QC 0,5/..-ST
Pitch	3.81 mm
Number of positions	6
Connection method	Displacement connection
Locking	without
Number of levels	1
Number of connections	6
Number of potentials	6

Electrical parameters

Printed-circuit board connector - QC 0,5/ 6-ST-3,81 - 1897432

Technical data

Electrical parameters

Nominal current	6 A
Nom. voltage	200 V
Rated voltage	200 V
Rated voltage (III/2)	200 V
Rated voltage (II/2)	400 V
Rated surge voltage (III/3)	4 kV
Rated surge voltage (III/2)	4 kV
Rated surge voltage (II/2)	4 kV

Connection capacity

Connection method	Displacement connection
pluggable	Yes
Conductor cross section flexible	0.34 mm ² ... 0.5 mm ²
Conductor cross section AWG / kcmil	22 ... 20

Material data - contact

Note	WEEE/RoHS-compliant, free of whiskers according to IEC 60068-2-82/ JEDEC JESD 201
Contact material	Cu alloy
Surface characteristics	hot-dip tin-plated
Metal surface terminal point (top layer)	Tin (5 - 7 µm Sn)
Metal surface contact area (top layer)	Tin (5 - 7 µm Sn)

Material data - housing

Housing color	green (6021)
Insulating material	PA
Insulating material group	I
CTI according to IEC 60112	600
Flammability rating according to UL 94	V0
Glow wire flammability index GWFI according to EN 60695-2-12	850
Glow wire ignition temperature GWIT according to EN 60695-2-13	775
Temperature for the ball pressure test according to EN 60695-10-2	125 °C

Dimensions for the product

Length [l]	26.8 mm
Width [w]	23.65 mm
Height [h]	12.9 mm
Pitch	3.81 mm
Height (without solder pin)	12.9 mm

Packaging information

Type of packaging	packed in cardboard
Pieces per package	50
Denomination packing units	Pcs.

Printed-circuit board connector - QC 0,5/ 6-ST-3,81 - 1897432

Technical data

Environmental Product Compliance

China RoHS	Environmentally friendly use period: unlimited = EFUP-e
	No hazardous substances above threshold values

Drawings

Dimensional drawing

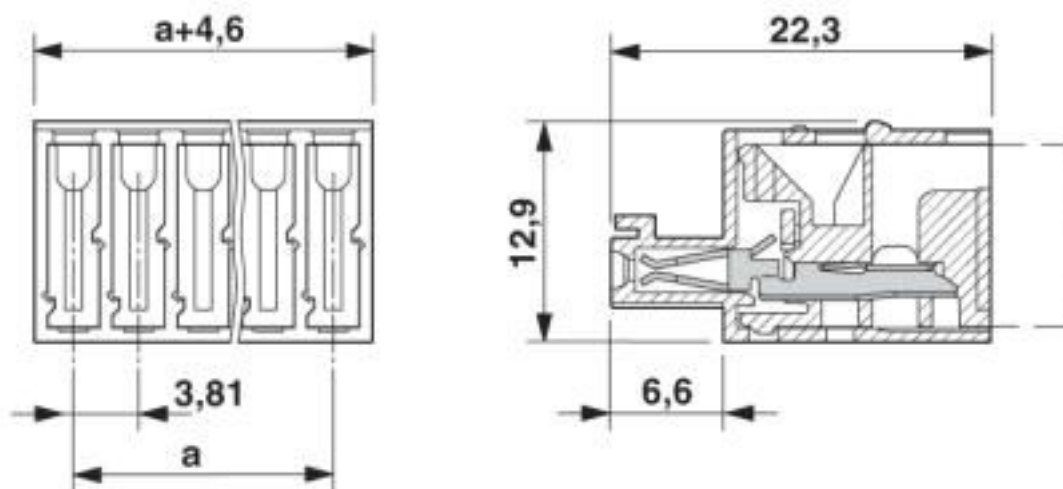

Classifications

eCl@ss

eCl@ss 10.0.1	27440309
eCl@ss 4.0	27260700
eCl@ss 4.1	27260700
eCl@ss 5.0	27260700
eCl@ss 5.1	27260700
eCl@ss 6.0	27260700
eCl@ss 7.0	27440309
eCl@ss 8.0	27440309
eCl@ss 9.0	27440309

ETIM

ETIM 3.0	EC001121
ETIM 4.0	EC002638
ETIM 5.0	EC002638
ETIM 6.0	EC002638
ETIM 7.0	EC002638

UNSPSC

UNSPSC 6.01	30211810
-------------	----------

Printed-circuit board connector - QC 0,5/ 6-ST-3,81 - 1897432

Classifications

UNSPSC

UNSPSC 7.0901	39121409
UNSPSC 11	39121409
UNSPSC 12.01	39121409
UNSPSC 13.2	39121409
UNSPSC 18.0	39121409
UNSPSC 19.0	39121409
UNSPSC 20.0	39121409
UNSPSC 21.0	39121409

Approvals

Approvals

Approvals

UL Recognized / cUL Recognized / IEC CB Scheme / VDE Gutachten mit Fertigungsüberwachung / EAC / cULus Recognized

Ex Approvals

Approval details

UL Recognized		http://database.ul.com/cgi-bin/XYV/template/LISEXT/1FRAME/index.htm	FILE E 60425
	B	C	
Nominal voltage UN	300 V	300 V	
Nominal current IN	6 A	6 A	
mm ² /AWG/kcmil	24-20	24-20	

cUL Recognized		http://database.ul.com/cgi-bin/XYV/template/LISEXT/1FRAME/index.htm	FILE E 60425
	B	C	
Nominal voltage UN	300 V	300 V	
Nominal current IN	6 A	6 A	
mm ² /AWG/kcmil	24-20	24-20	

Printed-circuit board connector - QC 0,5/ 6-ST-3,81 - 1897432

Approvals

IECEE CB Scheme		http://www.iecee.org/	DE1-60987-B1B2
Nominal voltage UN	320 V		
Nominal current IN	5 A		
mm ² /AWG/kcmil	0.34-.5		

VDE Gutachten mit Fertigungsüberwachung		http://www2.vde.com/de/Institut/Online-Service/VDE-gepruefteProdukte/Seiten/Online-Suche.aspx	40011723
Nominal voltage UN	320 V		
Nominal current IN	5 A		
mm ² /AWG/kcmil	0.34-.5		

EAC			B.01687
-----	--	--	---------

cULus Recognized			
------------------	--	--	--

Accessories

Accessories

Labeled terminal marker

Marker card - SK 3,81/2,8:FORTL.ZAHLEN - 0804109



Marker card, Card, white, labeled, horizontal: consecutive numbers 1 ... 10, 11 ... 20, etc. up to 91 ... (99)100, mounting type: adhesive, for terminal block width: 3.81 mm, lettering field size: 3.81 x 2.8 mm

Screwdriver tools

Printed-circuit board connector - QC 0,5/ 6-ST-3,81 - 1897432

Accessories

Screwdriver - SZS 0,4X2,0 - 1205202



Micro screwdriver, bladed, size: 0.4 x 2.0 x 60 mm, 2-component grip, with non-slip grip and twist cap

Additional products

Feed-through header - MCV 1,5/ 6-G-3,81 P14 THR - 1707049



PCB headers, nominal current: 8 A, rated voltage (III/2): 160 V, nominal cross section: 1.5 mm², number of positions: 6, pitch: 3.81 mm, color: black, contact surface: Tin, mounting: THR soldering, pin layout: Linear pinning, solder pin [P]: 1.4 mm, User information and design recommendations for through hole reflow technology can be found under: Downloads

Feed-through header - MCV 1,5/ 6-G-3,81 P26 THR - 1707463



PCB headers, nominal current: 8 A, rated voltage (III/2): 160 V, nominal cross section: 1.5 mm², number of positions: 6, pitch: 3.81 mm, color: black, contact surface: Tin, mounting: THR soldering, pin layout: Linear pinning, solder pin [P]: 2.6 mm, User information and design recommendations for through hole reflow technology can be found under: Downloads

Feed-through header - MCV 1,5/ 6-G-3,81 P26 THRR56 - 1712911



PCB headers, nominal current: 8 A, rated voltage (III/2): 160 V, nominal cross section: 1.5 mm², number of positions: 6, pitch: 3.81 mm, color: black, contact surface: Tin, mounting: THR soldering, pin layout: Linear pinning, solder pin [P]: 2.6 mm, User information and design recommendations for through hole reflow technology can be found under: Downloads

Printed-circuit board connector - MC 1,5/ 6-G-3,81 - 1803316



PCB headers, nominal current: 8 A, rated voltage (III/2): 160 V, nominal cross section: 1.5 mm², number of positions: 6, pitch: 3.81 mm, color: green, contact surface: Tin, mounting: Wave soldering, pin layout: Linear pinning, solder pin [P]: 3.4 mm

Printed-circuit board connector - QC 0,5/ 6-ST-3,81 - 1897432

Accessories

Printed-circuit board connector - MCV 1,5/ 6-G-3,81 - 1803468



PCB headers, nominal current: 8 A, rated voltage (III/2): 160 V, nominal cross section: 1.5 mm², number of positions: 6, pitch: 3.81 mm, color: green, contact surface: Tin, mounting: Wave soldering, pin layout: Linear pinning, solder pin [P]: 3.4 mm

Printed-circuit board connector - SMC 1,5/ 6-G-3,81 - 1827318



PCB headers, nominal current: 8 A, rated voltage (III/2): 160 V, nominal cross section: 1.5 mm², number of positions: 6, pitch: 3.81 mm, color: green, contact surface: Tin, mounting: Wave soldering, pin layout: Linear pinning, solder pin [P]: 3.4 mm

Feed-through header - MCD 1,5/ 6-G-3,81 - 1829992



PCB headers, nominal current: 8 A, rated voltage (III/2): 160 V, nominal cross section: 1.5 mm², number of positions: 6, pitch: 3.81 mm, color: green, contact surface: Tin, mounting: Wave soldering, pin layout: Linear pinning, solder pin [P]: 3.5 mm, In combination with MCV plug components, both an MCVW and an MCVR plug must be used.

Feed-through header - MCDV 1,5/ 6-G-3,81 - 1830444



PCB headers, nominal current: 8 A, rated voltage (III/2): 160 V, nominal cross section: 1.5 mm², number of positions: 6, pitch: 3.81 mm, color: green, contact surface: Tin, mounting: Wave soldering, pin layout: Linear pinning, solder pin [P]: 3.4 mm, In combination with MCV plug components, both an MCVW and an MCVR plug must be used.

Feed-through header - MCVDU 1,5/ 6-G-3,81 - 1837476



PCB headers, nominal current: 8 A, rated voltage (III/2): 160 V, nominal cross section: 1.5 mm², number of positions: 6, pitch: 3.81 mm, color: green, contact surface: Tin, mounting: Wave soldering, pin layout: Linear pinning, solder pin [P]: 2.5 mm

Printed-circuit board connector - QC 0,5/ 6-ST-3,81 - 1897432

Accessories

Printed-circuit board connector - MCD 1,5/ 6-G1-3,81 - 1843114



PCB headers, nominal current: 8 A, rated voltage (III/2): 160 V, nominal cross section: 1.5 mm², number of positions: 6, pitch: 3.81 mm, color: green, contact surface: Tin, mounting: Wave soldering, pin layout: Linear pinning, solder pin [P]: 3.5 mm, In combination with MCV plug components, both an MCVW and an MCVR plug must be used.

Feed-through header - MCDV 1,5/ 6-G1-3,81 - 1847767



PCB headers, nominal current: 8 A, rated voltage (III/2): 160 V, nominal cross section: 1.5 mm², number of positions: 6, pitch: 3.81 mm, color: green, contact surface: Tin, mounting: Wave soldering, pin layout: Linear pinning, solder pin [P]: 3.4 mm, In combination with MCV plug components, both an MCVW and an MCVR plug must be used.

Feed-through header - EMCV 1,5/ 6-G-3,81 - 1860689



PCB headers, nominal current: 8 A, rated voltage (III/2): 160 V, nominal cross section: 1.5 mm², number of positions: 6, pitch: 3.81 mm, color: green, contact surface: Tin, mounting: Press-in technology, pin layout: Linear pinning, solder pin [P]: 3.8 mm

Feed-through header - MCO 1,5/ 6-GR-3,81 - 1861688



PCB headers, nominal current: 8 A, rated voltage (III/2): 160 V, nominal cross section: 1.5 mm², number of positions: 6, pitch: 3.81 mm, color: green, contact surface: Tin, mounting: Wave soldering, pin layout: Linear pinning, solder pin [P]: 3 mm

Feed-through header - MCO 1,5/ 6-GL-3,81 - 1861769



PCB headers, nominal current: 8 A, rated voltage (III/2): 160 V, nominal cross section: 1.5 mm², number of positions: 6, pitch: 3.81 mm, color: green, contact surface: Tin, mounting: Wave soldering, pin layout: Linear pinning, solder pin [P]: 3 mm

Printed-circuit board connector - QC 0,5/ 6-ST-3,81 - 1897432

Accessories

Feed-through header - EMC 1,5/ 6-G-3,81 - 1897843

PCB headers, nominal current: 8 A, rated voltage (III/2): 160 V, nominal cross section: 1.5 mm², number of positions: 6, pitch: 3.81 mm, color: green, contact surface: Tin, mounting: Press-in technology, pin layout: Linear pinning, solder pin [P]: 3.5 mm



Feed-through header - MC 1,5/ 6-G-3,81 THT - 1908800

PCB headers, number of positions: 6, pitch: 3.81 mm, color: black, contact surface: Tin, pin layout: Linear pinning, solder pin [P]: 3.4 mm, User information and design recommendations for through hole reflow technology can be found under: Downloads



Feed-through header - MC 1,5/ 6-G-3,81 THT-R56 - 1943797

PCB headers, number of positions: 6, pitch: 3.81 mm, color: black, contact surface: Tin, pin layout: Linear pinning, User information and design recommendations for through hole reflow technology can be found under: Downloads



Feed-through header - MCD 1,5/ 6-G1-3,81 HT BK - 1958368

PCB headers, nominal current: 8 A, rated voltage (III/2): 160 V, nominal cross section: 1.5 mm², number of positions: 6, pitch: 3.81 mm, color: black, contact surface: Tin, mounting: THR soldering, pin layout: Linear pinning, Standard component made of highly temperature resistant plastic; suitable for reflow process. User information and design recommendations on Through Hole Reflow Technology can be found at: "Downloads".



Mouser Electronics

Authorized Distributor

Click to View Pricing, Inventory, Delivery & Lifecycle Information:

[Phoenix Contact:](#)

[1897432](#)