

D-SUB pressure nut - VS-M16 (5-9) - 1688447

Please be informed that the data shown in this PDF Document is generated from our Online Catalog. Please find the complete data in the user's documentation. Our General Terms of Use for Downloads are valid (<http://phoenixcontact.com/download>)



D-SUB cap nut with line seal, for sleeve housing VS-09-..., conductor diameter of 5 mm ... 9 mm

Your advantages

- Including seal
- Easy mounting



Key Commercial Data

Packing unit	5 pc
Minimum order quantity	5 pc
GTIN	 4 017918 818364
GTIN	4017918818364

Technical data

Mechanical characteristics

Minimum external conductor diameter	5 mm
Maximum external conductor diameter	9 mm
Weight	2.69 g
Flammability rating according to UL 94	V0

Ambient conditions

Ambient temperature (operation)	-40 °C ... 80 °C
Ambient temperature (assembly)	-20 °C ... 80 °C

Material data

Housing material	PA
------------------	----

Standards and Regulations

Flammability rating according to UL 94	V0
--	----

D-SUB pressure nut - VS-M16 (5-9) - 1688447

Drawings

Dimensional drawing

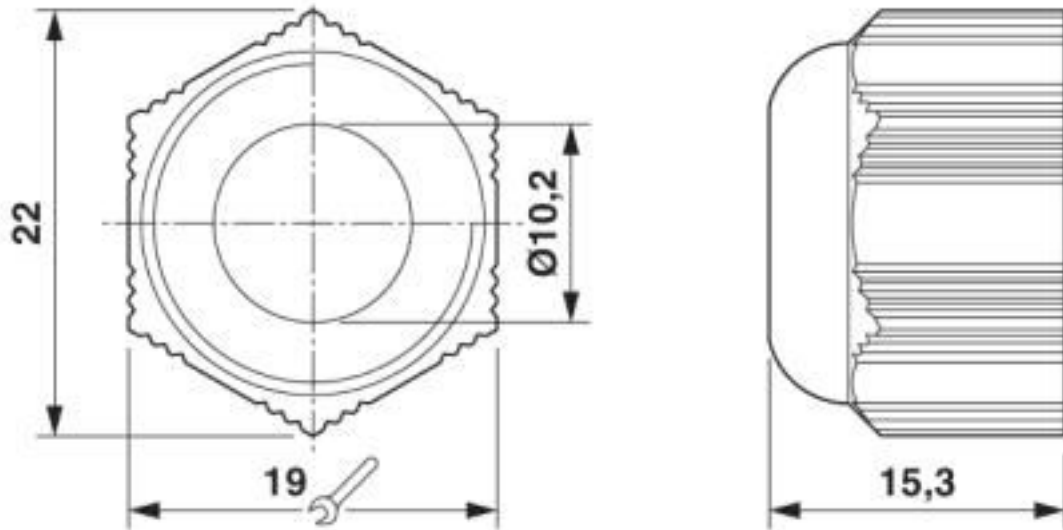

Seal

Dimensional drawing

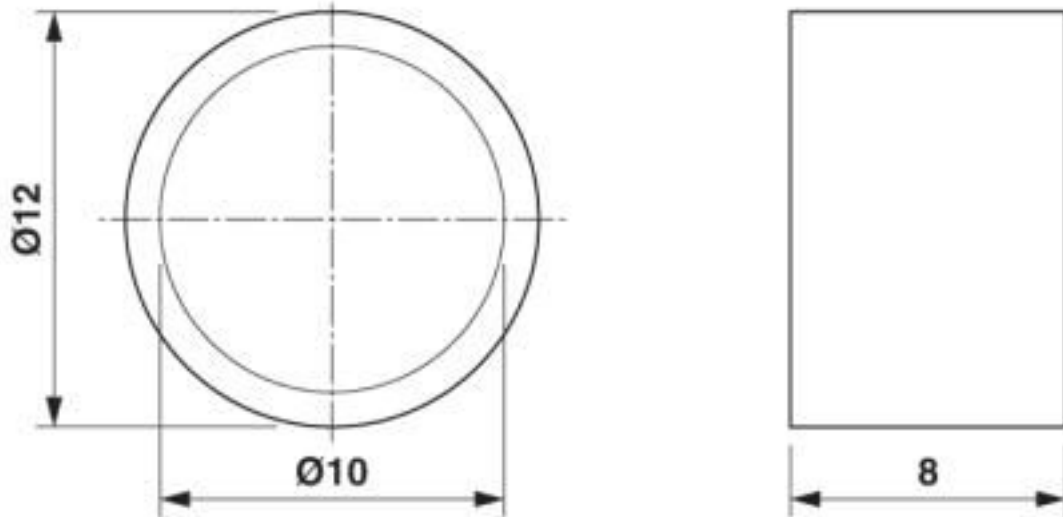

Screw pressure nut

Classifications

eCl@ss

eCl@ss 10.0.1	27144420
eCl@ss 4.0	27141200
eCl@ss 4.1	27141200

D-SUB pressure nut - VS-M16 (5-9) - 1688447

Classifications

eCl@ss

eCl@ss 5.0	27149100
eCl@ss 5.1	27149100
eCl@ss 6.0	27149100
eCl@ss 7.0	27069215
eCl@ss 8.0	27069215
eCl@ss 9.0	27144420

ETIM

ETIM 2.0	EC000441
ETIM 3.0	EC000441
ETIM 4.0	EC000441
ETIM 5.0	EC000814
ETIM 6.0	EC000814
ETIM 7.0	EC000814

UNSPSC

UNSPSC 6.01	30211923
UNSPSC 7.0901	39121522
UNSPSC 11	39121522
UNSPSC 12.01	39121522
UNSPSC 13.2	31161514
UNSPSC 18.0	31161514
UNSPSC 19.0	31161514
UNSPSC 20.0	31161514
UNSPSC 21.0	31161514

Approvals

Approvals

Approvals

EAC

Ex Approvals

Approval details

EAC		B.01742
-----	---	---------

D-SUB pressure nut - VS-M16 (5-9) - 1688447

Accessories

Accessories

Sleeve housings

D-SUB sleeve housings - VS-09-T-2M16 - 1688353



D-SUB sleeve housings, degree of protection: IP67, material: PA, cable outlet: Angled, size of housing: 1, color: gray

Phoenix Contact 2020 © - all rights reserved
<http://www.phoenixcontact.com>

PHOENIX CONTACT GmbH & Co. KG
Flachsmarktstr. 8
32825 Blomberg
Germany
Tel. +49 5235 300
Fax +49 5235 3 41200
<http://www.phoenixcontact.com>

Mouser Electronics

Authorized Distributor

Click to View Pricing, Inventory, Delivery & Lifecycle Information:

[Phoenix Contact:](#)

[1688447](#)