

# Coaxial contact - HC-M-04-BU-KOAX-75 - 1686258

Please be informed that the data shown in this PDF Document is generated from our Online Catalog. Please find the complete data in the user's documentation. Our General Terms of Use for Downloads are valid (<http://phoenixcontact.com/download>)



Coaxial contact, contact diameter: 4.8 mm, turned, Socket, contact material: Copper alloy, contact surface: gold-plated, connection cross section: 0.14 mm<sup>2</sup> ... 2.5 mm<sup>2</sup> AWG 26 ... 14, Wave impedance: 75 Ω



## Key Commercial Data

Packing unit	10 pc
GTIN	
GTIN	4017918174132

## Technical data

### Electrical characteristics

Rated voltage (III/3)	50 V AC
Rated current	1.5 A
Wave impedance	75 Ω

### Ambient conditions

Ambient temperature (operation)	-40 °C ... 125 °C
---------------------------------	-------------------

### Mechanical characteristics

Conductor cross section	0.14 mm <sup>2</sup> ... 2.5 mm <sup>2</sup>
Connection cross section AWG	26 ... 14
Stripping length of the individual wire	2 mm
Contact diameter	4.8 mm
Insertion/withdrawal cycles	≥ 500

### General

Note	Cables that can be used for the coaxial contact: RG179B/U, RG187A/U
	Coaxial contact for module HC-M-04-KT-M
Type	Individual male contact
Series	HC-M-04-KOAX

## Coaxial contact - HC-M-04-BU-KOAX-75 - 1686258

### Technical data

#### General

Connection method	Soldering and crimp connection (Solder connection (wire) / crimp connection (braided shield))
Connection in acc. with standard	IEC / EN
Contact type	turned

#### Material data

Contact material	Copper alloy
Contact surface material	gold-plated

#### Standards and Regulations

Connection in acc. with standard	UL
----------------------------------	----

#### Environmental Product Compliance

China RoHS	Environmentally friendly use period: unlimited = EFUP-e
	No hazardous substances above threshold values

### Drawings

# Coaxial contact - HC-M-04-BU-KOAX-75 - 1686258

Schematic diagram

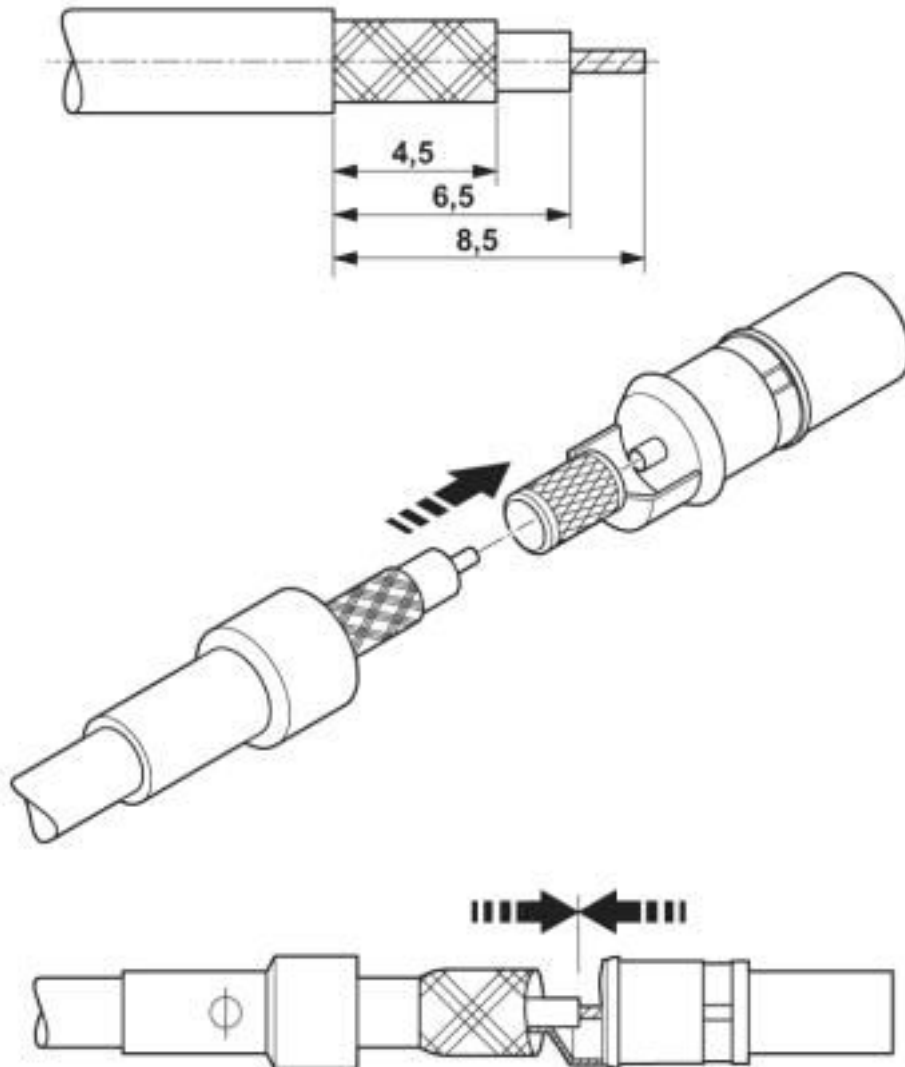

**Assembly instruction:**

RG cables 174/U; 188A/U; 316/U; 179B/U; 187A/U. Prepare the cable (see diagram) and slide the sleeve over the cable. Then solder the wire to the coaxial contact and lay the braided shield over the ridges of the contact. Slide the sleeve over the braided shield and crimp the shield/cable along the narrow contact collar.

## Classifications

eCl@ss

eCl@ss 10.0.1	27440204
eCl@ss 4.0	27140800
eCl@ss 4.1	27140800
eCl@ss 5.0	27143400
eCl@ss 5.1	27261200
eCl@ss 6.0	27261200
eCl@ss 7.0	27440204

# Coaxial contact - HC-M-04-BU-KOAX-75 - 1686258

## Classifications

### eCl@ss

eCl@ss 8.0	27440204
eCl@ss 9.0	27440204

### ETIM

ETIM 2.0	EC000796
ETIM 3.0	EC000796
ETIM 4.0	EC000796
ETIM 5.0	EC000796
ETIM 6.0	EC000796
ETIM 7.0	EC000796

### UNSPSC

UNSPSC 6.01	30211923
UNSPSC 7.0901	39121522
UNSPSC 11	39121522
UNSPSC 12.01	39121522
UNSPSC 13.2	39121522
UNSPSC 18.0	39121522
UNSPSC 19.0	39121522
UNSPSC 20.0	39121522
UNSPSC 21.0	39121522

## Approvals

### Approvals

---

#### Approvals

UL Recognized / EAC

---

#### Ex Approvals

---

### Approval details

UL Recognized		<a href="http://database.ul.com/cgi-bin/XYV/template/LISEXT/1FRAME/index.htm">http://database.ul.com/cgi-bin/XYV/template/LISEXT/1FRAME/index.htm</a>	FILE E 118976
Nominal voltage UN	600 V		

## Coaxial contact - HC-M-04-BU-KOAX-75 - 1686258

### Approvals

EAC



RU C-  
DE.AI30.B.01102

### Accessories

#### Accessories

#### Assembly tool

Contact removal tool - HC-M4-KOAX-EWZ - 1676747



Contact removal tool for coaxial contacts

### Crimping tool

Crimping pliers - CRIMPFOX-CX 4,52 - 1212094



Crimping pliers, for coaxial connectors, 3.25 mm, 4.52 mm, 1.69 mm, HEX crimp

### Additional products

Coaxial contact - HC-M-04-ST-KOAX-75 - 1686245



Coaxial contact, contact diameter: 4.8 mm, turned, Pin, contact material: Copper alloy, contact surface: gold-plated, connection cross section: 0.14 mm<sup>2</sup> ... 2.5 mm<sup>2</sup> AWG 26 ... 14, Wave impedance: 75 Ω

# Mouser Electronics

Authorized Distributor

Click to View Pricing, Inventory, Delivery & Lifecycle Information:

[Phoenix Contact:](#)

[1686258](#)