

D-SUB coaxial contact - VS-ST-KX-50-LP - 1655522

Please be informed that the data shown in this PDF Document is generated from our Online Catalog. Please find the complete data in the user's documentation. Our General Terms of Use for Downloads are valid (<http://phoenixcontact.com/download>)



Coaxial contact, for D-SUB combination inserts, for PCB assembly, pin, angled, gold-plated



Key Commercial Data

Packing unit	10 pc
GTIN	
GTIN	4046356029452

Technical data

Mechanical characteristics

Connection method	PCB mounting
Weight	4.08 g

Ambient conditions

Ambient temperature (operation)	-55 °C ... 135 °C
---------------------------------	-------------------

Material data

Contact surface material	Hard gold-plated over nickel
Contact material	Copper alloy
Width	5.7 mm
Height	13.8 mm
Length	21.21 mm

Electrical characteristics

Rated current	2 A
Rated voltage (III/3)	250 V
Insulation resistance	10 TΩ

Environmental Product Compliance

REACH SVHC	Lead 7439-92-1
------------	----------------

D-SUB coaxial contact - VS-ST-KX-50-LP - 1655522

Technical data

Environmental Product Compliance

China RoHS	Environmentally Friendly Use Period = 50 years
	For details about hazardous substances go to tab "Downloads", Category "Manufacturer's declaration"

Drawings

Dimensional drawing

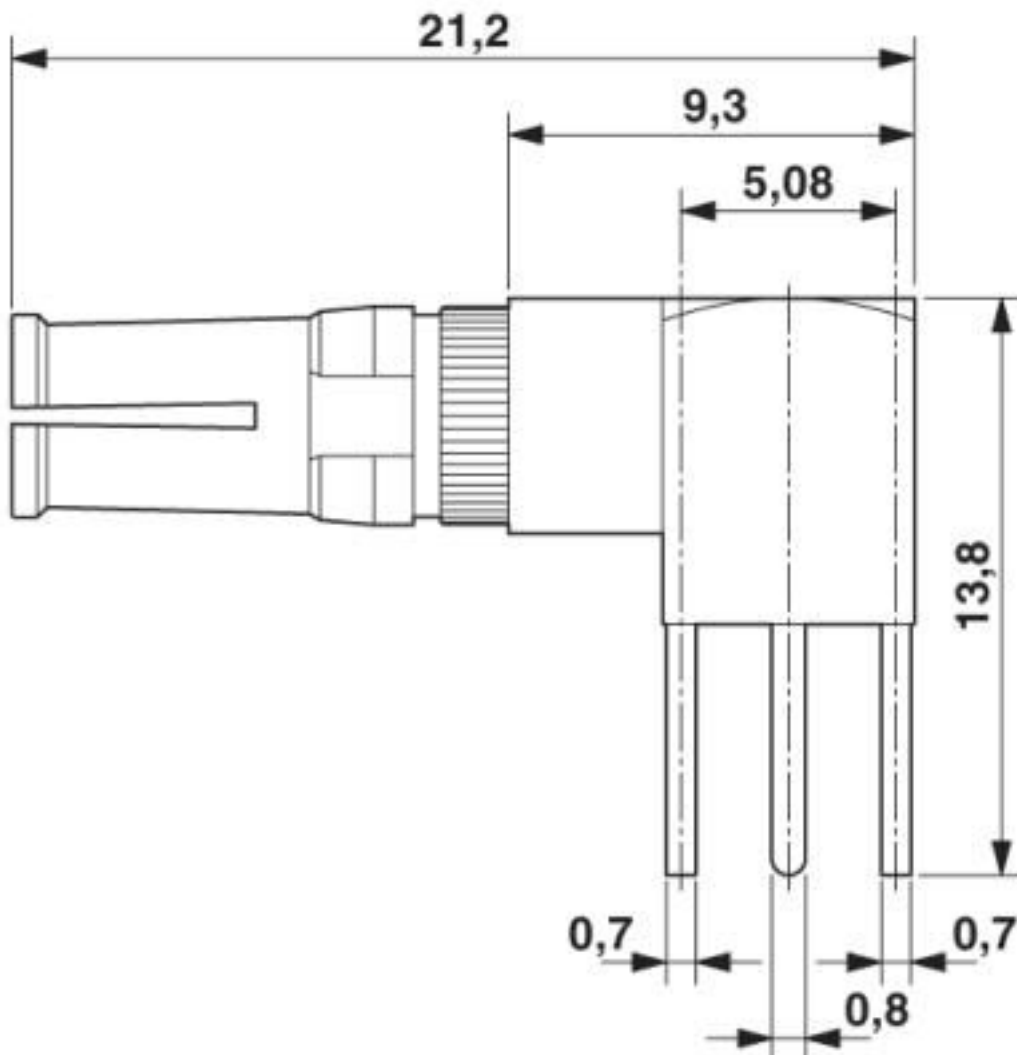

D-SUB coaxial contact pin

Classifications

eCI@ss

eCI@ss 10.0.1	27440204
---------------	----------

D-SUB coaxial contact - VS-ST-KX-50-LP - 1655522

Classifications

eCl@ss

eCl@ss 4.0	27260700
eCl@ss 4.1	27260700
eCl@ss 5.0	27260700
eCl@ss 5.1	27261200
eCl@ss 6.0	27261200
eCl@ss 7.0	27440204
eCl@ss 8.0	27440204
eCl@ss 9.0	27440204

ETIM

ETIM 2.0	EC000796
ETIM 3.0	EC000796
ETIM 4.0	EC000796
ETIM 5.0	EC000796
ETIM 6.0	EC000796
ETIM 7.0	EC000796

UNSPSC

UNSPSC 6.01	30211923
UNSPSC 7.0901	39121522
UNSPSC 11	39121522
UNSPSC 12.01	39121522
UNSPSC 13.2	39121522
UNSPSC 18.0	39121522
UNSPSC 19.0	39121522
UNSPSC 20.0	39121522
UNSPSC 21.0	39121522

Approvals

Approvals

Approvals

EAC

Ex Approvals

Approval details

D-SUB coaxial contact - VS-ST-KX-50-LP - 1655522

Approvals

EAC



B.01687

Accessories

Accessories

Assembly tool

Contact removal tool - HC-M4-KOAX-EWZ - 1676747



Contact removal tool for coaxial contacts

Phoenix Contact 2020 © - all rights reserved
<http://www.phoenixcontact.com>

PHOENIX CONTACT GmbH & Co. KG
Flachsmarktstr. 8
32825 Blomberg
Germany
Tel. +49 5235 300
Fax +49 5235 3 41200
<http://www.phoenixcontact.com>

Mouser Electronics

Authorized Distributor

Click to View Pricing, Inventory, Delivery & Lifecycle Information:

[Phoenix Contact:](#)

[1655522](#)