

D-SUB protective cover - VS-25-SD - 1652211

Please be informed that the data shown in this PDF Document is generated from our Online Catalog. Please find the complete data in the user's documentation. Our General Terms of Use for Downloads are valid (<http://phoenixcontact.com/download>)

D-SUB protective cover, shell size 3, IP54 degree of protection, for panel mounting frame and sleeve housing VS-25-...



Key Commercial Data

Packing unit	5 pc
GTIN	
GTIN	4017918917142

Technical data

Mechanical characteristics

Locking type	without
Weight	9.17 g
Flammability rating according to UL 94	V0

Ambient conditions

Ambient temperature (operation)	-40 °C ... 80 °C
---------------------------------	------------------

Material data

Housing material	PA
------------------	----

Standards and Regulations

Flammability rating according to UL 94	V0
--	----

Environmental Product Compliance

China RoHS	Environmentally friendly use period: unlimited = EFUP-e
	No hazardous substances above threshold values

Drawings

D-SUB protective cover - VS-25-SD - 1652211

Dimensional drawing

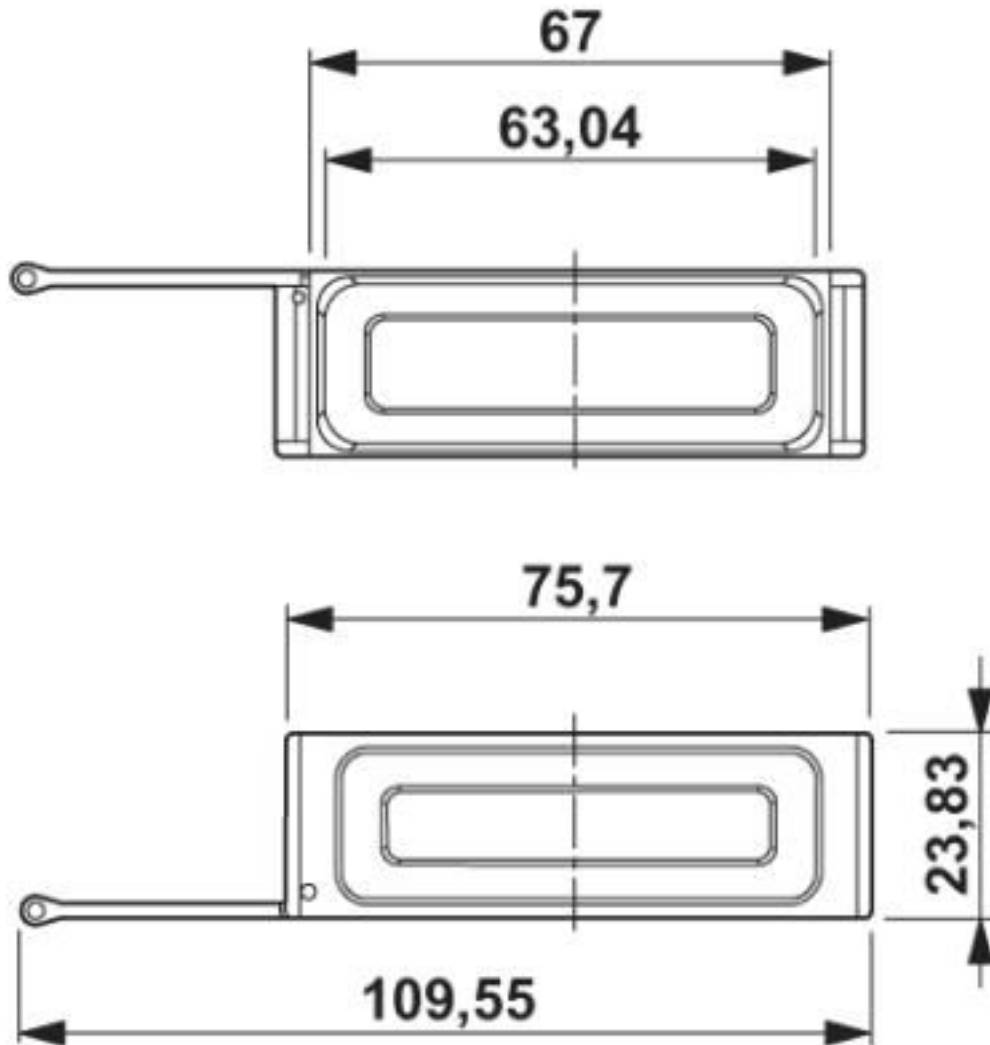

Protective cover for D-SUB

Classifications

eCl@ss

eCl@ss 10.0.1	27440208
eCl@ss 4.0	27260700
eCl@ss 4.1	27260700
eCl@ss 5.0	27260700
eCl@ss 5.1	27260700
eCl@ss 6.0	27261200
eCl@ss 7.0	27440208
eCl@ss 8.0	27440208

D-SUB protective cover - VS-25-SD - 1652211

Classifications

eCl@ss

eCl@ss 9.0	27440208
------------	----------

ETIM

ETIM 2.0	EC000437
ETIM 3.0	EC000437
ETIM 4.0	EC001133
ETIM 5.0	EC002314
ETIM 6.0	EC002314
ETIM 7.0	EC002314

UNSPSC

UNSPSC 6.01	31261501
UNSPSC 7.0901	31261501
UNSPSC 11	31261501
UNSPSC 12.01	31261501
UNSPSC 13.2	39121421
UNSPSC 18.0	39121421
UNSPSC 19.0	39121421
UNSPSC 20.0	39121421
UNSPSC 21.0	39121421

Approvals

Approvals

Approvals

EAC

Ex Approvals

Approval details

EAC		B.01742
-----	---	---------

Accessories

Accessories

Panel mounting frame

D-SUB protective cover - VS-25-SD - 1652211

Accessories

D-SUB panel mounting frames - VS-25-A - 1689750



D-SUB panel mounting frame, shell size 3, IP67 degree of protection

Phoenix Contact 2020 © - all rights reserved
<http://www.phoenixcontact.com>

PHOENIX CONTACT GmbH & Co. KG
Flachsmarktstr. 8
32825 Blomberg
Germany
Tel. +49 5235 300
Fax +49 5235 3 41200
<http://www.phoenixcontact.com>

Mouser Electronics

Authorized Distributor

Click to View Pricing, Inventory, Delivery & Lifecycle Information:

[Phoenix Contact:](#)

[1652211](#)