

AC charging cable - EV-T2M3C-1AC32A-10,0M6,0ESBK00 - 1623809

Please be informed that the data shown in this PDF Document is generated from our Online Catalog. Please find the complete data in the user's documentation. Our General Terms of Use for Downloads are valid (<http://phoenixcontact.com/download>)



Design line 1, AC charging cable with Vehicle Connector, open cable end, with protective cap, Type 2, IEC 62196-2, 32 A / 250 V (AC), cable: 10 m, black, straight, NOTE: Signal transmission is dependent on the cable length and may be adversely affected.

Product Description

AC charging cable with Vehicle Connector and open cable end for charging electric vehicles (EV) with alternating current (AC) via type 2 Vehicle Inlets, for installation at charging stations for E-Mobility (EVSE)

Your advantages

- ✓ Consistent design of all Phoenix Contact Vehicle Connectors and Infrastructure Plugs
- ✓ Silver-plated surface of the power and signal contacts
- ✓ Certified in accordance with IATF 16949:2016 and ISO 9001:2015
- ✓ Convenient handling, thanks to the ergonomic handle and additional, rubber grip components



Key Commercial Data

Packing unit	1 pc
GTIN	 4 0 5 5 6 2 6 1 8 9 2 1 5
GTIN	4055626189215

Technical data

Product definition

Type	D-Line
Application	AC charging cable with Vehicle Connector, open cable end, with protective cap
Standards/regulations	IEC 62196-2
Charging standard	Type 2
Charging mode	Mode 3, Case C
Note	NOTE: Signal transmission is dependent on the cable length and may be adversely affected.
	The cable capacity must therefore be assessed in the overall system of the charging station and must not exceed 3100 pF (IEC 61851-1, Annex A, Table A.2, Note d).

AC charging cable - EV-T2M3C-1AC32A-10,0M6,0ESBK00 - 1623809

Technical data

Product definition

	Interference-free V2G communication in accordance with ISO 15118 is not guaranteed for cable lengths over 10 m (ISO IEC 15118-3, A.11.3, Table A.11).
	Cable management is required in certain regions if the cable length exceeds 5.0 m (Switzerland) or 7.5 m (USA) (IEC 61851-1).

Dimensions

Vehicle connector width	60.00 mm
Vehicle connector height	102.90 mm
Vehicle connector depth	229.60 mm
Conductor length	10 m
Stripping length	45 mm ±10 mm

Ambient conditions

Ambient temperature (operation)	-30 °C ... 50 °C
Ambient temperature (storage/transport)	-40 °C ... 80 °C
Max. altitude	5000 m (above sea level)
Degree of protection	IP44 (plugged in; when plugged in and ready to operate, the degree of protection is only ensued if both plug-in components are original products from Phoenix Contact or suitable standard-compliant products)
	IP44 (Protective cap)

Electrical properties

Maximum charging power	8 kW
Number of phases	1
Number of power contacts	3 (L1, N, PE)
Rated current of power contacts	32 A
Rated voltage for power contacts	250 V AC
Number of signal contacts	2 (CP, PP)
Rated current for signal contacts	2 A
Rated voltage for signal contacts	30 V AC
Type of signal transmission	Pulse width modulation
Note on the connection method	Crimp connection, cannot be disconnected
Resistor coding	220 Ω (between PE and PP)

Mechanical properties

Insertion/withdrawal cycles	> 10000
Insertion force	< 100 N
Withdrawal force	< 100 N

Design

Design line	D-Line
Housing color	black
Mating face color	gray
Color handle area	gray

AC charging cable - EV-T2M3C-1AC32A-10,0M6,0ESBK00 - 1623809

Technical data

Design

Color protective cap	black
Label	14.1 mm x 44.8 mm (customer logo on request)

Material

Housing material	Plastic
Material handle area	Soft plastic
Material protective cap	Soft plastic
Material mating face	Plastic
Material surface of contacts	Ag

Cable

Cable structure	3 x 6.0 mm ² + 1 x 0.5 mm ²
Wiring standards/regulations	prEN 50620 / DIN EN 50620
Wiring class	Class 5
Wiring certifications	VDE
External cable diameter	12.8 mm ±0.4 mm
Type of conductor	straight
Cable resistance	≤ 0.0033 Ω/m (based on a power core, at an ambient temperature of 20°C)
Outer sheath, material	TPE-U
External sheath, color	black
Minimum bending radius	96 mm (7.5 x diameter)
Cable weight	max. 305 kg/km

Locking

Locking type	No locking option for U-lock
--------------	------------------------------

Environmental Product Compliance

China RoHS	Environmentally Friendly Use Period = 10;
	For details about hazardous substances go to tab "Downloads", Category "Manufacturer's declaration"

Drawings

AC charging cable - EV-T2M3C-1AC32A-10,0M6,0ESBK00 - 1623809

Schematic diagram

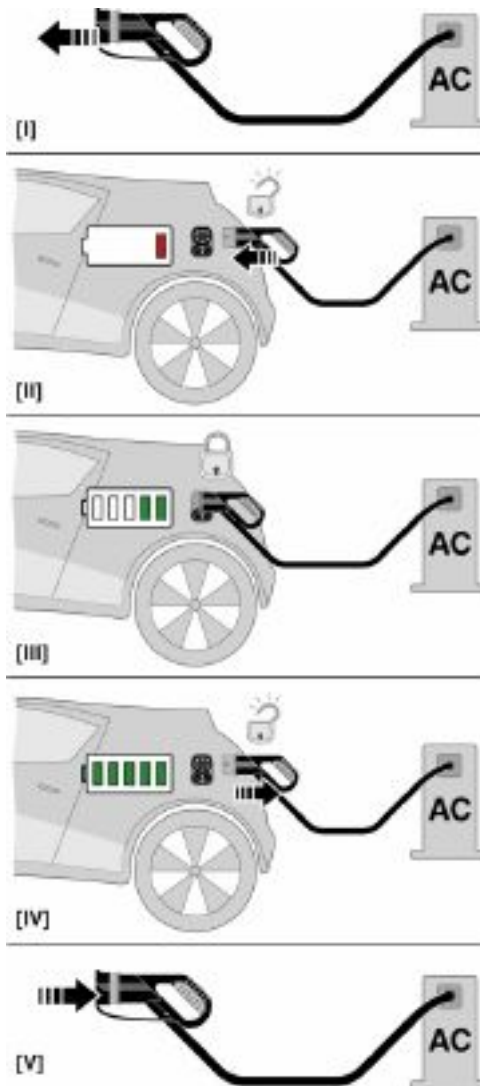

Operating instructions

AC charging cable - EV-T2M3C-1AC32A-10,0M6,0ESBK00 - 1623809

Dimensional drawing

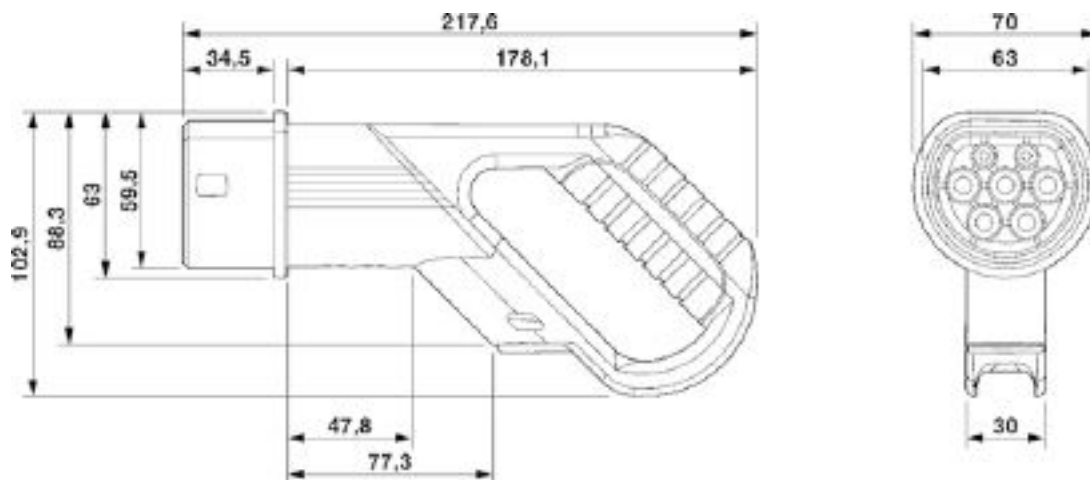

Ensure that the vehicle connector is placed in an appropriate resting position that ensures a minimum protection rating of IP24 in accordance with IEC 61851-1 for the entire time between charging. Use the dimensions of the vehicle connector to create this type of resting position. Detailed specifications can also be found in the download area.

Schematic diagram

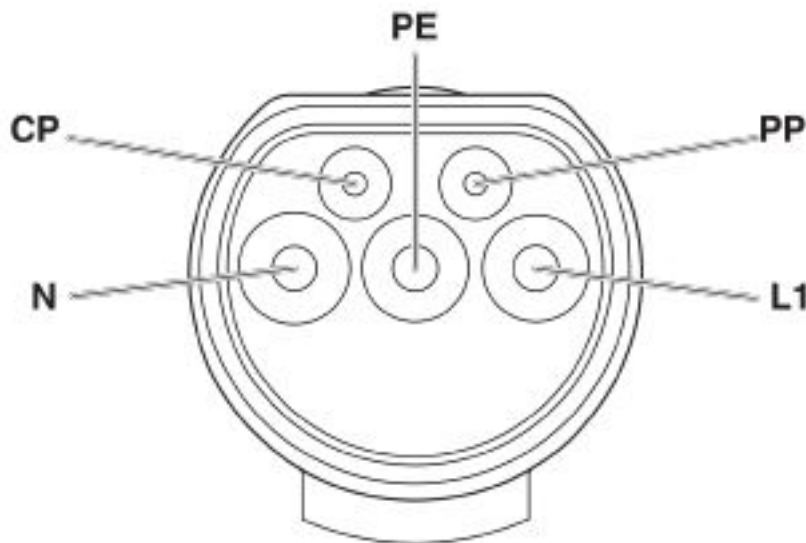

Pin assignment of the Vehicle Connector

Classifications

eCI@ss

eCI@ss 4.0	27140800
eCI@ss 4.1	27140800
eCI@ss 5.0	27143400
eCI@ss 5.1	27143400

AC charging cable - EV-T2M3C-1AC32A-10,0M6,0ESBK00 - 1623809

Classifications

eCl@ss

eCl@ss 6.0	27143400
eCl@ss 7.0	27449001
eCl@ss 8.0	27449001

ETIM

ETIM 3.0	EC002061
ETIM 4.0	EC002061
ETIM 5.0	EC002839
ETIM 6.0	EC002897
ETIM 7.0	EC002897

UNSPSC

UNSPSC 6.01	30211923
UNSPSC 7.0901	39121522
UNSPSC 11	39121522
UNSPSC 12.01	39121522
UNSPSC 13.2	39121522
UNSPSC 18.0	39121522
UNSPSC 19.0	39121522
UNSPSC 20.0	39121522
UNSPSC 21.0	39121522

Approvals

Approvals

Approvals

VDE Zeichengenehmigung / IECCE CB Scheme

Ex Approvals

Approval details

VDE Zeichengenehmigung		http://www2.vde.com/de/Institut/Online-Service/VDE-gepruefteProdukte/Seiten/Online-Suche.aspx	40037319
Nominal voltage UN	250 V		
Nominal current IN	32 A		
mm ² /AWG/kcmil	6		

AC charging cable - EV-T2M3C-1AC32A-10,0M6,0ESBK00 - 1623809

Approvals

IECEE CB Scheme	CB scheme	http://www.iecee.org/	DE1-61387
Nominal voltage UN		250 V	
Nominal current IN		32 A	

Accessories

Accessories

AC charging controller

AC charging controller - EV-CC-AC1-M3-CC-SER-HS - 1622459



The EV-CC-AC1-M3-CBC-SER-HS charging controller with housing for DIN rail mounting is used for charging electric vehicles at 3-phase AC networks according to IEC 61851-1, Mode 3. Optimized for charging stations with permanently mounted Vehicle Connector. All charging functions and comprehensive configuration settings are already integrated.

AC charging controller - EV-CC-AC1-M3-CC-SER-PCB - 1622460



The EV-CC-AC1-M3-CC-SER-PCB charging controller as a PCB for charging electric vehicles on a 3-phase AC power grid according to IEC 61851-1, Mode 3. Optimized for charging stations with permanently mounted Vehicle Connector. All charging functions and comprehensive configuration settings are already integrated.

AC charging controller - EV-CC-AC1-M3-CC-SER-PCB-XC-25X - 1627742



The EV-CC-AC1-M3-CC-SER-PCB charging controller as a PCB for charging electric vehicles on a 3-phase AC power grid according to IEC 61851-1, Mode 3. Optimized for charging stations with permanently mounted Vehicle Connector. All charging functions and comprehensive configuration settings are already integrated.

AC charging controller - EV-CC-AC1-M3-CC-SER-PCB-MSTB - 1627367



The EV-CC-AC1-M3-CC-SER-PCB-MSTB charging controller as a PCB for charging electric vehicles according to IEC 61851-1, Mode 3, optimized for charging stations with permanently mounted Vehicle Connector. Connection via PCB connector on header.

AC charging cable - EV-T2M3C-1AC32A-10,0M6,0ESBK00 - 1623809

Accessories

AC charging controller - EM-CP-PP-ETH - 2902802



EV charge control is used to charge electrical vehicles on the 3-phase AC mains power supply according to IEC 61851-1 Mode 3. All necessary control functions are integrated. Additional functions are available for various charging applications.

Park position

Park position - EV-T2AC-PARK - 1624148



Park position, Retainer for Vehicle Connector as parking position at charging stations (EVSE), Type 2, IEC 62196-2, Front mounting

Phoenix Contact 2020 © - all rights reserved
<http://www.phoenixcontact.com>

PHOENIX CONTACT GmbH & Co. KG
Flachsmarktstr. 8
32825 Blomberg
Germany
Tel. +49 5235 300
Fax +49 5235 3 41200
<http://www.phoenixcontact.com>

Mouser Electronics

Authorized Distributor

Click to View Pricing, Inventory, Delivery & Lifecycle Information:

[Phoenix Contact:](#)

[1623809](#)