

# Locking - EV-T2M3S-E-LOCK24V - 1622317

Please be informed that the data shown in this PDF Document is generated from our Online Catalog. Please find the complete data in the user's documentation. Our General Terms of Use for Downloads are valid (<http://phoenixcontact.com/download>)

Locking, For attaching to infrastructure charging sockets, Type 2, GB/T, IEC 61851-1, length: 0.5 m, Locking actuator: 24 V, 4-position, Can be positioned flexibly, Generation 1



## Product Description

Locking actuator with 24 V power supply for Infrastructure Socket Outlets and Vehicle Inlets

### Your advantages

- Certified in accordance with IATF 16949:2016 and ISO 9001:2015
- Material data available in the IMDS (International Material Data System of the automotive industry)
- Manual emergency release of the locking actuator
- Integrated interlock during charging



## Key Commercial Data

Packing unit	1 pc
GTIN	
GTIN	4055626033808

## Technical data

### Product definition

Application	For attaching to infrastructure charging sockets
Design	Generation 1
Standards/regulations	IEC 61851-1
Charging standard	Type 2
	GB/T
Charging mode	Mode 2, 3, 4

### Dimensions

Conductor length	0.5 m (Locking actuator cables)
------------------	---------------------------------

### Ambient conditions

# Locking - EV-T2M3S-E-LOCK24V - 1622317

## Technical data

### Ambient conditions

Ambient temperature (operation)	-30 °C ... 50 °C
Ambient temperature (storage/transport)	-40 °C ... 80 °C
Max. altitude	5000 m (above sea level)

### Mounting

Possible mounting positions	Can be positioned flexibly
-----------------------------	----------------------------

### Design

Design line	Generation 1
Housing color	black

### Locking actuator

Number of positions of theconnectors	4
Operating voltage	24 V (Typical power supply at the motor)
Possible power supply range at the motor	22 V ... 26 V
Maximum voltage for locking detection	30 V
Typical motor current for locking	0.05 A
Reverse current of the motor	max. 0.5 A
Max. dwell time with reverse current	1000 ms
Recommended adaptation time	600 ms
Pause time after entry or exit path	3 s
Service life insertion cycles	> 10000 load cycles
Ambient temperature (operation)	-30 °C ... 50 °C
Cable length	0.5 m
Cable structure	4 x 0.5 mm <sup>2</sup>
Lock recognition	available
Mechanical emergency release	available

### Environmental Product Compliance

China RoHS	Environmentally Friendly Use Period = 10;
	For details about hazardous substances go to tab "Downloads", Category "Manufacturer's declaration"

## Drawings

# Locking - EV-T2M3S-E-LOCK24V - 1622317

Schematic diagram

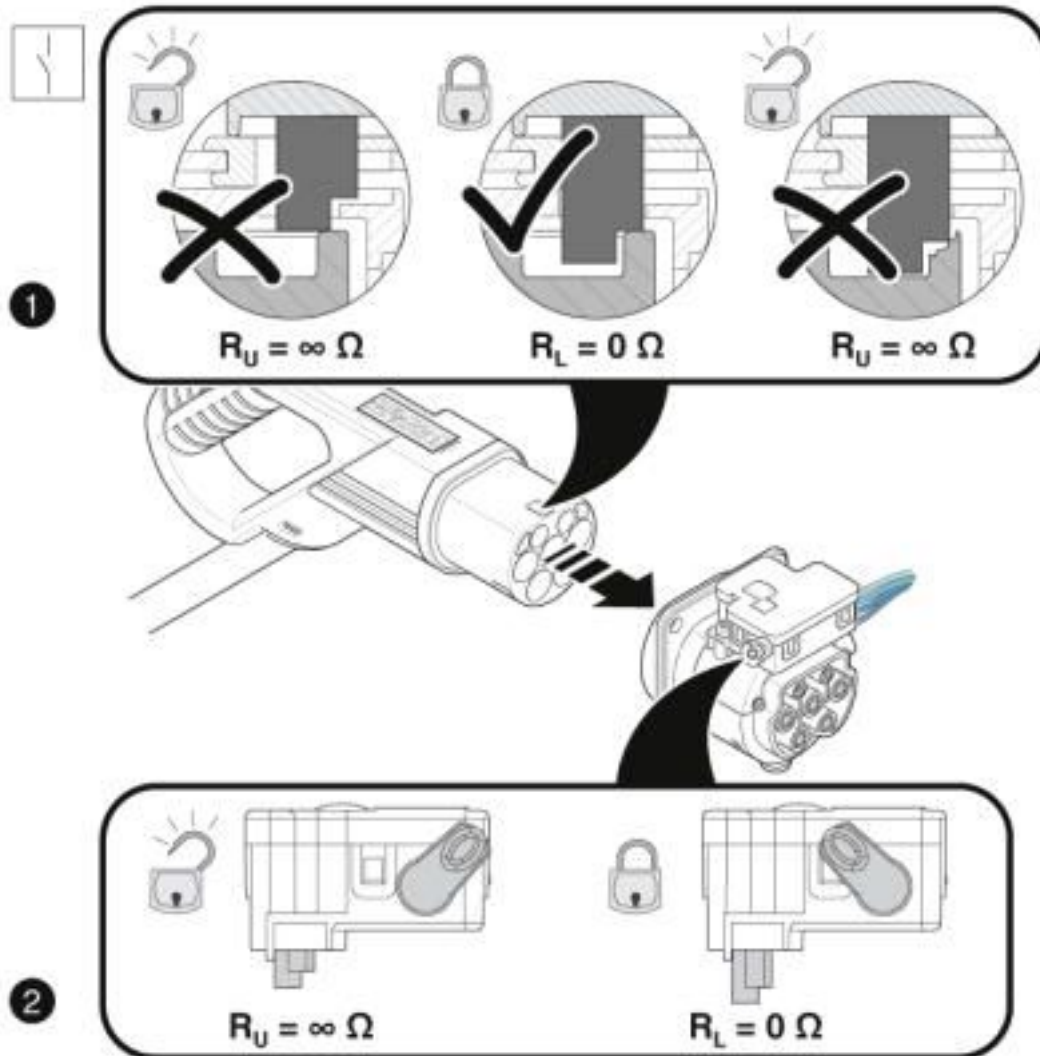

Detection of the Infrastructure Plug

# Locking - EV-T2M3S-E-LOCK24V - 1622317

Diagram

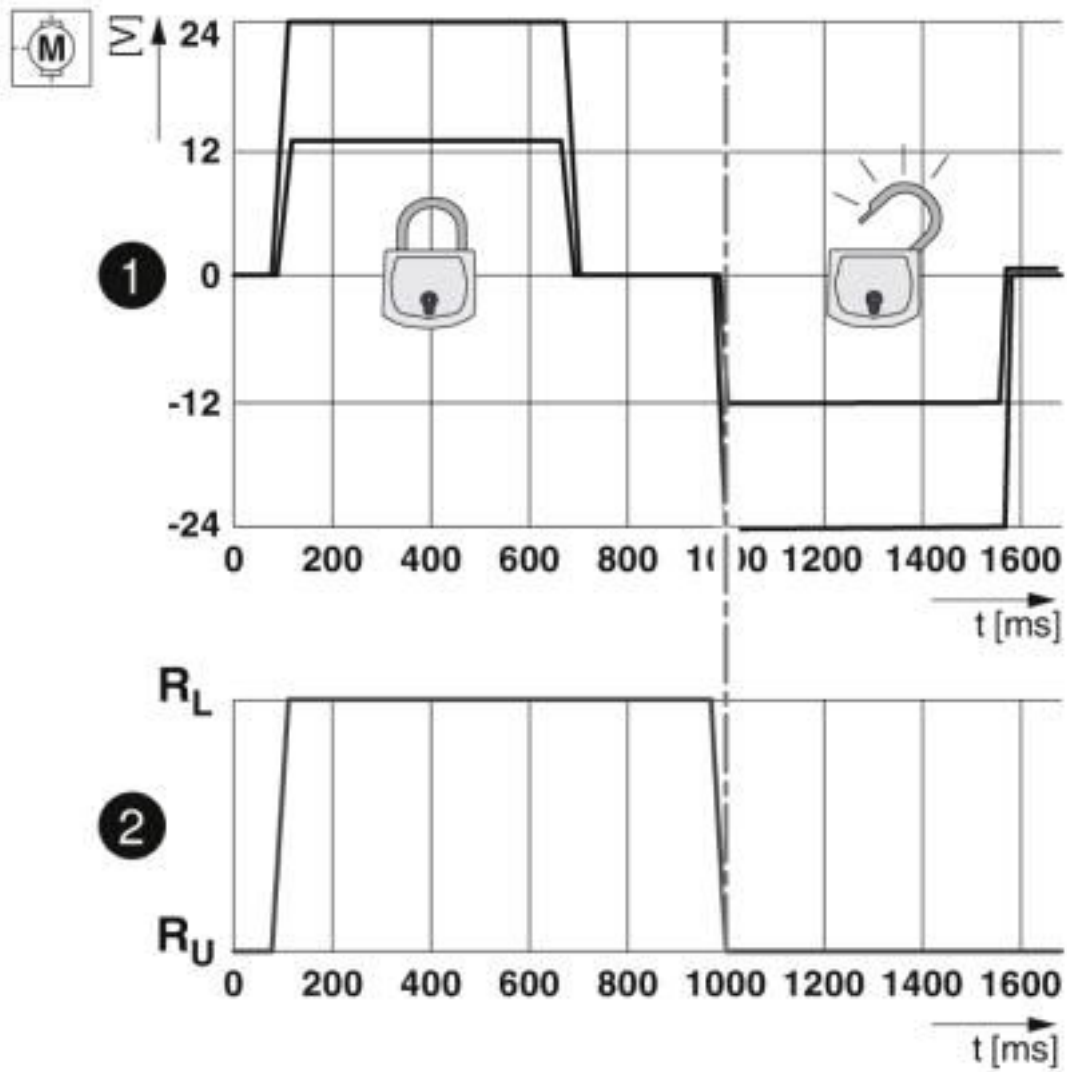

Locking states of the locking actuator

# Locking - EV-T2M3S-E-LOCK24V - 1622317

Block diagram

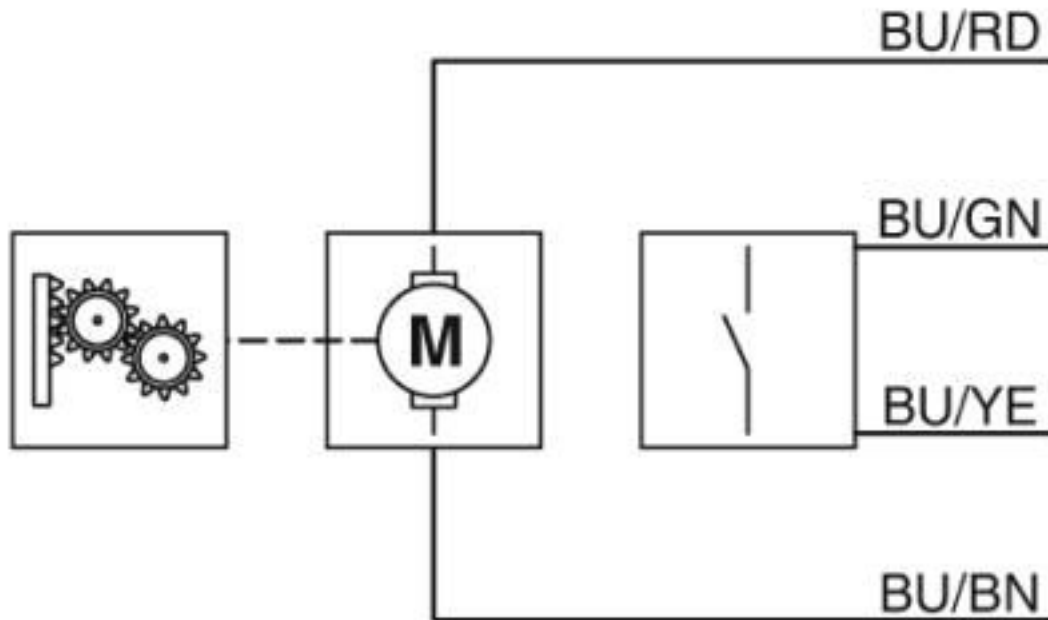

Block diagram of the locking actuator

Schematic diagram

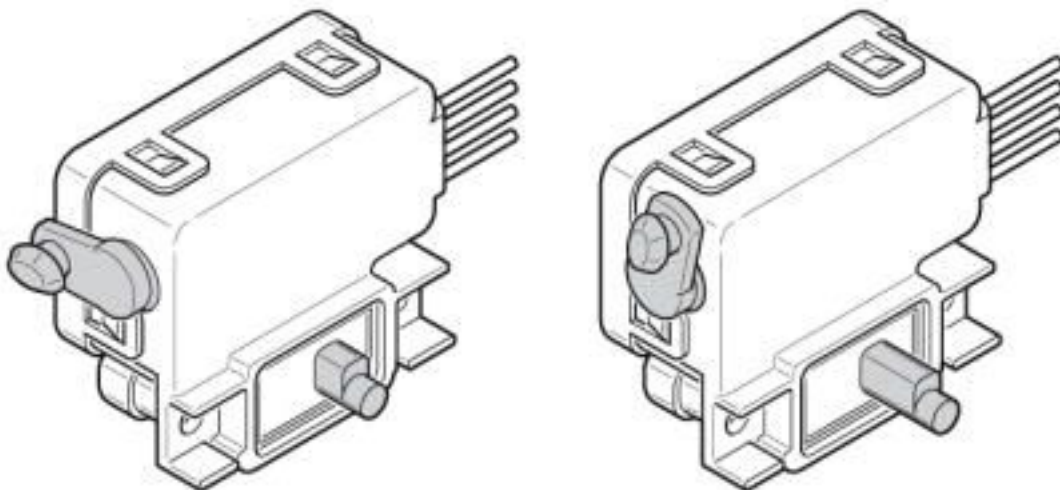

Lever positions for emergency release

# Locking - EV-T2M3S-E-LOCK24V - 1622317

Schematic diagram



Lever positions for emergency release

## Classifications

eCl@ss

eCl@ss 10.0.1	27144792
eCl@ss 4.0	27141200
eCl@ss 4.1	27141200
eCl@ss 5.0	27149100
eCl@ss 5.1	27149100
eCl@ss 6.0	27261200
eCl@ss 7.0	27440208
eCl@ss 8.0	27440208
eCl@ss 9.0	27144792

ETIM

ETIM 2.0	EC000241
ETIM 3.0	EC002061
ETIM 4.0	EC002061
ETIM 5.0	EC002314
ETIM 6.0	EC002884
ETIM 7.0	EC002884

UNSPSC

UNSPSC 6.01	30211923
UNSPSC 7.0901	39121522
UNSPSC 11	39121522
UNSPSC 12.01	39121522
UNSPSC 13.2	39121522
UNSPSC 18.0	39121522
UNSPSC 19.0	39121522

## Locking - EV-T2M3S-E-LOCK24V - 1622317

### Classifications

#### UNSPSC

UNSPSC 20.0	39121522
UNSPSC 21.0	39121522

### Accessories

#### Additional products

Holder - EV-T2M3S-E-LOCK-HOLDER - 1065832

Holder, Locking actuator brackets for infrastructure socket outlets, Type 2, GB/T, IEC 61851-1, Generation 1

---

Phoenix Contact 2020 © - all rights reserved  
<http://www.phoenixcontact.com>

PHOENIX CONTACT GmbH & Co. KG  
Flachsmarktstr. 8  
32825 Blomberg  
Germany  
Tel. +49 5235 300  
Fax +49 5235 3 41200  
<http://www.phoenixcontact.com>

# Mouser Electronics

Authorized Distributor

Click to View Pricing, Inventory, Delivery & Lifecycle Information:

[Phoenix Contact:](#)

[1622317](#)