

AC charging cable - EV-T1M3C-1AC32A-6,0M6,0ESBK00 - 1622285

Please be informed that the data shown in this PDF Document is generated from our Online Catalog. Please find the complete data in the user's documentation. Our General Terms of Use for Downloads are valid (<http://phoenixcontact.com/download>)



Design line 1, AC charging cable with Vehicle Connector, open cable end, with protective cap, Type 1, IEC 62196-2, SAE J1772, 32 A / 250 V (AC), cable: 6 m, black, straight, NOTE: Cable management may be required.

Product Description

AC charging cable with Vehicle Connector and open cable end for charging electric vehicles (EV) with alternating current (AC) via type 1 Vehicle Inlets, for installation at charging stations for E-Mobility (EVSE)

Your advantages

- Consistent design of all Phoenix Contact Vehicle Connectors and Infrastructure Plugs
- Silver-plated surface of the power and signal contacts
- Certified in accordance with IATF 16949:2016 and ISO 9001:2015
- Convenient handling, thanks to the ergonomic handle and additional, rubber grip components



Key Commercial Data

Packing unit	1 pc
GTIN	
GTIN	4055626027029

Technical data

Product definition

Type	D-Line
Application	AC charging cable with Vehicle Connector, open cable end, with protective cap
Standards/regulations	IEC 62196-2 SAE J1772
Charging standard	Type 1
Charging mode	Mode 3, Case C
Note	NOTE: Cable management may be required. Cable management is required in certain regions if the cable length exceeds 5.0 m (Switzerland) or 7.5 m (USA) (IEC 61851-1).

AC charging cable - EV-T1M3C-1AC32A-6,0M6,0ESBK00 - 1622285

Technical data

Dimensions

Vehicle connector width	55.20 mm
Vehicle connector height	72.60 mm
Vehicle connector depth	235.90 mm
Conductor length	6 m
Stripping length	45 mm ±10 mm

Ambient conditions

Ambient temperature (operation)	-30 °C ... 50 °C
Ambient temperature (storage/transport)	-40 °C ... 80 °C
Max. altitude	5000 m (above sea level)
Degree of protection	IP44 (plugged in)
	IP54 (Protective cap)
	The degree of protection is only ensured in the ready and plugged-in state when both plug-in components are original products from Phoenix Contact or suitable standard-compliant products.

Electrical properties

Maximum charging power	8 kW
Number of phases	1
Number of power contacts	3 (L1, N, PE)
Rated current of power contacts	32 A
Rated voltage for power contacts	250 V AC
Number of signal contacts	2 (CP, CS)
Rated current for signal contacts	2 A
Rated voltage for signal contacts	30 V AC
Type of signal transmission	Pulse width modulation
Note on the connection method	Crimp connection, cannot be disconnected
Resistor coding	480 Ω (Lever actuated)
	150 Ω (Lever not actuated)

Mechanical properties

Insertion/withdrawal cycles	> 10000
Insertion force	< 75 N
Withdrawal force	< 75 N

Design

Design line	D-Line
Housing color	black
Mating face color	gray
Color handle area	gray
Actuating element color	gray
Color protective cap	black
Label	14.1 mm x 44.8 mm (customer logo on request)

AC charging cable - EV-T1M3C-1AC32A-6,0M6,0ESBK00 - 1622285

Technical data

Material

Housing material	Plastic
Material handle area	Soft plastic
Actuating lever material	Metal
Material protective cap	Soft plastic
Material mating face	Plastic
Material surface of contacts	Ag

Cable

Cable structure	3 x 6.0 mm ² + 1 x 0.5 mm ²
Wiring standards/regulations	prEN 50620 / DIN EN 50620
Wiring class	Class 5
Wiring certifications	VDE
External cable diameter	12.8 mm ±0.4 mm
Type of conductor	straight
Cable resistance	≤ 0.0033 Ω/m (based on a power core, at an ambient temperature of 20°C)
Outer sheath, material	TPE-U
External sheath, color	black
Minimum bending radius	96 mm (7.5 x diameter)
Cable weight	max. 305 kg/km

Locking

Locking type	No locking option for U-lock
--------------	------------------------------

Environmental Product Compliance

REACH SVHC	Lead 7439-92-1
China RoHS	Environmentally Friendly Use Period = 10;
	For details about hazardous substances go to tab "Downloads", Category "Manufacturer's declaration"

Drawings

AC charging cable - EV-T1M3C-1AC32A-6,0M6,0ESBK00 - 1622285

Schematic diagram

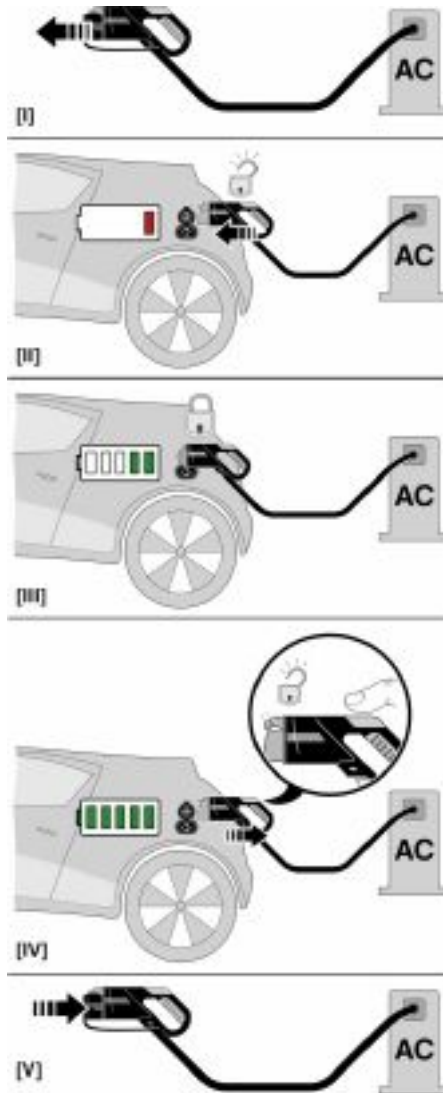

Operating instructions

AC charging cable - EV-T1M3C-1AC32A-6,0M6,0ESBK00 - 1622285

Connection diagram

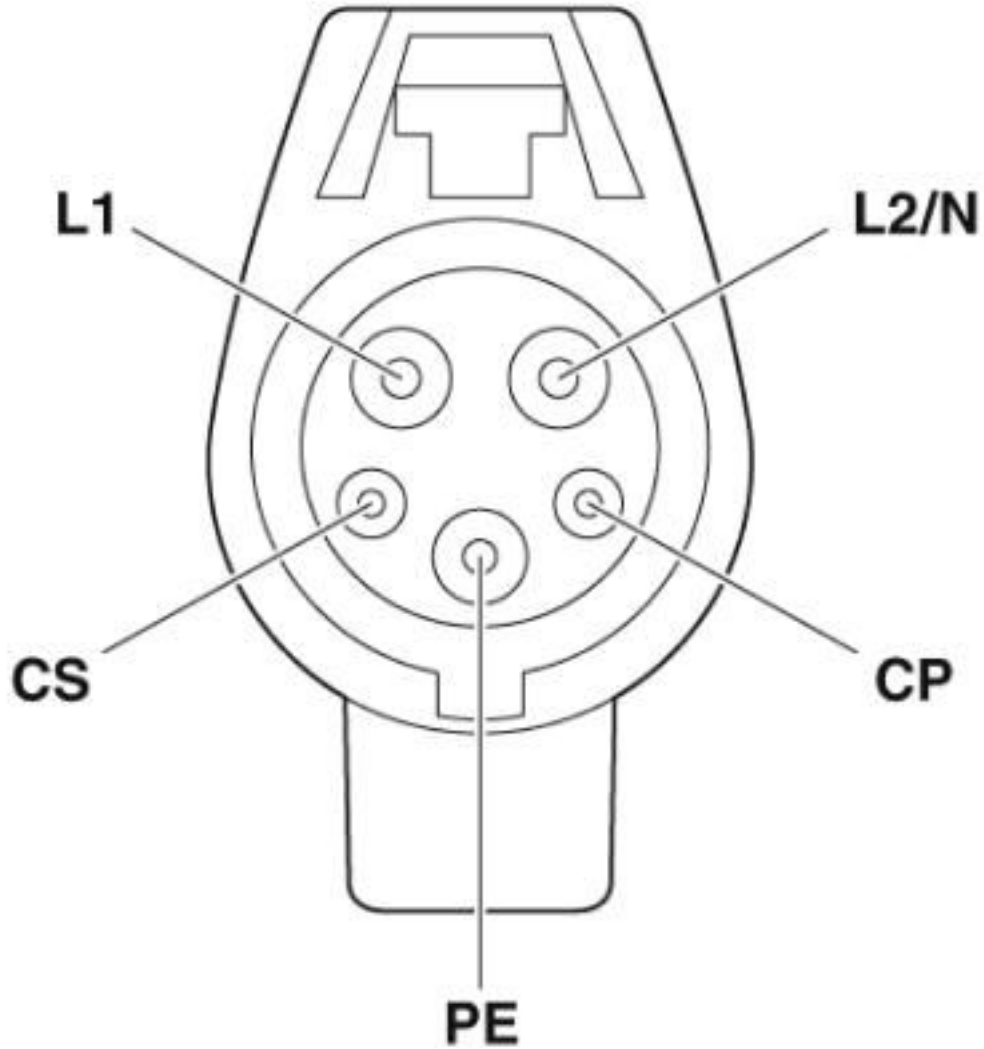

Pin assignment of the Vehicle Connector

AC charging cable - EV-T1M3C-1AC32A-6,0M6,0ESBK00 - 1622285

Dimensional drawing

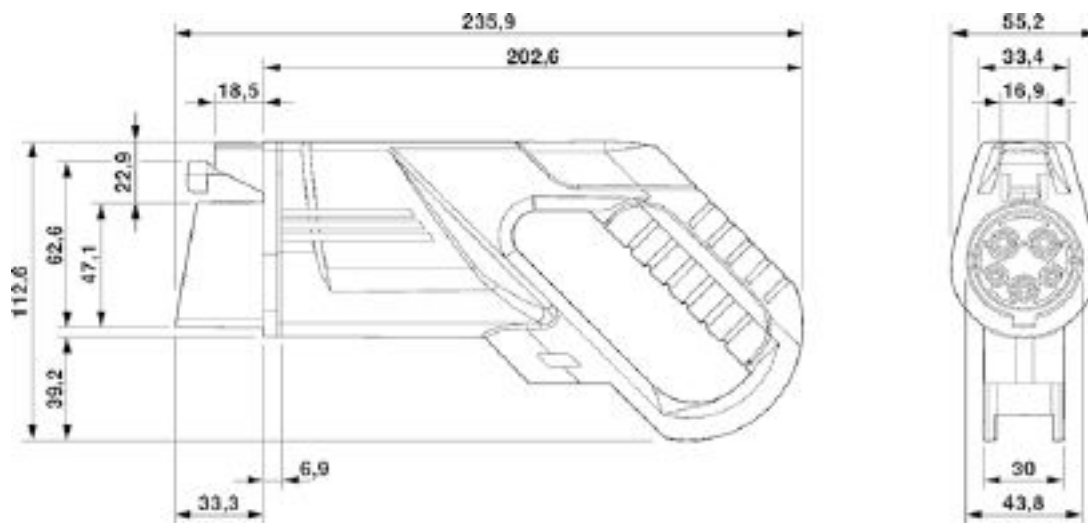

Ensure that the vehicle connector is placed in an appropriate resting position that ensures a minimum protection rating of IP24 in accordance with IEC 61851-1 for the entire time between charging. Use the dimensions of the vehicle connector to create this type of resting position. Detailed specifications can also be found in the download area.

Classifications

eCl@ss

eCl@ss 4.0	272607xx
eCl@ss 4.1	27260701
eCl@ss 5.0	27260701
eCl@ss 5.1	27143400
eCl@ss 6.0	27143400
eCl@ss 7.0	27449001
eCl@ss 8.0	27449001

ETIM

ETIM 3.0	EC002061
ETIM 4.0	EC002061
ETIM 5.0	EC002839
ETIM 6.0	EC002897
ETIM 7.0	EC002897

UNSPSC

UNSPSC 6.01	30211923
UNSPSC 7.0901	39121522
UNSPSC 11	39121522
UNSPSC 12.01	39121522
UNSPSC 13.2	39121522
UNSPSC 19.0	39121522

AC charging cable - EV-T1M3C-1AC32A-6,0M6,0ESBK00 - 1622285

Accessories

Accessories

Park position

Park position - EV-T1AC-PARK - 1624139



Park position, Retainer for Vehicle Connector as parking position at charging stations (EVSE), Type 1, SAE J1772, Front mounting

Phoenix Contact 2020 © - all rights reserved
<http://www.phoenixcontact.com>

PHOENIX CONTACT GmbH & Co. KG
Flachsmarktstr. 8
32825 Blomberg
Germany
Tel. +49 5235 300
Fax +49 5235 3 41200
<http://www.phoenixcontact.com>

Mouser Electronics

Authorized Distributor

Click to View Pricing, Inventory, Delivery & Lifecycle Information:

[Phoenix Contact:](#)

[1622285](#)