

# Panel feed-through - VS-PPC-F2-MSTB-MNNA-1R-SPSB5 - 1608252

Please be informed that the data shown in this PDF Document is generated from our Online Catalog. Please find the complete data in the user's documentation. Our General Terms of Use for Downloads are valid (<http://phoenixcontact.com/download>)



MSTB panel mounting frame, IP67, for push-pull interlocking, metal, with integrated contact insert for conductor connection, spring-cage connection, 400 V, for square mounting cutout, with seal, without mounting screws



## Key Commercial Data

Packing unit	1 pc
GTIN	
GTIN	4046356160056

## Technical data

### Dimensions

Width	36.2 mm
Height	42 mm
Length	41.9 mm

### Ambient conditions

Ambient temperature (operation)	-40 °C ... 70 °C
---------------------------------	------------------

### General data

Number of positions	5
Degree of pollution	2
Alternative short product description	Panel mounting frame for panel feed-through
Locking type	Push Pull
Rated voltage (III/3)	400 V
Conductor cross section	0.75 mm <sup>2</sup> ... 2.5 mm <sup>2</sup>
Connection cross section AWG	18 ... 13
Connection method	Spring-cage connection
Housing material	Zinc die-cast
Degree of protection	IP65/IP67
Rated current	16 A

# Panel feed-through - VS-PPC-F2-MSTB-MNNA-1R-SPSB5 - 1608252

## Technical data

### Standards and Regulations

Flammability rating according to UL 94	V0
--	----

## Drawings

Dimensional drawing

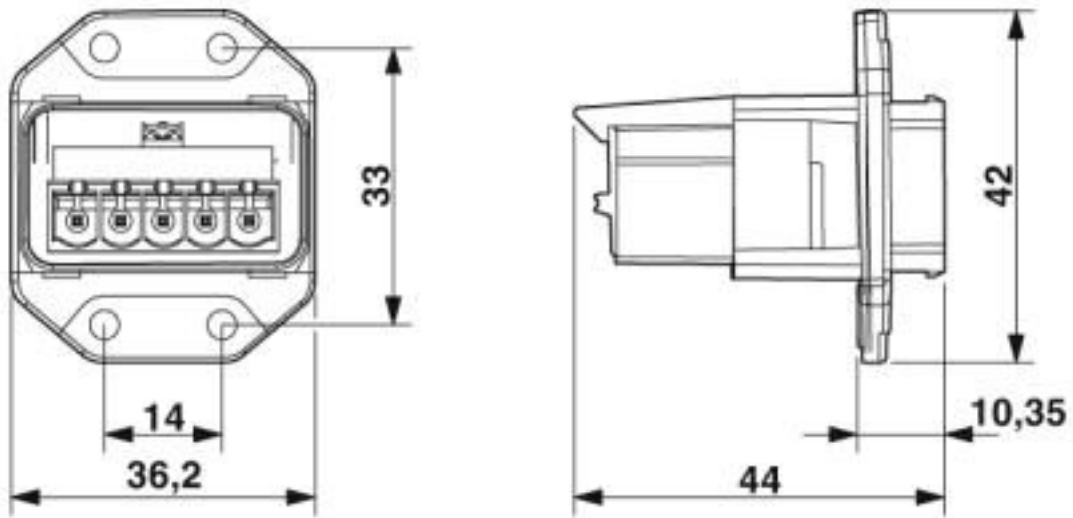

Push-Pull MSTB panel mounting frame

# Panel feed-through - VS-PPC-F2-MSTB-MNNA-1R-SPSB5 - 1608252

Dimensional drawing

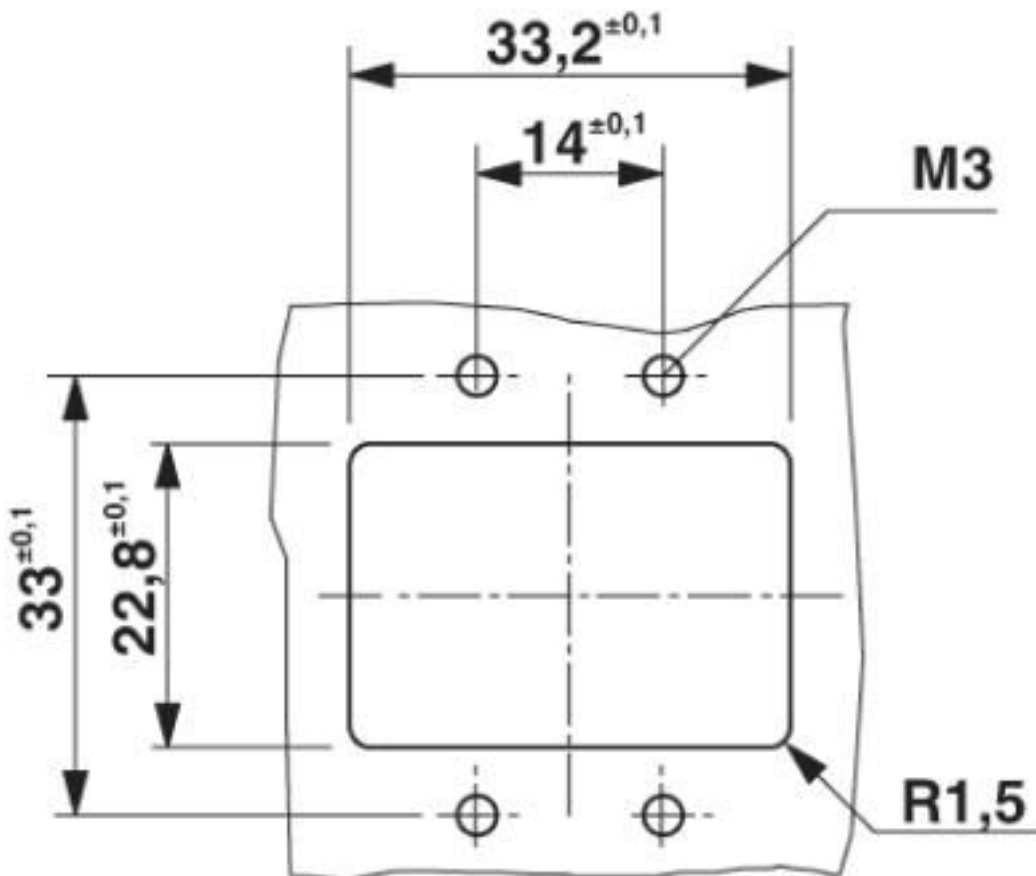

Mounting cutout

## Classifications

eCl@ss

eCl@ss 10.0.1	27440210
eCl@ss 4.0	27060700
eCl@ss 4.1	27060700
eCl@ss 5.0	27400200
eCl@ss 5.1	27400200
eCl@ss 6.0	27261200
eCl@ss 7.0	27440210
eCl@ss 8.0	27440210
eCl@ss 9.0	27440210

ETIM

ETIM 3.0	EC000516
ETIM 4.0	EC000516

# Panel feed-through - VS-PPC-F2-MSTB-MNNA-1R-SPSB5 - 1608252

## Classifications

### ETIM

ETIM 5.0	EC002310
ETIM 6.0	EC002310
ETIM 7.0	EC002310

### UNSPSC

UNSPSC 6.01	31261501
UNSPSC 7.0901	31261501
UNSPSC 11	31261501
UNSPSC 12.01	31261501
UNSPSC 13.2	39121421
UNSPSC 18.0	39121421
UNSPSC 19.0	39121421
UNSPSC 20.0	39121421
UNSPSC 21.0	39121421

## Approvals

### Approvals

Approvals

UL Recognized / EAC

Ex Approvals

### Approval details

UL Recognized		<a href="http://database.ul.com/cgi-bin/XYV/template/LISEXT/1FRAME/index.htm">http://database.ul.com/cgi-bin/XYV/template/LISEXT/1FRAME/index.htm</a>	FILE E 118976
Nominal voltage UN	400 V		
Nominal current IN	16 A		
mm <sup>2</sup> /AWG/kcmil	14		

EAC		B.01687
-----	---	---------

Phoenix Contact 2020 © - all rights reserved  
<http://www.phoenixcontact.com>

PHOENIX CONTACT GmbH & Co. KG  
Flachmarktstr. 8  
32825 Blomberg  
Germany  
Tel. +49 5235 300  
Fax +49 5235 3 41200  
<http://www.phoenixcontact.com>

# Mouser Electronics

Authorized Distributor

Click to View Pricing, Inventory, Delivery & Lifecycle Information:

[Phoenix Contact:](#)

[1608252](#)