

Housing - HC-B 10-SFQD-52/M2M20 - 1586840

Please be informed that the data shown in this PDF Document is generated from our Online Catalog. Please find the complete data in the user's documentation. Our General Terms of Use for Downloads are valid (<http://phoenixcontact.com/download>)



Box mounting base, for double locking latch, height 52 mm, with screw connection, 2x M20, with protective cover

RoHS

Key Commercial Data

Packing unit	10 pc
GTIN	
GTIN	4046356426930

Technical data

Dimensions

Height	52 mm
Width	52 mm
Length	93 mm
Wrench size, union nut	20 mm
External cable diameter	5 mm ... 12 mm (Cable 1)
	5 mm ... 12 mm (Cable 2)

Ambient conditions

Degree of protection of housing (IP)	IP65 (When plugged in)
Ambient temperature (operation)	-40 °C ... 125 °C

General

Note	For contact inserts HC-B10, BB18, DD42, M, K8/24
Size	B10
Housing type	Box mounting bases
Locking type	for double locking latch
No. of cable outlets	2
Cable outlet	lateral
Screw connection	with

Housing - HC-B 10-SFQD-52/M2M20 - 1586840

Technical data

General

Type of the screw connection	2x M20
Protective cover	yes
Housing material	Aluminum die-cast
Housing surface material	Powder-coated, gray
Seal material	NBR
Cable gland material	Nickel-plated brass
Cable seal material	NBR
Material, protective cover	PA

Environmental Product Compliance

China RoHS	Environmentally friendly use period: unlimited = EFUP-e
	No hazardous substances above threshold values

Drawings

Dimensional drawing

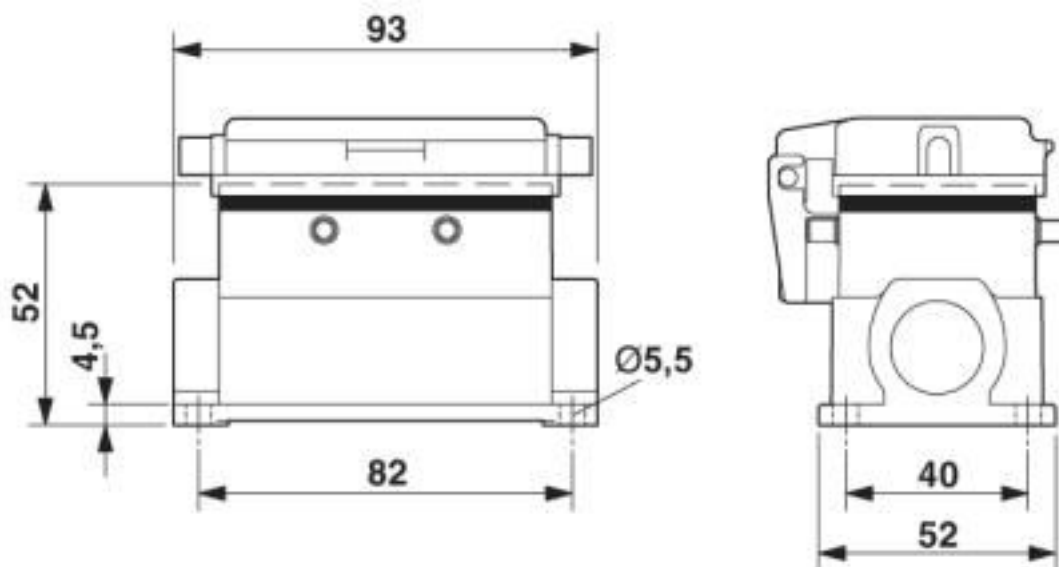

Classifications

eCl@ss

eCl@ss 4.0	272607xx
eCl@ss 4.1	27260701
eCl@ss 5.0	27143424
eCl@ss 5.1	27261200
eCl@ss 6.0	27261200
eCl@ss 7.0	27440202
eCl@ss 8.0	27440202

Housing - HC-B 10-SFQD-52/M2M20 - 1586840

Classifications

eCl@ss

eCl@ss 9.0	27440202
------------	----------

ETIM

ETIM 3.0	EC000437
ETIM 4.0	EC000437
ETIM 5.0	EC000437
ETIM 6.0	EC000437

UNSPSC

UNSPSC 6.01	31261502
UNSPSC 7.0901	31261502
UNSPSC 11	31261502
UNSPSC 12.01	31261502
UNSPSC 13.2	31261502

Accessories

Accessories

Full screw connection

Cable gland - HC-K-KV-M20(8-13) - 1690626



Plastic screw connection up to 5 bar, thread length: 8 mm, cable diameter: 8 - 13 mm, WAF 24, screw connection: M20

Cable gland - HC-M-KV-M20(11-16) - 1645998



Metal screw connection up to 5 bar, thread length: 6 mm, cable diameter: 11 - 16 mm, WAF 27, screw connection: M20

Cable gland - HC-M-KV-M20(1ASI) - 1584017



Metal screw connection for an AS-Interface flat-ribbon conductor, thread type M20

Phoenix Contact 2020 © - all rights reserved
<http://www.phoenixcontact.com>

PHOENIX CONTACT GmbH & Co. KG
Flachmarktstr. 8
32825 Blomberg
Germany
Tel. +49 5235 300
Fax +49 5235 3 41200
<http://www.phoenixcontact.com>

Mouser Electronics

Authorized Distributor

Click to View Pricing, Inventory, Delivery & Lifecycle Information:

[Phoenix Contact:](#)

[1586840](#)