

Housing - HC-B 32-AFS-72-EEE - 1580525

Please be informed that the data shown in this PDF Document is generated from our Online Catalog. Please find the complete data in the user's documentation. Our General Terms of Use for Downloads are valid (<http://phoenixcontact.com/download>)



HEAVYCON ADVANCE panel mounting base for B32 motor housing, for increased environmental requirements, EMC conductive, for Allen screw locking



Key Commercial Data

Packing unit	6 pc
GTIN	 4 046356 463218
GTIN	4046356463218

Technical data

Dimensions

Height	84.3 mm
Width	94 mm
Length	137.8 mm

Ambient conditions

Degree of protection of housing (IP)	IP66
	IP68 (0.2 bar/24 h)
	IP69K
Degree of protection of housing (NEMA)	4
	4X
	6P
	12
Ambient temperature (operation)	-40 °C ... 125 °C

General

Size	B32
Housing type	Panel mounting base
Locking type	Screw locking
Fixing screws	M6 (5 mm Allen screw)

Housing - HC-B 32-AFS-72-EEE - 1580525

Technical data

General

Screw connection	none
Housing material	Aluminum die-cast
Housing surface material	uncoated

Drawings

Dimensional drawing

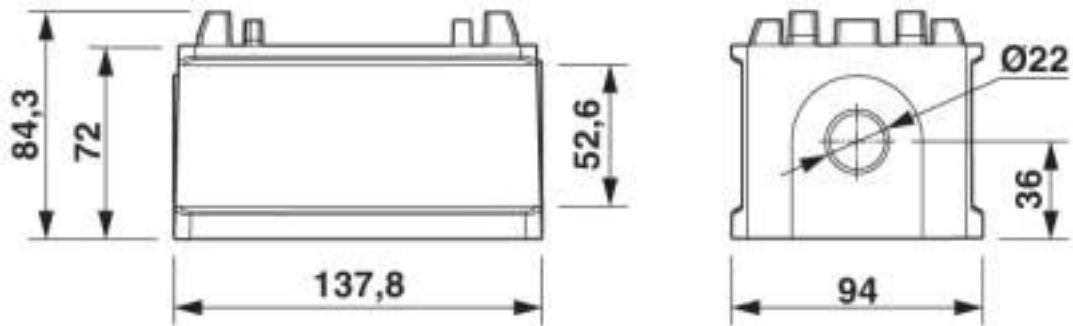

Dimensional drawing

Dimensional drawing

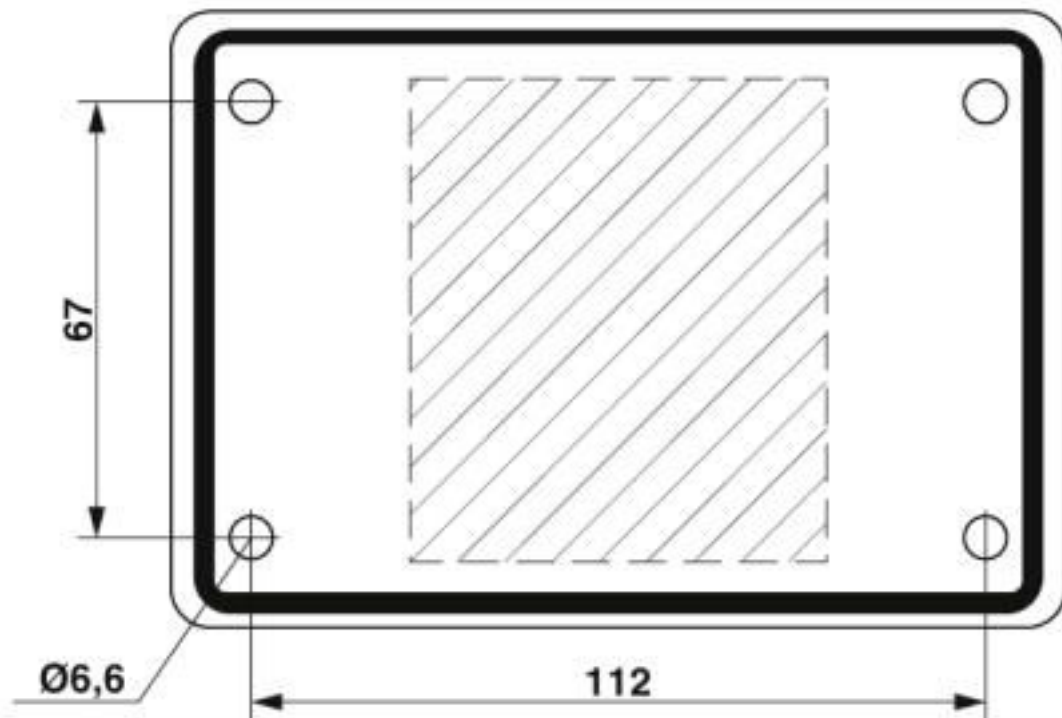

Fixing holes

Housing - HC-B 32-AFS-72-EEE - 1580525

Classifications

eCl@ss

eCl@ss 4.0	272607xx
eCl@ss 4.1	27260701
eCl@ss 5.0	27371205
eCl@ss 5.1	27261200
eCl@ss 6.0	27261200
eCl@ss 7.0	27440202
eCl@ss 8.0	27440202
eCl@ss 9.0	27440202

ETIM

ETIM 3.0	EC000437
ETIM 4.0	EC000437
ETIM 5.0	EC000437
ETIM 6.0	EC000437

UNSPSC

UNSPSC 6.01	31261501
UNSPSC 7.0901	31261501
UNSPSC 11	31261501
UNSPSC 12.01	31261502
UNSPSC 13.2	31261501
UNSPSC 19.0	31261501

Accessories

Accessories

Screwdriver tools

Screwdriver - SF-BIT-HEXB 5-89 - 1208911



Screw bit, hexagonal with ball head, E6.3-1/4" drive, size: Hex 5 x 89 mm, hardened, suitable for holder according to DIN 3126-F 6.3/ISO 1173

Screwdriver - SF-M BH - 1212070



Bit screwdriver, with 1/4" quick-action chuck, handle length 119 mm, 2-component handle, with non-slip grip, suitable for bits according to DIN 3126-C 6.3 and E 6.3/ISO 1173, magnetic

Phoenix Contact 2020 © - all rights reserved
<http://www.phoenixcontact.com>

PHOENIX CONTACT GmbH & Co. KG
Flachsmarktstr. 8
32825 Blomberg
Germany
Tel. +49 5235 300
Fax +49 5235 3 41200
<http://www.phoenixcontact.com>

Mouser Electronics

Authorized Distributor

Click to View Pricing, Inventory, Delivery & Lifecycle Information:

[Phoenix Contact:](#)

[1580525](#)