

Extension module - PSR-M-EM5-TTL2-SC - 1105014

Please be informed that the data shown in this PDF Document is generated from our Online Catalog. Please find the complete data in the user's documentation. Our General Terms of Use for Downloads are valid (<http://phoenixcontact.com/download>)



Safe extension module for monitoring zero-speed, speed, direction of rotation, monitoring of 2 axes, NPN/ PNP proximity switch, 2 x TTL encoder, TBUS interface, up to SILCL 3, Cat. 4/PL e, SIL 3, pluggable screw terminal block, TBUS connector included

Product Description

The configurable and individually scalable PSRmodular safety system is a flexible safety solution for monitoring your machine or system. The safe extension module is used to monitor downtimes, speed, and direction of rotation. The module is suitable for the connection of NPN/PNP proximity switches and TTL encoders.

Your advantages

- Economical safety solution with a high level of adaptability to individual requirements
- Fast startup, thanks to easy hardware and software configuration
- Machine downtime minimized with comprehensive, easy-to-understand diagnostics
- Low housing width of only 22.5mm
- Up to Cat. 4/PL e according to ISO 13849-1, SILCL 3 according to IEC 62061, SIL 3 according to IEC 61508
- Suitable for lift applications according to EN 81-20



Key Commercial Data

Packing unit	1 pc
GTIN	
GTIN	4055626975108

Technical data

Dimensions

Width	22.5 mm
Height	112.2 mm
Depth	114.5 mm

Ambient conditions

Ambient temperature (operation)	-10 °C ... 55 °C (observe derating)
Ambient temperature (storage/transport)	-20 °C ... 85 °C
Max. permissible relative humidity (operation)	95 % (non-condensing)

Extension module - PSR-M-EM5-TTL2-SC - 1105014

Technical data

Ambient conditions

Max. permissible humidity (storage/transport)	95 % (non-condensing)
Maximum altitude	≤ 2000 m (Above sea level)

Power supply

Designation	A1/A2
Rated control circuit supply voltage U_S	24 V DC -20 % / +20 % (provide external protection, typically 1 A)
Rated control supply current I_S	typ. 50 mA
Current consumption	max. 175 mA (with full load)
Power consumption at U_S	typ. 1.2 W
Inrush current	20 A ($\Delta t = 500 \mu s$ at U_S)
Filter time	typ. 20 ms (at A1 in the event of voltage dips at U_S)
Protective circuit	Serial protection against polarity reversal
	Suppressor diode

Measuring inputs

Input name	Proximity switch inputs
Description of the input	NPN / PNP (3- or 4-wire)
Number of inputs	2
Precision	5 % (in reference to the parameterized limit value)
Current consumption	typ. 13 mA (NPN, at U_S)
	typ. -13 mA (PNP, at U_S)
	max. 17 mA (NPN, at 28.8 V DC)
	max. -15 mA (PNP, at 28.8 V DC)
Input voltage range "0" signal	0 V DC ... 5 V DC (NPN)
Input voltage range "1" signal	16 V DC ... 28.8 V DC (NPN)
Input current range "0" signal	< 2 mA (NPN)
Max. permissible overall conductor resistance	150 Ω
Limit frequency	max. 5 kHz
Protective circuit	Suppressor diode
Input name	Encoder inputs
Description of the input	TTL
Number of inputs	2
Precision	5 % (in reference to the parameterized limit value)
Current consumption	typ. 30 mA (5 V supply connection)
Max. permissible overall conductor resistance	150 Ω
Limit frequency	max. 500 kHz
Input impedance	120 Ω (per trace)
TTL signal form	2.5 V ... 5 V (Duty factor trace A, B: 50% \pm 15%, phase shift trace A, B: 90° \pm 40°, supply: 5 V \pm 0.1 V)

Digital outputs

Output name	Proximity switch supply
-------------	-------------------------

Extension module - PSR-M-EM5-TTL2-SC - 1105014

Technical data

Digital outputs

	24V/0V
Nominal output voltage range	16.7 V DC ... 26.3 V DC (U _S - 2,5 V)
Short-circuit protection	no

Times

Response time	see user manual
Restart time	min. 5 s (Boot time)
	max. 10 s (Boot time)

General

Nominal operating mode	100% operating factor
Net weight	199.5 g
Mounting position	vertical or horizontal
Mounting type	DIN rail mounting
Assembly instructions	Observe derating
Degree of protection	IP20
Min. degree of protection of inst. location	IP54
Protection class	III (EN 50178)
Housing material	Polyamide PA non-reinforced
Housing color	yellow
Operating voltage display	1 x green LED
Status display	1 x LED (green), 2 x LED (orange)
	6 x LED (yellow)
Indication	2 x LED (red)

Connection data

Connection method	Screw connection
pluggable	Yes
Conductor cross section solid	0.2 mm ² ... 2.5 mm ²
Conductor cross section flexible	0.2 mm ² ... 2.5 mm ²
Conductor cross-section AWG	24 ... 12
Stripping length	7 mm
Screw thread	M3
Torque	0.5 Nm ... 0.6 Nm

Safety-related characteristic data

Designation	IEC 61508 - High demand
Safety Integrity Level (SIL)	3
Designation	EN ISO 13849-1
Performance level (PL)	e
Category	4
Designation	EN 62061
Safety Integrity Level Claim Limit (SIL CL)	3

Extension module - PSR-M-EM5-TTL2-SC - 1105014

Technical data

Standards and Regulations

Designation	Air clearances and creepage distances between the power circuits
Standards/regulations	EN 50178
Rated insulation voltage	250 V AC
Rated surge voltage/insulation	Basic insulation 4 kV between 24 V power supply and I/Os to the housing
Degree of pollution	2
Overvoltage category	III
Shock	10g for $\Delta t = 16$ ms (continuous shock, 1000 shocks in each space direction)
Vibration (operation)	10 Hz ... 150 Hz, 2g
Conformance	CE-compliant

Environmental Product Compliance

China RoHS	Environmentally friendly use period: unlimited = EFUP-e
	No hazardous substances above threshold values

Drawings

Application drawing

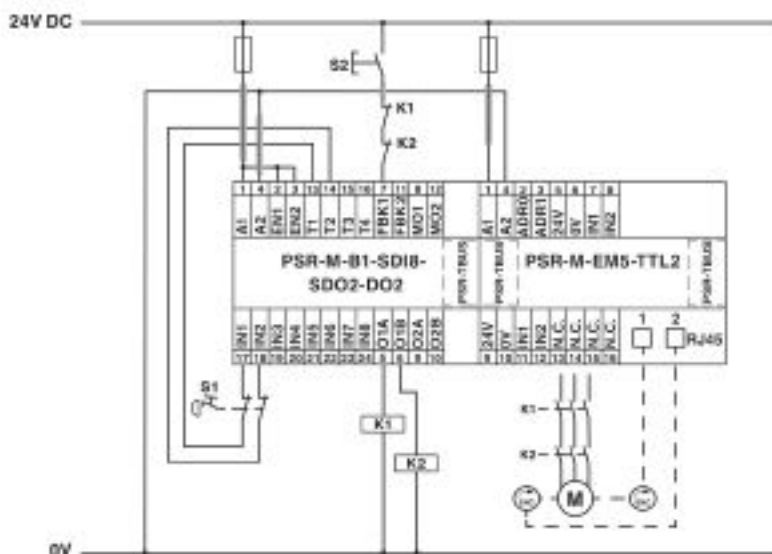

Extension module - PSR-M-EM5-TTL2-SC - 1105014

Block diagram

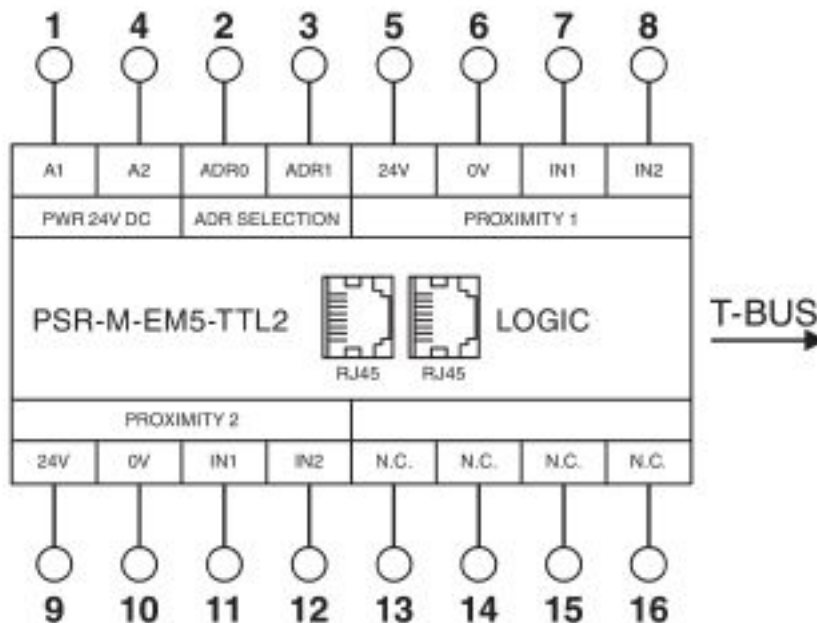

Classifications

eCl@ss

eCl@ss 10.0.1	27371819
eCl@ss 8.0	27371819
eCl@ss 9.0	27371819

ETIM

ETIM 5.0	EC001449
----------	----------

Approvals

Approvals

Approvals

UL Listed / cUL Listed / cULus Listed

Ex Approvals

Approval details

Extension module - PSR-M-EM5-TTL2-SC - 1105014

Approvals

UL Listed		http://database.ul.com/cgi-bin/XYV/template/LISEXT/1FRAME/index.htm	FILE E 238705
-----------	--	---	---------------

cUL Listed		http://database.ul.com/cgi-bin/XYV/template/LISEXT/1FRAME/index.htm	FILE E 238705
------------	--	---	---------------

cULus Listed			
--------------	--	--	--

Accessories

Accessories

Coding element

Coding profile - CP-MSTB - 1734634

Coding profile, is inserted into the slot on the plug or inverted header, red insulating material



Coding section - CR-MSTB - 1734401

Coding section, inserted into the recess in the header or the inverted plug, red insulating material



Phoenix Contact 2020 © - all rights reserved
<http://www.phoenixcontact.com>

PHOENIX CONTACT GmbH & Co. KG
Flachsmarktstr. 8
32825 Blomberg
Germany
Tel. +49 5235 300
Fax +49 5235 3 41200
<http://www.phoenixcontact.com>

Mouser Electronics

Authorized Distributor

Click to View Pricing, Inventory, Delivery & Lifecycle Information:

[Phoenix Contact:](#)

[1105014](#)