

Housing - HC-STA-B16-SHWS-2SSM32-ELC-AL - 1082587

Please be informed that the data shown in this PDF Document is generated from our Online Catalog. Please find the complete data in the user's documentation. Our General Terms of Use for Downloads are valid (<http://phoenixcontact.com/download>)



Box mounting bases B16, with single locking latch, material: Die-cast aluminum, salt water resistant, cable outlets: 2, lateral, height: 84.7 mm, cable gland: none, support sleeve: no, 2x M32, Standard

Your advantages

- ☑ good shielding in the event of electromagnetic interference



Key Commercial Data

Packing unit	1 pc
GTIN	
GTIN	4055626816241

Technical data

Dimensions

Height	84.7 mm
Width	57 mm
Length	117.5 mm

Ambient conditions

Degree of protection (IP)	IP66
	IP67
Degree of protection (NEMA)	4 (UL 50e)
	4X (UL 50e)
	12 (UL 50e)
Ambient temperature (operation)	-40 °C ... 125 °C

General

Note	For contact inserts HC-B16, BB32, D40, DD72, HS6, HV6, M, K
Size	B16
Housing type	Box mounting bases

Housing - HC-STA-B16-SHWS-2SSM32-ELC-AL - 1082587

Technical data

General

Color	gray aluminum
Locking type	with single locking latch
No. of cable outlets	2
Cable outlet	lateral
Screw connection	none
Type of the screw connection	2x M32
Housing material	Die-cast aluminum, salt water resistant
Housing surface material	uncoated
Seal material	NBR, conductive
Material lock	PA
Flammability rating according to UL 94	V0 (Interlock)
Assembly instructions	One opening is sealed with a plastic filler plug and can be opened using a screwdriver.

Drawings

Dimensional drawing

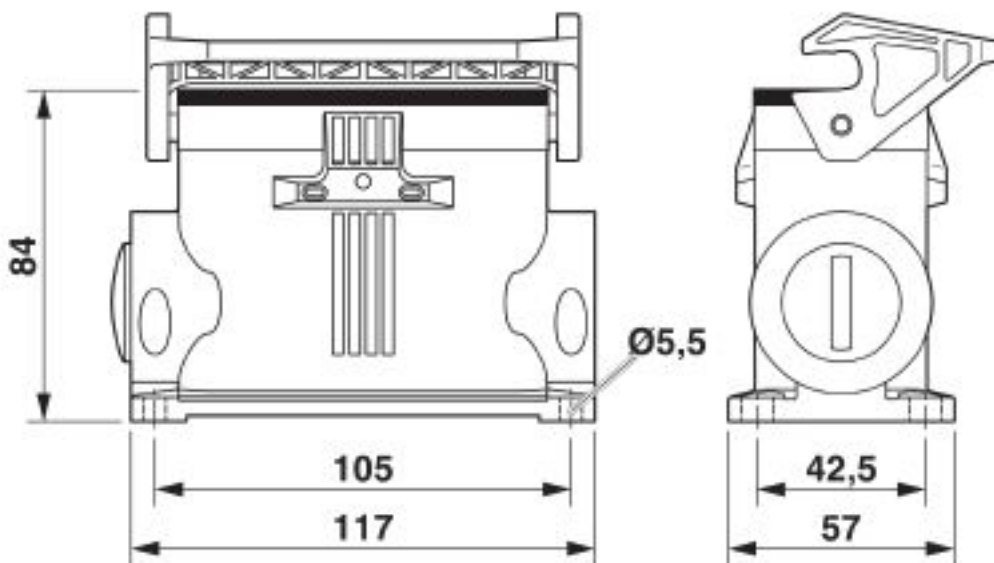

Dimensional drawing

Classifications

eCl@ss

eCl@ss 10.0.1	27440202
eCl@ss 5.1	27261200
eCl@ss 6.0	27261200

Housing - HC-STA-B16-SHWS-2SSM32-ELC-AL - 1082587

Classifications

eCl@ss

eCl@ss 7.0	27440202
eCl@ss 8.0	27440202
eCl@ss 9.0	27440202

ETIM

ETIM 5.0	EC000437
ETIM 6.0	EC000437
ETIM 7.0	EC000437

UNSPSC

UNSPSC 13.2	31261501
UNSPSC 18.0	31261501
UNSPSC 19.0	31261501
UNSPSC 20.0	31261501
UNSPSC 21.0	31261501

Accessories

Accessories

Full screw connection

Cable gland - G-INS-M32-M68N-NNES-S - 1411166



Cable gland, cable gland material: Nickel-plated brass, external cable diameter 15 mm ... 21 mm, shielding: no, connecting thread: M32 x 1.5, color: silver, with O-ring

Cable gland - G-INSEC-M32-M68N-NCRS-S - 1411191



Cable gland, cable gland material: Nickel-plated brass, external cable diameter 14 mm ... 21 mm, shielding: yes, connecting thread: M32 x 1.5, color: silver, with O-ring

Housing latches

Replacement part - HC-STA-B16-SL-PLBK - 1412284



Single locking latch for B16 housing, HC-EVO....AL and HC-STA....AL

Housing - HC-STA-B16-SHWS-2SSM32-ELC-AL - 1082587

Accessories

Seal

Profile gasket - HC-B16-SP-CBK - 1411480



Profile gasket for HEAVYCON EVO supporting base element type B16, conductive

Phoenix Contact 2020 © - all rights reserved
<http://www.phoenixcontact.com>

PHOENIX CONTACT GmbH & Co. KG
Flachsmarktstr. 8
32825 Blomberg
Germany
Tel. +49 5235 300
Fax +49 5235 3 41200
<http://www.phoenixcontact.com>

Mouser Electronics

Authorized Distributor

Click to View Pricing, Inventory, Delivery & Lifecycle Information:

[Phoenix Contact:](#)

[1082587](#)