

Housing - HC-COM-HHFS-1SGM25-PL-BK - 1012581

Please be informed that the data shown in this PDF Document is generated from our Online Catalog. Please find the complete data in the user's documentation. Our General Terms of Use for Downloads are valid (<http://phoenixcontact.com/download>)



Sleeve housing COM, for single locking latch, material: PA, cable outlets: 1, lateral, height: 84 mm, cable gland: with, support sleeve: no, 1x M25, Standard



COMPLIES WITH

Key Commercial Data

Packing unit	1 pc
GTIN	 4 0 5 5 6 2 6 4 9 0 4 0 3
GTIN	4055626490403

Technical data

Dimensions

Height	84 mm
Width	39 mm
Length	48.8 mm
External cable diameter	10 mm ... 16 mm

Ambient conditions

Degree of protection (IP)	IP66
Ambient temperature (operation)	-40 °C ... 125 °C

General

Size	COM
Housing type	Sleeve housing
Color	black
Locking type	for single locking latch
No. of cable outlets	1
Cable outlet	lateral
Screw connection	with
Type of the screw connection	1x M25
Housing material	PA

Housing - HC-COM-HHFS-1SGM25-PL-BK - 1012581

Technical data

General

Flammability rating according to UL 94	V0 (Housing)
--	--------------

Environmental Product Compliance

REACH SVHC	Lead 7439-92-1
China RoHS	Environmentally Friendly Use Period = 50 years
	For details about hazardous substances go to tab "Downloads", Category "Manufacturer's declaration"

Drawings

Dimensional drawing

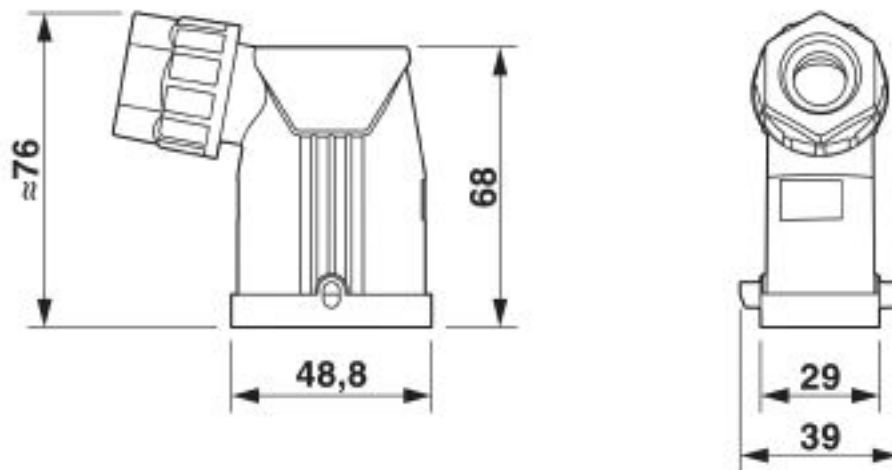

Classifications

eCl@ss

eCl@ss 10.0.1	27440202
eCl@ss 4.0	27140816
eCl@ss 4.1	27140816
eCl@ss 5.0	27143424
eCl@ss 5.1	27261200
eCl@ss 6.0	27261200
eCl@ss 7.0	27440202
eCl@ss 8.0	27440202
eCl@ss 9.0	27440202

ETIM

ETIM 4.0	EC000437
ETIM 5.0	EC000437
ETIM 6.0	EC000437

Housing - HC-COM-HHFS-1SGM25-PL-BK - 1012581

Classifications

ETIM

ETIM 7.0	EC000437
----------	----------

UNSPSC

UNSPSC 6.01	31261502
UNSPSC 7.0901	31261502
UNSPSC 11	31261502
UNSPSC 12.01	31261502
UNSPSC 13.2	31261501
UNSPSC 18.0	31261501
UNSPSC 19.0	31261501
UNSPSC 20.0	31261501
UNSPSC 21.0	31261501

Phoenix Contact 2020 © - all rights reserved
<http://www.phoenixcontact.com>

PHOENIX CONTACT GmbH & Co. KG
Flachsmarktstr. 8
32825 Blomberg
Germany
Tel. +49 5235 300
Fax +49 5235 3 41200
<http://www.phoenixcontact.com>

Mouser Electronics

Authorized Distributor

Click to View Pricing, Inventory, Delivery & Lifecycle Information:

[Phoenix Contact:](#)

[1012581](#)