

Bus system cable - SAC-4P-MINMS/ 2,0-961/MINFRVAL - 1434413

Please be informed that the data shown in this PDF Document is generated from our Online Catalog. Please find the complete data in the user's documentation. Our General Terms of Use for Downloads are valid (<http://phoenixcontact.com/download>)



Bus system cable, FOUNDATION Fieldbus (31.25 kbps), 3-position, PVC, blue RAL 5015, shielded, Plug straight 7/8"-16UNF, coding: A, on Socket angled 7/8"-16UNF, coding: A, cable length: 2 m



Key Commercial Data

Packing unit	1 pc
GTIN	
GTIN	4046356456005

Technical data

Dimensions

Length of cable	2 m
-----------------	-----

Ambient conditions

Ambient temperature (operation)	-40 °C ... 105 °C (Plug / socket)
Degree of protection	IP67

General

Note	For applications in circuits of intrinsic safety protection type "i". Electrical values following EN 60079-14.
Rated current at 40°C	5.2 A
Rated voltage	300 V
Number of positions	3
Insulation resistance	≥ 10 MΩ
Coding	A - standard
Signal type/category	FOUNDATION Fieldbus, 31.25 kbps
Status display	No
Degree of pollution	2
Torque	0.8 Nm (7/8" connectors)

Material

Bus system cable - SAC-4P-MINMS/ 2,0-961/MINFRVAL - 1434413

Technical data

Material

Contact material	CuZn
Contact surface material	Au
Contact carrier material	PA66
Material of grip body	TPU
Material, knurls	Stainless steel
Sealing material	TPU

Pin assignment

Contact Color (signal designation) Contact (optional)	1 (Plug) BU (DATA-) 1 (Socket)
	2 (Plug) OG (DATA+) 2 (Socket)
	3 (Plug) SR (shield) 3 (Socket)

Cable

Cable type	Fieldbus FOUNDATION/PROFIBUS PA, blue
Cable type (abbreviation)	961
Cable structure	2xAWG18/7 + 1xAWG20/7
Conductor cross section	2x 0.75 mm ² (Signal line)
	1x 0.5 mm ² (Drain wire)
AWG signal line	18
Conductor structure signal line	7x 0.40 mm
Core diameter including insulation	2.24 mm ±0.05 mm
Thickness, insulation	0.5 mm
Wire colors	Blue, orange
Twisted pairs	2 cores to the pair
Overall twist	One pair with one drain wire and fillers for core
Shielding	Plastic-coated aluminum foil with a drain wire
Optical shield covering	100 %
External sheath, color	blue RAL 5015
Outer sheath thickness	1 mm
External cable diameter D	7.5 mm ±0.25 mm
Smallest bending radius, fixed installation	75 mm
Cable weight	56.552 kg/km
Tensile strength GRP	260 N
Outer sheath, material	PVC
Material conductor insulation	PO (Signal line)
Conductor material	Tin-plated Cu litz wires
Conductor resistance	≤ 19.35 Ω/km (Signal line)
	26 Ω/km (shield)
Working capacitance	78 nF (at 1 kHz)
Cable capacity	147 pF/m (at 1 kHz, core/shield)
	≤ 3.94 pF/m (capacitance unbalance)
Signal speed	0.66 c

Bus system cable - SAC-4P-MINMS/ 2,0-961/MINFRVAL - 1434413

Technical data

Cable

Shield attenuation	3 dB/km (at 39 kHz)
Cable impedance	100 Ω ±20 % (At 31.25 kHz)
Conductor inductance	0.6233 μH/m
Nominal voltage, cable	300 V
Special properties	UL standards PLTC-ER and ITC
Flame resistance	UL 1685 (CSA FT 4)
	UL 1685 (vertical tray)
	UL 1666 (riser)
Ambient temperature (operation)	-40 °C ... 105 °C (cable, fixed installation)

Environmental Product Compliance

China RoHS	Environmentally Friendly Use Period = 50 years
	For details about hazardous substances go to tab "Downloads", Category "Manufacturer's declaration"

Drawings

Dimensional drawing

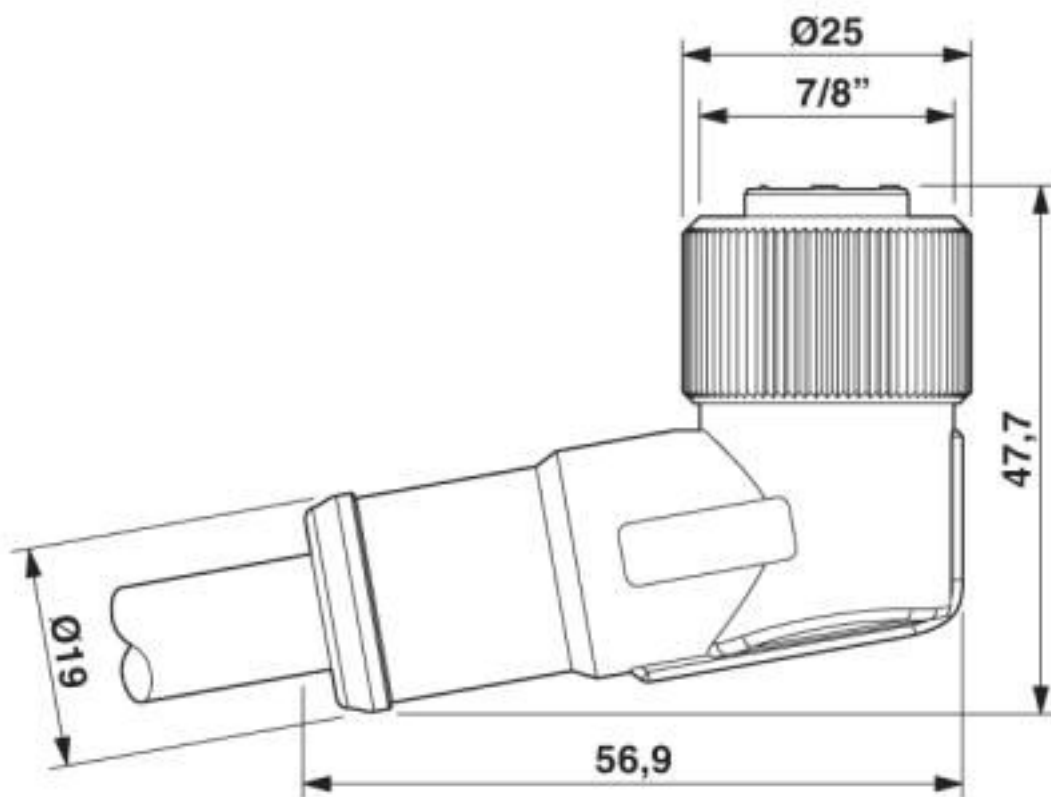

7/8"-16UNF socket, angled

Bus system cable - SAC-4P-MINMS/ 2,0-961/MINFRVAL - 1434413

Dimensional drawing

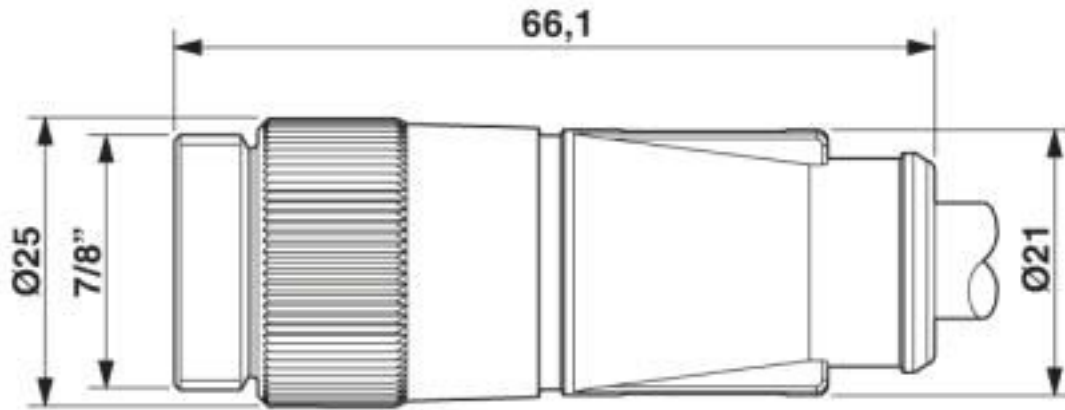

7/8"-16UNF plug, straight

Circuit diagram

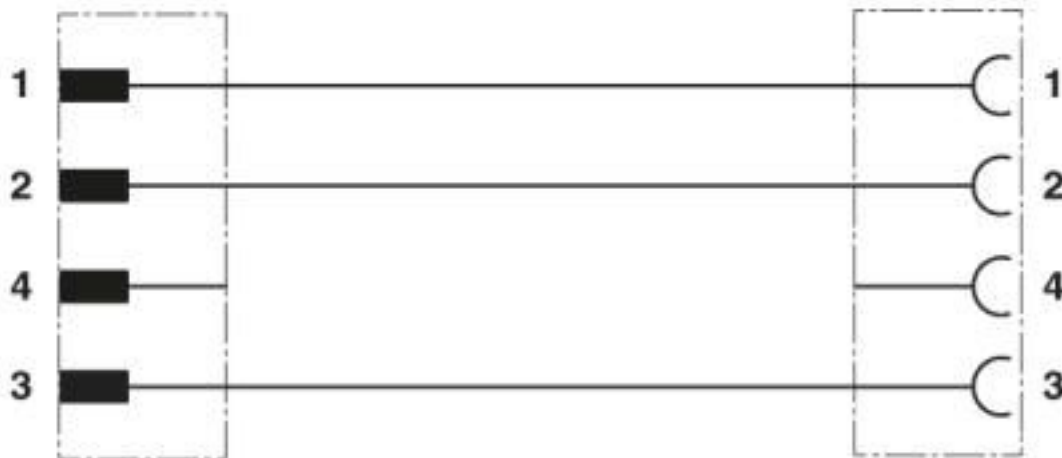

Contact assignment of the 7/8" plug

Bus system cable - SAC-4P-MINMS/ 2,0-961/MINFRVAL - 1434413

Schematic diagram

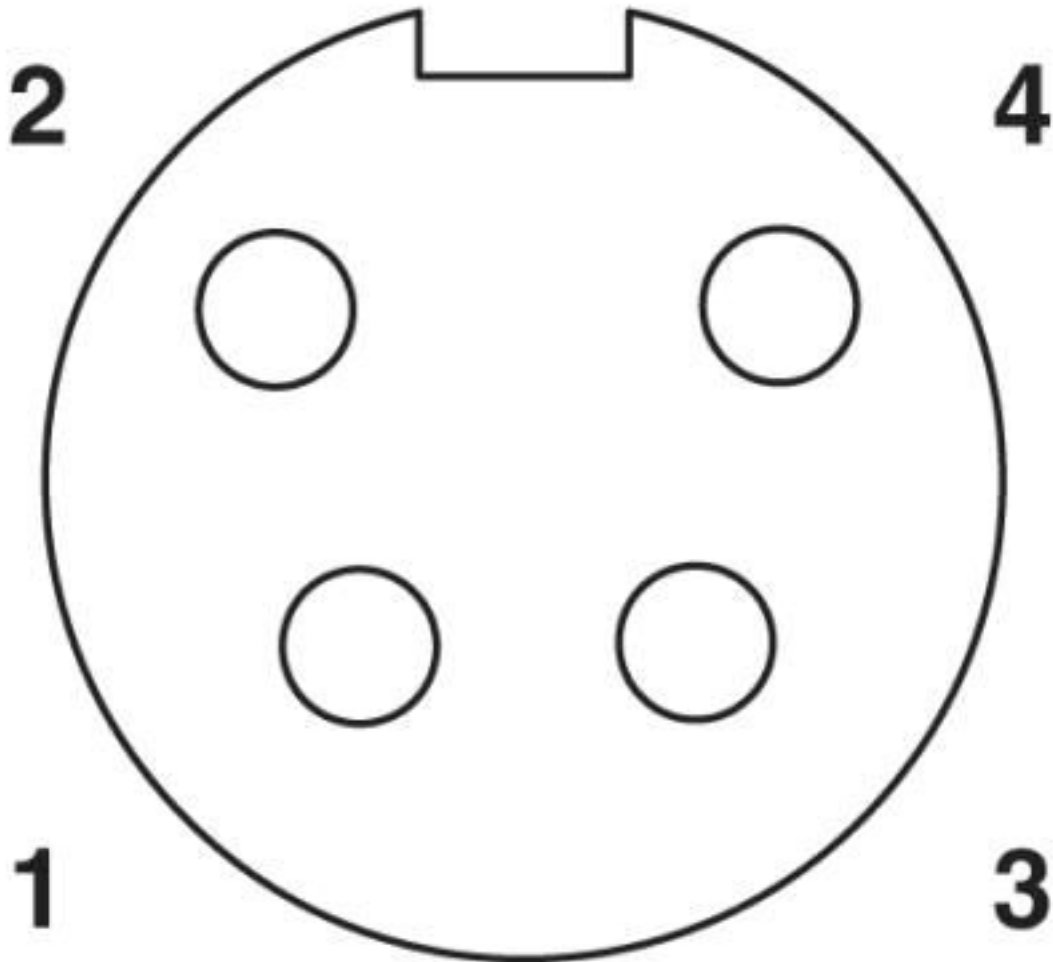

Pin assignment, socket, 7/8"-16UNF, 4-pos., view of female side

Bus system cable - SAC-4P-MINMS/ 2,0-961/MINFRVAL - 1434413

Schematic diagram

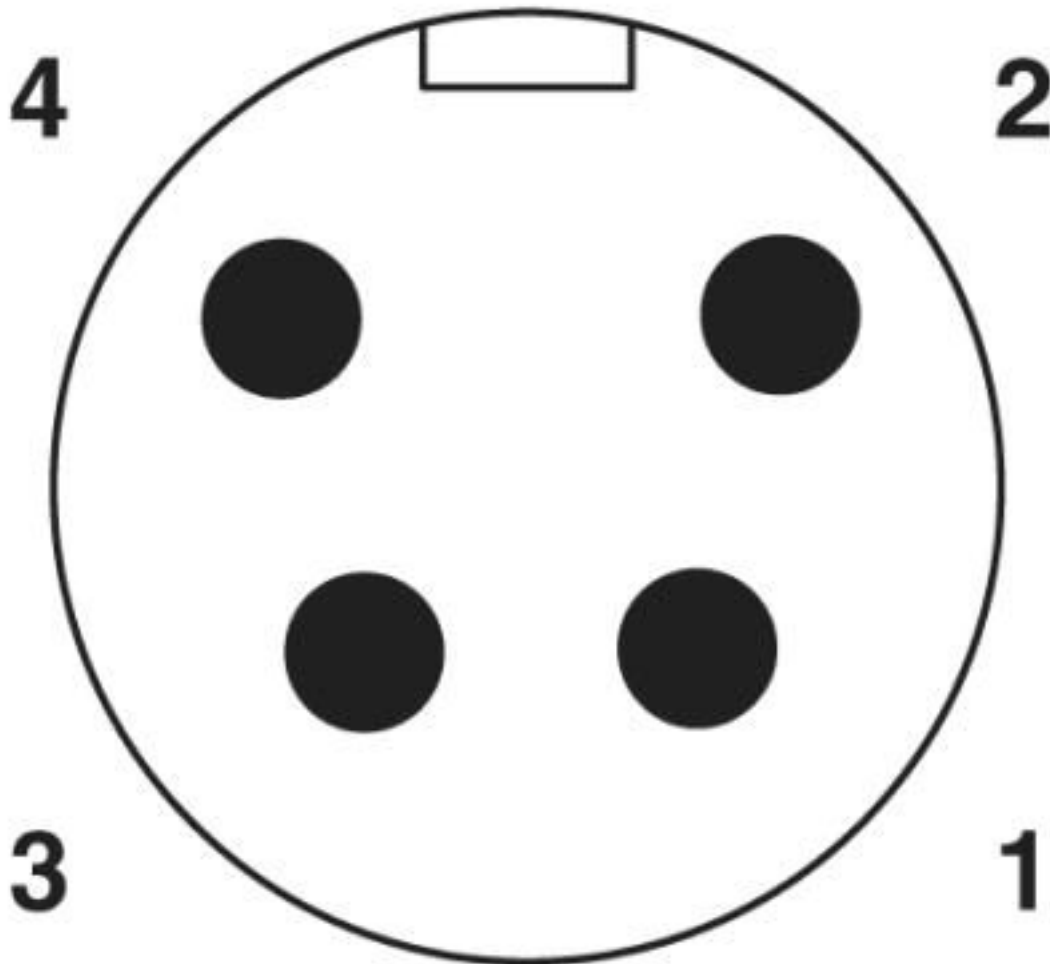

Pin assignment, plug, 7/8"-16UNF, 4-pos., view of male side

Bus system cable - SAC-4P-MINMS/ 2,0-961/MINFRVAL - 1434413

Cable cross section

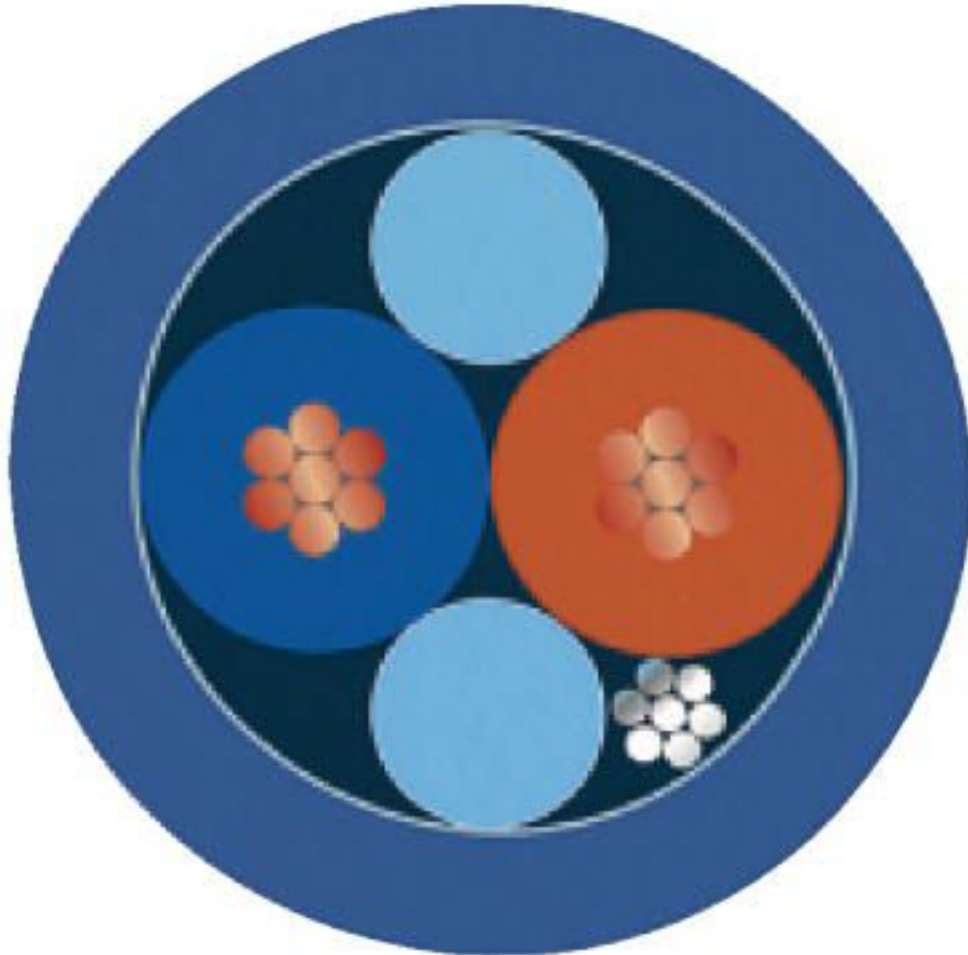

Fieldbus FOUNDATION/PROFIBUS PA, blue [961]

Classifications

eCl@ss

eCl@ss 4.0	27060306
eCl@ss 4.1	27060306
eCl@ss 5.0	27061801
eCl@ss 5.1	27061800
eCl@ss 6.0	27279200
eCl@ss 7.0	27279218
eCl@ss 8.0	27279218
eCl@ss 9.0	27060311

Bus system cable - SAC-4P-MINMS/ 2,0-961/MINFRVAL - 1434413

Classifications

ETIM

ETIM 3.0	EC001855
ETIM 4.0	EC001855
ETIM 5.0	EC001855
ETIM 6.0	EC001855

UNSPSC

UNSPSC 6.01	31251501
UNSPSC 7.0901	31251501
UNSPSC 11	31251501
UNSPSC 12.01	31251501
UNSPSC 13.2	31251501
UNSPSC 19.0	31251501

Phoenix Contact 2020 © - all rights reserved
<http://www.phoenixcontact.com>

PHOENIX CONTACT GmbH & Co. KG
Flachsmarktstr. 8
32825 Blomberg
Germany
Tel. +49 5235 300
Fax +49 5235 3 41200
<http://www.phoenixcontact.com>

Mouser Electronics

Authorized Distributor

Click to View Pricing, Inventory, Delivery & Lifecycle Information:

[Phoenix Contact:](#)

[1434413](#)