

Housing - HC-STA-B48-SHWSC-2SSP29-EMC-AL - 1424869

Please be informed that the data shown in this PDF Document is generated from our Online Catalog. Please find the complete data in the user's documentation. Our General Terms of Use for Downloads are valid (<http://phoenixcontact.com/download>)



Box mounting bases B48, with single locking latch, material: Die-cast aluminum, salt water resistant, protective cover material: PA, cable outlets: 2, lateral, height: 99 mm, cable gland: none, support sleeve: yes, 2x Pg29, protective cover: yes, Standard

Your advantages

- ✔ good shielding in the event of electromagnetic interference



Key Commercial Data

Packing unit	1 pc
GTIN	
GTIN	4055626382746

Technical data

Dimensions

Height	99 mm
Width	120 mm
Length	132 mm

Ambient conditions

Degree of protection (IP)	IP66 (with locked protective cover)
	IP67 (when plugged in)
Ambient temperature (operation)	-40 °C ... 125 °C

General

Size	B48
Housing type	Box mounting bases
Color	gray aluminum
Locking type	with single locking latch
No. of cable outlets	2
Cable outlet	lateral

Housing - HC-STA-B48-SHWSC-2SSP29-EMC-AL - 1424869

Technical data

General

Screw connection	none
Type of the screw connection	2x Pg29
Protective cover	yes
Housing material	Die-cast aluminum, salt water resistant
Housing surface material	uncoated
Seal material	NBR, conductive
Material lock	PA
Material, protective cover	PA
Flammability rating according to UL 94	V0 (Interlock)
	V0 (Protective cover)
Assembly instructions	One opening is sealed with a plastic filler plug and can be opened using a screwdriver.

Environmental Product Compliance

China RoHS	Environmentally Friendly Use Period = 50 years
	For details about hazardous substances go to tab "Downloads", Category "Manufacturer's declaration"

Drawings

Dimensional drawing

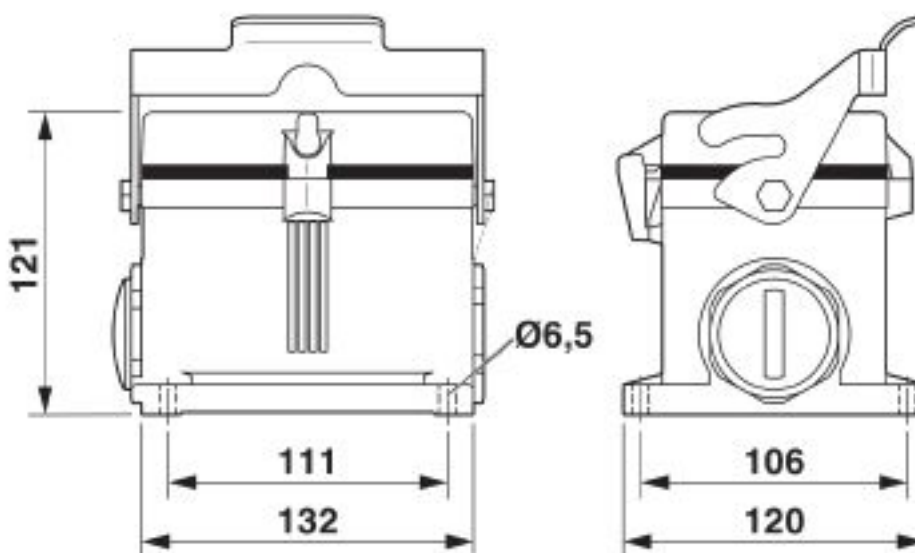

Dimensional drawing

Housing - HC-STA-B48-SHWSC-2SSP29-EMC-AL - 1424869

Classifications

eCl@ss

eCl@ss 10.0.1	27440202
eCl@ss 5.1	27261200
eCl@ss 6.0	27261200
eCl@ss 7.0	27440202
eCl@ss 8.0	27440202
eCl@ss 9.0	27440202

ETIM

ETIM 6.0	EC000437
ETIM 7.0	EC000437

Approvals

Approvals

Approvals

DNV GL

Ex Approvals

Approval details

DNV GL		https://approvalfinder.dnvgl.com/	TAE000037S
--------	---	---	------------

Phoenix Contact 2020 © - all rights reserved
<http://www.phoenixcontact.com>

PHOENIX CONTACT GmbH & Co. KG
Flachsmarktstr. 8
32825 Blomberg
Germany
Tel. +49 5235 300
Fax +49 5235 3 41200
<http://www.phoenixcontact.com>

Mouser Electronics

Authorized Distributor

Click to View Pricing, Inventory, Delivery & Lifecycle Information:

[Phoenix Contact:](#)

[1424869](#)