

Cable gland - G-INS-M20-M68N-SNES-S - 1424543

Please be informed that the data shown in this PDF Document is generated from our Online Catalog. Please find the complete data in the user's documentation. Our General Terms of Use for Downloads are valid (<http://phoenixcontact.com/download>)



Cable gland, cable gland material: Stainless steel 1.4305, external cable diameter 6 mm ... 12 mm, shielding: no, connecting thread: M20 x 1.5, color: silver, with O-ring

Key Commercial Data

Packing unit	1 pc
GTIN	
GTIN	4055626374482

Technical data

Dimensions

Length	33 mm
Wrench size, union nut	22 mm
Wrench size, support	22 mm
Hexagon angular dimension	24.5 mm
Length of the connecting thread	8 mm
Feed-through hole diameter	20.1 mm ... 20.3 mm
External cable diameter	6 mm ... 12 mm
	10 mm ... 12 mm (for UL 514 B)

Ambient conditions

Degree of protection (IP)	IP68 (5 bar, 30 min.)
	IP66
	IP69
Ambient temperature (operation)	-40 °C ... 100 °C (static)

General

No. of conductors	1
Cable gland material	Stainless steel 1.4305
Material, insert	Polyamide 6

Cable gland - G-INS-M20-M68N-SNES-S - 1424543

Technical data

General

Cable seal material	CR
Sealing material	Perbunan (O-ring)
Shielded	no
Thread type on connection side	M20 x 1.5
Torque	8 Nm (Union nut)
	8 Nm (Support sleeve)
	6 Nm (for UL514 B: union nut)
Color	silver
Impact category	2
Execution of the strain relief	A
Assembly instructions	1) Mount screw connection support in the housing using the correct torque 2) Insert cable 3) Tighten union nut using the correct torque
Manufacturer	BIMED
Manufacturer Designation	BMSC-02

Environmental Product Compliance

China RoHS	Environmentally Friendly Use Period = 50 years
	For details about hazardous substances go to tab "Downloads", Category "Manufacturer's declaration"

Drawings

Cable gland - G-INS-M20-M68N-SNES-S - 1424543

Dimensional drawing

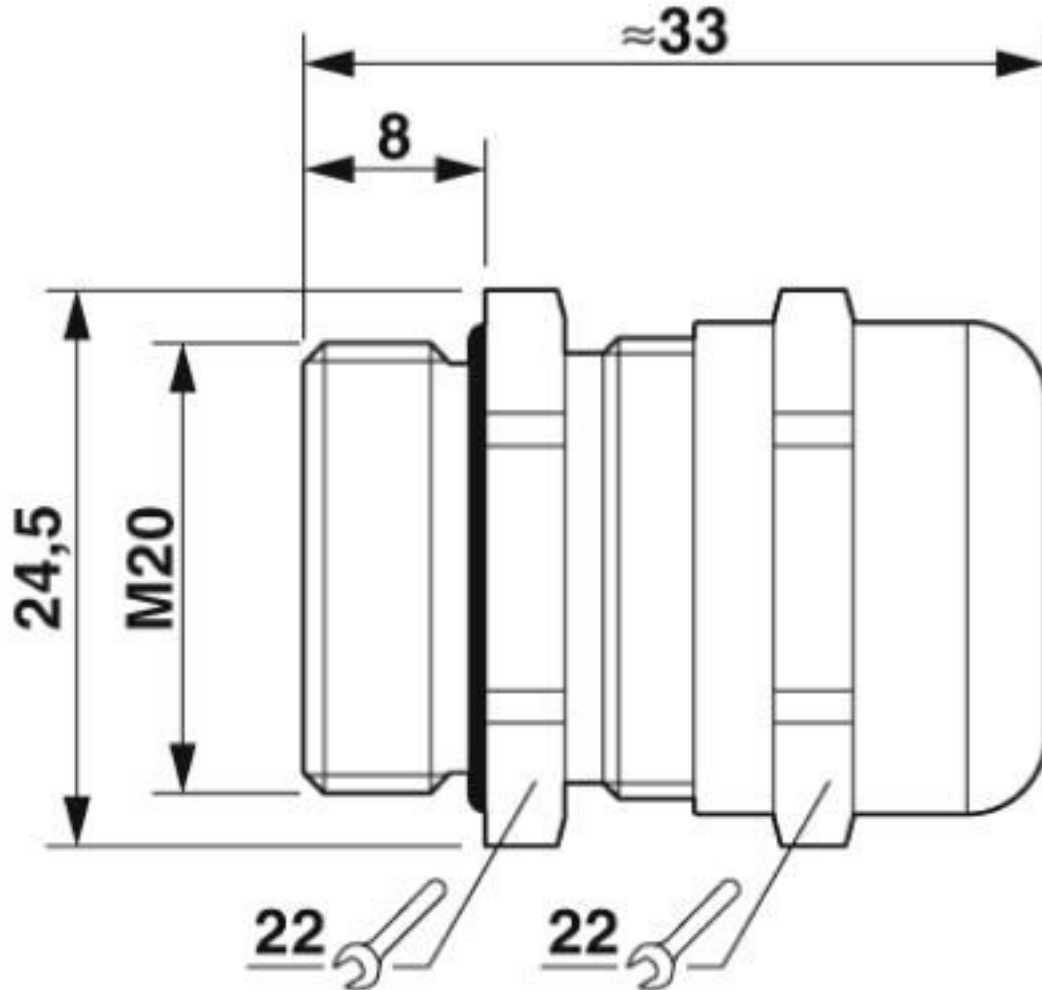

Dimensional drawing

Classifications

eCl@ss

eCl@ss 10.0.1	27144432
eCl@ss 4.0	27141200
eCl@ss 4.1	27141200
eCl@ss 5.0	27149100
eCl@ss 5.1	27149109
eCl@ss 6.0	27149100
eCl@ss 7.0	27149109
eCl@ss 8.0	27149109
eCl@ss 9.0	27144432

Cable gland - G-INS-M20-M68N-SNES-S - 1424543

Classifications

ETIM

ETIM 5.0	EC000441
ETIM 6.0	EC000441
ETIM 7.0	EC000441

Approvals

Approvals

Approvals

UL Listed / cUL Listed / cULus Listed

Ex Approvals

Approval details

UL Listed		http://database.ul.com/cgi-bin/XYV/template/LISEXT/1FRAME/index.htm	E199260
-----------	--	---	---------

cUL Listed		http://database.ul.com/cgi-bin/XYV/template/LISEXT/1FRAME/index.htm	E199260
------------	--	---	---------

cULus Listed			
--------------	--	--	--

Accessories

Accessories

Flat nut

Counter nut - A-INL-M20-S-S - 1411249



Counter nut, material: Stainless steel 1.4305, for threads M20 x 1.5, color: silver

Sealing plugs

Cable gland - G-INS-M20-M68N-SNES-S - 1424543

Accessories

Closing cap - SEALING PLUG 9X16 RD - 1400259



Closing cap, material: PA, color: red

Phoenix Contact 2020 © - all rights reserved
<http://www.phoenixcontact.com>

PHOENIX CONTACT GmbH & Co. KG
Flachsmarktstr. 8
32825 Blomberg
Germany
Tel. +49 5235 300
Fax +49 5235 3 41200
<http://www.phoenixcontact.com>

Mouser Electronics

Authorized Distributor

Click to View Pricing, Inventory, Delivery & Lifecycle Information:

[Phoenix Contact:](#)

[1424543](#)