

# Housing - HC-STA-B16-HLFS-BLANK-EL-AL - 1419905

Please be informed that the data shown in this PDF Document is generated from our Online Catalog. Please find the complete data in the user's documentation. Our General Terms of Use for Downloads are valid (<http://phoenixcontact.com/download>)



Sleeve housing B16, for single locking latch, material: Die-cast aluminum, salt water resistant, Variable, height: 60 mm, cable gland: none, support sleeve: no, Standard, Without thread opening for screw connection

## Product Description

Sleeve housing, without screw thread

## Your advantages

- good shielding in the event of electromagnetic interference



## Key Commercial Data

Packing unit	1 pc
GTIN	 4 055626 201283
GTIN	4055626201283

## Technical data

### Dimensions

Height	60 mm
Width	44 mm
Length	93.5 mm

### Ambient conditions

Degree of protection (IP)	IP66
	IP67
Degree of protection (NEMA)	4 (UL 50e)
	4X (UL 50e)
	12 (UL 50e)
Ambient temperature (operation)	-40 °C ... 125 °C

### General

Note	For contact inserts HC-B16, BB32, D40, DD72, HS6, HV6, M, K
------	---

# Housing - HC-STA-B16-HLFS-BLANK-EL-AL - 1419905

## Technical data

### General

Size	B16
Housing type	Sleeve housing
Color	gray aluminum
Locking type	for single locking latch
Cable outlet	Variable
Screw connection	none
Housing material	Die-cast aluminum, salt water resistant
Housing surface material	uncoated

### Environmental Product Compliance

China RoHS	Environmentally Friendly Use Period = 50 years
	For details about hazardous substances go to tab "Downloads", Category "Manufacturer's declaration"

## Drawings

Dimensional drawing

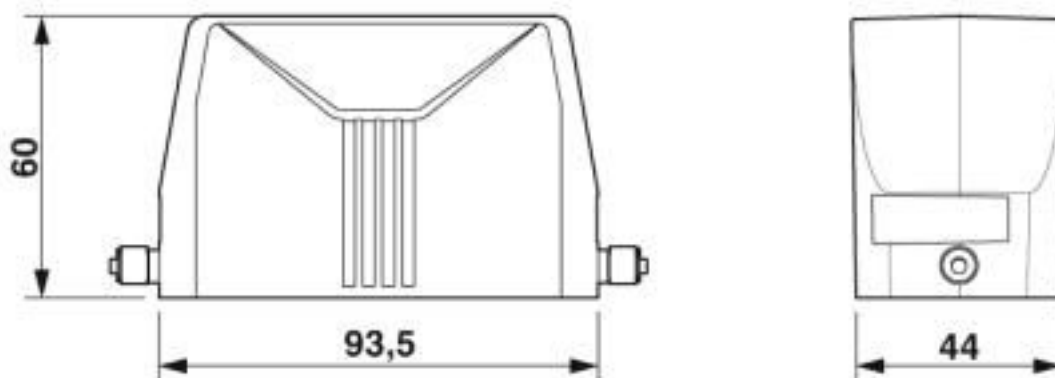

Dimensional drawing

## Classifications

### eCl@ss

eCl@ss 10.0.1	27440202
eCl@ss 5.1	27261200
eCl@ss 6.0	27261200
eCl@ss 7.0	27440202
eCl@ss 8.0	27440202
eCl@ss 9.0	27440202

### ETIM

ETIM 5.0	EC000437
----------	----------

# Housing - HC-STA-B16-HLFS-BLANK-EL-AL - 1419905

## Classifications

### ETIM

ETIM 6.0	EC000437
ETIM 7.0	EC000437

### UNSPSC

UNSPSC 13.2	31261501
UNSPSC 18.0	31261501
UNSPSC 19.0	31261501
UNSPSC 20.0	31261501
UNSPSC 21.0	31261501

## Approvals

### Approvals

Approvals

EAC / DNV GL

Ex Approvals

### Approval details

EAC		RU C- DE.AI30.B.01102
-----	--	--------------------------

DNV GL		<a href="https://approvalfinder.dnvgl.com/">https://approvalfinder.dnvgl.com/</a>	TAE000037S
--------	--	---	------------

## Accessories

### Accessories

Labeled device marker

Plastic label - US-EMLP (20X9) CUS - 0830085

Plastic label, can be ordered: by card, white, labeled according to customer specifications, mounting type: adhesive, lettering field size: 20 x 9 mm, Number of individual labels: 75



## Housing - HC-STA-B16-HLFS-BLANK-EL-AL - 1419905

### Accessories

#### Protective cover

Protective covers - HC-B16-HCLWS-PLR-BK - 1414636



Protective cover B16, with single locking latch, protective cover material: PA, height: 21.6 mm, seal: yes, diameter of retaining cord eyelet: 30 mm

---

Phoenix Contact 2020 © - all rights reserved  
<http://www.phoenixcontact.com>

PHOENIX CONTACT GmbH & Co. KG  
Flachsmarktstr. 8  
32825 Blomberg  
Germany  
Tel. +49 5235 300  
Fax +49 5235 3 41200  
<http://www.phoenixcontact.com>

# Mouser Electronics

Authorized Distributor

Click to View Pricing, Inventory, Delivery & Lifecycle Information:

[Phoenix Contact:](#)

[1419905](#)