

D-SUB sleeve housings - CUC-DST-GZNI-S/DSSC15 - 1419724

Please be informed that the data shown in this PDF Document is generated from our Online Catalog. Please find the complete data in the user's documentation. Our General Terms of Use for Downloads are valid (<http://phoenixcontact.com/download>)



D-SUB sleeve housings, degree of protection: IP20, material: Zinc die-cast, cable outlet: straight, size of housing: 2, color: Bare metallic

Your advantages

- ✓ Easy to mount thanks to pre-assembled locking screws
- ✓ Antimagnetic metal sleeve housing
- ✓ Well-suited for harsh industrial conditions thanks to its metal design
- ✓ Particularly suitable for D-SUB connectors with special contacts thanks to large interior



Key Commercial Data

Packing unit	1 pc
GTIN	 4 055626 188034
GTIN	4055626188034

Technical data

Mechanical characteristics

Minimum external conductor diameter	3 mm
Maximum external conductor diameter	8.5 mm
Cable outlet	straight
No. of cable outlets	1
Weight	58.9 g
Flammability rating according to UL 94	V0

Ambient conditions

Ambient temperature (operation)	-35 °C ... 100 °C
---------------------------------	-------------------

Material data

Housing material	Zinc die-cast
Housing surface material	Nickel-plated

D-SUB sleeve housings - CUC-DST-GZNI-S/DSSC15 - 1419724

Technical data

Material data

Width	30.8 mm
Height	12.5 mm
Depth	17.2 mm
Mounting type	Screw locking

Standards and Regulations

Flammability rating according to UL 94	V0
--	----

Environmental Product Compliance

REACH SVHC	Lead 7439-92-1
China RoHS	Environmentally friendly use period: unlimited = EFUP-e
	No hazardous substances above threshold values

Drawings

D-SUB sleeve housings - CUC-DST-GZNI-S/DSSC15 - 1419724

Schematic diagram

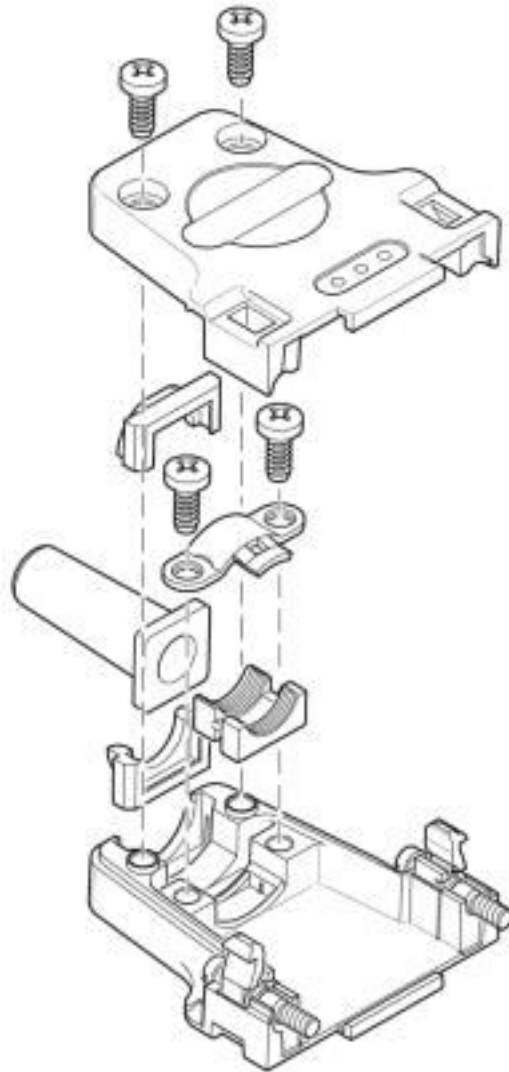

D-SUB sleeve housings - CUC-DST-GZNI-S/DSSC15 - 1419724

Dimensional drawing

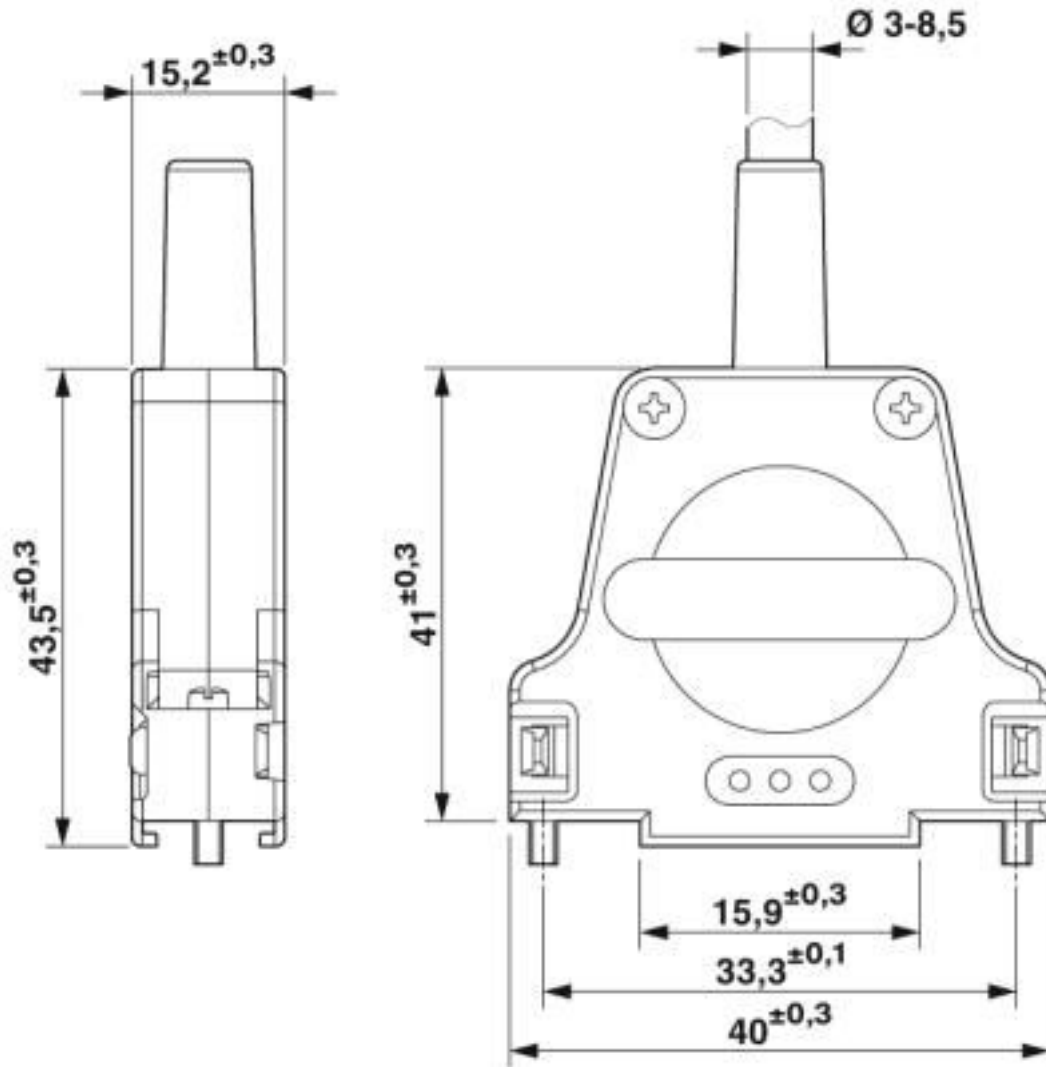

D-SUB sleeve housings

Classifications

eCl@ss

eCl@ss 10.0.1	27440302
eCl@ss 4.0	27260700
eCl@ss 4.1	27260700
eCl@ss 5.0	27260700
eCl@ss 5.1	27261200
eCl@ss 6.0	27261200
eCl@ss 7.0	27440302
eCl@ss 8.0	27440302

D-SUB sleeve housings - CUC-DST-GZNI-S/DSSC15 - 1419724

Classifications

eCl@ss

eCl@ss 9.0	27440302
------------	----------

ETIM

ETIM 2.0	EC000437
ETIM 3.0	EC000437
ETIM 4.0	EC000437
ETIM 5.0	EC001132
ETIM 6.0	EC001132
ETIM 7.0	EC001132

UNSPSC

UNSPSC 6.01	31261501
UNSPSC 7.0901	31261501
UNSPSC 11	31261501
UNSPSC 12.01	31261501
UNSPSC 13.2	39121522
UNSPSC 18.0	39121522
UNSPSC 19.0	39121522
UNSPSC 20.0	39121522
UNSPSC 21.0	39121522

Approvals

Approvals

Approvals

EAC

Ex Approvals

Approval details

EAC		B.01742
-----	--	---------

Accessories

Accessories

Female insert

D-SUB sleeve housings - CUC-DST-GZNI-S/DSSC15 - 1419724

Accessories

Contact insert - VS-15-BU-DSUB-EG - 1688887



D-SUB contact insert, shell size 2, with 15 signal contacts, type of contact socket, with solder cup, straight, fixing with a 3 mm hole, for panel mounting frame and sleeve housing VS-15-...

D-SUB contact insert - VS-15-BU-DSUB-HD-EG - 1655166



D-SUB contact insert, shell size 2, with 26 signal contacts, type of contact socket, with solder cup, straight, fixing with a 3 mm hole, for panel mounting frame and sleeve housing VS-15-...

D-SUB contact support - VS-15-BU-DSUB-CD-OG - 1688942



D-SUB contact carrier, shell size 2, for 15 signal contacts, type of contact socket, for crimp contacts, straight, fixing with a 3 mm hole, for panel mounting frame and sleeve housing VS-15-...

D-SUB contact support - VS-15-BU-DSUB-HD-CD-B - 1655182



D-SUB contact carrier, shell size 2, for 26 signal contacts, type of contact socket, for crimp contacts, straight, fixing with a 3 mm hole, for panel mounting frame and sleeve housing VS-15-...

D-SUB contact support - VS-15-BU-DSUB-3P - 1688214



D-SUB contact carrier, shell size 2, accommodation for three combined contacts, type of contact socket, straight, fixing with a 3 mm hole, for panel mounting frame and sleeve housing VS-15-...

D-SUB sleeve housings - CUC-DST-GZNI-S/DSSC15 - 1419724

Accessories

D-SUB combination contact insert - VS-15-BU-DSUB-2P-5S - 1688230

D-SUB contact insert, shell size 2, with five signal contacts with solder cup, straight, accommodation for two combined contacts, type of contact socket, fixing with a 3 mm hole, for panel mounting frame and sleeve housing VS-15-...



Male insert

Contact insert - VS-15-ST-DSUB-EG - 1688874

D-SUB contact insert, shell size 2, with 15 signal contacts, type of contact pin, with solder cup, straight, fixing with a 3 mm hole, for panel mounting frame and sleeve housing VS-15-...



D-SUB contact insert - VS-15-ST-DSUB-HD-EG - 1655179

D-SUB contact insert, shell size 2, with 26 signal contacts, type of contact pin, with solder cup, straight, fixing with a 3 mm hole, for panel mounting frame and sleeve housing VS-15-...



D-SUB contact support - VS-15-ST-DSUB-CD-OG - 1688939

D-SUB contact carrier, shell size 2, for 15 signal contacts, type of contact pin, for crimp contacts, straight, fixing with a 3 mm hole, for panel mounting frame and sleeve housing VS-15-...



D-SUB contact support - VS-15-ST-DSUB-HD-CD-B - 1655195

D-SUB contact carrier, shell size 2, for 26 signal contacts, type of contact pin, for crimp contacts, straight, fixing with a 3 mm hole, for panel mounting frame and sleeve housing VS-15-...



D-SUB sleeve housings - CUC-DST-GZNI-S/DSSC15 - 1419724

Accessories

D-SUB contact support - VS-15-ST-DSUB-3P - 1688201



D-SUB contact carrier, shell size 2, accommodation for three combined contacts, type of contact pin, straight, fixing with a 3 mm hole, for panel mounting frame and sleeve housing VS-15-...

D-SUB combination contact insert - VS-15-ST-DSUB-2P-5S - 1688227



D-SUB contact insert, shell size 2, with five signal contacts with solder cup, straight, accommodation for two combined contacts, type of contact pin, fixing with a 3 mm hole, for panel mounting frame and sleeve housing VS-15-...

Phoenix Contact 2020 © - all rights reserved
<http://www.phoenixcontact.com>

PHOENIX CONTACT GmbH & Co. KG
Flachsmarktstr. 8
32825 Blomberg
Germany
Tel. +49 5235 300
Fax +49 5235 3 41200
<http://www.phoenixcontact.com>

Mouser Electronics

Authorized Distributor

Click to View Pricing, Inventory, Delivery & Lifecycle Information:

[Phoenix Contact:](#)

[1419724](#)