

Housing - HC-STA-D07-SHOWS-1SGM20-PL-BK - 1419267

Please be informed that the data shown in this PDF Document is generated from our Online Catalog. Please find the complete data in the user's documentation. Our General Terms of Use for Downloads are valid (<http://phoenixcontact.com/download>)



Box mounting bases D7, with single locking latch, material: PA, cable outlets: 1, lateral, height: 27.9 mm, cable gland: with, support sleeve: no, 1x M20, Standard, open floor



Key Commercial Data

Packing unit	1 pc
GTIN	 4 0 5 5 6 2 6 1 6 0 1 8 4
GTIN	4055626160184

Technical data

Dimensions

Height	27.9 mm
Width	38 mm
Length	24.2 mm
External cable diameter	4 mm ... 10 mm
Length of the assembly cutout	21 mm
Width of the assembly cutout	21 mm

Ambient conditions

Degree of protection (IP)	IP66
Ambient temperature (operation)	-40 °C ... 125 °C

General

Note	for contact inserts HC-A03, A04, D07, D08, Q02, Q03, Q04, Q05, Q07, Q12
Size	D7
Housing type	Box mounting bases
Color	black
Locking type	with single locking latch
No. of cable outlets	1

Housing - HC-STA-D07-SHOWS-1SGM20-PL-BK - 1419267

Technical data

General

Cable outlet	lateral
Screw connection	with
Type of the screw connection	1x M20
Housing material	PA
Seal material	NBR
Material lock	PA
Flammability rating according to UL 94	V0 (Housing)
	V0 (Interlock)

Environmental Product Compliance

China RoHS	Environmentally Friendly Use Period = 50 years
	For details about hazardous substances go to tab "Downloads", Category "Manufacturer's declaration"

Drawings

Housing - HC-STA-D07-SHOWS-1SGM20-PL-BK - 1419267

Dimensional drawing

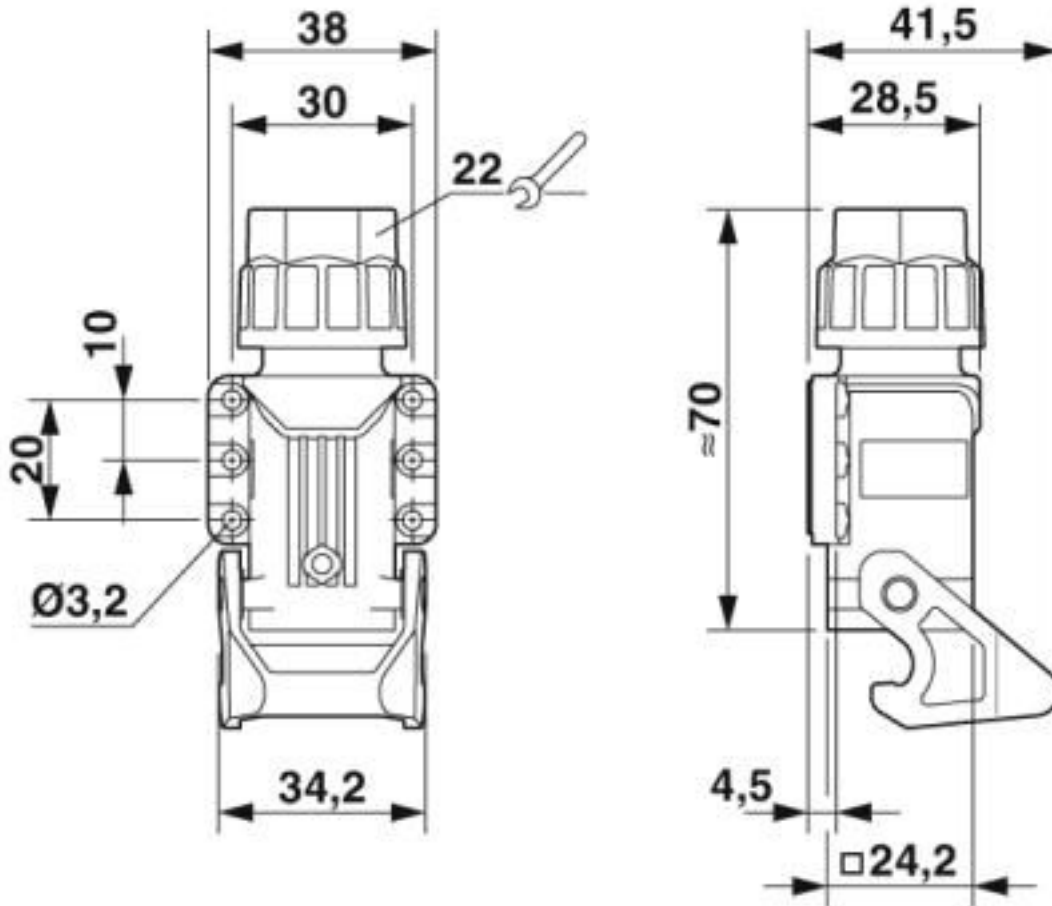

Dimensional drawing

Housing - HC-STA-D07-SHOWS-1SGM20-PL-BK - 1419267

Dimensional drawing

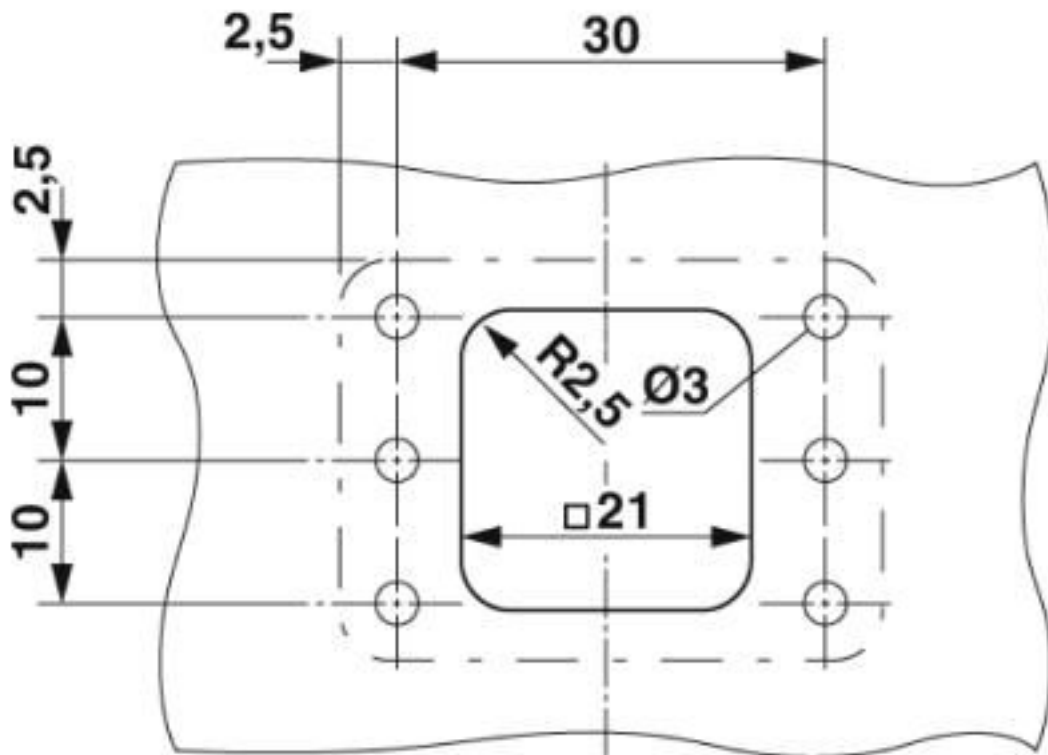

Mounting cutout

Classifications

eCl@ss

eCl@ss 10.0.1	27440202
eCl@ss 5.1	27261200
eCl@ss 6.0	27261200
eCl@ss 7.0	27440202
eCl@ss 8.0	27440202
eCl@ss 9.0	27440202

ETIM

ETIM 5.0	EC000437
ETIM 6.0	EC000437
ETIM 7.0	EC000437

UNSPSC

UNSPSC 13.2	31261501
UNSPSC 18.0	31261501
UNSPSC 19.0	31261501
UNSPSC 20.0	31261501

Housing - HC-STA-D07-SHOWS-1SGM20-PL-BK - 1419267

Classifications

UNSPSC

UNSPSC 21.0	31261501
-------------	----------

Approvals

Approvals

Approvals

EAC / DNV GL

Ex Approvals

Approval details

EAC		RU C- DE.AI30.B.01102
-----	--	--------------------------

DNV GL		https://approvalfinder.dnvgl.com/	TAE000037S
--------	--	---	------------

Accessories

Accessories

Housing latches

Housing brackets - HC-D07-SL-PLBK - 1424440



Replacement latch for HC-D7 housing

Labeled device marker

Plastic label - US-EMLP (11X9) CUS - 0830073



Plastic label, can be ordered: by card, white, labeled according to customer specifications, mounting type: adhesive, lettering field size: 11 x 9 mm, Number of individual labels: 135

Housing - HC-STA-D07-SHOWS-1SGM20-PL-BK - 1419267

Accessories

Seal

Seal - HC-D07-SG-RBK - 1424441



Replacement seal for HC-D7 housing

Phoenix Contact 2020 © - all rights reserved
<http://www.phoenixcontact.com>

PHOENIX CONTACT GmbH & Co. KG
Flachsmarktstr. 8
32825 Blomberg
Germany
Tel. +49 5235 300
Fax +49 5235 3 41200
<http://www.phoenixcontact.com>

Mouser Electronics

Authorized Distributor

Click to View Pricing, Inventory, Delivery & Lifecycle Information:

[Phoenix Contact:](#)

[1419267](#)