

Cable gland - G-INS-M12-S68N-PNES-LG - 1417652

Please be informed that the data shown in this PDF Document is generated from our Online Catalog. Please find the complete data in the user's documentation. Our General Terms of Use for Downloads are valid (<http://phoenixcontact.com/download>)



Cable gland, cable gland material: PA, external cable diameter 3 mm ... 6.5 mm, shielding: no, connecting thread: M12 x 1.5, color: lightgrey RAL 7035

Your advantages

- ✔ Plastic material conforms to UL 746C f1

Key Commercial Data

Packing unit	10 pc
Minimum order quantity	10 pc
GTIN	 4 055626 120959
GTIN	4055626120959

Technical data

Dimensions

Length	32 mm
Wrench size, union nut	15 mm
Wrench size, support	15 mm
Hexagon angular dimension	17.1 mm
Length of the connecting thread	8 mm
Feed-through hole diameter	12.1 mm ... 12.2 mm
External cable diameter	3 mm ... 6.5 mm
	3 mm ... 6.5 mm (for UL 514 B)

Ambient conditions

Degree of protection (IP)	IP68 (5 bar / 0.5 h)
	IP66
Ambient temperature (operation)	-40 °C ... 100 °C (static)

General

Cable gland - G-INS-M12-S68N-PNES-LG - 1417652

Technical data

General

No. of conductors	1
Cable gland material	PA
Cable seal material	CR
Flammability rating according to UL 94	V2
	V2 (Housing)
Shielded	no
Thread type on connection side	M12 x 1.5
Torque	2 Nm ± ()
Color	lightgrey RAL 7035
Impact category	2
Execution of the strain relief	A
Assembly instructions	1) Mount screw connection support in the housing using the correct torque 2) Insert cable 3) Tighten union nut using the correct torque
Manufacturer	BIMED
Manufacturer Designation	BM-1S

Standards and Regulations

Flammability rating according to UL 94	V2
--	----

Environmental Product Compliance

China RoHS	Environmentally friendly use period: unlimited = EFUP-e
	No hazardous substances above threshold values

Drawings

Cable gland - G-INS-M12-S68N-PNES-LG - 1417652

Dimensional drawing

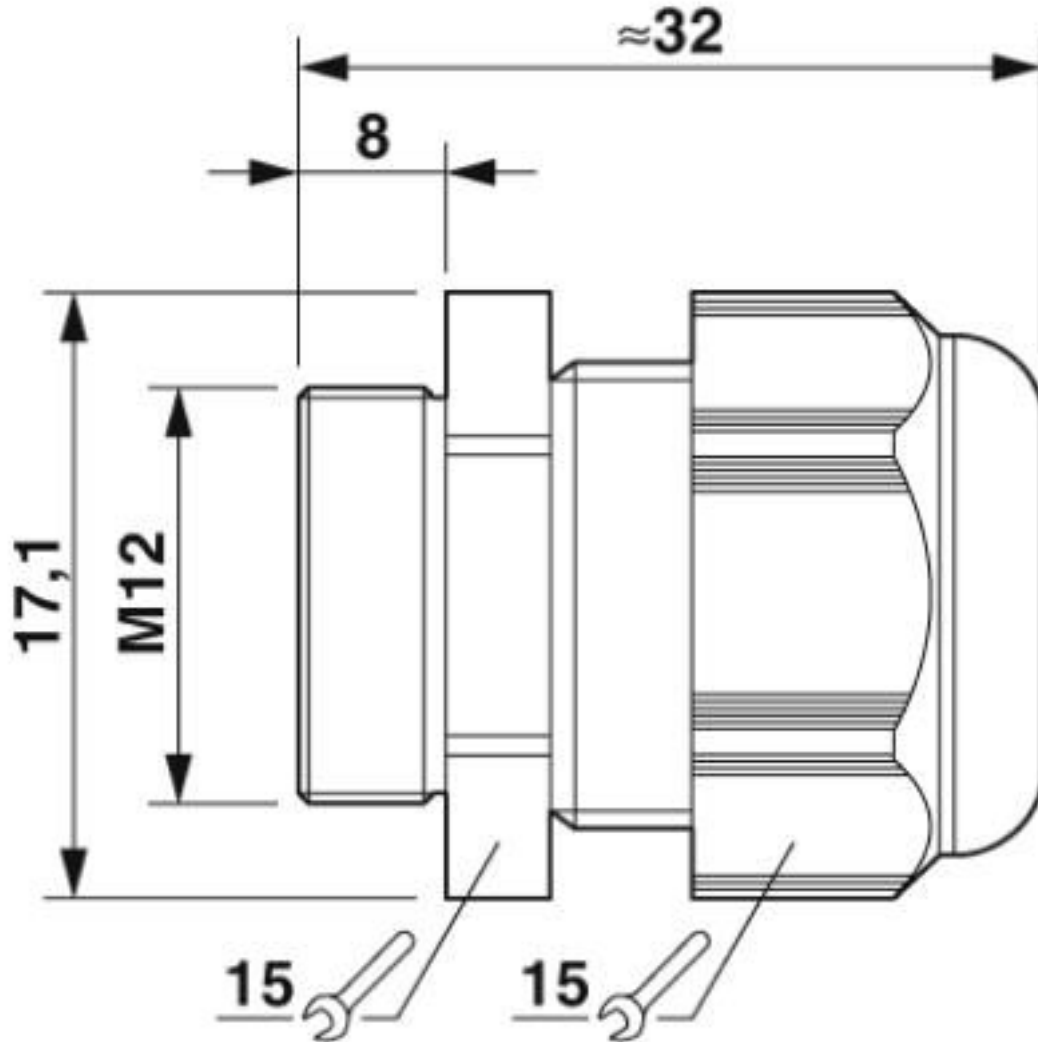

Dimensional drawing

Classifications

eCl@ss

eCl@ss 10.0.1	27144432
eCl@ss 4.0	27141200
eCl@ss 4.1	27141200
eCl@ss 5.0	27149100
eCl@ss 5.1	27149109
eCl@ss 6.0	27149100
eCl@ss 7.0	27149109
eCl@ss 8.0	27149109

Cable gland - G-INS-M12-S68N-PNES-LG - 1417652

Classifications

eCl@ss

eCl@ss 9.0	27144432
------------	----------

ETIM

ETIM 5.0	EC000441
ETIM 6.0	EC000441
ETIM 7.0	EC000441

UNSPSC

UNSPSC 13.2	39121311
UNSPSC 18.0	39121311
UNSPSC 19.0	39121311
UNSPSC 20.0	39121311
UNSPSC 21.0	39121311

Approvals

Approvals

Approvals

UL Recognized / cUL Recognized / cULus Recognized

Ex Approvals

Approval details

UL Recognized		http://database.ul.com/cgi-bin/XYV/template/LISEXT/1FRAME/index.htm	E199260
---------------	---	---	---------

cUL Recognized		http://database.ul.com/cgi-bin/XYV/template/LISEXT/1FRAME/index.htm	E199260
----------------	---	---	---------

cULus Recognized			
------------------	---	--	--

Accessories

Accessories

Flat nut

Cable gland - G-INS-M12-S68N-PNES-LG - 1417652

Accessories

Counter nut - A-INL-M12-P-LG - 1417659



Counter nut, material: PA 6 GF 30, for threads M12 x 1.5, color: lightgrey RAL 7035

Sealing plugs

Closing cap - SEALING PLUG 5X12 RD - 1400253



Closing cap, material: PA, color: red

Phoenix Contact 2020 © - all rights reserved
<http://www.phoenixcontact.com>

PHOENIX CONTACT GmbH & Co. KG
Flachsmarktstr. 8
32825 Blomberg
Germany
Tel. +49 5235 300
Fax +49 5235 3 41200
<http://www.phoenixcontact.com>

Mouser Electronics

Authorized Distributor

Click to View Pricing, Inventory, Delivery & Lifecycle Information:

[Phoenix Contact:](#)

[1417652](#)