

# Housing - HC-D25-TFL-72/O1PG21G - 1416387

Please be informed that the data shown in this PDF Document is generated from our Online Catalog. Please find the complete data in the user's documentation. Our General Terms of Use for Downloads are valid (<http://phoenixcontact.com/download>)



Sleeve housing D25, for single locking latch, material: Aluminum die-cast, cable outlets: 1, straight, height: 72 mm, cable gland: none, support sleeve: yes, 1x Pg21, Standard



## Key Commercial Data

Packing unit	10 pc
GTIN	
GTIN	4055626072494

## Technical data

### Dimensions

Height	72 mm
Width	36 mm
Length	79.5 mm

### Ambient conditions

Degree of protection of housing (IP)	IP65
Ambient temperature (operation)	-40 °C ... 125 °C

### General

Note	For contact inserts HC-D25, A16
Size	D25
Housing type	Sleeve housing
Locking type	for single locking latch
No. of cable outlets	1
Cable outlet	straight
Screw connection	none
Type of the screw connection	1x Pg21
Housing material	Aluminum die-cast
Housing surface material	Powder-coated, gray

# Housing - HC-D25-TFL-72/O1PG21G - 1416387

## Technical data

### General

Seal material	NBR
---------------	-----

### Environmental Product Compliance

China RoHS	Environmentally friendly use period: unlimited = EFUP-e
	No hazardous substances above threshold values

## Drawings

Dimensional drawing

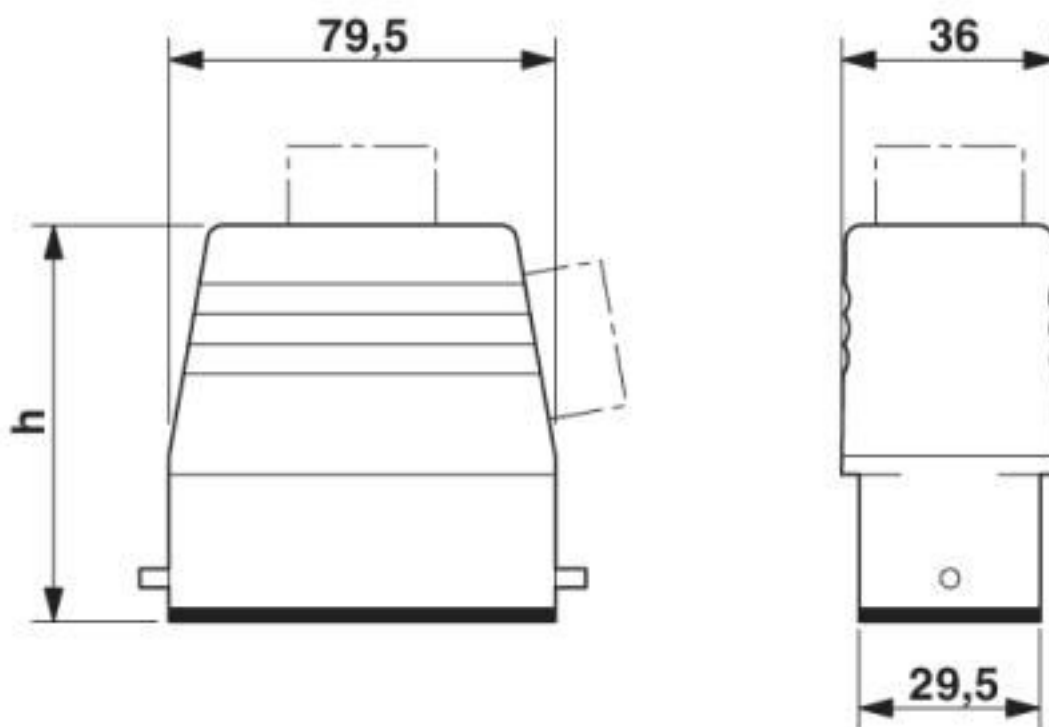

Dimensional drawing

## Classifications

### eCl@ss

eCl@ss 5.1	27261200
eCl@ss 6.0	27261200
eCl@ss 7.0	27440202
eCl@ss 8.0	27440202
eCl@ss 9.0	27440202

### ETIM

ETIM 5.0	EC000437
----------	----------

# Housing - HC-D25-TFL-72/O1PG21G - 1416387

## Classifications

### ETIM

ETIM 6.0	EC000437
ETIM 7.0	EC000437

### UNSPSC

UNSPSC 13.2	31261501
UNSPSC 19.0	31261501

## Approvals

### Approvals

Approvals

EAC / DNV GL

Ex Approvals

### Approval details

EAC		RU C- DE.AI30.B.01102
-----	--	--------------------------

DNV GL		<a href="https://approvalfinder.dnvgl.com/">https://approvalfinder.dnvgl.com/</a>	TAE000037S
--------	--	---	------------

## Accessories

### Accessories

#### Full screw connection

Cable gland - G-INS-PG21-M68N-PNES-GY - 1411145



Cable gland, cable gland material: PA, external cable diameter 13 mm ... 18 mm, shielding: no, connecting thread: Pg21, color: silver-gray RAL 7001

## Housing - HC-D25-TFL-72/O1PG21G - 1416387

### Accessories

Cable gland - G-INS-PG21-M68N-NNES-S - 1411175



Cable gland, cable gland material: Nickel-plated brass, external cable diameter 13 mm ... 18 mm, shielding: no, connecting thread: Pg21, color: silver, with O-ring

---

Cable gland - G-INSEC-PG21-M68N-NNES-S - 1411200



Cable gland, cable gland material: Nickel-plated brass, external cable diameter 13 mm ... 18 mm, shielding: yes, connecting thread: Pg21, color: silver, with O-ring

---

### Plug for cable screw gland

Screw plug - HC-BS-PG21 - 1674529



Screw plug, material: Brass, nickel-plated, connecting thread: Pg21, color: silver

---

---

Phoenix Contact 2020 © - all rights reserved  
<http://www.phoenixcontact.com>

PHOENIX CONTACT GmbH & Co. KG  
Flachsmarktstr. 8  
32825 Blomberg  
Germany  
Tel. +49 5235 300  
Fax +49 5235 3 41200  
<http://www.phoenixcontact.com>

# Mouser Electronics

Authorized Distributor

Click to View Pricing, Inventory, Delivery & Lifecycle Information:

[Phoenix Contact:](#)

[1416387](#)