

## Panel feed-through - QPD W 3PE1,5 M20 0,5 BK - 1414681

Please be informed that the data shown in this PDF Document is generated from our Online Catalog. Please find the complete data in the user's documentation. Our General Terms of Use for Downloads are valid (<http://phoenixcontact.com/download>)



Panel feed-through, QUICKON connection, number of positions: 3+PE, 0.5 mm<sup>2</sup> ... 1.5 mm<sup>2</sup>, 690 V, 17.5 A, black, without QUICKON nut, assembly thread: M20, Single wires, 1.5 mm<sup>2</sup>, cable length: 0.5 m

### Your advantages

- ✓ Innovative and time saving - QUICKON fast connection for time saving of up to 80 % for on-site connection
- ✓ Convenient: quick and easy assembly without special tools
- ✓ Robust throughout: housing with IP68/IP69K and IK07 protection for a wide range of applications
- ✓ Safer connection thanks to polarization against mismatching and touch-proof protection according to DIN EN 0105
- ✓ Efficient - by using panel feed-throughs, devices no longer need to be opened in order to connect cables

### Key Commercial Data

Packing unit	1 pc
GTIN	 4 055626 031347
GTIN	4055626031347

### Technical data

#### General

Type	QPD 4x1,5
Length of cable	0.5 m
Color	black
Locking type	Screw locking
Connection method	QUICKON connection IDC connection
Number of positions	4
Note number of positions	3+PE
Tightening torque, union nut	8 Nm
Tightening torque, counter nut	5 Nm
Number of connections	10

# Panel feed-through - QPD W 3PE1,5 M20 0,5 BK - 1414681

## Technical data

### General

Conductor cross section flexible min.	0.5 mm <sup>2</sup>
Conductor cross section flexible max.	1.5 mm <sup>2</sup>
Conductor cross section solid min.	0.5 mm <sup>2</sup>
Conductor cross section solid max.	1.5 mm <sup>2</sup>
Conductor cross section AWG min.	20
Conductor cross section AWG max.	16

### Cabel

Structure of individual litz in acc. with VDE 0295 / smallest wire diameter	VDE 0295 class 1 to 6/min. 0.15 mm
Wire insulation material	PVC/PE/TPE/rubber
Wire diameter including insulation	1.6 mm ... 3 mm
Conductor cross section	1.5 mm <sup>2</sup>
Wire colors	black, brown, gray, green/yellow
Position marking	1, 2, 3, PE

### Ambient conditions

Degree of protection	IP66
	IP68 (2 m / 24 h)
	IP69K
Ambient temperature (operation)	-40 °C ... 100 °C
Ambient temperature (storage/transport)	-40 °C ... 100 °C
Temperature when conductor connected	-5 °C ... 50 °C

### Electrical characteristics

Nominal current I <sub>N</sub>	17.5 A
Nominal voltage U <sub>N</sub>	690 V AC
	690 V DC
Rated current	17.5 A
Rated voltage (III/3)	690 V
Rated voltage (III/2)	1000 V
Rated voltage (II/2)	1000 V
Rated surge voltage (III/3)	6 kV
Rated surge voltage (III/2)	8 kV
Rated surge voltage (II/2)	8 kV

### Mechanical characteristics

QUICKON connectability	max. 10
Category of shock impact	IK07

### Material data

Contact material	Cu
Contact surface material	silver-plated
Contact carrier material	PA

# Panel feed-through - QPD W 3PE1,5 M20 0,5 BK - 1414681

## Technical data

### Material data

Insulating material	PA
Flammability rating according to UL 94	V0
Overvoltage category	III
Degree of pollution	3

### Standards and Regulations

Category of shock impact	IK07
Flammability rating according to UL 94	V0

### Environmental Product Compliance

China RoHS	Environmentally Friendly Use Period = 50 years
	For details about hazardous substances go to tab "Downloads", Category "Manufacturer's declaration"

## Drawings

Diagram

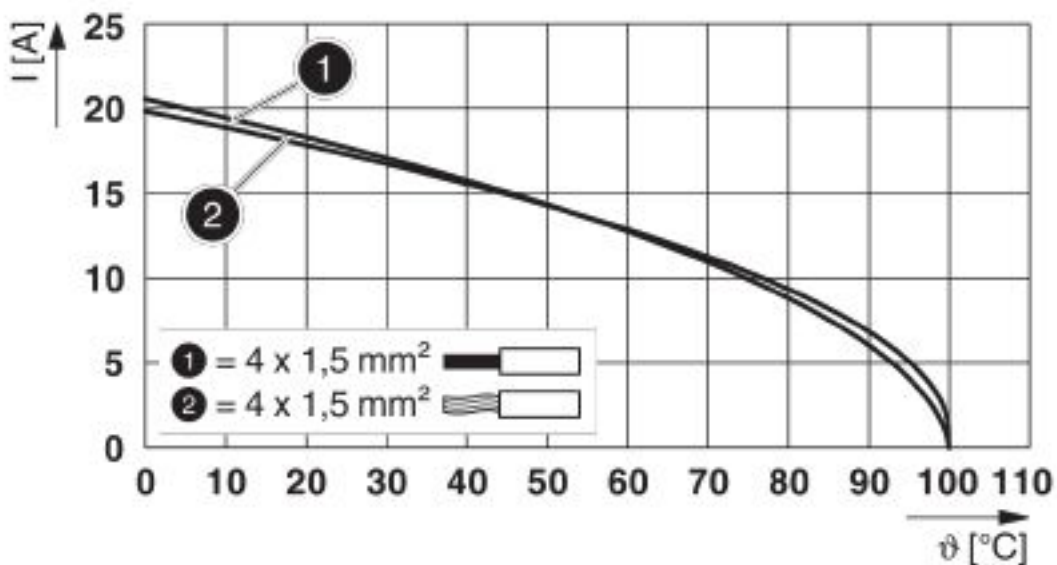

Derating diagram

# Panel feed-through - QPD W 3PE1,5 M20 0,5 BK - 1414681

Dimensional drawing

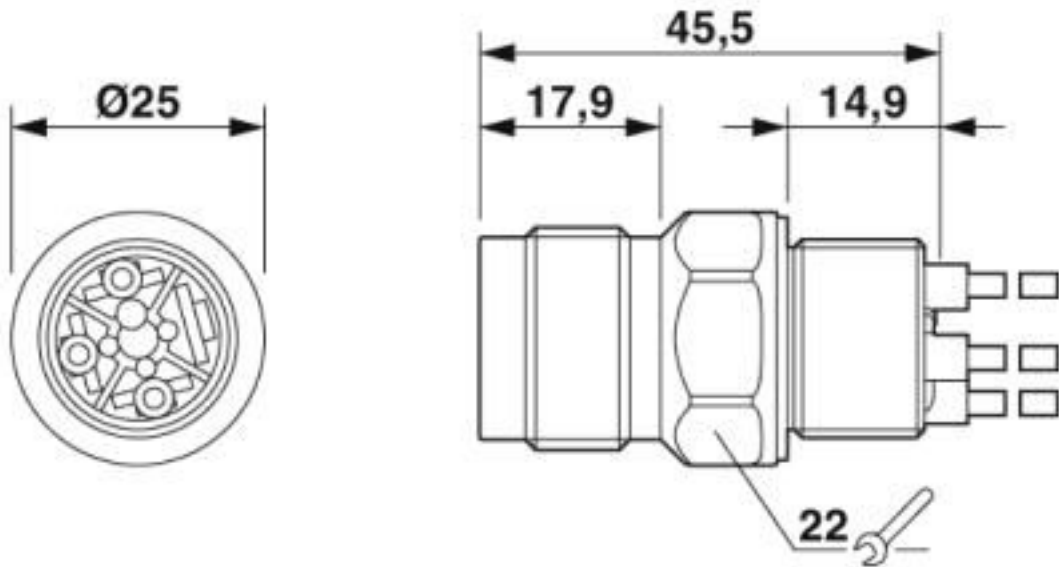

Dimensional drawing

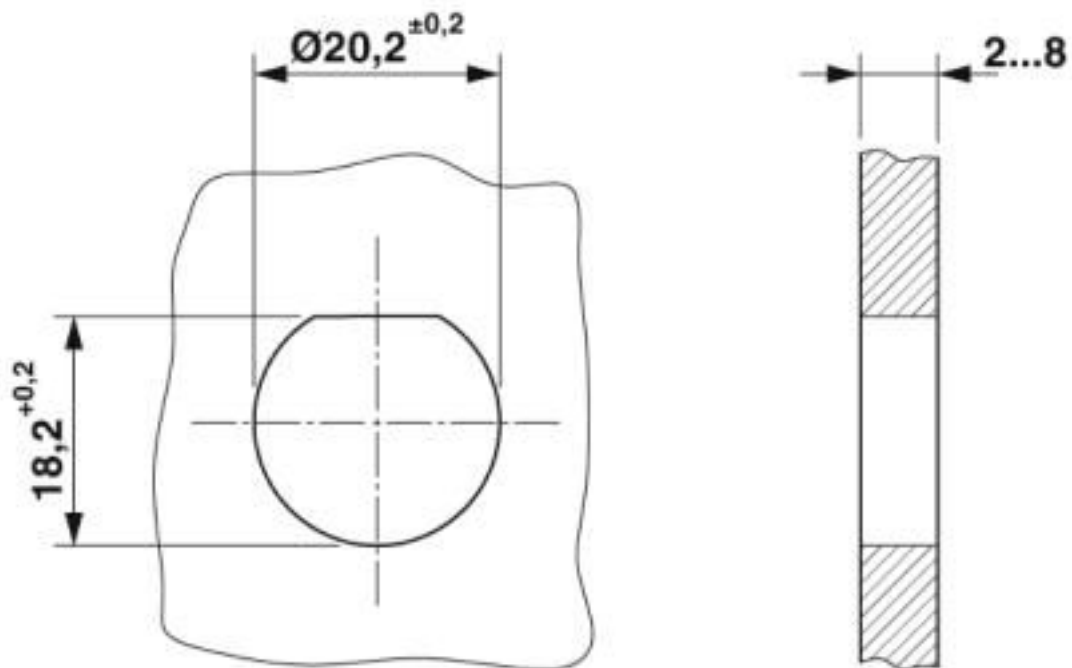

Housing cutout

Classifications

eCl@ss

eCl@ss 10.0.1	27440602
---------------	----------

# Panel feed-through - QPD W 3PE1,5 M20 0,5 BK - 1414681

## Classifications

### eCl@ss

eCl@ss 4.0	27140800
eCl@ss 4.1	27140800
eCl@ss 5.0	27143400
eCl@ss 5.1	27143400
eCl@ss 6.0	27143400
eCl@ss 7.0	27440602
eCl@ss 8.0	27440602
eCl@ss 9.0	27440602

### ETIM

ETIM 5.0	EC002566
ETIM 6.0	EC002566
ETIM 7.0	EC002566

### UNSPSC

UNSPSC 13.2	39121413
UNSPSC 18.0	39121522
UNSPSC 19.0	39121522
UNSPSC 20.0	39121522
UNSPSC 21.0	39121522

## Approvals

### Approvals

#### Approvals

EAC / EAC / DNV GL / IECCEB Scheme / UL Listed / cUL Listed / VDE Zeichengenehmigung / cULus Listed

#### Ex Approvals

### Approval details

EAC		RU C- DE.AI30.B.01102
-----	--	--------------------------

EAC		RU C- DE.BL08.B.00511
-----	--	--------------------------

# Panel feed-through - QPD W 3PE1,5 M20 0,5 BK - 1414681

## Approvals

DNV GL		<a href="https://approvalfinder.dnvgl.com/">https://approvalfinder.dnvgl.com/</a>	TAE00003J5
--------	--	---	------------

IECEE CB Scheme		<a href="http://www.iecee.org/">http://www.iecee.org/</a>	DE1-61559
-----------------	--	---	-----------

UL Listed		<a href="http://database.ul.com/cgi-bin/XYV/template/LISEXT/1FRAME/index.htm">http://database.ul.com/cgi-bin/XYV/template/LISEXT/1FRAME/index.htm</a>	E468743
-----------	--	---	---------

cUL Listed		<a href="http://database.ul.com/cgi-bin/XYV/template/LISEXT/1FRAME/index.htm">http://database.ul.com/cgi-bin/XYV/template/LISEXT/1FRAME/index.htm</a>	E468743
------------	--	---	---------

VDE Zeichengenehmigung		<a href="http://www2.vde.com/de/Institut/Online-Service/VDE-gepruefteProdukte/Seiten/Online-Suche.aspx">http://www2.vde.com/de/Institut/Online-Service/VDE-gepruefteProdukte/Seiten/Online-Suche.aspx</a>	40029149
Nominal voltage UN	690 V		
Nominal current IN	17.5 A		
mm <sup>2</sup> /AWG/kcmil	0.5-1.5		

cULus Listed			
--------------	--	--	--

## Accessories

Accessories

Coding element

Coding profile - CP-QPD 3/4X1,5 - 1414729



Coding profile red, for pushing into the QUICKON dome and connector, can be positioned in 90° steps.

## Installation connector

## Panel feed-through - QPD W 3PE1,5 M20 0,5 BK - 1414681

### Accessories

Connector - QPD P 3PE1,5 4-9 BK - 1414703



Connector, QUICKON connection, number of positions: 3+PE, 0.5 mm<sup>2</sup> ... 1.5 mm<sup>2</sup>, 690 V, 17.5 A, black, with QUICKON nut, cable diameter range: 5 mm ... 9.5 mm

---

Connector - QPD P 3PE1,5 8-13 BK - 1414704



Connector, QUICKON connection, number of positions: 3+PE, 0.5 mm<sup>2</sup> ... 1.5 mm<sup>2</sup>, 690 V, 17.5 A, black, with QUICKON nut, cable diameter range: 10 mm ... 13 mm

---

### Installation pressure nut

Nut - QPD N 3PE1,5 4-9 BK - 1415097



Nut, QUICKON connection, number of positions: 3+PE, 0.5 mm<sup>2</sup> ... 1.5 mm<sup>2</sup>, 690 V, 17.5 A, black, cable diameter range: 5 mm ... 9.5 mm

---

Nut - QPD N 3PE1,5 8-13 BK - 1415098



Nut, QUICKON connection, number of positions: 3+PE, 0.5 mm<sup>2</sup> ... 1.5 mm<sup>2</sup>, 690 V, 17.5 A, black, cable diameter range: 10 mm ... 13 mm

---

### Protective cap

Protective cap - QPD QSK 3/4X1,5 - 1414723



Protective cap plastic, for QPD-QUICKON connection 3(4) x 1.5 mm<sup>2</sup>, IP50

---

## Panel feed-through - QPD W 3PE1,5 M20 0,5 BK - 1414681

### Accessories

Protective cap - QPD QSK BK 3/4X1,5 FS - 1414722

Protective cap, plastic, for QUICKON connection, black, with retaining cord, IP68



---

Flat nut - Q-MU-M20 BK - 1586099

Flat nut, color: black



---

Phoenix Contact 2020 © - all rights reserved  
<http://www.phoenixcontact.com>

PHOENIX CONTACT GmbH & Co. KG  
Flachsmarktstr. 8  
32825 Blomberg  
Germany  
Tel. +49 5235 300  
Fax +49 5235 3 41200  
<http://www.phoenixcontact.com>



# Mouser Electronics

Authorized Distributor

Click to View Pricing, Inventory, Delivery & Lifecycle Information:

[Phoenix Contact:](#)

[1414681](#)