

Housing - HC-STA-B10-CHWD-1TTM32-ELC-AL - 1412580

Please be informed that the data shown in this PDF Document is generated from our Online Catalog. Please find the complete data in the user's documentation. Our General Terms of Use for Downloads are valid (<http://phoenixcontact.com/download>)



Coupling housings B10, with double locking latch, material: Die-cast aluminum, salt water resistant, cable outlets: 1, straight, height: 73 mm, cable gland: none, support sleeve: no, 1x M32, Standard

Your advantages

- ☑ good shielding in the event of electromagnetic interference



Key Commercial Data

Packing unit	1 pc
GTIN	
GTIN	4055626030555

Technical data

Dimensions

Height	73 mm
Width	44 mm
Length	73 mm

Ambient conditions

Degree of protection (IP)	IP66
	IP67
Degree of protection (NEMA)	4 (UL 50e)
	4X (UL 50e)
	12 (UL 50e)
Ambient temperature (operation)	-40 °C ... 125 °C

General

Note	For contact inserts HC-B10, BB18, DD42, M, K8/24
Size	B10
Housing type	Coupling housings

Housing - HC-STA-B10-CHWD-1TTM32-ELC-AL - 1412580

Technical data

General

Color	gray aluminum
Locking type	with double locking latch
No. of cable outlets	1
Cable outlet	straight
Screw connection	none
Type of the screw connection	1x M32
Housing material	Die-cast aluminum, salt water resistant
Housing surface material	uncoated
Seal material	NBR, conductive
Material lock	PA
Flammability rating according to UL 94	V0 (Interlock)

Environmental Product Compliance

China RoHS	Environmentally Friendly Use Period = 50 years
	For details about hazardous substances go to tab "Downloads", Category "Manufacturer's declaration"

Drawings

Dimensional drawing

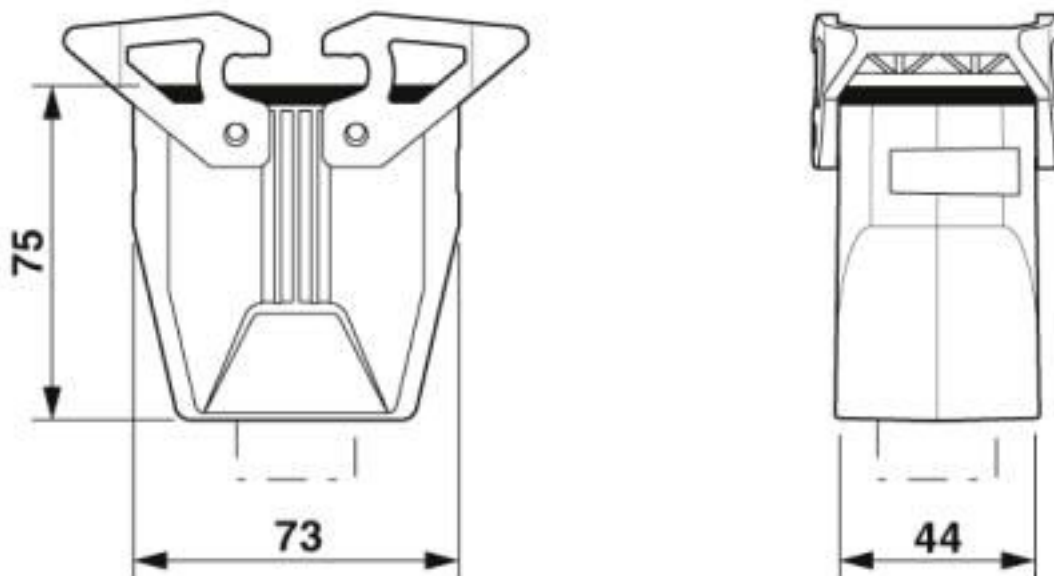

Dimensional drawing

Classifications

eCl@ss

eCl@ss 10.0.1	27440202
---------------	----------

Housing - HC-STA-B10-CHWD-1TTM32-ELC-AL - 1412580

Classifications

eCl@ss

eCl@ss 5.1	27261200
eCl@ss 6.0	27261200
eCl@ss 7.0	27440202
eCl@ss 8.0	27440202
eCl@ss 9.0	27440202

ETIM

ETIM 5.0	EC000437
ETIM 6.0	EC000437
ETIM 7.0	EC000437

UNSPSC

UNSPSC 13.2	31261501
UNSPSC 18.0	31261501
UNSPSC 19.0	31261501
UNSPSC 20.0	31261501
UNSPSC 21.0	31261501

Approvals

Approvals

Approvals

EAC / DNV GL

Ex Approvals

Approval details

EAC		RU C- DE.AI30.B.01102
-----	--	--------------------------

DNV GL		https://approvalfinder.dnvgl.com/	TAE000037S
--------	--	---	------------

Accessories

Accessories

Full screw connection

Housing - HC-STA-B10-CHWD-1TTM32-ELC-AL - 1412580

Accessories

Cable gland - G-INS-M32-M68N-NNES-S - 1411166



Cable gland, cable gland material: Nickel-plated brass, external cable diameter 15 mm ... 21 mm, shielding: no, connecting thread: M32 x 1.5, color: silver, with O-ring

Cable gland - G-INSEC-M32-M68N-NCRS-S - 1411191



Cable gland, cable gland material: Nickel-plated brass, external cable diameter 14 mm ... 21 mm, shielding: yes, connecting thread: M32 x 1.5, color: silver, with O-ring

Housing latches

Housing brackets - HC-STA-B10-24-DL-PLBK - 1412886



Double locking latch for B10 / B16 / B24 housing, HC-EVO...AL and HC-STA...AL

Labeled device marker

Plastic label - US-EMLP (20X9) CUS - 0830085



Plastic label, can be ordered: by card, white, labeled according to customer specifications, mounting type: adhesive, lettering field size: 20 x 9 mm, Number of individual labels: 75

Seal

Profile gasket - HC-B10-SP-CBK - 1411479



Profile gasket for HEAVYCON EVO supporting base element type B10, conductive

Phoenix Contact 2020 © - all rights reserved
<http://www.phoenixcontact.com>

PHOENIX CONTACT GmbH & Co. KG
Flachsmarktstr. 8
32825 Blomberg
Germany
Tel. +49 5235 300
Fax +49 5235 3 41200
<http://www.phoenixcontact.com>

Mouser Electronics

Authorized Distributor

Click to View Pricing, Inventory, Delivery & Lifecycle Information:

[Phoenix Contact:](#)

[1412580](#)