

Cable gland - HC-B-G-M20-ER-AL - 1411442

Please be informed that the data shown in this PDF Document is generated from our Online Catalog. Please find the complete data in the user's documentation. Our General Terms of Use for Downloads are valid (<http://phoenixcontact.com/download>)



EVO metal cable gland with bayonet locking, B series, size M20, cable diameter: 7 - 13 mm



Key Commercial Data

Packing unit	1 pc
GTIN	
GTIN	4046356932417

Technical data

Dimensions

Wrench size, union nut	22 mm
External cable diameter	9 mm ... 12 mm

Ambient conditions

Degree of protection (IP)	IP66
	IP67
Degree of protection (NEMA)	4 (UL 50e)
	4X (UL 50e)
	12 (UL 50e)
Ambient temperature (operation)	-40 °C ... 125 °C (static)

General

Type of the screw connection	M20
No. of conductors	1
Material	Die-cast aluminum, corrosion-resistant
Housing material	Die-cast aluminum, corrosion resistant
Cable gland material	Aluminum
Material, pressure screw	Nickel-plated brass
Seal material	NBR

Cable gland - HC-B-G-M20-ER-AL - 1411442

Technical data

General

Cable seal material	NBR
Sealing material	NBR (O-ring)
Shielded	no
Tightening torque, union nut	7.50 Nm
Color	silver

Environmental Product Compliance

REACH SVHC	Lead 7439-92-1
China RoHS	Environmentally Friendly Use Period = 50 years
	For details about hazardous substances go to tab "Downloads", Category "Manufacturer's declaration"

Drawings

Dimensional drawing

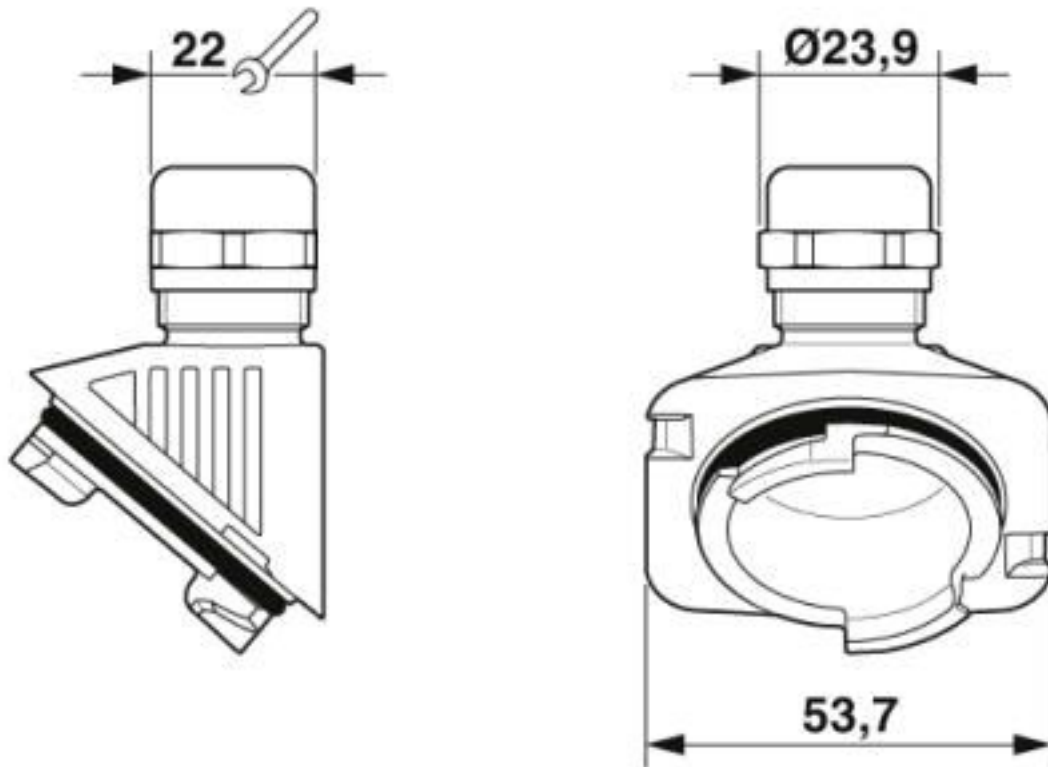

Dimensional drawing

Classifications

eCl@ss

eCl@ss 10.0.1	27144432
---------------	----------

Cable gland - HC-B-G-M20-ER-AL - 1411442

Classifications

eCl@ss

eCl@ss 4.0	27140800
eCl@ss 4.1	27140800
eCl@ss 5.0	27149100
eCl@ss 5.1	27143400
eCl@ss 6.0	27149100
eCl@ss 7.0	27149109
eCl@ss 8.0	27149109
eCl@ss 9.0	27144432

ETIM

ETIM 4.0	EC000441
ETIM 5.0	EC000441
ETIM 6.0	EC000441
ETIM 7.0	EC000441

UNSPSC

UNSPSC 13.2	39121311
UNSPSC 18.0	39121311
UNSPSC 19.0	39121311
UNSPSC 20.0	39121311
UNSPSC 21.0	39121311

Approvals

Approvals

Approvals

UL Recognized / cUL Recognized / DNV GL / EAC-RoHS / EAC / cULus Recognized

Ex Approvals

Approval details

UL Recognized		http://database.ul.com/cgi-bin/XYV/template/LISEXT/1FRAME/index.htm	E255026
---------------	---	---	---------

cUL Recognized		http://database.ul.com/cgi-bin/XYV/template/LISEXT/1FRAME/index.htm	E255026
----------------	---	---	---------

Cable gland - HC-B-G-M20-ER-AL - 1411442

Approvals

DNV GL		https://approvalfinder.dnvgl.com/	TAE000037S
--------	---	---	------------

EAC-RoHS			RU D- DE.HB35.B.00387
----------	---	--	--------------------------

EAC			RU C- DE.AI30.B.01102
-----	---	--	--------------------------

cULus Recognized			
------------------	---	--	--

Phoenix Contact 2020 © - all rights reserved
<http://www.phoenixcontact.com>

PHOENIX CONTACT GmbH & Co. KG
Flachsmarktstr. 8
32825 Blomberg
Germany
Tel. +49 5235 300
Fax +49 5235 3 41200
<http://www.phoenixcontact.com>

Mouser Electronics

Authorized Distributor

Click to View Pricing, Inventory, Delivery & Lifecycle Information:

[Phoenix Contact:](#)

[1411442](#)