

EMV nut - A-INLE-M16-N-S - 1411268

Please be informed that the data shown in this PDF Document is generated from our Online Catalog. Please find the complete data in the user's documentation. Our General Terms of Use for Downloads are valid (<http://phoenixcontact.com/download>)

EMV nut, material: Brass, nickel-plated, for threads M16 x 1.5, color: silver



Key Commercial Data

Packing unit	100 pc
GTIN	
GTIN	4046356923996

Technical data

Dimensions

Length	4.7 mm
Connecting thread diameter	16 mm
Wrench size, counter nut	19 mm
Hexagon angular dimension	21 mm

Ambient conditions

Ambient temperature (operation)	-70 °C ... 220 °C
---------------------------------	-------------------

General

Material	Brass, nickel-plated
Thread type on connection side	M16 x 1.5
Color	silver
Assembly instructions	for EMC cable glands, for removing a non-conductive surface coating

Standards and Regulations

Halogen-free	yes
--------------	-----

Environmental Product Compliance

REACH SVHC	Lead 7439-92-1
China RoHS	Environmentally Friendly Use Period = 50 years

EMV nut - A-INLE-M16-N-S - 1411268

Technical data

Environmental Product Compliance

	For details about hazardous substances go to tab "Downloads", Category "Manufacturer's declaration"
--	---

Drawings

Dimensional drawing

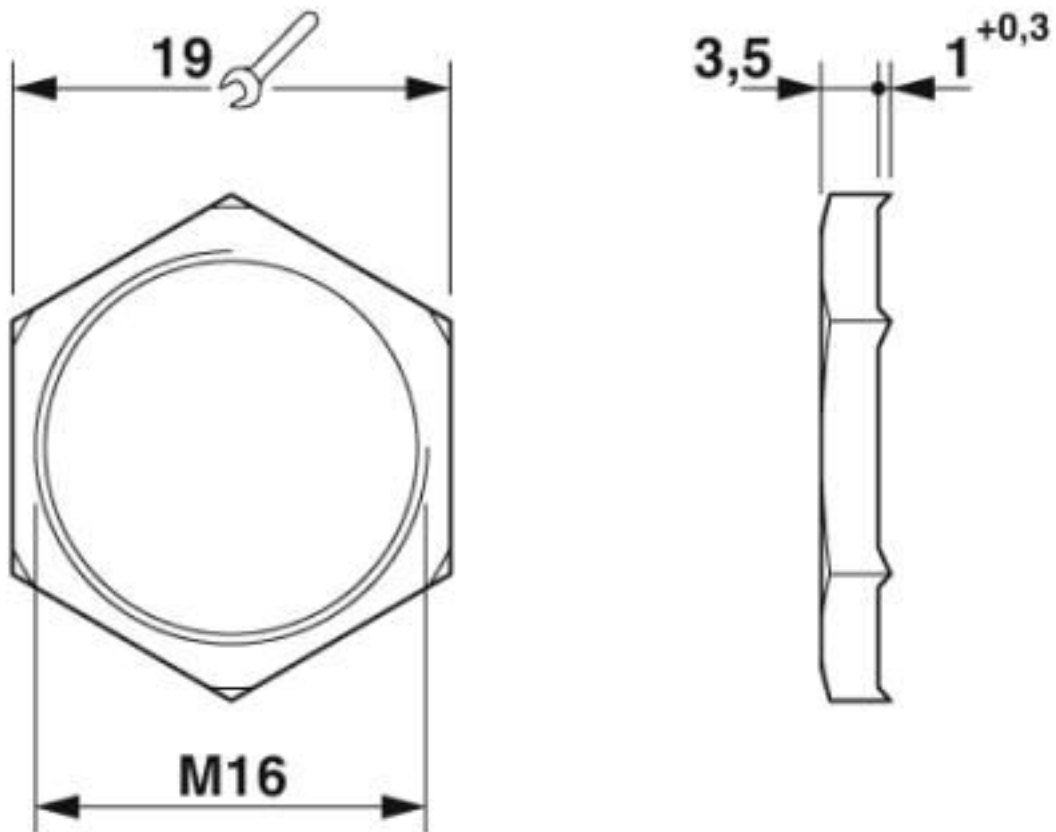

Classifications

eCl@ss

eCl@ss 10.0.1	27144424
eCl@ss 4.0	27141200
eCl@ss 4.1	27141200
eCl@ss 5.0	27149100
eCl@ss 5.1	27149100
eCl@ss 6.0	27149100
eCl@ss 7.0	27069219
eCl@ss 8.0	27069219
eCl@ss 9.0	27144424

EMV nut - A-INLE-M16-N-S - 1411268

Classifications

ETIM

ETIM 4.0	EC000129
ETIM 5.0	EC000129
ETIM 6.0	EC000940
ETIM 7.0	EC000940

UNSPSC

UNSPSC 13.2	31161716
UNSPSC 18.0	31161716
UNSPSC 19.0	31161716
UNSPSC 20.0	31161716
UNSPSC 21.0	31161716

Phoenix Contact 2020 © - all rights reserved
<http://www.phoenixcontact.com>

PHOENIX CONTACT GmbH & Co. KG

Flachsmarktstr. 8

32825 Blomberg

Germany

Tel. +49 5235 300

Fax +49 5235 3 41200

<http://www.phoenixcontact.com>

Mouser Electronics

Authorized Distributor

Click to View Pricing, Inventory, Delivery & Lifecycle Information:

[Phoenix Contact:](#)

[1411268](#)