

Counter nut - A-INL-PG42-N-S - 1411265

Please be informed that the data shown in this PDF Document is generated from our Online Catalog. Please find the complete data in the user's documentation. Our General Terms of Use for Downloads are valid (<http://phoenixcontact.com/download>)

Counter nut, material: Brass, nickel-plated, for threads Pg42, color: silver



Key Commercial Data

| | |
|--------------|---------------|
| Packing unit | 25 pc |
| GTIN | |
| GTIN | 4046356923965 |

Technical data

Dimensions

| | |
|----------------------------|-------|
| Length | 5 mm |
| Connecting thread diameter | 54 mm |
| Wrench size, counter nut | 60 mm |
| Hexagon angular dimension | 65 mm |

Ambient conditions

| | |
|---------------------------------|-------------------|
| Ambient temperature (operation) | -70 °C ... 220 °C |
|---------------------------------|-------------------|

General

| | |
|--------------------------------|----------------------|
| Material | Brass, nickel-plated |
| Thread type on connection side | Pg42 |
| Color | silver |

Standards and Regulations

| | |
|--------------|-----|
| Halogen-free | yes |
|--------------|-----|

Environmental Product Compliance

| | |
|------------|--|
| REACH SVHC | Lead 7439-92-1 |
| China RoHS | Environmentally Friendly Use Period = 50 years |

Counter nut - A-INL-PG42-N-S - 1411265

Technical data

Environmental Product Compliance

| | |
|--|---|
| | For details about hazardous substances go to tab "Downloads", Category "Manufacturer's declaration" |
|--|---|

Drawings

Dimensional drawing

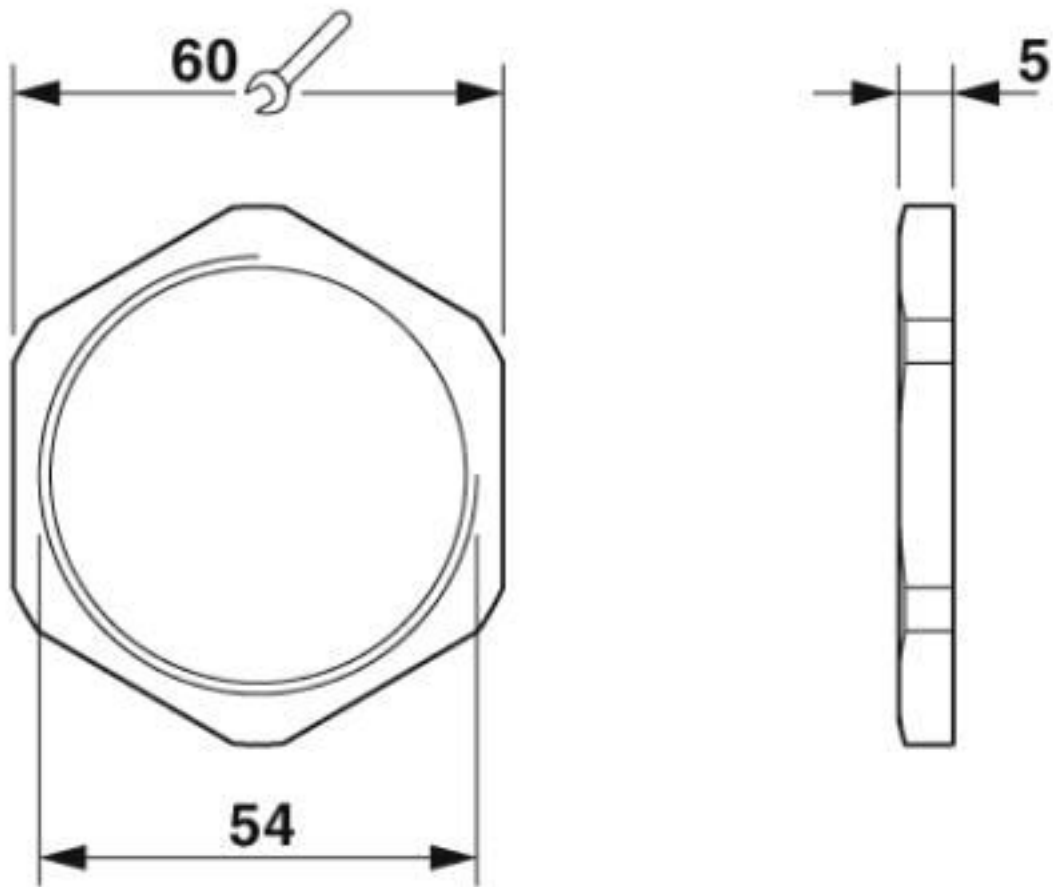

Classifications

eCl@ss

| | |
|---------------|----------|
| eCl@ss 10.0.1 | 27144424 |
| eCl@ss 4.0 | 27141200 |
| eCl@ss 4.1 | 27141200 |
| eCl@ss 5.0 | 27149100 |
| eCl@ss 5.1 | 27149100 |
| eCl@ss 6.0 | 27149100 |
| eCl@ss 7.0 | 27069219 |
| eCl@ss 8.0 | 27069219 |

Counter nut - A-INL-PG42-N-S - 1411265

Classifications

eCl@ss

| | |
|------------|----------|
| eCl@ss 9.0 | 27144424 |
|------------|----------|

ETIM

| | |
|----------|----------|
| ETIM 4.0 | EC000032 |
| ETIM 5.0 | EC000129 |
| ETIM 6.0 | EC000940 |
| ETIM 7.0 | EC000940 |

UNSPSC

| | |
|-------------|----------|
| UNSPSC 13.2 | 31161716 |
| UNSPSC 18.0 | 31161716 |
| UNSPSC 19.0 | 31161716 |
| UNSPSC 20.0 | 31161716 |
| UNSPSC 21.0 | 31161716 |

Phoenix Contact 2020 © - all rights reserved
<http://www.phoenixcontact.com>

PHOENIX CONTACT GmbH & Co. KG
Flachsmarktstr. 8
32825 Blomberg
Germany
Tel. +49 5235 300
Fax +49 5235 3 41200
<http://www.phoenixcontact.com>

Mouser Electronics

Authorized Distributor

Click to View Pricing, Inventory, Delivery & Lifecycle Information:

[Phoenix Contact:](#)

[1411265](#)