

Cable gland - G-INS-PG11-S68N-NNES-S - 1411172

Please be informed that the data shown in this PDF Document is generated from our Online Catalog. Please find the complete data in the user's documentation. Our General Terms of Use for Downloads are valid (<http://phoenixcontact.com/download>)



Cable gland, cable gland material: Nickel-plated brass, external cable diameter 5 mm ... 10 mm, shielding: no, connecting thread: Pg11, color: silver, with O-ring

RoHS

Key Commercial Data

Packing unit	5 pc
Minimum order quantity	5 pc
GTIN	 4 046356 923064
GTIN	4046356923064

Technical data

Dimensions

Length	21 mm
Wrench size, union nut	20 mm
Wrench size, support	20 mm
Hexagon angular dimension	22 mm
Length of the connecting thread	6 mm
Feed-through hole diameter	18.7 mm ... 18.8 mm
External cable diameter	5 mm ... 10 mm
	6 mm ... 10 mm (for UL 514 B)

Ambient conditions

Degree of protection (IP)	IP69 (DIN EN 60529 / IEC 60529)
	IP68 (5 bar, 30 min.)
Degree of protection (NEMA)	4X
Ambient temperature (operation)	-40 °C ... 100 °C (static)

General

No. of conductors	1
Cable gland material	Nickel-plated brass

Cable gland - G-INS-PG11-S68N-NNES-S - 1411172

Technical data

General

Material, insert	Polyamide 6
Cable seal material	CR
O-ring material	Perbunan
Shielded	no
Thread type on connection side	Pg11
Torque	7 Nm ± ()
Color	silver
Assembly instructions	1) Mount screw connection support in the housing using the correct torque 2) Insert cable 3) Tighten union nut using the correct torque
Manufacturer	BIMED
Manufacturer Designation	BSBC-03

Standards and Regulations

Halogen-free	no
--------------	----

Environmental Product Compliance

REACH SVHC	Lead 7439-92-1
China RoHS	Environmentally Friendly Use Period = 50 years
	For details about hazardous substances go to tab "Downloads", Category "Manufacturer's declaration"

Drawings

Cable gland - G-INS-PG11-S68N-NNES-S - 1411172

Dimensional drawing

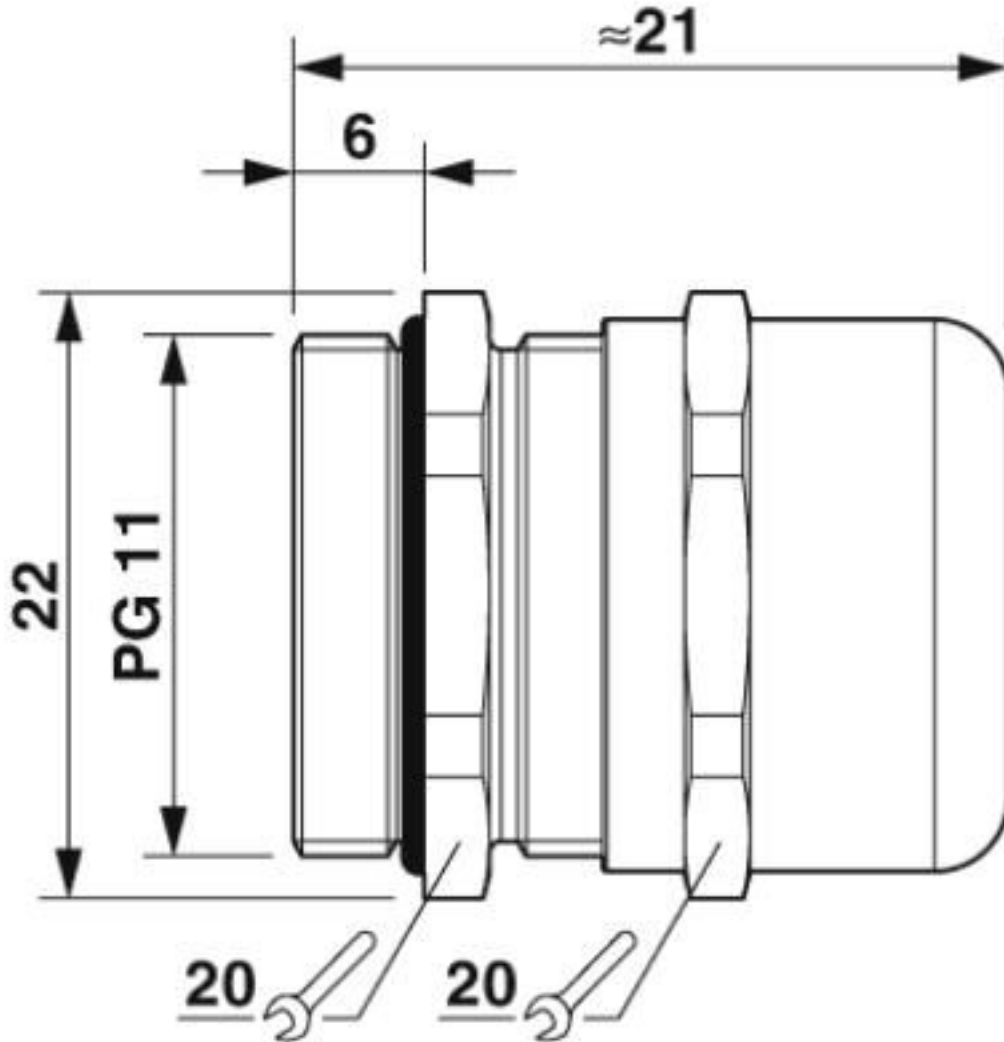

Dimensional drawing

Classifications

eCl@ss

eCl@ss 10.0.1	27144432
eCl@ss 4.0	27081000
eCl@ss 4.1	27081000
eCl@ss 5.0	27149100
eCl@ss 5.1	27081000
eCl@ss 6.0	27149100
eCl@ss 7.0	27149109
eCl@ss 8.0	27149109

Cable gland - G-INS-PG11-S68N-NNES-S - 1411172

Classifications

eCl@ss

eCl@ss 9.0	27144432
------------	----------

ETIM

ETIM 4.0	EC000441
ETIM 5.0	EC000441
ETIM 6.0	EC000441
ETIM 7.0	EC000441

UNSPSC

UNSPSC 13.2	39121311
UNSPSC 18.0	39121311
UNSPSC 19.0	39121311
UNSPSC 20.0	39121311
UNSPSC 21.0	39121311

Approvals

Approvals

Approvals

UL Recognized / cUL Recognized / cULus Recognized

Ex Approvals

Approval details

UL Recognized		http://database.ul.com/cgi-bin/XYV/template/LISEXT/1FRAME/index.htm	E199260
---------------	--	---	---------

cUL Recognized		http://database.ul.com/cgi-bin/XYV/template/LISEXT/1FRAME/index.htm	E199260
----------------	--	---	---------

cULus Recognized			
------------------	--	--	--

Accessories

Accessories

Cable gland - G-INS-PG11-S68N-NNES-S - 1411172

Accessories

Flat nut

Counter nut - A-INL-PG11-N-S - 1411257



Counter nut, material: Brass, nickel-plated, for threads Pg11, color: silver

Sealing plugs

Closing cap - SEALING PLUG 8X16 RD - 1400257



Closing cap, material: PA, color: red

Phoenix Contact 2020 © - all rights reserved
<http://www.phoenixcontact.com>

PHOENIX CONTACT GmbH & Co. KG
Flachsmarktstr. 8
32825 Blomberg
Germany
Tel. +49 5235 300
Fax +49 5235 3 41200
<http://www.phoenixcontact.com>

Mouser Electronics

Authorized Distributor

Click to View Pricing, Inventory, Delivery & Lifecycle Information:

[Phoenix Contact:](#)

[1411172](#)