

Housing - HC-COM-K-SML-O1PG16 - 1408371

Please be informed that the data shown in this PDF Document is generated from our Online Catalog. Please find the complete data in the user's documentation. Our General Terms of Use for Downloads are valid (<http://phoenixcontact.com/download>)



Box mounting base with single locking engagement nose for HC-COM-K-KV-PG16... screw connection, box mounting base is opened from below.



Key Commercial Data

Packing unit	2 pc
GTIN	 4 046356 618113
GTIN	4046356618113

Technical data

Dimensions

Height	33.5 mm
Width	46 mm
Length	54.5 mm
Length of the assembly cutout	26 mm
Width of the assembly cutout	24 mm

Ambient conditions

Degree of protection (IP)	IP65
	IP66
Ambient temperature (operation)	-40 °C ... 125 °C

General

Size	COM
Housing type	Box mounting bases
Color	light gray
Locking type	with single locking latch
No. of cable outlets	1
Cable outlet	lateral
Screw connection	none

Housing - HC-COM-K-SML-O1PG16 - 1408371

Technical data

General

Type of the screw connection	1x Pg16
Material	PC
Housing material	PC
Seal material	NBR
Material lock	Stainless steel
Flammability rating according to UL 94	V0
Assembly instructions	Housing is open for wall side

Standards and Regulations

Flammability rating according to UL 94	V0
--	----

Environmental Product Compliance

China RoHS	Environmentally friendly use period: unlimited = EFUP-e
	No hazardous substances above threshold values

Drawings

Housing - HC-COM-K-SML-O1PG16 - 1408371

Dimensional drawing

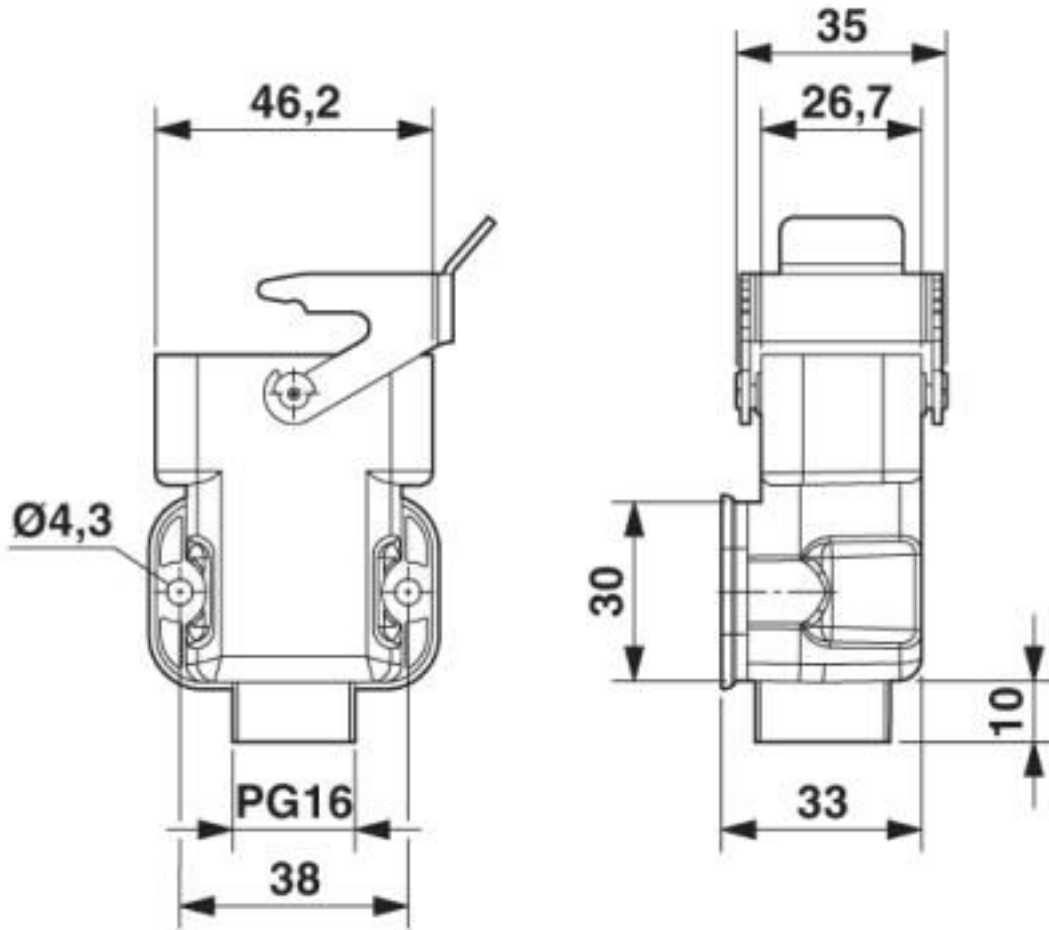

Dimensional drawing

Housing - HC-COM-K-SML-O1PG16 - 1408371

Dimensional drawing

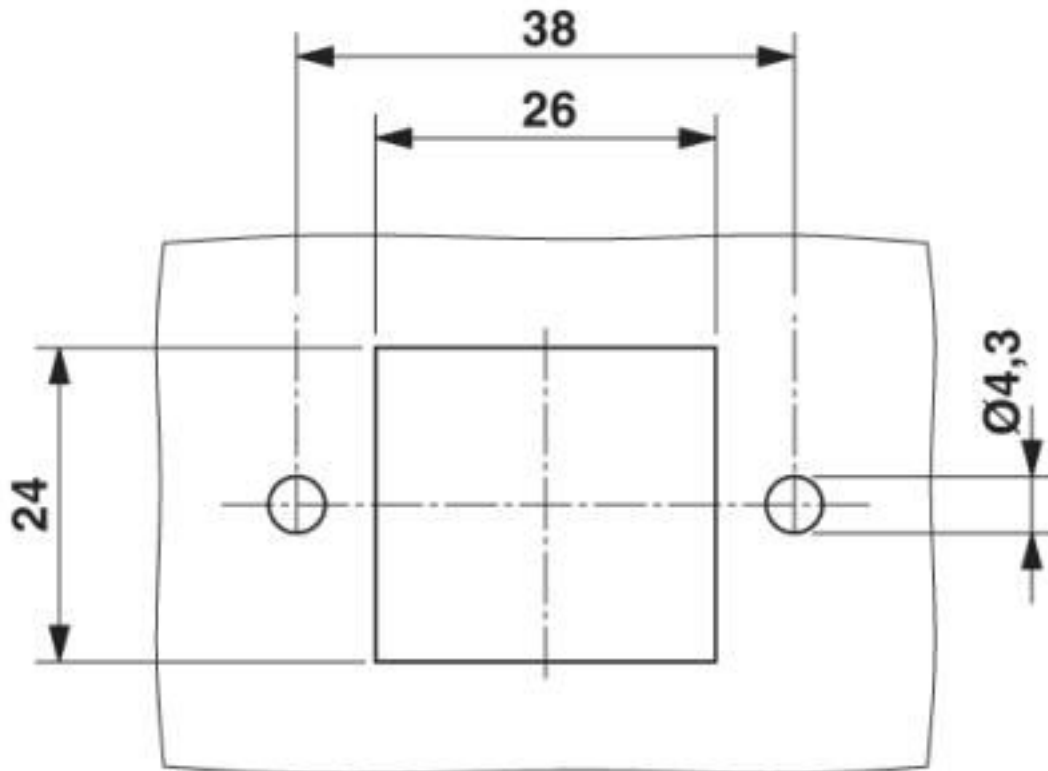

Mounting cutout

Classifications

eCl@ss

eCl@ss 10.0.1	27440202
eCl@ss 4.0	27140800
eCl@ss 4.1	27140800
eCl@ss 5.0	27143400
eCl@ss 5.1	27261200
eCl@ss 6.0	27261200
eCl@ss 7.0	27440202
eCl@ss 8.0	27440202
eCl@ss 9.0	27440202

ETIM

ETIM 4.0	EC000437
ETIM 5.0	EC000437
ETIM 6.0	EC000437
ETIM 7.0	EC000437

Housing - HC-COM-K-SML-O1PG16 - 1408371

Classifications

UNSPSC

UNSPSC 6.01	31261502
UNSPSC 7.0901	31261502
UNSPSC 11	31261502
UNSPSC 12.01	31261502
UNSPSC 13.2	31261501
UNSPSC 18.0	31261501
UNSPSC 19.0	31261501
UNSPSC 20.0	31261501
UNSPSC 21.0	31261501

Approvals

Approvals

Approvals

EAC

Ex Approvals

Approval details

EAC		RU C- DE.AI30.B.01102
-----	--	--------------------------

Accessories

Accessories

Half screw connection

Screw connection - HC-COM-K-KV-PG16(9-12) SML - 1409286



Pg16 screw connection accessories for box mounting base with cable diameter 9 mm ... 12 mm

Housing - HC-COM-K-SML-O1PG16 - 1408371

Accessories

Screw connection - HC-COM-K-KV-PG16(11,5-15) SML - 1409299



Pg16 screw connection accessories for box mounting base with cable diameter 11.5 mm ... 15 mm

Phoenix Contact 2020 © - all rights reserved
<http://www.phoenixcontact.com>

PHOENIX CONTACT GmbH & Co. KG
Flachsmarktstr. 8
32825 Blomberg
Germany
Tel. +49 5235 300
Fax +49 5235 3 41200
<http://www.phoenixcontact.com>

Mouser Electronics

Authorized Distributor

Click to View Pricing, Inventory, Delivery & Lifecycle Information:

[Phoenix Contact:](#)

[1408371](#)