

Housing - HC-ADV-B10-HHWH-1TGM25-PL - 1404227

Please be informed that the data shown in this PDF Document is generated from our Online Catalog. Please find the complete data in the user's documentation. Our General Terms of Use for Downloads are valid (<http://phoenixcontact.com/download>)



Sleeve housing B10, with screw locking, material: PA, cable outlets: 1, straight, height: 95 mm, cable gland: with, support sleeve: no, 1x M25, Standard

Your advantages

- ✓ Integrated screw connection
- ✓ Lower costs than metal version
- ✓ Can also be used without panel mounting base
- ✓ Labeling option using 9 x 20 mm marking label
- ✓ Low weight
- ✓ Lower risk of condensation
- ✓ Both contact insert PE sheets are connected by means of a metal frame integrated in the sleeve housing
- ✓ Capacitive PE, even when connected at an angle
- ✓ Completely corrosion-resistant
- ✓ Halogen-free plastic
- ✓ Impact test according to IK 08



Key Commercial Data

| | |
|--------------|---------------|
| Packing unit | 1 pc |
| GTIN | |
| GTIN | 4046356681988 |

Technical data

Dimensions

| | |
|-------------------------------|----------------|
| Height | 95 mm |
| Width | 57 mm |
| Length | 105 mm |
| Wrench size, union nut | 26 mm |
| External cable diameter | 9 mm ... 17 mm |
| Length of the assembly cutout | 65 mm |

Housing - HC-ADV-B10-HHWH-1TGM25-PL - 1404227

Technical data

Dimensions

| | |
|------------------------------|-------|
| Width of the assembly cutout | 35 mm |
|------------------------------|-------|

Ambient conditions

| | |
|--------------------------------------|-------------------|
| Degree of protection of housing (IP) | IP66 |
| | IP67 |
| Ambient temperature (operation) | -40 °C ... 100 °C |

General

| | |
|--|--|
| Note | For contact inserts HC-B10, BB18, DD42, M, K8/24, HV03-I-PT, HC- 3-E...C |
| Size | B10 |
| Housing type | Sleeve housing |
| Color | black |
| Locking type | with screw locking |
| Torque | 3 Nm (Locking screw) |
| Fixing screws | M6 (screw head: 5 mm Allen screw) |
| No. of cable outlets | 1 |
| Cable outlet | straight |
| Screw connection | with |
| Type of the screw connection | 1x M25 |
| Housing material | PA |
| Seal material | NBR |
| Cable seal material | NBR |
| Material lock | Stainless steel |
| Material of locking screw | Stainless steel |
| Flammability rating according to UL 94 | V0 (Housing) |
| Assembly instructions | M6 locking screw, with 5 mm Allen screw head |

Environmental Product Compliance

| | |
|------------|---|
| China RoHS | Environmentally friendly use period: unlimited = EFUP-e |
| | No hazardous substances above threshold values |

Drawings

Housing - HC-ADV-B10-HHWH-1TGM25-PL - 1404227

Dimensional drawing

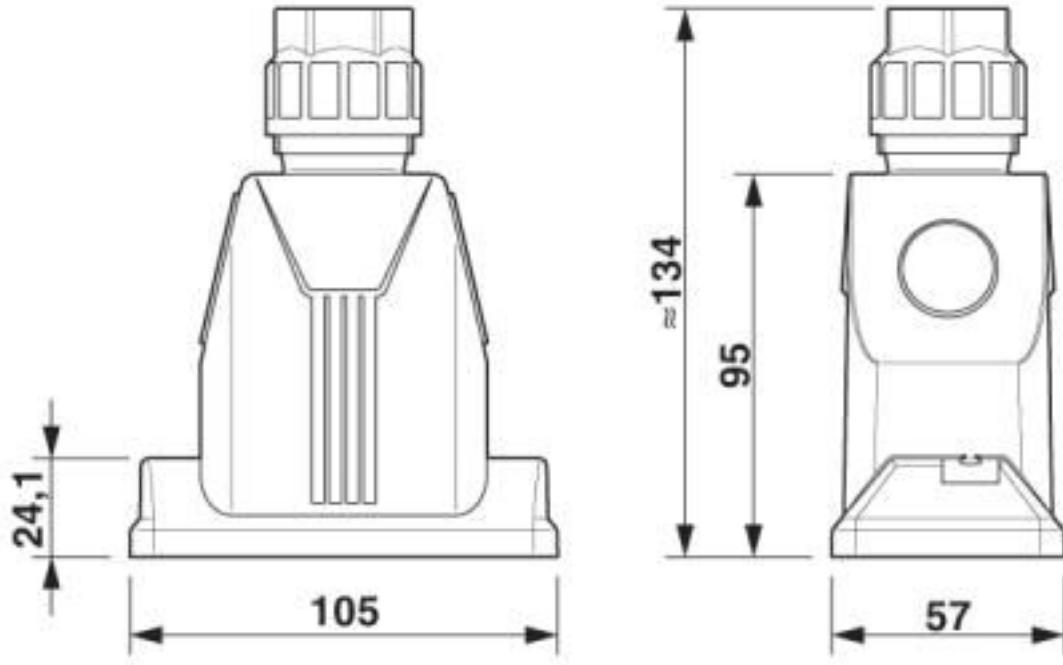

Dimensional drawing

Housing - HC-ADV-B10-HHWH-1TGM25-PL - 1404227

Dimensional drawing

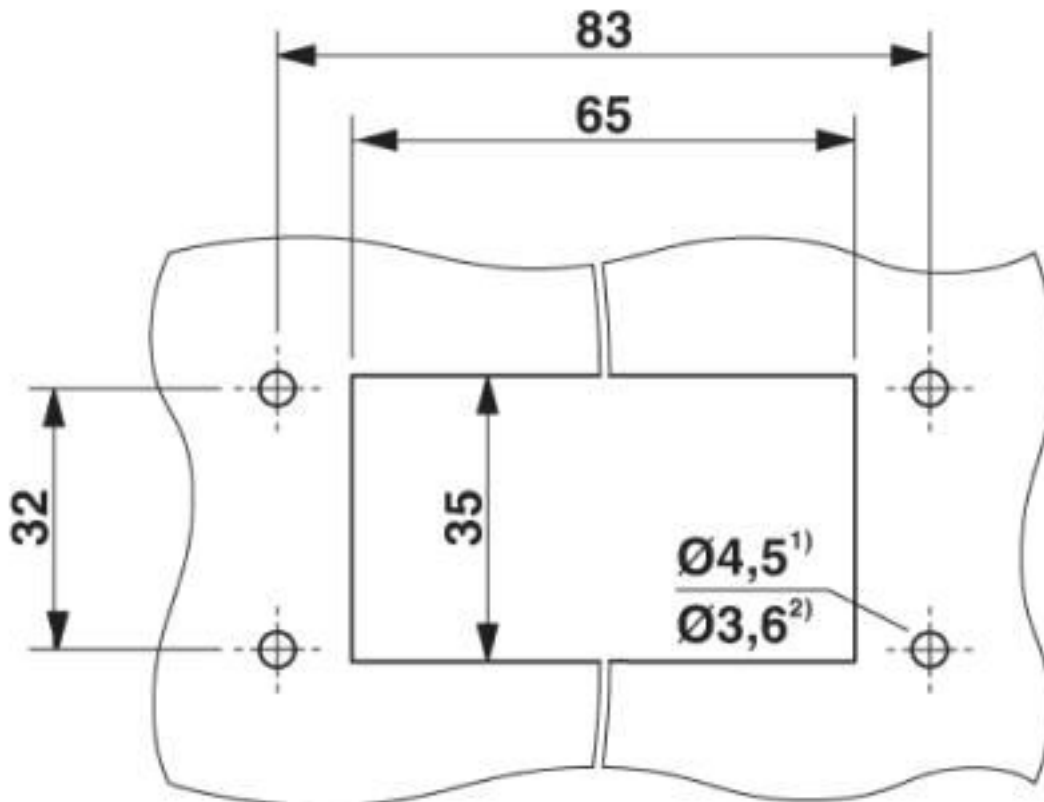

Mounting cutout

- 1) when M4 screws are used
- 2) when self-tapping Torx® screws are used (Torx® 20, M4)

Classifications

eCl@ss

| | |
|---------------|----------|
| eCl@ss 10.0.1 | 27440202 |
| eCl@ss 4.0 | 27140800 |
| eCl@ss 4.1 | 27140800 |
| eCl@ss 5.0 | 27143400 |
| eCl@ss 5.1 | 27261200 |
| eCl@ss 6.0 | 27261200 |
| eCl@ss 7.0 | 27440202 |
| eCl@ss 8.0 | 27440202 |
| eCl@ss 9.0 | 27440202 |

ETIM

| | |
|----------|----------|
| ETIM 3.0 | EC000516 |
| ETIM 4.0 | EC000437 |
| ETIM 5.0 | EC000437 |

Housing - HC-ADV-B10-HHWH-1TGM25-PL - 1404227

Classifications

ETIM

| | |
|----------|----------|
| ETIM 6.0 | EC000437 |
| ETIM 7.0 | EC000437 |

UNSPSC

| | |
|---------------|----------|
| UNSPSC 6.01 | 31261502 |
| UNSPSC 7.0901 | 31261502 |
| UNSPSC 11 | 31261502 |
| UNSPSC 12.01 | 31261502 |
| UNSPSC 13.2 | 31261501 |
| UNSPSC 18.0 | 31261501 |
| UNSPSC 19.0 | 31261501 |
| UNSPSC 20.0 | 31261501 |
| UNSPSC 21.0 | 31261501 |

Approvals

Approvals

Approvals

EAC / DNV GL

Ex Approvals

Approval details

| | | |
|-----|--|--------------------------|
| EAC | | RU C- DE.AI30.B.01102 |
|-----|--|--------------------------|

| | | | |
|--------|--|---|------------|
| DNV GL | | https://approvalfinder.dnvgl.com/ | TAE000037S |
|--------|--|---|------------|

Accessories

Accessories

Device marking

Housing - HC-ADV-B10-HHWH-1TGM25-PL - 1404227

Accessories

Snap-in markers - US-EMP (20X9) - 0829439



Snap-in markers, Card, white, unlabeled, can be labeled with: BLUEMARK ID COLOR, BLUEMARK ID, THERMOMARK PRIME, THERMOMARK CARD 2.0, THERMOMARK CARD, mounting type: snapped into marker carrier, lettering field size: 20 x 9 mm, Number of individual labels: 70

Panel mounting flange

Mounting flange - HC-B-AF - 1686533



Panel mounting flange for HEAVYCON-ADVANCE TMS housing with screw locking

Mounting flange - HC-B-AF-SET - 1604638



Panel mounting flange for screw locking, set comprising 2 panel mounting flanges with 4 self-tapping screws (M4, Torx®) and 4 fan-type washers

Screwdriver tools

Screwdriver - SF-M BH - 1212070



Bit screwdriver, with 1/4" quick-action chuck, handle length 119 mm, 2-component handle, with non-slip grip, suitable for bits according to DIN 3126-C 6.3 and E 6.3/ISO 1173, magnetic

Screwdriver - SF-BIT-HEXB 5-89 - 1208911



Screw bit, hexagonal with ball head, E6.3-1/4" drive, size: Hex 5 x 89 mm, hardened, suitable for holder according to DIN 3126-F 6.3/ISO 1173

Phoenix Contact 2020 © - all rights reserved
<http://www.phoenixcontact.com>

PHOENIX CONTACT GmbH & Co. KG
Flachmarktstr. 8
32825 Blomberg
Germany
Tel. +49 5235 300
Fax +49 5235 3 41200
<http://www.phoenixcontact.com>

Mouser Electronics

Authorized Distributor

Click to View Pricing, Inventory, Delivery & Lifecycle Information:

[Phoenix Contact:](#)

[1404227](#)