

DIN rail mounting frame - HC-CIF-B10-BFFD-FH-AL - 1404219

Please be informed that the data shown in this PDF Document is generated from our Online Catalog. Please find the complete data in the user's documentation. Our General Terms of Use for Downloads are valid (<http://phoenixcontact.com/download>)



HEAVYCON DIN rail mounting frame, lower part for double locking latch, for sleeve housing with double locking latch or HC-CIF-..HFFD..., for type B10 contact inserts, for NS35/7,5 DIN rails

Your advantages

- Sturdy metal version
- Open base, pre-assembled cable harnesses can be used
- Standardized design; both PE sheets for inserts are connected conductively
- Safe capacitive PE even when connected slightly askew



Key Commercial Data

Packing unit	1 pc
GTIN	
GTIN	4046356681919

Technical data

Dimensions

Length	93.5 mm
Width	56 mm
Height	85 mm

Ambient conditions

Ambient temperature (operation)	-40 °C ... 125 °C
---------------------------------	-------------------

General

Size	For B10
Material	Cast aluminum, uncoated
Mounting type	DIN rail: 35 mm

Environmental Product Compliance

China RoHS	Environmentally friendly use period: unlimited = EFUP-e
------------	---

DIN rail mounting frame - HC-CIF-B10-BFFD-FH-AL - 1404219

Technical data

Environmental Product Compliance

	No hazardous substances above threshold values
--	--

Drawings

Dimensional drawing

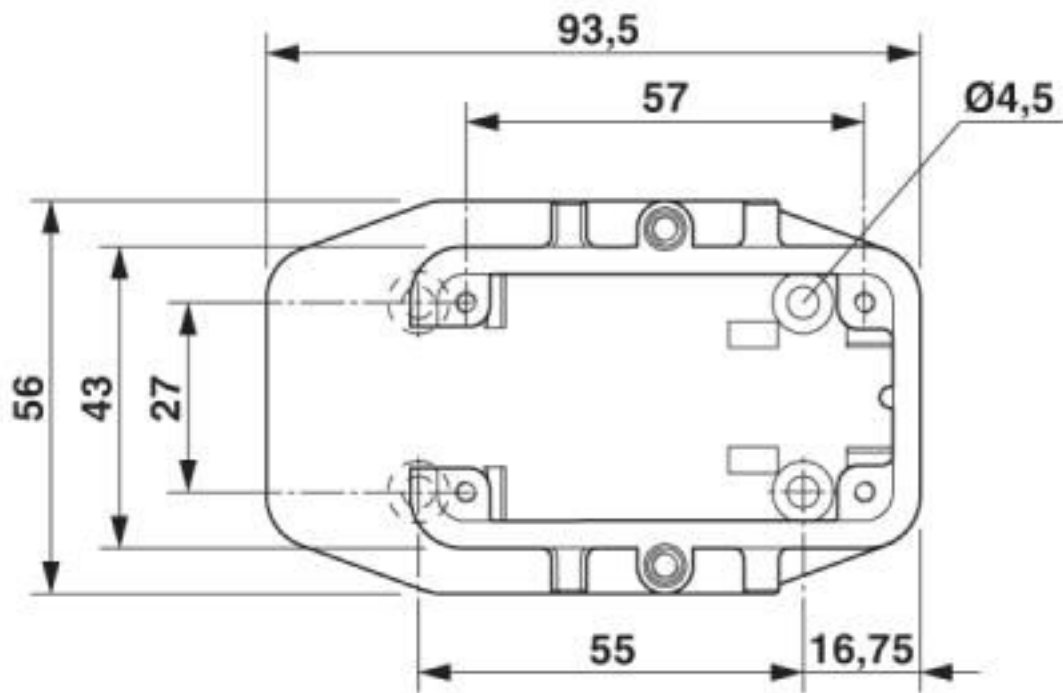

Dimensional drawing top view

DIN rail mounting frame - HC-CIF-B10-BFFD-FH-AL - 1404219

Dimensional drawing

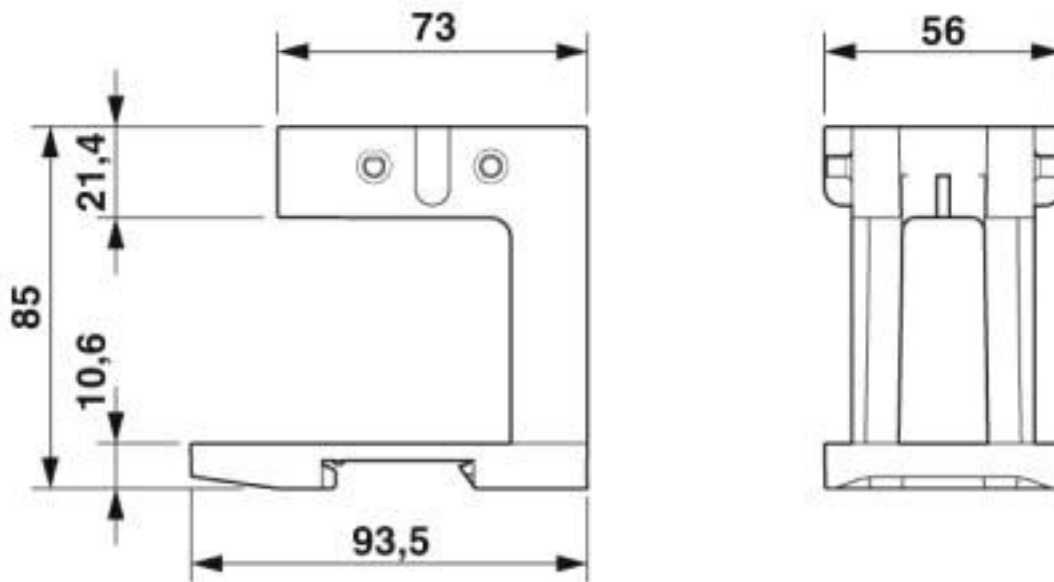

Dimensional drawing

Classifications

eCl@ss

eCl@ss 10.0.1	27440210
eCl@ss 4.0	27140800
eCl@ss 4.1	27140800
eCl@ss 5.0	27143400
eCl@ss 5.1	27143400
eCl@ss 6.0	27261200
eCl@ss 7.0	27440206
eCl@ss 8.0	27440206
eCl@ss 9.0	27440210

ETIM

ETIM 3.0	EC002310
ETIM 4.0	EC002310
ETIM 5.0	EC002310
ETIM 6.0	EC002310
ETIM 7.0	EC002310

UNSPSC

UNSPSC 6.01	43172601
UNSPSC 7.0901	39121416
UNSPSC 11	43172601

DIN rail mounting frame - HC-CIF-B10-BFFD-FH-AL - 1404219

Classifications

UNSPSC

UNSPSC 12.01	39121408
UNSPSC 13.2	39121421
UNSPSC 18.0	39121421
UNSPSC 19.0	39121421
UNSPSC 20.0	39121421
UNSPSC 21.0	39121421

Approvals

Approvals

Approvals

EAC

Ex Approvals

Approval details

EAC		RU C- DE.AI30.B.01102
-----	--	--------------------------

Accessories

Additional products

DIN rail mounting frame - HC-CIF-B10-HFFD-WH-AL - 1404221



HEAVYCON DIN rail mounting frame, upper part for double locking latch, for HC-CIF...BFWD.. lower parts with double locking latch or for HC-CIF...BFFD.. lower parts, for type B10 contact inserts, with M4 screws with 3 mm Allen screw head, for NS35/7,5 DIN rails

Phoenix Contact 2020 © - all rights reserved
<http://www.phoenixcontact.com>

PHOENIX CONTACT GmbH & Co. KG
Flachmarktstr. 8
32825 Blomberg
Germany
Tel. +49 5235 300
Fax +49 5235 3 41200
<http://www.phoenixcontact.com>

Mouser Electronics

Authorized Distributor

Click to View Pricing, Inventory, Delivery & Lifecycle Information:

[Phoenix Contact:](#)

[1404219](#)