

## Network cable - VS-M12FSBP-OE-94B-LI/0,5 - 1401057

Please be informed that the data shown in this PDF Document is generated from our Online Catalog. Please find the complete data in the user's documentation. Our General Terms of Use for Downloads are valid (<http://phoenixcontact.com/download>)



Assembled Ethernet cable, shielded, 4-pair, AWG 26 stranded (7-wire), RAL 5021 (sea blue), M12 flush-type socket, rear wall/screw mounting with M16 thread on free cable end, line, length 0.5 m

### Your advantages

- Pre-assembled with cables in various standard lengths for immediate use
- Customer-specific assemblies and cable lengths can be supplied
- Sealed on the cable side for optimum tightness of seal
- Cable designs for all common networks and fieldbuses
- For high transmission safety: shield connection to the housing with optional EMC nut



Ethernet

### Key Commercial Data

Packing unit	1 pc
Minimum order quantity	50 pc
GTIN	 4 046356 520942
GTIN	4046356520942

### Technical data

#### Mechanical characteristics

Overvoltage category	II
Degree of pollution	3
Cable outlet	straight
No. of cable outlets	1
Weight	47.7 g
Flammability rating according to UL 94	V0

#### Ambient conditions

Ambient temperature (operation)	-25 °C ... 85 °C (Plug / socket)
	-40 °C ... 85 °C (without mechanical actuation)
	-25 °C ... 85 °C (cable, flexible installation)

## Network cable - VS-M12FSBP-OE-94B-LI/0,5 - 1401057

### Technical data

#### Ambient conditions

	-40 °C ... 85 °C (cable, fixed installation)
Degree of protection	IP67 (When plugged in)
	IP65 (When plugged in)

#### Material data

Contact surface material	Ni/Au
Contact material	CuZn

#### Electrical characteristics

Transmission speed	1 Gbps
Resistance	100 MΩ

#### Standards and Regulations

Flammability rating according to UL 94	V0
--	----

#### Environmental Product Compliance

REACH SVHC	Lead 7439-92-1
China RoHS	Environmentally Friendly Use Period = 50 years
	For details about hazardous substances go to tab "Downloads", Category "Manufacturer's declaration"

### Drawings

# Network cable - VS-M12FSBP-OE-94B-LI/0,5 - 1401057

Schematic diagram

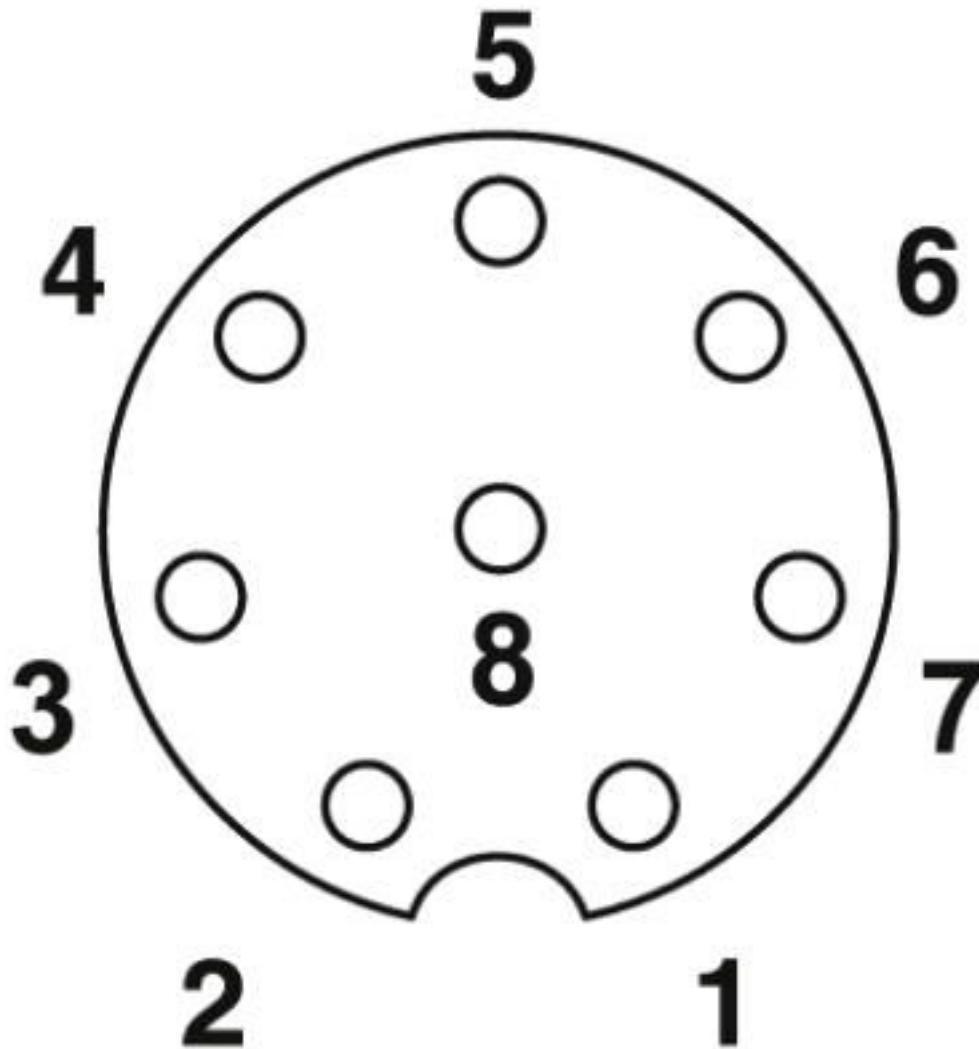

Pin assignment M12 socket, 8-pos., A-coded, view female side

# Network cable - VS-M12FSBP-OE-94B-LI/0,5 - 1401057

Dimensional drawing

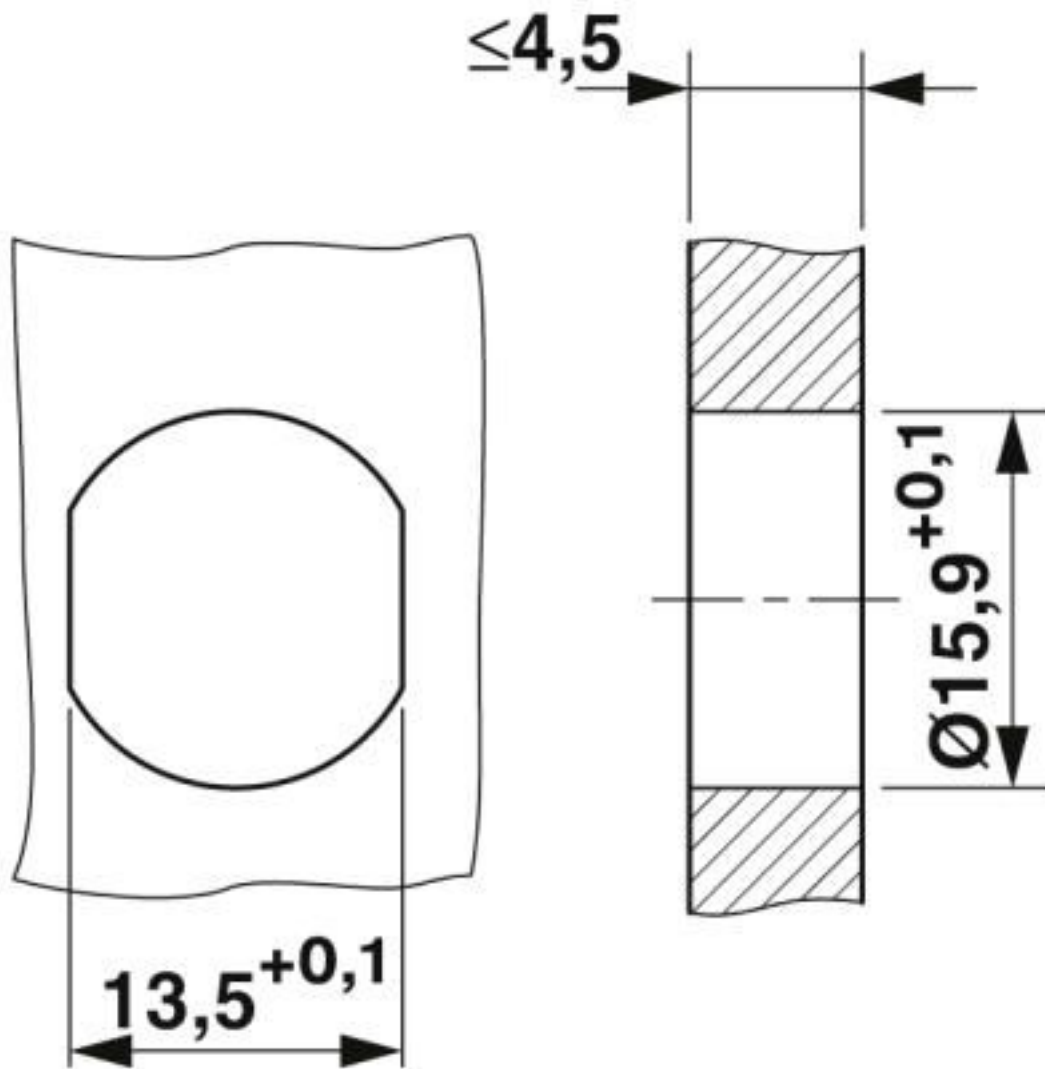

Housing cutout for M16 fastening thread, mounting panel with feed-through hole (alternatively with surface as protection against rotation)

# Network cable - VS-M12FSBP-OE-94B-LI/0,5 - 1401057

Dimensional drawing

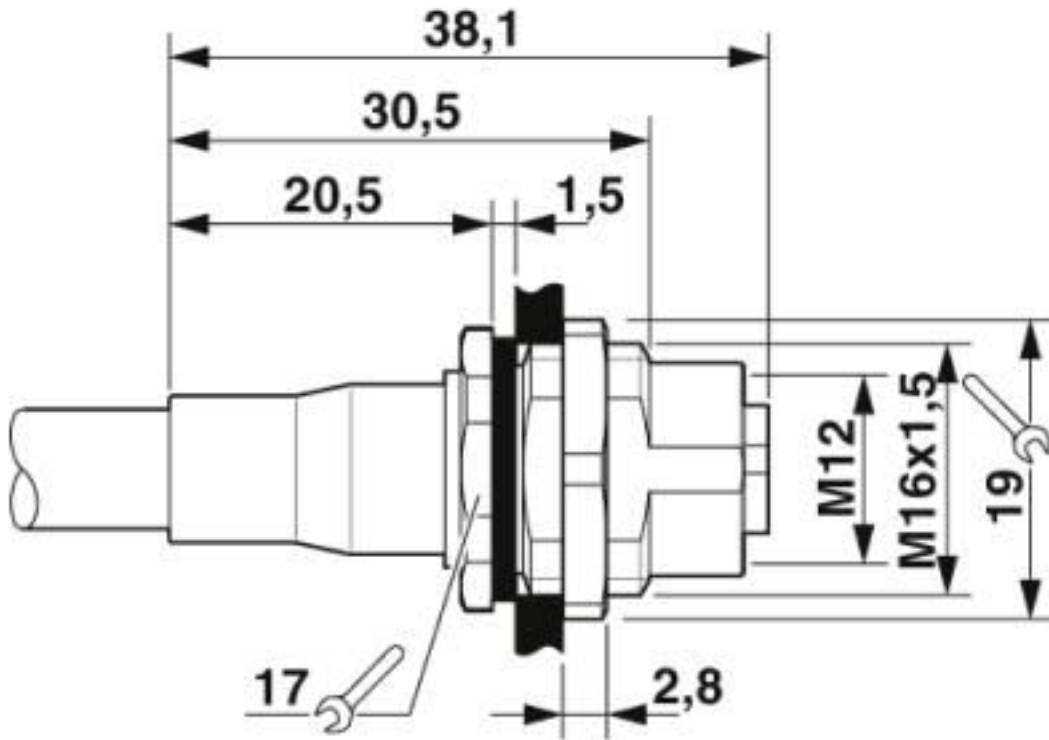

M12 flush-type connector

# Network cable - VS-M12FSBP-OE-94B-LI/0,5 - 1401057

Circuit diagram

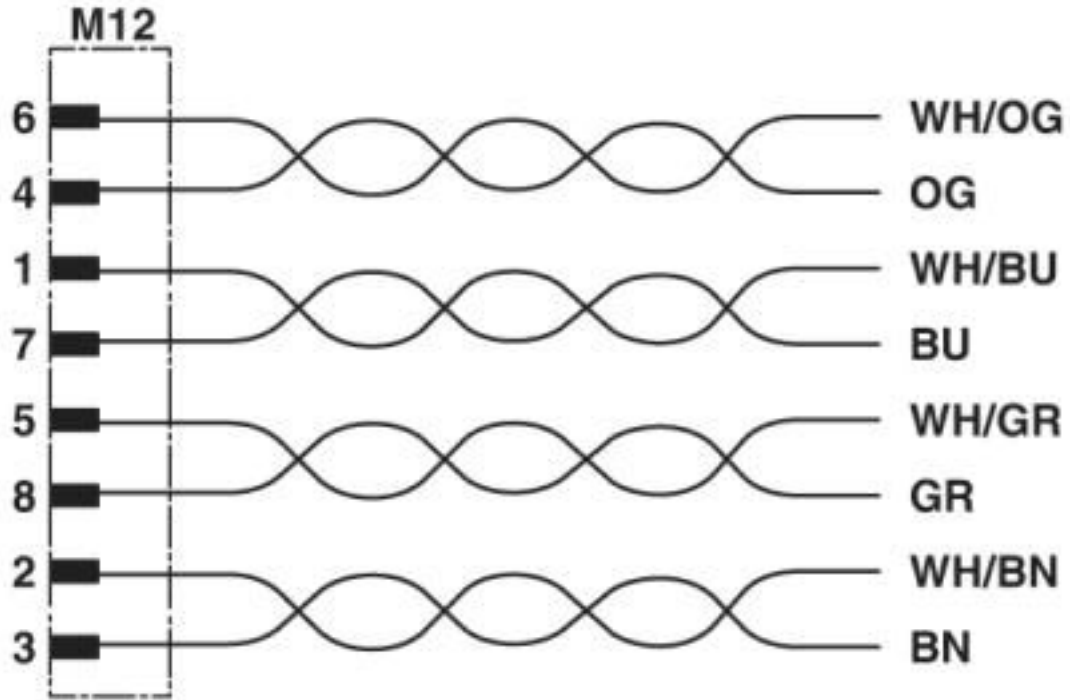

Contact assignment of the M12 plug and the M12 socket

# Network cable - VS-M12FSBP-OE-94B-LI/0,5 - 1401057

Cable cross section



Ethernet flexible CAT5, 4-pair [94B]

## Classifications

eCl@ss

eCl@ss 10.0.1	27060311
eCl@ss 4.0	27060300
eCl@ss 4.1	27060300
eCl@ss 5.0	27060300
eCl@ss 5.1	27060300
eCl@ss 6.0	27279200
eCl@ss 7.0	27279218
eCl@ss 8.0	27279218
eCl@ss 9.0	27060311

# Network cable - VS-M12FSBP-OE-94B-LI/0,5 - 1401057

## Classifications

### ETIM

ETIM 3.0	EC000830
ETIM 4.0	EC002599
ETIM 5.0	EC001855
ETIM 6.0	EC001855
ETIM 7.0	EC001855

### UNSPSC

UNSPSC 6.01	26121616
UNSPSC 7.0901	26121616
UNSPSC 11	26121604
UNSPSC 12.01	31261501
UNSPSC 13.2	31251501
UNSPSC 19.0	31251501
UNSPSC 20.0	31251501
UNSPSC 21.0	31251501

## Approvals

### Approvals

---

Approvals

EAC

---

Ex Approvals

---

### Approval details

EAC		19060508
-----	--	----------

---

Phoenix Contact 2020 © - all rights reserved  
<http://www.phoenixcontact.com>

PHOENIX CONTACT GmbH & Co. KG  
Flachsmarktstr. 8  
32825 Blomberg  
Germany  
Tel. +49 5235 300  
Fax +49 5235 3 41200  
<http://www.phoenixcontact.com>



# Mouser Electronics

Authorized Distributor

Click to View Pricing, Inventory, Delivery & Lifecycle Information:

[Phoenix Contact:](#)

[1401057](#)