

Snap-on frame - CES-B24-SF-PLBK - 0801647

Please be informed that the data shown in this PDF Document is generated from our Online Catalog. Please find the complete data in the user's documentation. Our General Terms of Use for Downloads are valid (<http://phoenixcontact.com/download>)



Snap-on frame, type: B24, length: 155 mm, width: 64 mm, height: 39 mm, color: black

Your advantages

- ✔ Can also be used for standard panel cutouts for heavy-duty industrial connectors

Key Commercial Data

Packing unit	1 pc
GTIN	 4 046356 674577
GTIN	4046356674577

Technical data

Dimensions

Length	155 mm
Width	64 mm
Height	39 mm

Ambient conditions

Degree of protection	IP54
Ambient temperature (operation)	-20 °C ... 80 °C (static)

General

Frame type	Snap-on frame
Material	PA (halogen-free)
Flammability rating according to UL 94	V0
Color	black
Note	Mounting screws not supplied as standard. The maximum width of the panel cutout must not exceed 51 mm (instead of 35 mm for heavy-duty industrial connectors).
Installation instructions	M4 mounting screw, 1.8 Nm torque.

Snap-on frame - CES-B24-SF-PLBK - 0801647

Technical data

General

	A video tutorial on how to assemble the product can be found in the Downloads area, in the Video category.
--	--

Standards and Regulations

Flammability rating according to UL 94	V0
--	----

Environmental Product Compliance

China RoHS	Environmentally friendly use period: unlimited = EFUP-e
	No hazardous substances above threshold values

Drawings

Dimensional drawing

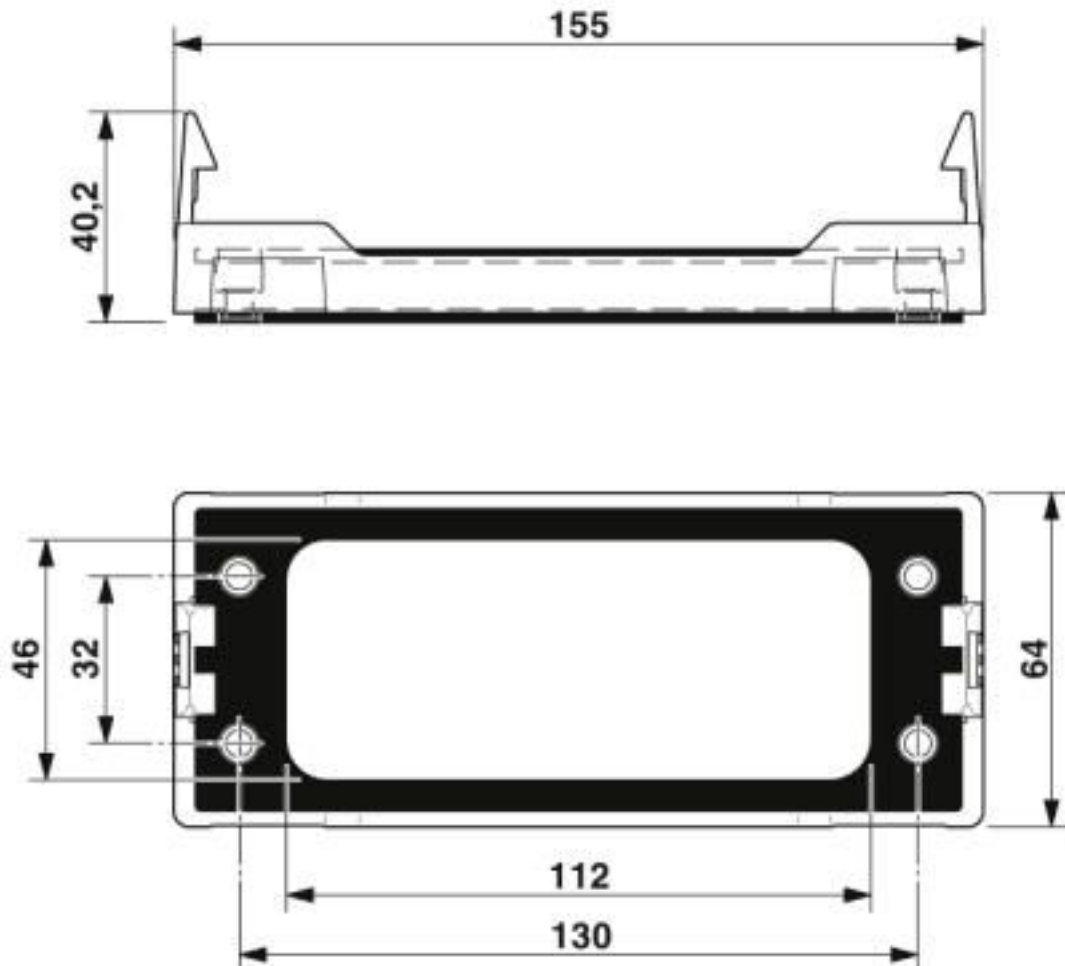

Dimensional drawing

Snap-on frame - CES-B24-SF-PLBK - 0801647

Dimensional drawing

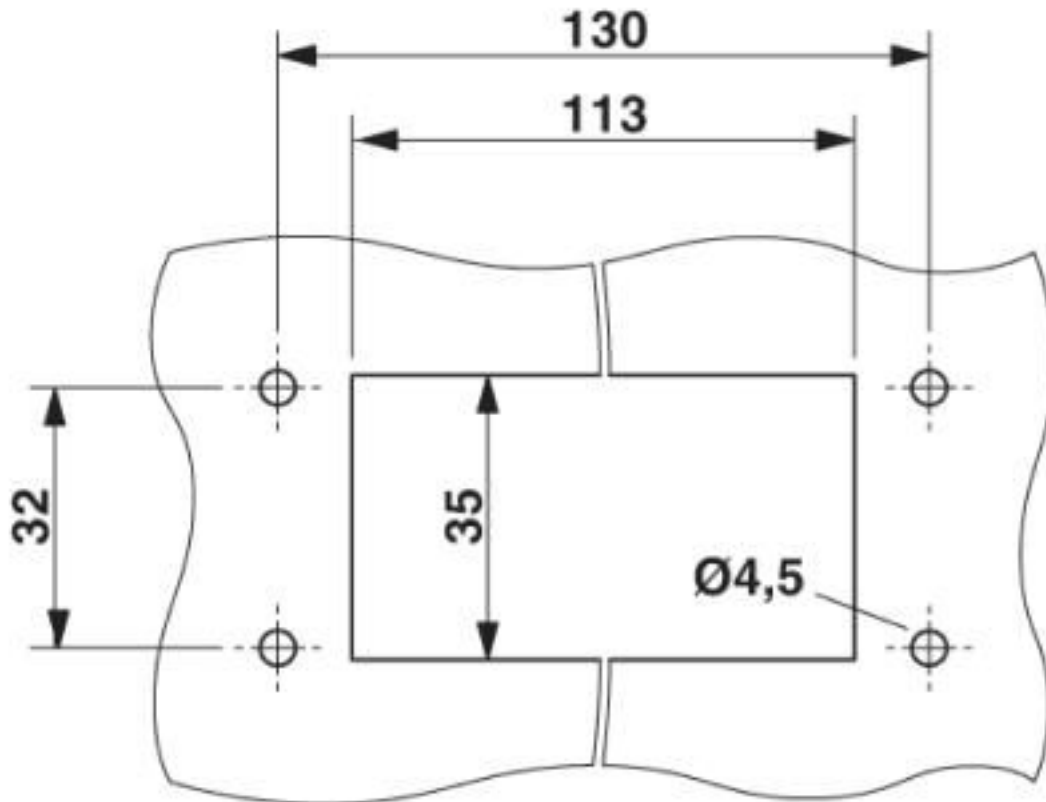

Mounting cutout

Classifications

eCl@ss

eCl@ss 10.0.1	27440192
eCl@ss 4.0	27081000
eCl@ss 4.1	27081000
eCl@ss 5.0	27081000
eCl@ss 5.1	27081000
eCl@ss 6.0	27081000
eCl@ss 7.0	27069220
eCl@ss 8.0	27069220
eCl@ss 9.0	27440192

ETIM

ETIM 3.0	EC000451
ETIM 4.0	EC000451
ETIM 5.0	EC000451
ETIM 6.0	EC000451

Snap-on frame - CES-B24-SF-PLBK - 0801647

Classifications

ETIM

ETIM 7.0	EC000451
----------	----------

UNSPSC

UNSPSC 6.01	30212109
UNSPSC 7.0901	39121708
UNSPSC 11	39121708
UNSPSC 12.01	39121708
UNSPSC 13.2	39121448
UNSPSC 18.0	39121421
UNSPSC 19.0	39121421
UNSPSC 20.0	39121421
UNSPSC 21.0	39121421

Approvals

Approvals

Approvals

DNV GL

Ex Approvals

Approval details

DNV GL		https://approvalfinder.dnvgl.com/	TAE00003VJ
--------	---	---	------------

Accessories

Accessories

Cover plate

Locking element - CES-B24-SFC-M-15,6 - 1423745



Locking element, type: B24, length: 146 mm, width: 57 mm, height: 17 mm

Frame for cable sleeves

Snap-on frame - CES-B24-SF-PLBK - 0801647

Accessories

Sealing frame - CES-B24-HFFS-PLBK - 0801661



Sealing frame with locking latch, size B24, with flat gasket, for 10 small sleeves

Sealing frame - CES-B24-SFFS-PLBK - 0801658



Sealing frame with screw locking, size B24, with flat gasket, for 10 small sleeves

Phoenix Contact 2020 © - all rights reserved
<http://www.phoenixcontact.com>

PHOENIX CONTACT GmbH & Co. KG
Flachsmarktstr. 8
32825 Blomberg
Germany
Tel. +49 5235 300
Fax +49 5235 3 41200
<http://www.phoenixcontact.com>

Mouser Electronics

Authorized Distributor

Click to View Pricing, Inventory, Delivery & Lifecycle Information:

[Phoenix Contact:](#)

[0801647](#)