

Electronic housing - EG 90-G/ABS GN - 2764328

Please be informed that the data shown in this PDF Document is generated from our Online Catalog. Please find the complete data in the user's documentation. Our General Terms of Use for Downloads are valid (<http://phoenixcontact.com/download>)



Lower housing part, with snap-on foot

The figure shows a fully mounted version of the electronic housing

Your advantages

- ✓ Tool-free mounting
- ✓ Optimum accommodation of electronic components with graded pitches with a design width of 22.5 mm, 45 mm, 67.5 mm, and 90 mm
- ✓ Functional and industry-oriented housing technology
- ✓ Practical and easy-to-wire conductor connection using extra finely stranded sturdy screw terminal blocks up to 2.5 mm²
- ✓ Date of manufacture and material and part identification embossed on the housing (recyclability)
- ✓ Fast snap-on mounting on symmetrical DIN rails according to EN 60715
- ✓ Shock and contamination-proof accommodation of electronic components (IP40 housing, IP20 terminal blocks)



Key Commercial Data

Packing unit	10 pc
GTIN	 4 017918 099510
GTIN	4017918099510

Technical data

General

Housing type	Component housing
Housing material	Acryl butadiene styrene (ABS)
Color (RAL)	green

Ambient conditions

Ambient temperature (operation)	-40 °C ... 80 °C
---------------------------------	------------------

Dimensions

Length	75 mm
--------	-------

Electronic housing - EG 90-G/ABS GN - 2764328

Technical data

Dimensions

Height	107.5 mm
Width	90 mm
Depth	75 mm

Technical data

Power dissipation without gap	6 W
Power dissipation with 20 mm gap	9.1 W
Number of positions	34

Standards and Regulations

Flammability rating according to UL 94	HB
--	----

Environmental Product Compliance

China RoHS	Environmentally friendly use period: unlimited = EFUP-e
	No hazardous substances above threshold values

Drawings

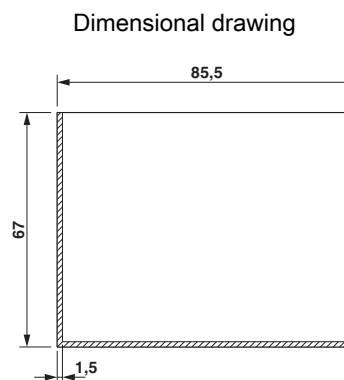
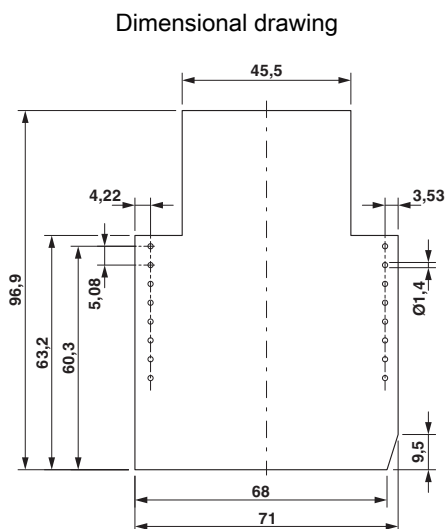

valid for PCB 1; 2; 3; 4; 5 und 6, see explosion drawing

Component mounting side, if the double-level upper part is used

Electronic housing - EG 90-G/ABS GN - 2764328

Dimensional drawing

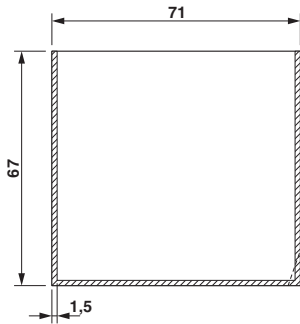

valid for PCB 7; 8; 11 and 12, see explosion drawing

Dimensional drawing

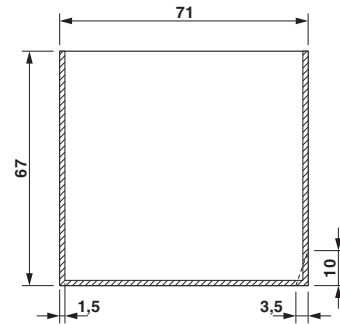

valid for PCB 9 and 10, see explosion drawing

Dimensional drawing

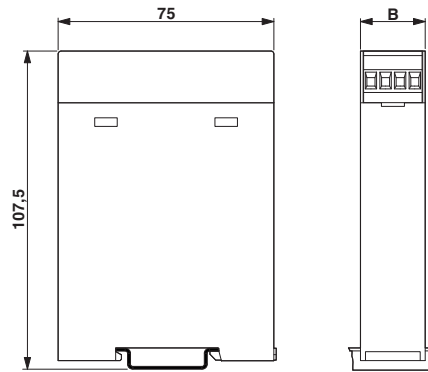

Approvals

Approvals

Approvals

UL Recognized

Ex Approvals

Approval details

UL Recognized



<http://database.ul.com/cgi-bin/XYV/template/LISEXT/1FRAME/index.htm>

FILE E 240868

Phoenix Contact 2018 © - all rights reserved
<http://www.phoenixcontact.com>

PHOENIX CONTACT GmbH & Co. KG
Flachsmarktstr. 8
32825 Blomberg
Germany
Tel. +49 5235 300
Fax +49 5235 3 41200
<http://www.phoenixcontact.com>

Mouser Electronics

Authorized Distributor

Click to View Pricing, Inventory, Delivery & Lifecycle Information:

[Phoenix Contact:](#)

[2764328](#)