

2

1

THIS COPY IS PROVIDED ON A RESTRICTED BASIS AND IS NOT TO BE USED IN ANY WAY DETRIMENTAL TO THE INTERESTS OF PANDUIT CORP.

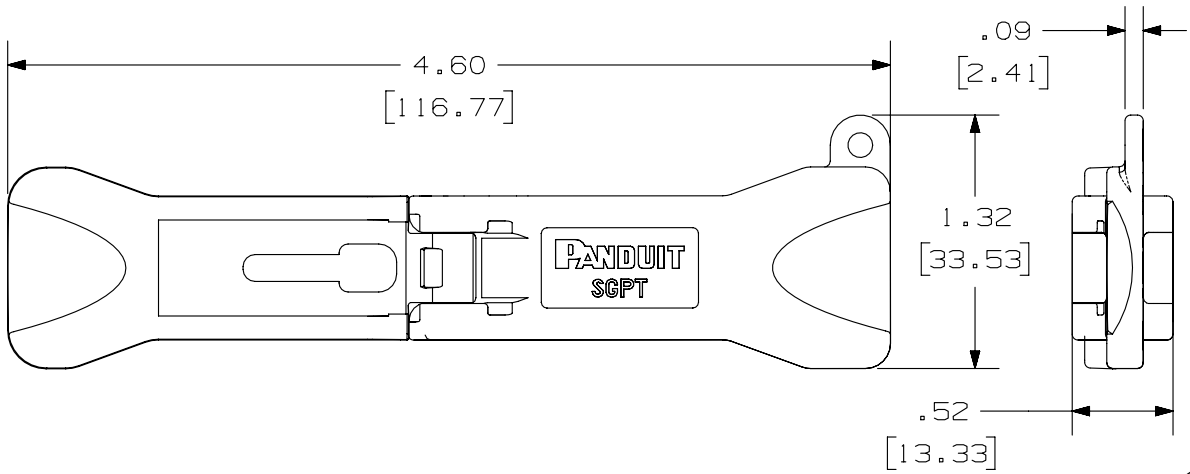

PANDUIT PART#	WEIGHT
SGPT	.28 LB/10 PCS (127 g/10 PCS)

- NOTES:
1. ASSEMBLY TOOL FOR SMALL GAUGE (28/30 AWG) CAT5E AND CAT6 PLUGS.
 2. SEE CATALOG FOR COMPLETE LIST OF SMALL GAUGE PRODUCTS.
 3. DIMENSIONS IN BRACKETS ARE IN METRIC.
 4. MATERIAL: 20% GLASS FILLED NYLON.

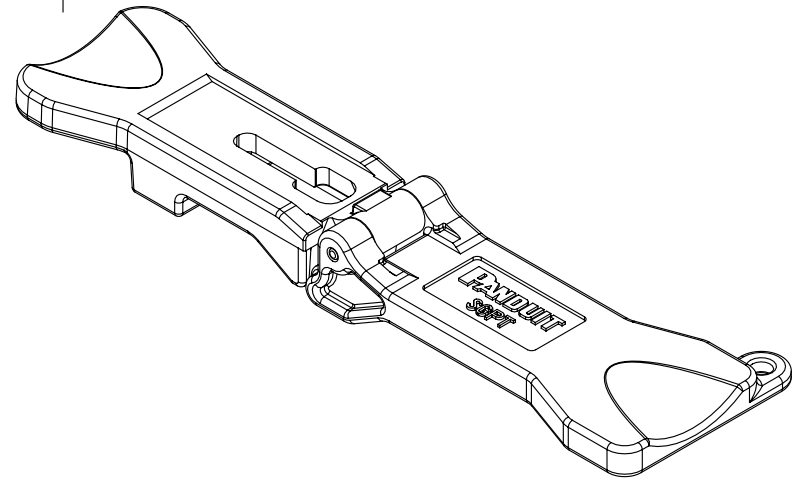
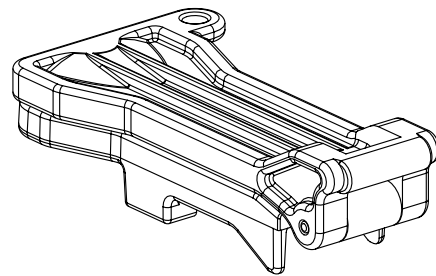
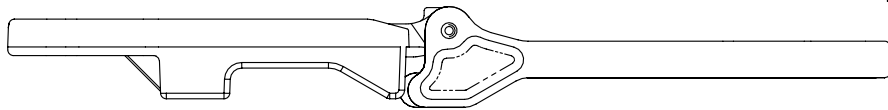

PART NUMBER		SGPT	
TITLE			
SMALL GAUGE (28/30AWG) MODULAR PLUG ASSEMBLY TOOL			
CUSTOMER DRAWING			
ITEM REVISION NAME		11M297AB/00	
DATASET FILE NAME		11M297AB_DC03/00B	
UNLESS OTHERWISE SPECIFIED, DIMENSIONAL TOLERANCES ARE: IN [mm]		MATERIAL:	
.x ± .xxx ± .010 [.3]		SEE NOTES	
.xx ± .03 [.8]		DRAWING NUMBER:	
ANGLES ±		11M297AB-03	
THIRD ANGLE PROJECTION		SHT 1 OF 1	
DRAWN BY	DATE	CHK	SCALE
LZ	11-30-11	LZ	FULL
REV	DATE	BY	CHK
1	4-30-14	BJN	JSP
APR	DESCRIPTION		ECN
	REVISED & REDRAWN PREVIOUS REVISIONS REMVD FOR CLARITY		11M297AB-03

D10100DA/14

2

1

Mouser Electronics

Authorized Distributor

Click to View Pricing, Inventory, Delivery & Lifecycle Information:

[Panduit:](#)

[SGPT](#)