

THIS COPY IS PROVIDED ON A RESTRICTED BASIS AND IS NOT TO BE USED IN ANY WAY DETRIMENTAL TO THE INTERESTS OF PANDUIT CORP.

PANDUIT P/N	WEIGHT
CFKE2A6U6J	1.03 LB/10 PCS (467.2 g/10 PCS)

NOTES:

1. SEE CURRENT CATALOG FOR ADDITIONAL PART NUMBER SUFFIXES TO INDICATE COLOR AND OR PACKAGE QUANTITY.
2. SEE CATALOG FOR COMPLETE LIST OF PARTS APPLICABLE FOR USE WITH THIS PART.
3. DIMENSIONS IN [] ARE IN METRIC.
4. PART INCLUDES:
 - 1- FACEPLATE (IW)
 - 2- LABEL
 - 2- LABEL COVER
 - 2- MOUNTING SCREW
 - 1- MINI-COM TX6 PLUS JACK MODULE (CJ688TGBU)
 - 1- MINI-COM TX6 PLUS JACK MODULE (CJ688TGOR)

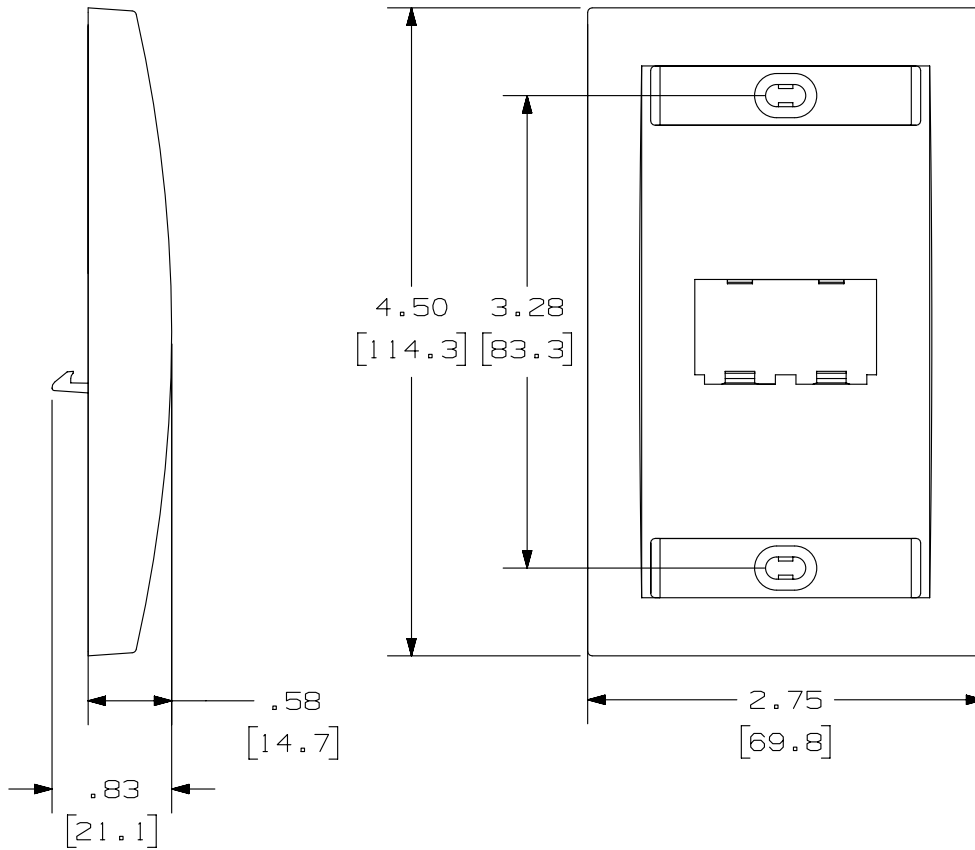

PART NUMBER		CFKE2A6U6J	
TITLE		MINI-COM 2 POSITION EXECUTIVE SERIES FACEPLATE KIT	
		CUSTOMER DRAWING	
ITEM REVISION NAME		M00741ND/00	
DATASET FILE NAME		M00741ND_DC122/00B	
UNLESS OTHERWISE SPECIFIED, DIMENSIONAL TOLERANCES ARE: IN [mm]		MATERIAL:	
.x ± .xxx ± .010 [.3] .xx ± .03 [.8]		ABS	
ANGLES ±		DRAWING NUMBER:	
THIRD ANGLE PROJECTION		00741-122	
DRAWN BY	DATE	CHK	SCALE
JSP	10-4-06	MJD	NONE
REV	DATE	BY	CHK
APR	DESCRIPTION		ECN
SHT 1 OF 1			SIZE
A			A

D10100DA/14

Mouser Electronics

Authorized Distributor

Click to View Pricing, Inventory, Delivery & Lifecycle Information:

[Panduit:](#)

[CFKE2A6U6J](#)