

THIS COPY IS PROVIDED ON A RESTRICTED BASIS AND IS NOT TO BE USED IN ANY WAY DETRIMENTAL TO THE INTERESTS OF PANDUIT CORP.

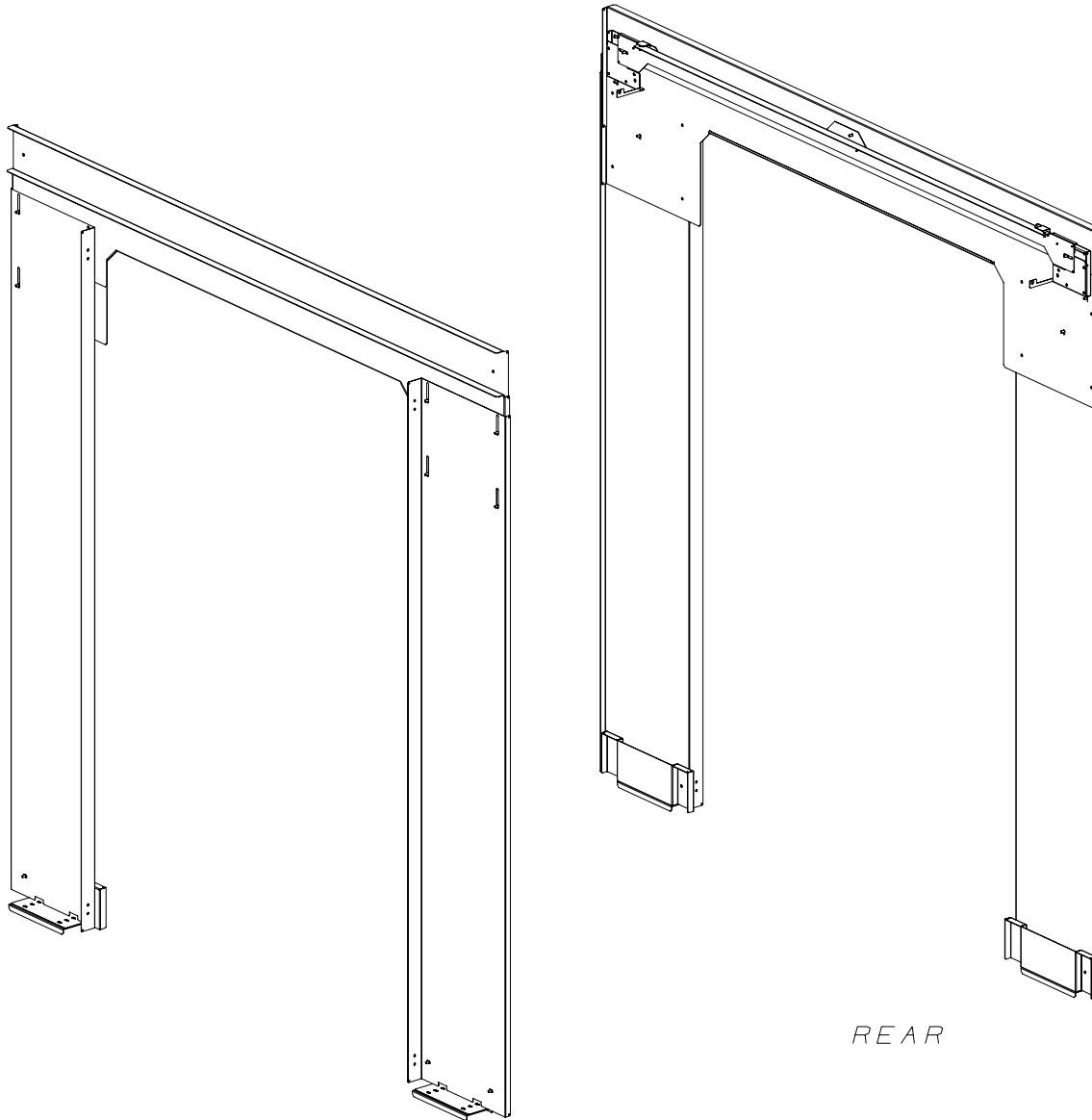

FRONT

REAR

NOTES:

1. VISIT OUR ONLINE CATALOG AT WWW.PANDUIT.COM FOR A LIST OF CURRENT PARTS APPLICABLE FOR USE WITH THIS PRODUCT.
2. PARTS SUPPLIED:
 - 1 - AISLE BEAM ASSY
 - 1 - CABINET BRACKET ASSY RH
 - 1 - CABINET BRACKET ASSY LH
 - 1 - TRANSOM 42/45
 - 1 - 3RU EXTENDER
 - 1 - DOOR MOUNTING RAIL RH
 - 1 - DOOR MOUNTING RAIL LH
 - 2 - FOOT FLOOR MOUNT
 - 2 - UNDERFLOOR PLATE
 - 1 - HARDWARE KIT (NOT SHOWN)
 - 1 - INSTRUCTION SHEET
3. PRIMARY DIMENSIONS ARE IN MILLIMETERS.

PART NO.	WEIGHT
C2SDT8W06DA**	35.1 kg 77.4 lb

** DENOTES COLOR - ADD SUFFIX:
"B1" FOR BLACK, "W1" FOR WHITE.

TITLE		1800 CAC DOOR ADAPTER 42/45 (C2SDT8W06DA**)	
ITEM REVISION NAME		15V530FE/00	
DATASET FILE NAME		15V530FE_DC/00A	
MATERIAL:		N/A	
DRAWING NUMBER:		15V530FE - DC	
DRAWN BY	DATE	CHK	SCALE
MES	6/13/16	PATR	NONE
SHT 1 OF 3			SIZE A

00A	6/13/16	MES	PATR	PATR	RELEASED TO PRODUCTION	V09000QZ/02
REV	DATE	BY	CHK	APR	DESCRIPTION	ECN

D10100DA/16

2

1

2

1

THIS COPY IS PROVIDED ON A RESTRICTED BASIS AND IS NOT TO BE USED IN ANY WAY DETRIMENTAL TO THE INTERESTS OF PANDUIT CORP.

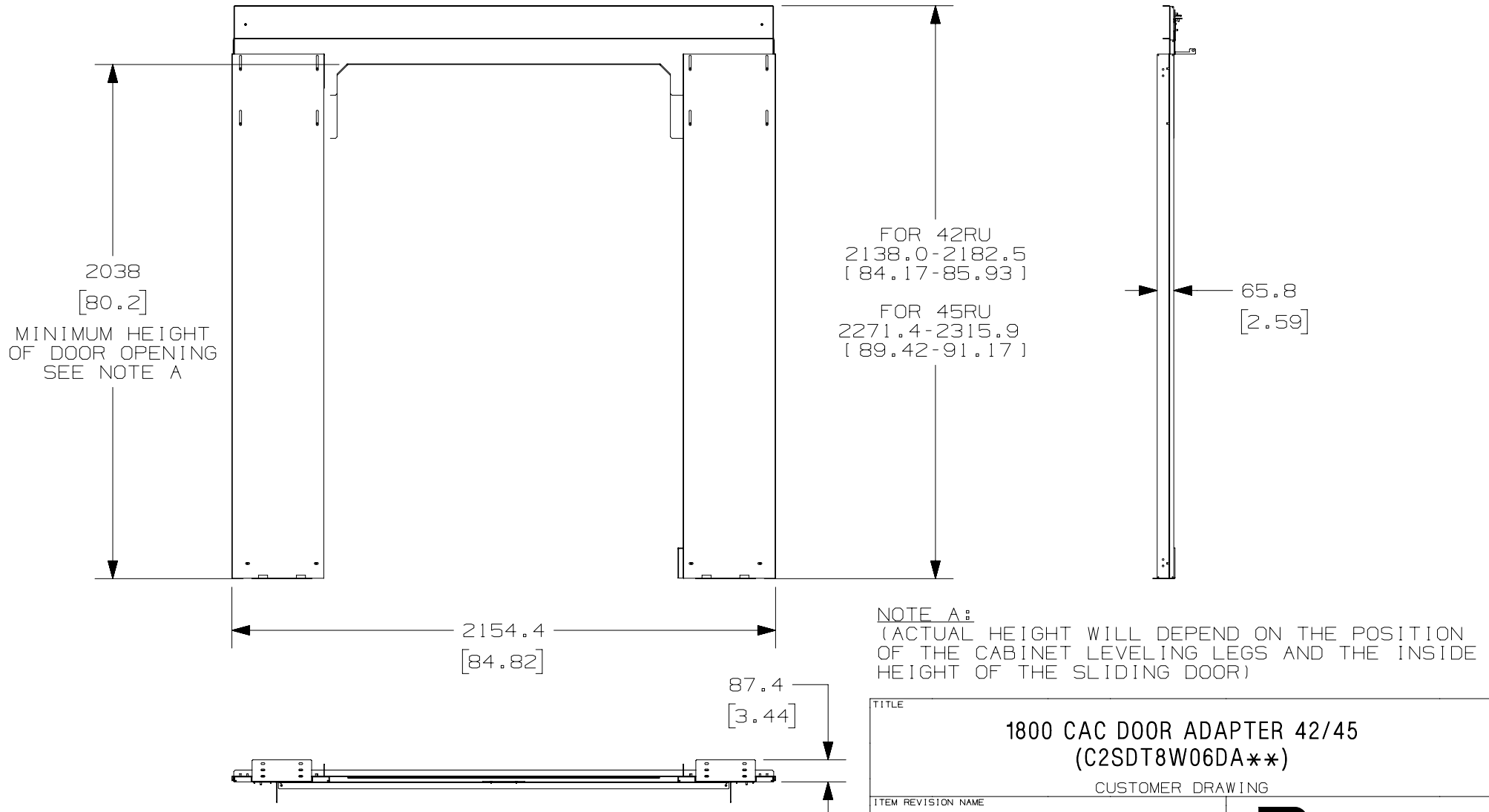

TITLE		1800 CAC DOOR ADAPTER 42/45 (C2SDT8W06DA**)	
ITEM REVISION NAME		15V530FE/00	
DATASET FILE NAME		15V530FE_DC/00A	
MATERIAL:		N/A	
DRAWING NUMBER:		15V530FE - DC	

REV	DATE	BY	CHK	APR	DESCRIPTION	ECN
00A	6/13/16	MES	PATR	PATR	SEE SHEET 1 OF 3 FOR REVISIONS	V09000QZ/02

DRAWN BY	DATE	CHK	SCALE	SHT 2 OF 3	SIZE
MES	6/13/16	PATR	NONE		A

D10100DA/16

THIS COPY IS PROVIDED ON A RESTRICTED BASIS AND IS NOT TO BE USED IN ANY WAY DETRIMENTAL TO THE INTERESTS OF PANDUIT CORP.

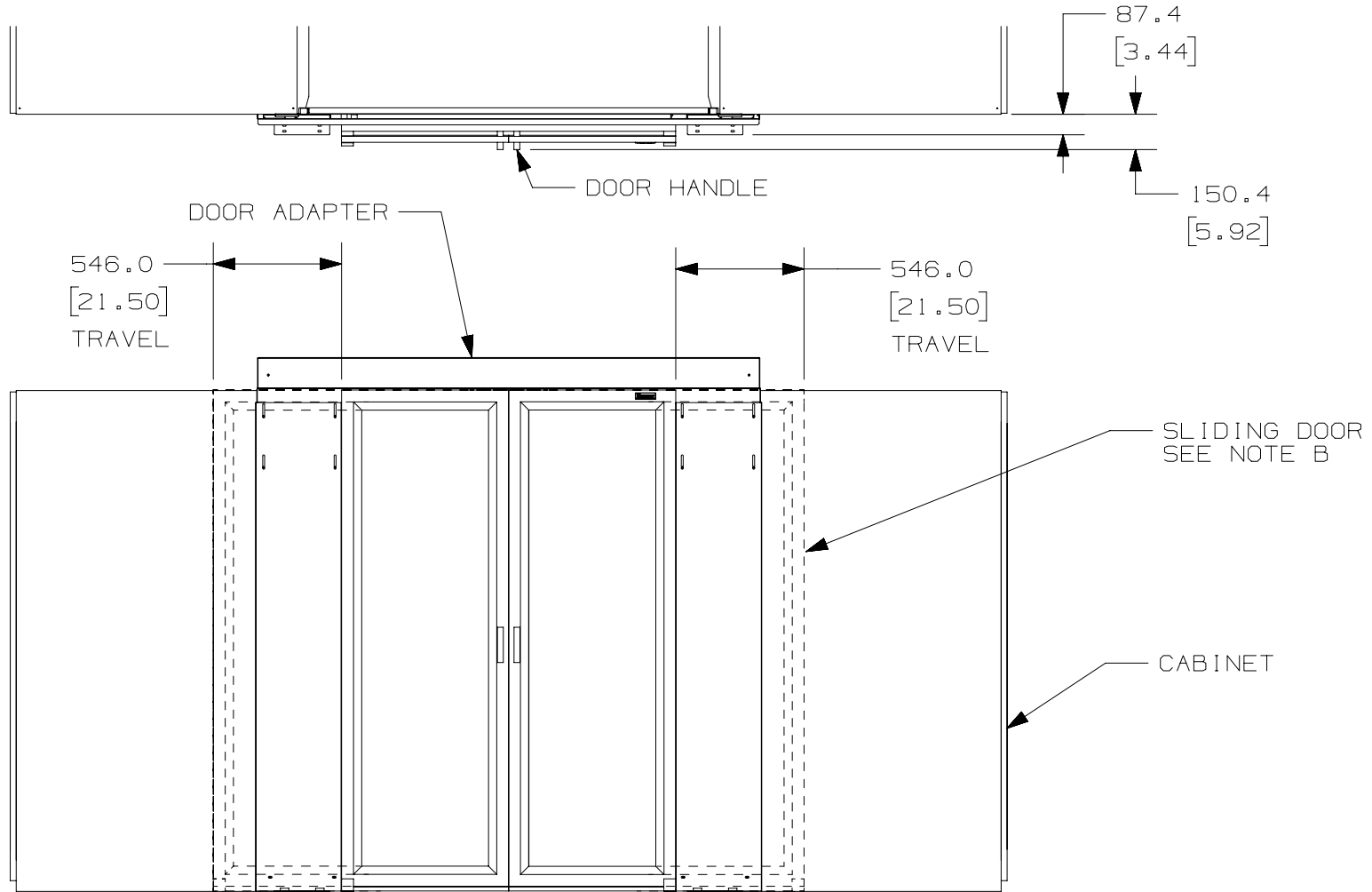

NOTE_B:
 (REFER TO THE SLIDING DOOR CUSTOMER DRAWING
 FOR THE HEIGHT AND WIDTH OF THE DOOR OPENING)

TITLE		1800 CAC DOOR ADAPTER 42/45 (C2SDT8W06DA**)	
ITEM REVISION NAME		15V530FE/00	
DATASET FILE NAME		15V530FE_DC/00A	
MATERIAL:		N/A	
DRAWING NUMBER:		15V530FE - DC	
DRAWN BY	DATE	CHK	SCALE
MES	6/13/16	PATR	NONE
SHT 3 OF 3			SIZE A

00A	6/13/16	MES	PATR	PATR	SEE SHEET 1 OF 3 FOR REVISIONS	V09000QZ/02
REV	DATE	BY	CHK	APR	DESCRIPTION	ECN

D10100DA/16

Mouser Electronics

Authorized Distributor

Click to View Pricing, Inventory, Delivery & Lifecycle Information:

[Panduit:](#)

[C2SDT8W06DAW1](#)