

THIS COPY IS PROVIDED ON A RESTRICTED BASIS AND IS NOT TO BE USED IN ANY WAY DETRIMENTAL TO THE INTERESTS OF PANDUIT CORP.

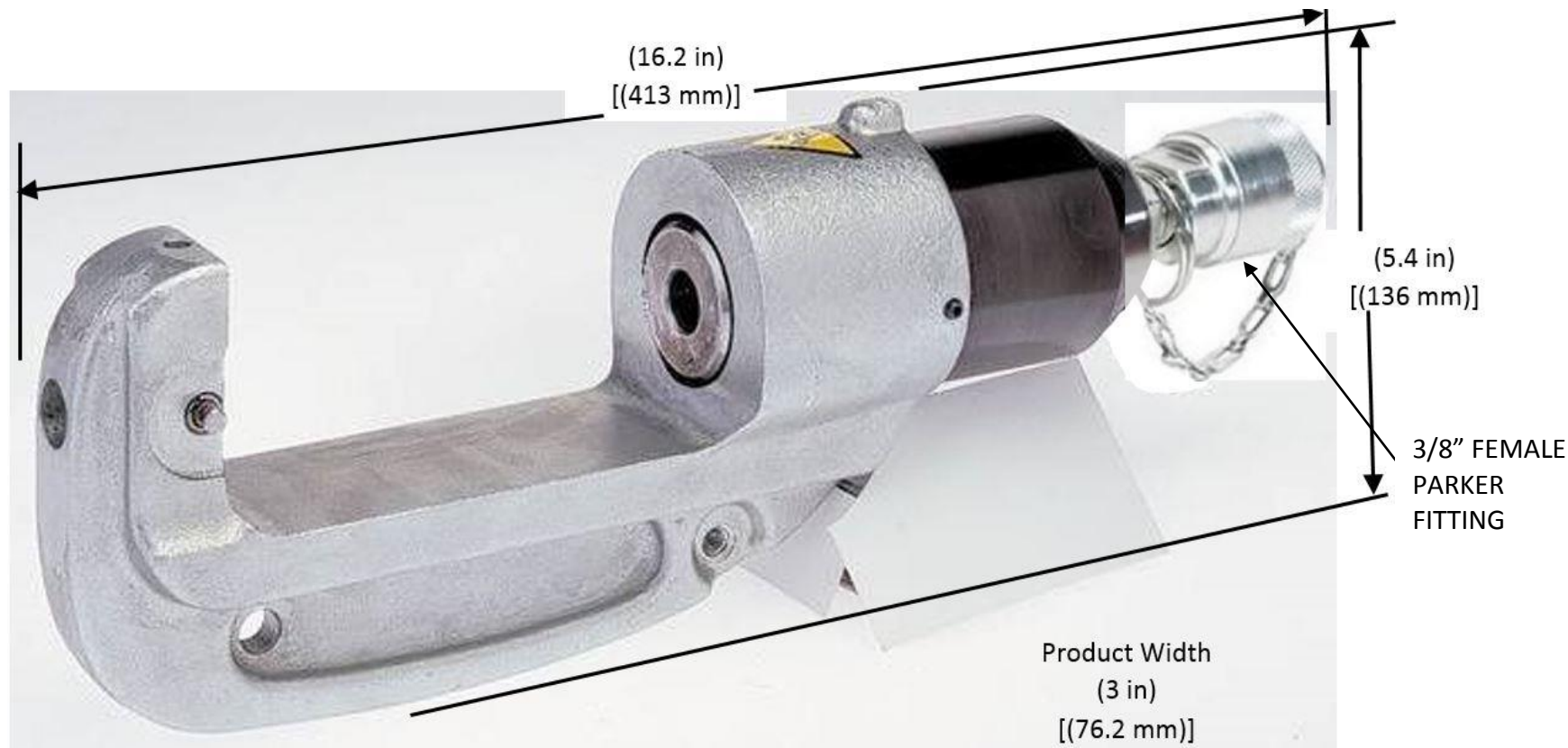

CT-940CH
CRIMP HEAD TOOL



NOTES, UNLESS OTHERWISE SPECIFIED:

The CT-940 Hydraulic Crimping Head Tool is designed to crimp:

- Crimps Panduit Copper and Aluminum compression connectors using Panduit Crimping Dies. Go to www.panduit.com for information.

The CT-940 Tool includes:

| Qty. | Description / Item |
|------|-----------------------------|
| 1 | Hydraulic Crimp Head Tool |
| 1 | CD-940-DAPT Die Adapter Set |
| 1 | Carrying Bag |

Technical Information:

| | |
|----------------|--|
| Tool Weight | 13.7 lbs. (6.2 kg) |
| Dimensions | 16.2" L x 5.4" H x 3" W [413 L x 136 H x 76 W] mm |
| Crimping Force | 15.2 tons (135 kN) |

Tools are to be used with Panduit hydraulic pump, hoses, accessories, and crimp dies, and are sold separately. Go to www.panduit.com for more information.

Copy of the operation manual and accessory information can be found at: www.panduit.com.

Dimensions in [brackets] are in millimeters. All dimensions are for reference only.

| REV | DATE | BY | CHK | APR | DESCRIPTION | ECN | CT-940CH | | | | CUSTOMER DRAWING | |
|-----|----------|-----|------|------|---|--------|---|---------|-----|-------|------------------|--|
| | | | | | | | ITEM REVISION NAME: | | | | | |
| | | | | | | | 00084SLQ_DC/00 | | | | | |
| | | | | | | | UNLESS OTHERWISE SPECIFIED, DIMENSIONAL TOLERANCES ARE: | | | | MATERIAL: | |
| | | | | | | | (.x) ± --- (.xxx) ± --- (.xx) ± --- ANGLES ± --- | | | | DRAWING NUMBER: | |
| | | | | | | | THIRD ANGLE PROJECTION | | | | 00084SLQ_DC | |
| | | | | | | | DRAWN BY: | DATE: | CHK | SCALE | SHT 1 OF 1 | |
| | | | | | | | BKA | 7-21-16 | ACC | NONE | SIZE B | |
| 01 | 12-20-16 | ACC | BJPU | JADE | PARKER FITTING WAS MALE. UPDATED OVERALL LENGTH | 011185 | | | | | | |
| 00 | 7-29-16 | BKA | ACC | JADE | DRAWING RELEASED | 010062 | | | | | | |

Mouser Electronics

Authorized Distributor

Click to View Pricing, Inventory, Delivery & Lifecycle Information:

[Panduit:](#)

[CT-940CH](#)