



LC87F0N04A

CMOS IC 4.5K-byte FROM and 128-byte RAM integrated 8-bit 1-chip Microcontroller

ON Semiconductor®

<http://onsemi.com>

Overview

The LC87F0N04A is an 8-bit microcomputer that, integrates on a single chip a number of hardware features such as 4.5K-byte flash ROM, 128-byte RAM, 16-bit timers/counters, a 16-bit timer, an asynchronous/synchronous SIO interface, motor control 10-bit PWM, two Analog Comparators, a 6-channel AD converter, a system clock frequency divider, an internal reset and an interrupt feature.

Features

■Flash ROM

- 4608 × 8 bits (4096 + 512-byte)
- Capable of On-board programming with wide range (2.8 to 5.5V) of voltage source.
- Block-erasable in 128 byte units
- Writable in 2-byte units

■RAM

- 128 × 9 bits

■Package Form

- SSOP16 (225mil) : Lead-/Halogen-free type

Package Dimensions

unit : mm (typ)

3178B

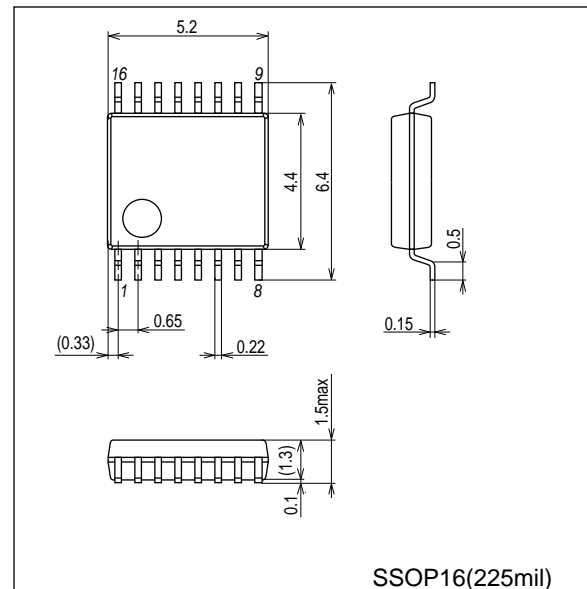

* This product is licensed from Silicon Storage Technology, Inc. (USA).

■ Minimum Bus Cycle

- 100.0ns (10MHz at V_{DD}=2.8V to 5.5V)

Note: The bus cycle time here refers to the ROM read speed.

■ Ports

- Normal withstand voltage I/O ports
Ports I/O direction can be designated in 1 bit units 12(P00 to P03, P1n)
- Reset pin 1 (RES)
- On-chip Debugger pin 1 (OWP0)
- Power pins 2 (VSS, VDD)

■ Timers

- Timer 0: 16-bit timer/counter with a capture register.
 - Mode 0: 8-bit timer with an 8-bit programmable prescaler (with an 8-bit capture register) × 2 channels
 - Mode 1: 8-bit timer with an 8-bit programmable prescaler (with an 8-bit capture register) + 8-bit counter (with an 8-bit capture register)
 - Mode 2: 16-bit timer with an 8-bit programmable prescaler (with a 16-bit capture register)
 - Mode 3: 16-bit counter (with a 16-bit capture register)
- Timer 1: 16-bit timer/counter that supports PWM/toggle outputs
 - Mode 0: 8-bit timer with an 8-bit prescaler (with toggle outputs) × 2 channels
 - Mode 1: 8-bit PWM with an 8-bit prescaler × 2 channels
 - Mode 2: 16-bit timer/counter with an 8-bit prescaler (with toggle outputs)
(toggle outputs also possible from the lower-order 8 bits)
 - Mode 3: 16-bit timer with an 8-bit prescaler (with toggle outputs)
(The lower-order 8 bits can be used as PWM.)
- Base timer
 - 1) The clock is selectable from system clock, and timer 0 prescaler output.
 - 2) Interrupts are programmable in 5 different time schemes

■ SIO

- SIO1: 8-bit asynchronous/synchronous serial interface
 - Mode 0: Synchronous 8-bit serial I/O (2- or 3-wire configuration, 2 to 512 tCYC transfer clocks)
 - Mode 1: Asynchronous serial I/O (half-duplex, 8 data bits, 1 stop bit, 8 to 2048 tCYC baudrates)
 - Mode 2: Bus mode 1 (start bit, 8 data bits, 2 to 512 tCYC transfer clocks)
 - Mode 3: Bus mode 2 (start detect, 8 data bits, stop detect)

■ AD Converter: 10 bits/8 bits × 6 channels

- 10/8 bits AD converter resolution selectable
- Auto start function (It links an interrupt factor of Motor control PWM)

■ Remote Control Receiver Circuit (sharing pins with P11, INT3)

- Noise rejection function (noise filter time constant selectable from 1 tCYC, 32 tCYC, and 128 tCYC)

■ Clock Output Function

- Can generate clock outputs with a frequency of 1/1, 1/2, 1/4, 1/8, 1/16, 1/32, 1/64 of the source clock selected as the system clock.

■ Analog Comparator × 2 channels

- Analog comparator Interrupt.
- Analog comparator reference selectable (External input / Programmable on-chip voltage reference).
The voltage reference has 2 ranges with 16-level voltage levels in each range.
 - Rang1: $CMP1vref1 = (CMP1vref-Register<3:0> + 1) / 16 \times V_{DD} \times 0.64$
 $CMP2vref2 = (CMP2vref-Register<3:0> + 1) / 16 \times V_{DD} \times 0.64$
 - Rang2: $CMP1vref1 = (CMP1vref-Register<3:0> + 1) / 64 \times V_{DD} \times 0.64$
 $CMP2vref2 = (CMP2vref-Register<3:0> + 1) / 64 \times V_{DD} \times 0.64$

■ MCPWM2: Motor control 10bits PWM with Full-Bridge

- Dead time is programmable.
- Forced stop is possible by the output of the analog comparator and the INT terminals.
- Edge-aligned / center-aligned selectable.

LC87F0N04A

■ Watchdog Timer

- Can generate the internal reset signal on a timer overflow monitored by the WDT-dedicated low-speed RC oscillation clock (30kHz).
- Allows selection of continue, stop, or hold mode operation of the counter on entry into the HALT/HOLD mode.

■ Interrupts

- 14 sources, 9 vector addresses
 - 1) Provides three levels (low (L), high (H), and highest (X)) of multiplex interrupt control. Any interrupt requests of the level equal to or lower than the current interrupt are not accepted.
 - 2) When interrupt requests to two or more vector addresses occur at the same time, the interrupt of the highest level takes precedence over the other interrupts. For interrupts of the same level, the interrupt into the smallest vector address takes precedence.

No.	Vector Address	Level	Interrupt Source
1	00003H	X or L	INT0
2	0000BH	X or L	INT1
3	00013H	H or L	INT2/T0L
4	0001BH	H or L	INT3/base timer
5	00023H	H or L	T0H
6	0002BH	H or L	T1L/T1H
7	00033H	H or L	-
8	0003BH	H or L	SIO1/PWM
9	00043H	H or L	ADC
10	0004BH	H or L	CMP1/CMP2

- Priority levels $X > H > L$
- Of interrupts of the same level, the one with the smallest vector address takes precedence.

■ Subroutine Stack Levels: 64levels (The stack is allocated in RAM.)

■ High-speed Multiplication/Division Instructions

- 16 bits \times 8 bits (5 tCYC execution time)
- 24 bits \times 16 bits (12 tCYC execution time)
- 16 bits \div 8 bits (8 tCYC execution time)
- 24 bits \div 16 bits (12 tCYC execution time)

■ Oscillation Circuits

- Internal oscillation circuits
 - Medium-speed RC oscillation circuit : For system clock (1MHz)
 - High-speed RC oscillation circuit : For system clock (10MHz)
 - Low-speed RC oscillation circuit : For watch dog timer (30kHz)

■ System Clock Divider Function

- Can run on low current.
- The minimum instruction cycle selectable from 300ns, 600ns, 1.2 μ s, 2.4 μ s, 4.8 μ s, 9.6 μ s, 19.2 μ s, 38.4 μ s, and 76.8 μ s (at a main clock rate of 10MHz).

■ Internal Reset Function

- Power-on reset (POR) function
 - 1) POR reset is generated only at power-on time.
 - 2) The POR release level can be selected from 8 levels (1.67V, 1.97V, 2.07V, 2.37V, 2.57V, 2.87V, 3.86V, and 4.35V) through option configuration.
- Low-voltage detection reset (LVD) function
 - 1) LVD and POR functions are combined to generate resets when power is turned on and when power voltage falls below a certain level.
 - 2) The use / disuse of the LVD function and the low voltage threshold level (7 levels: 1.91V, 2.01V, 2.31V, 2.51V, 2.81V, 3.79V, 4.28V).

LC87F0N04A

■ Standby Function

- HALT mode: Halts instruction execution while allowing the peripheral circuits to continue operation.
 - 1) Oscillation is not halted automatically.
 - 2) There are three ways of resetting the HALT mode.
 - (1) Setting the reset pin to the low level
 - (2) System resetting by watchdog timer or low-voltage detection
 - (3) Occurrence of an interrupt
- HOLD mode: Suspends instruction execution and the operation of the peripheral circuits.
 - 1) The RC oscillators automatically stop operation.
 - 2) There are four ways of resetting the HOLD mode.
 - (1) Setting the reset pin to the lower level.
 - (2) System resetting by watchdog timer or low-voltage detection
 - (3) Having an interrupt source established at either INT0, INT1, INT2
 - * INT0 and INT1 HOLD mode reset is available only when level detection is set.

■ On-chip Debugger

- Supports software debugging with the IC mounted on the target board.

■ Data Security Function (flash versions only)

- Protects the program data stored in flash memory from unauthorized read or copy.
 Note: This data security function does not necessarily provide absolute data security.

■ Development Tools

- On-chip-debugger : TCB87 TypeC + LC87F0N04A

■ Programming Boards

Package	Programming boards
SSOP16(225mil)	W87F0NS

■ Flash ROM Programmer

Maker		Model	Supported version	Device
Flash Support Group, Inc. (FSG)	Single Programmer	AF9709/AF9709B/AF9709C (Including Ando Electric Co., Ltd. models)	Rev 03.28 or later	87F008SU (3B247)
	Gang Programmer	AF9723/AF9723B(Main body) (Including Ando Electric Co., Ltd. models)	-	-
		AF9833(Unit) (Including Ando Electric Co., Ltd. models)	-	-
Sanyo	Single/Gang Programmer	SKK / SKK Type B (SanyoFWS)	Application Version 1.07 or later	LC87F0N04
	Gang Programmer	SKK-4G (SanyoFWS)	Chip Data Version 2.40 or later	
	In-circuit/Gang Programmer	SKK-DBG Type C (SanyoFWS)	Application Version 1.07 or later Chip Data Version 2.40 or later	

For information about AF-Series:

Flash Support Group, Inc.
 TEL: +81-53-459-1050
 E-mail: sales@j-fsg.co.jp

LC87F0N04A

Pin Assignment

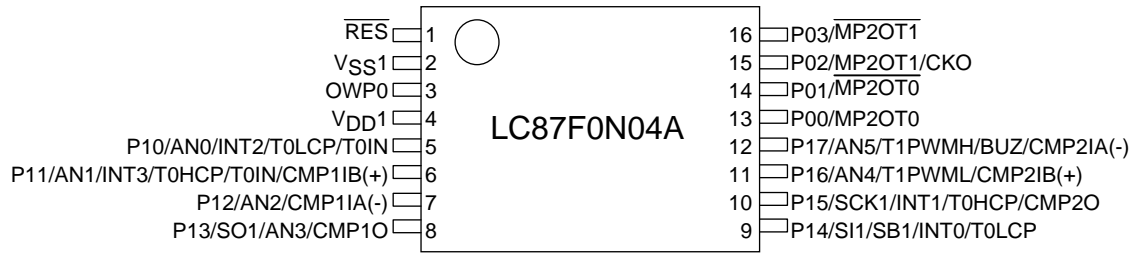

Top view

SANYO: SSOP16(225mil) "Lead-/Halogen-free Type"

SSOP16	NAME
1	RES
2	VSS1
3	OWP0
4	VDD1
5	P10/AN0/INT2/T0LCP/T0IN
6	P11/AN1/INT3/T0HCP/T0IN/CMP1IB(+)
7	P12/AN2/CMP1IA(-)
8	P13/SO1/AN3/CMP1O

SSOP16	NAME
9	P14/SI1/SB1/INT0/T0LCP
10	P15/SCK1/INT1/T0HCP/CMP2O
11	P16/AN4/T1PWML/CMP2IB(+)
12	P17/AN5/T1PWMH/CMP2IA(-)/BUZ
13	P00/MP2OT0
14	P01/MP2OT0
15	P02/MP2OT1/CKO
16	P03/MP2OT1

LC87F0N04A

System Block Diagram

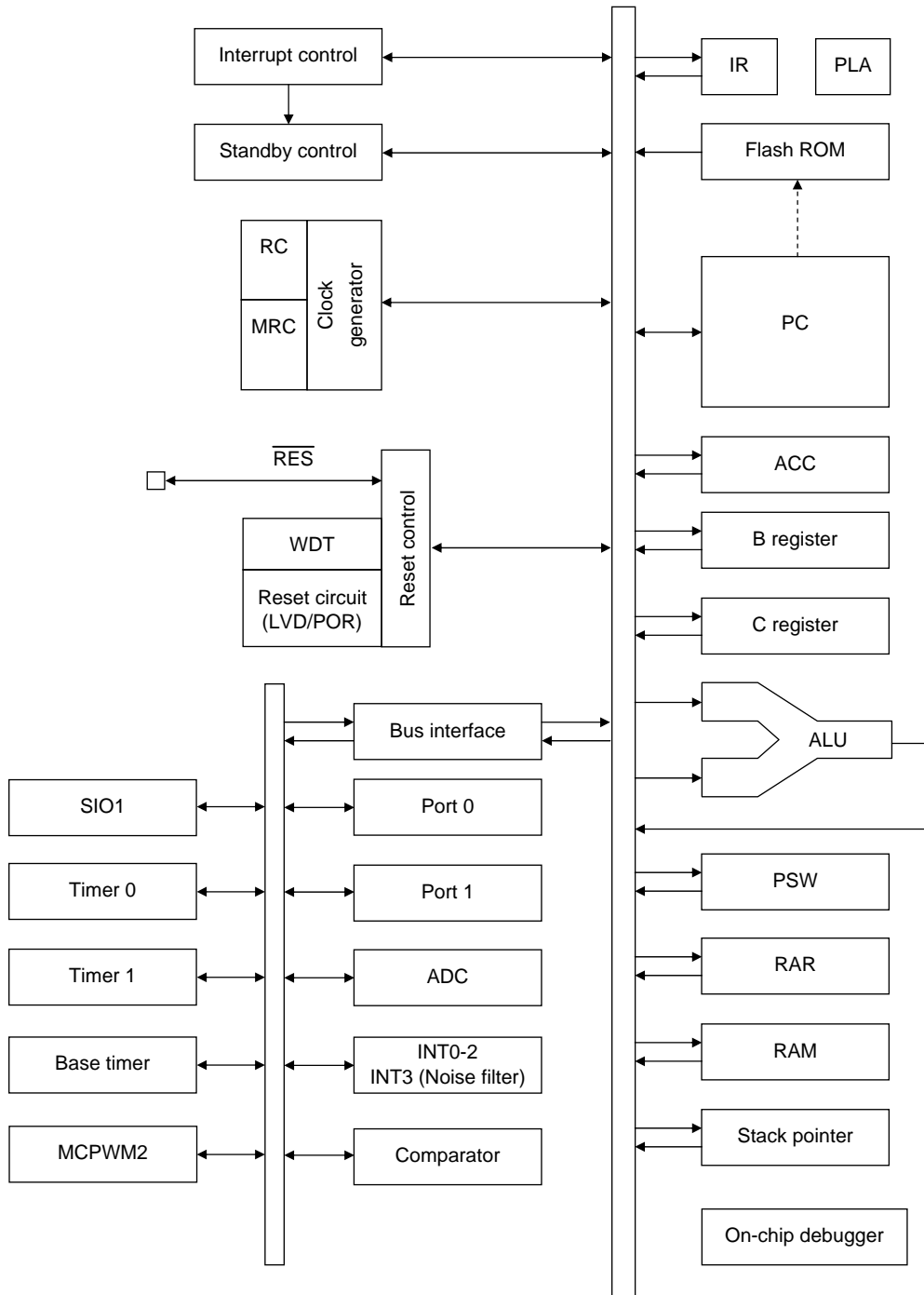

LC87F0N04A

Pin Description

Pin Name	I/O	Description	Option																														
V _{SS} 1	-	- power supply pin	No																														
V _{DD} 1	-	+ power supply pin	No																														
Port 0 P00 to P03	I/O	<ul style="list-style-type: none"> • 4-bit I/O port • I/O specifiable in 1 bit units • Pull-up resistors can be turned on and off in 1 bit units. • Pin functions <ul style="list-style-type: none"> P00: $\overline{\text{MP2OT0}}$(PWM output) P01: $\overline{\text{MP2OT0}}$ (PWM output) P02: $\overline{\text{MP2OT1}}$(PWM output) / System clock output P03: $\overline{\text{MP2OT1}}$ (PWM output) 	Yes																														
Port 1 P10 to P17	I/O	<ul style="list-style-type: none"> • 8-bit I/O port • I/O specifiable in 1 bit units • Pull-up resistors can be turned on and off in 1 bit units. • Pin functions <ul style="list-style-type: none"> P10: AN0(AD converter input) / INT2 input / HOLD reset input / timer 0 event input / timer 0L capture input P11: AN1(AD converter input) / INT3 input (with noise filter) / timer 0 event input / timer 0H capture input / CMP1(+) input P12: AN2(AD converter input) / CMP1(-) input P13: SIO1 data output / AN3(AD converter input) / CMP1 output P14: SIO1 data input / bus I/O / INT0 input / HOLD reset input / timer 0L capture input P15: SIO1 clock I/O / INT1 input / HOLD reset input / timer 0H capture input / CMP2 output P16: Timer 1PWML output / CMP2(+) input / AN4(AD converter input) P17: Timer 1PWML output / beeper output / CMP2(-) input / AN5(AD converter input) <p>Interrupt acknowledge type</p> <table border="1" style="width: 100%; border-collapse: collapse; text-align: center;"> <thead> <tr> <th></th> <th>Rising</th> <th>Falling</th> <th>Rising & Falling</th> <th>H level</th> <th>L level</th> </tr> </thead> <tbody> <tr> <td>INT0</td> <td>enable</td> <td>enable</td> <td>disable</td> <td>enable</td> <td>enable</td> </tr> <tr> <td>INT1</td> <td>enable</td> <td>enable</td> <td>disable</td> <td>enable</td> <td>enable</td> </tr> <tr> <td>INT2</td> <td>enable</td> <td>enable</td> <td>enable</td> <td>disable</td> <td>disable</td> </tr> <tr> <td>INT3</td> <td>enable</td> <td>enable</td> <td>enable</td> <td>disable</td> <td>disable</td> </tr> </tbody> </table>		Rising	Falling	Rising & Falling	H level	L level	INT0	enable	enable	disable	enable	enable	INT1	enable	enable	disable	enable	enable	INT2	enable	enable	enable	disable	disable	INT3	enable	enable	enable	disable	disable	Yes
	Rising	Falling	Rising & Falling	H level	L level																												
INT0	enable	enable	disable	enable	enable																												
INT1	enable	enable	disable	enable	enable																												
INT2	enable	enable	enable	disable	disable																												
INT3	enable	enable	enable	disable	disable																												
OWP0	I/O	On-chip debugger (exclusive pin)	No																														
RES	I/O	External reset Input / internal reset output	No																														

LC87F0N04A

Port Output Types

The table below lists the types of port outputs and the presence/absence of a pull-up resistor. Data can be read into any input port even if it is in the output mode.

Port Name	Option selected in units of	Option type	Output type	Pull-up resistor
P00 to P03 P10 to P17	1 bit	1	CMOS	Programmable
		2	Nch-open drain	Programmable

User Option Table

Option Name	Option to be Applied on	Flash-ROM Version	Option Selected in Units of	Option Selection
Port output type	P00 to P03	○	1 bit	CMOS
				Nch-open drain
	P10 to P17	○	1 bit	CMOS
				Nch-open drain
Low-voltage detection reset function	Detect function	○	-	Enable:Use Disable:Not Used
	Detect level	○	-	7-level
Power-on reset function	Power-On reset level	○	-	8-level

Recommended Unused Pin Connections

Port Name	Recommended Unused Pin Connections	
	Board	Software
P00 to P03	Open	Output low
P10 to P17	Open	Output low

On-chip Debugger Pin Connection Requirements

Install and connect a limiting resistor (100Ω) to the on-chip debugger dedicated pin (OWP0) on the user board and pull the pin down (100kΩ). It is recommended to install a dedicated connector to accept the cable to the debugging tool (TCB87 Type C). The connector must accommodate three lines, i.e., VSS1, OWP0, and VDD1.

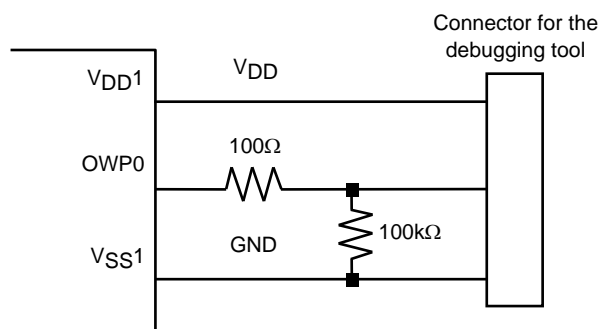

LC87F0N04A

Absolute Maximum Ratings at Ta = 25°C, VSS1 = 0V

Parameter	Symbol	Pin/Remarks	Conditions	Specification				unit	
				V _{DD} [V]	min	typ	max		
Maximum supply voltage	V _{DD max}	V _{DD1}			-0.3		+6.5	V	
Input voltage	V _I	$\overline{\text{RES}}$			-0.3		V _{DD} +0.3		
Input/output voltage	V _{IO}	Ports 0, 1			-0.3		V _{DD} +0.3		
High level output current	Peak output current	IOPH(1)	Ports 0, 1	CMOS output select Per 1 applicable pin		-10		mA	
	Mean output current (Note 1-1)	IOMH(1)	Ports 0, 1	CMOS output select Per 1 applicable pin		-7.5			
	Total output current	ΣIOAH(1)	Ports 0	Total of all applicable pins		-25			
		ΣIOAH(2)	Ports 1	Total of all applicable pins		-25			
Low level output current	Peak output current	IOPL(1)	Ports0, 1	Per 1 applicable pin			20		
	Mean output current (Note 1-1)	IOML(1)	Ports 0, 1	Per 1 applicable pin			15		
	Total output current	ΣIOAL(1)	Ports 0	Total of all applicable pins				45	
		ΣIOAL(2)	Ports 1	Total of all applicable pins				45	
Power dissipation	Pdmax	SSOP16	Ta=-40 to +85°C Package with thermal resistance board (Note 1-2)				238	mW	
Operating ambient temperature	Topr				-40		+85	°C	
Storage ambient temperature	Tstg				-55		+125		

Note 1-1: The mean output current is a mean value measured over 100ms.

Note 1-2: SEMI standards thermal resistance board (size: 76.1×114.3×1.6tmm, glass epoxy) is used.

Stresses exceeding Maximum Ratings may damage the device. Maximum Ratings are stress ratings only. Functional operation above the Recommended Operating Conditions is not implied. Extended exposure to stresses above the Recommended Operating Conditions may affect device reliability.

LC87F0N04A

Allowable Operating Conditions at $T_a = -40^{\circ}\text{C}$ to $+85^{\circ}\text{C}$, $V_{SS1} = 0\text{V}$

Parameter	Symbol	Pin/Remarks	Conditions	Specification				unit
				$V_{DD}[\text{V}]$	min	typ	max	
Operating supply voltage	$V_{DD}(1)$	V_{DD1}	$0.291\mu\text{s} \leq t\text{CYC} \leq 200\mu\text{s}$		2.8		5.5	V
Memory sustaining supply voltage	V_{HD}	V_{DD1}	RAM and register contents sustained in HOLD mode.		2.0			
High level input voltage	$V_{IH}(1)$	Ports 1		2.8 to 5.5	$0.3V_{DD} + 0.7$		V_{DD}	
	$V_{IH}(2)$	Ports 0		2.8 to 5.5	$0.3V_{DD} + 0.7$		V_{DD}	
	$V_{IH}(3)$	$\overline{\text{RES}}$		2.8 to 5.5	$0.75V_{DD}$		V_{DD}	
Low level input voltage	$V_{IL}(1)$	Ports 1		4.0 to 5.5	V_{SS}		$0.1V_{DD} + 0.4$	
				2.8 to 4.0	V_{SS}		$0.2V_{DD}$	
	$V_{IL}(2)$	Ports 0		4.0 to 5.5	V_{SS}		$0.15V_{DD} + 0.4$	
				2.8 to 4.0	V_{SS}		$0.2V_{DD}$	
$V_{IL}(3)$	$\overline{\text{RES}}$		2.8 to 5.5	V_{SS}		$0.25V_{DD}$		
Instruction cycle time (Note 2-1)	tCYC			2.8 to 5.5	0.291		200	μs
Oscillation frequency range	FmMRC(1)		Internal High-speed RC oscillation. (Note 2-2)	2.8 to 5.5	9.7	10.0	10.3	MHz
	FmMRC(2)		Internal High-speed RC oscillation. $T_a=0^{\circ}\text{C}$ to 85°C (Note 2-2)	2.8 to 5.5	9.75	10.0	10.25	MHz
	FmRC		Internal Medium-speed RC oscillation	2.8 to 5.5	0.5	1.0	2.0	MHz
	FmSRC		Internal Slow-speed RC oscillation for watchdog timer.	2.8 to 5.5	15	30	60	kHz

Note 2-1: Relationship between tCYC and oscillation frequency is $3/\text{FmMRC}$ at a division ratio of 1/1 and $6/\text{FmMRC}$ at a division ratio of 1/2.

Note 2-2: When switching the system clock, allow an oscillation stabilization time of $100\mu\text{s}$ or longer after the High-speed RC oscillator circuit transmits from the "oscillation stopped" to "oscillation enabled" state.

LC87F0N04A

Electrical Characteristics at Ta = -40°C to +85°C, VSS1 = 0V

Parameter	Symbol	Pin/Remarks	Conditions	Specification				
				VDD[V]	min	typ	max	unit
High level input current	I _{IH} (1)	Ports 0, 1 $\overline{\text{RES}}$	Output disabled Pull-up resistor off V _{IN} =V _{DD} (Including output Tr's off leakage current)	2.8 to 5.5			1	μA
Low level input current	I _{IL} (1)	Ports 0, 1 $\overline{\text{RES}}$	Output disabled Pull-up resistor off V _{IN} =V _{SS} (Including output Tr's off leakage current)	2.8 to 5.5		-1		
High level output voltage	V _{OH} (1)	Ports 0, 1	I _{OH} =-1mA	4.5 to 5.5	V _{DD} -1			V
	V _{OH} (2)		I _{OH} =-0.35mA	2.8 to 5.5	V _{DD} -0.4			
	V _{OH} (3)	Port0 (Note 3-1)	I _{OH} =-6mA	4.5 to 5.5	V _{DD} -1			
	V _{OH} (4)		I _{OH} =-1.4mA	2.8 to 5.5	V _{DD} -0.4			
Low level output voltage	V _{OL} (1)	Ports 0, 1	I _{OL} =10mA	4.5 to 5.5			1.5	
	V _{OL} (2)		I _{OL} =1.4mA	2.8 to 5.5			0.4	
Pull-up resistance	R _{pu} (1)	Ports 0, 1	V _{OH} =0.9V _{DD}	4.5 to 5.5		15	35	kΩ
	R _{pu} (2)			2.8 to 4.5		18	50	
Hysteresis voltage	VHYS	P10(INT2), P11(INT3), P14,P15, $\overline{\text{RES}}$		2.8 to 5.5			0.1 V _{DD}	V
Pin capacitance	CP	All pins	For pins other than that under test: V _{IN} =V _{SS} f=1MHz Ta=25°C	2.8 to 5.5			10	pF

Note 3-1: When Ports0 selected MCPWM2.

LC87F0N04A

SIO1 Serial I/O Characteristics at Ta = -40°C to +85°C, VSS1 = 0V (Note 4)

Parameter		Symbol	Pin/ Remarks	Conditions	V _{DD} [V]	Specification				
						min	typ	max	unit	
Serial clock	Input clock	Frequency	tSCK(3)	SCK1(P15)	• See Fig. 4.	2.8 to 5.5	2			tCYC
		Low level pulse width	tSCKL(3)				1			
		High level pulse width	tSCKH(3)				1			
	Output clock	Frequency	tSCK(4)	SCK1(P15)	• CMOS output selected • See Fig. 4.	2.8 to 5.5	2			tSCK
		Low level pulse width	tSCKL(4)				1/2			
		High level pulse width	tSCKH(4)				1/2			
Serial input	Data setup time	tsDI(2)	SB1(P14), S11(P14)	• Must be specified with respect to rising edge of SIOCLK. • See Fig. 4.	2.8 to 5.5	0.05				
	Data hold time	thDI(2)				0.05				
Serial output	Output delay time	tdD0(4)	SO1(P13), SB1(P14)	• Must be specified with respect to falling edge of SIOCLK. • Must be specified as the time to the beginning of output state change in open drain output mode. • See Fig. 4.	2.8 to 5.5			(1/2)tCYC +0.08	μs	

Note 4: These specifications are theoretical values. Add margin depending on its use.

Pulse Input Conditions at Ta = -40°C to +85°C, VSS1 = 0V

Parameter	Symbol	Pin/Remarks	Conditions	V _{DD} [V]	Specification			
					min	typ	max	unit
High/low level pulse width	tPIH(1) tPIL(1)	INT0(P14), INT1(P15), INT2(P10)	• Interrupt source flag can be set. • Event inputs for timer 0 or 1 are enabled.	2.8 to 5.5	1			tCYC
	tPIH(2) tPIL(2)	INT3(P11) when noise filter time constant is 1/1	• Interrupt source flag can be set. • Event inputs for timer 0 are enabled.	2.8 to 5.5	2			
	tPIH(3) tPIL(3)	INT3(P11) when noise filter time constant is 1/32	• Interrupt source flag can be set. • Event inputs for timer 0 are enabled.	2.8 to 5.5	64			
	tPIH(4) tPIL(4)	INT3(P11) when noise filter time constant is 1/128	• Interrupt source flag can be set. • Event inputs for timer 0 are enabled.	2.8 to 5.5	256			
	tPIL(5)	RES	• Resetting is enabled.	2.8 to 5.5	200			μs

LC87F0N04A

AD Converter Characteristics at $V_{SS1} = 0V$

<10bits AD Converter Mode/ $T_a = -40^{\circ}C$ to $+85^{\circ}C$ >

Parameter	Symbol	Pin/Remarks	Conditions	Specification				
				$V_{DD}[V]$	min	typ	max	unit
Resolution	N	AN0(P10) to		2.8 to 5.5		10		bit
Absolute accuracy	ET	AN3(P13) AN4(P16)	(Note 6-1)	2.8 to 5.5			± 4	LSB
Conversion time	TCAD	AN5(P17)	• See Conversion time calculation formulas. (Note 6-2)	4.0 to 5.5	7.8		65.6	μs
				2.8 to 5.5	15		65.6	
Analog input voltage range	VAIN			2.8 to 5.5	V_{SS}		V_{DD}	V
Analog port input current	I _{AINH}		VAIN= V_{DD}	2.8 to 5.5			1	μA
	I _{AINL}		VAIN= V_{SS}	2.8 to 5.5	-1			

<8bits AD Converter Mode/ $T_a = -40^{\circ}C$ to $+85^{\circ}C$ >

Parameter	Symbol	Pin/Remarks	Conditions	Specification				
				$V_{DD}[V]$	min	typ	max	unit
Resolution	N	AN0(P10) to		2.8 to 5.5		8		bit
Absolute accuracy	ET	AN3(P13) AN4(P16)	(Note 6-1)	2.8 to 5.5			± 1.5	LSB
Conversion time	TCAD	AN5(P17)	• See Conversion time calculation formulas. (Note 6-2)	4.0 to 5.5	2.85		25.0	μs
				2.8 to 5.5	5.5		25.0	
Analog input voltage range	VAIN			2.8 to 5.5	V_{SS}		V_{DD}	V
Analog port input current	I _{AINH}		VAIN= V_{DD}	2.8 to 5.5			1	μA
	I _{AINL}		VAIN= V_{SS}	2.8 to 5.5	-1			

Conversion time calculation formulas:

10bits AD Converter Mode: $TCAD(\text{Conversion time}) = ((40/(\text{AD division ratio}))+2) \times (1/3) \times t_{CYC}$

8bits AD Converter Mode: $TCAD(\text{Conversion time}) = ((28/(\text{AD division ratio}))+2) \times (1/3) \times t_{CYC}$

External oscillation (F _m MRC)	Operating supply voltage range (V_{DD})	System division ratio (SYSDIV)	Cycle time (t _{CYC})	AD division ratio (ADDIV)		AD conversion time (TCAD)	
				10bit AD	8bit AD	10bit AD	8bit AD
10MHz	4.0V to 5.5V	1/1	300ns	1/2	1/1	8.5 μs	2.9 μs
	2.8V to 5.5V	1/1	300ns	1/4	1/2	17 μs	5.8 μs

Note 6-1: The quantization error ($\pm 1/2$ LSB) must be excluded from the absolute accuracy. The absolute accuracy must be measured in the microcontroller's state in which no I/O operations occur at the pins adjacent to the analog input channel.

Note 6-2: The conversion time refers to the period from the time an instruction for starting a conversion process till the time the conversion results register(s) are loaded with a complete digital conversion value corresponding to the analog input value.

The conversion time is 2 times the normal-time conversion time when:

- The first AD conversion is performed in the 10-bit AD conversion mode after a system reset.
- The first AD conversion is performed after the AD conversion mode is switched from 8-bit to 10-bit conversion mode.

LC87F0N04A

Power-on Reset (POR) Characteristics at Ta = -40°C to +85°C, VSS1 = 0V

Parameter	Symbol	Pin/Remarks	Conditions	Specification				
				Option selected voltage	min	typ	max	unit
POR release voltage	PORRL		<ul style="list-style-type: none"> Select from option. (Note 7-1) 	1.67V	1.55	1.67	1.79	V
				1.97V	1.85	1.97	2.09	
				2.07V	1.95	2.07	2.19	
				2.37V	2.25	2.37	2.49	
				2.57V	2.45	2.57	2.69	
				2.87V	2.75	2.87	2.99	
				3.86V	3.73	3.86	3.99	
				4.35V	4.21	4.35	4.49	
Detection voltage unknown state	POUKS		<ul style="list-style-type: none"> See Fig. 6. (Note 7-2) 			0.7	0.95	
Power supply rise time	PORIS		<ul style="list-style-type: none"> Power supply rise time from 0V to 1.6V. 				100	ms

Note7-1: The POR release level can be selected out of 8 levels only when the LVD reset function is disabled.

Note7-2: POR is in an unknown state before transistors start operation.

Low Voltage Detection Reset (LVD) Characteristics at Ta = -40°C to +85°C, VSS1=0V

Parameter	Symbol	Pin/Remarks	Conditions	Specification				
				Option selected voltage	min	typ	max	unit
LVD reset voltage (Note 8-2)	LVDET		<ul style="list-style-type: none"> Select from option. (Note 8-1) (Note 8-3) See Fig. 7. 	1.91V	1.81	1.91	2.01	V
				2.01V	1.91	2.01	2.11	
				2.31V	2.21	2.31	2.41	
				2.51V	2.41	2.51	2.61	
				2.81V	2.71	2.81	2.91	
				3.79V	3.69	3.79	3.89	
				4.28V	4.18	4.28	4.38	
LVD hysteresys width	LVHYS			1.91V		55		mV
				2.01V		55		
				2.31V		55		
				2.51V		55		
				2.81V		60		
				3.79V		65		
				4.28V		65		
Detection voltage unknown state	LVUKS		<ul style="list-style-type: none"> See Fig. 7. (Note 8-4) 			0.7	0.95	V
Low voltage detection minimum width (Reply sensitivity)	TLVDW		<ul style="list-style-type: none"> LVDET-0.5V See Fig. 8. 		0.2			ms

Note8-1: The LVD reset level can be selected out of 7 levels only when the LVD reset function is enabled.

Note8-2: LVD reset voltage specification values do not include hysteresis voltage.

Note8-3: LVD reset voltage may exceed its specification values when port output state changes and/or when a large current flows through port.

Note8-4: LVD is in an unknown state before transistors start operation.

LC87F0N04A

Comparator Characteristics at Ta = -40°C to +85°C, VSS1 = 0V

Parameter	Symbol	Pin/ Remarks	Conditions	Specification				
				V _{DD} [V]	min	typ	max	unit
Input common-mode voltage (Note9-1)	VCMIN	P12(CMP1IA), P11(CMP1IB), P17(CMP2IA), P16(CMP2IB)		2.8 to 5.5	V _{SS}		V _{DD} -1.5V	V
Offset voltage	VCPOFF(1)	P12(CMP1IA), P11(CMP1IB), P17(CMP2IA), P16(CMP2IB)	<ul style="list-style-type: none"> • Input common-mode voltage range • CMP1 minus input = CMP1IA • CMP2 minus input = CMP2IA 	2.8 to 5.5			±20	mV
	VCPOFF(2)	P12(CMP1IA), P11(CMP1IB), P17(CMP2IA), P16(CMP2IB)	<ul style="list-style-type: none"> • Input common-mode voltage range • CMP1 minus input = CMP1vref (Note9-2) • CMP2 minus input = CMP2vref (Note9-2) 	2.8 to 5.5			±40	mV
CMP response speed	tCRT	P13(CMP1O), P15(CMP2O)	<ul style="list-style-type: none"> • Input common-mode voltage range • Input amplitude=100mV, Over drive=50mV • CMP1 minus input = CMP1IA • CMP2 minus input = CMP2IA 	2.8 to 5.5		200		ns

Note9-1: When V_{DD}=5V, input voltage is effective from 0 to 3.5V.

Note9-2:

$$\text{Rang1: CMP1vref1} = (\text{CMP1vref-Register}<3:0> + 1) / 16 \times V_{DD} \times 0.64$$

$$\text{CMP2vref2} = (\text{CMP2vref-Register}<3:0> + 1) / 16 \times V_{DD} \times 0.64$$

$$\text{Rang2: CMP1vref1} = (\text{CMP1vref-Register}<3:0> + 1) / 64 \times V_{DD} \times 0.64$$

$$\text{CMP2vref2} = (\text{CMP2vref-Register}<3:0> + 1) / 64 \times V_{DD} \times 0.64$$

*: Range1/Range2 setting by a register is common to comparators 1 and 2.

LC87F0N04A

Consumption Current Characteristics at Ta = -40°C to +85°C, VSS1 = 0V

Parameter	Symbol	Pin/ Remarks	Conditions	Specification				
				V _{DD} [V]	min	typ	max	unit
Normal mode consumption current (Note 10-1) (Note 10-2)	IDDOP(1)	V _{DD} 1	<ul style="list-style-type: none"> Internal Medium speed RC oscillation stopped. System clock set to internal High speed RC oscillation(10MHz). 1/1 frequency division ratio 	2.8 to 5.5		3.4	4.8	mA
	IDDOP(2)		<ul style="list-style-type: none"> Internal High speed RC oscillation stopped. System clock set to internal Medium speed RC oscillation. 1/2 frequency division ratio 	2.8 to 5.5		0.2	0.4	
HALT mode consumption current (Note 10-1) (Note 10-2)	IDDHALT(1)	V _{DD} 1	<ul style="list-style-type: none"> HALT mode Internal Medium speed RC oscillation stopped. System clock set to internal High speed RC oscillation(10MHz). 1/1 frequency division ratio 	2.8 to 5.5		1.6	2.3	mA
	IDDHALT(2)	V _{DD} 1	<ul style="list-style-type: none"> HALT mode Internal High speed RC oscillation stopped. System clock set to internal Medium speed RC oscillation. 1/2 frequency division ratio 	2.8 to 5.5		0.10	0.19	
HOLD mode consumption current (Note 10-1) (Note 10-2) (Note 10-3)	IDDHOLD(1)	V _{DD} 1	HOLD mode	2.8 to 5.5		0.03	32	μA
	IDDHOLD(2)		HOLD mode <ul style="list-style-type: none"> LVD option selected 	2.8 to 5.5		3	35	

Note10-1: Values of the consumption current do not include current that flows into the output transistors and internal pull-up resistors.

Note10-2: The consumption current values do not include operational current of LVD function if not specified.

Note10-3: The amplifier / comparator circuit operates in the HOLD mode.

F-ROM Programming Characteristics at Ta = +10°C to +55°C, VSS1 = 0V

Parameter	Symbol	Pin/Remarks	Conditions	Specification				
				V _{DD} [V]	min	typ	max	unit
Onboard programming current	IDDFW(1)	V _{DD} 1	<ul style="list-style-type: none"> Only current of the Flash block. 	2.8 to 5.5		5	10	mA
Programming time	tFW(1)		<ul style="list-style-type: none"> Erasing time 	2.8 to 5.5		20	30	ms
	tFW(2)		<ul style="list-style-type: none"> Programming time 			40	60	μs

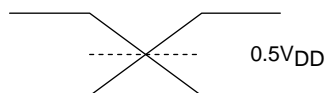

Figure 1 AC Timing Measurement Point

LC87F0N04A

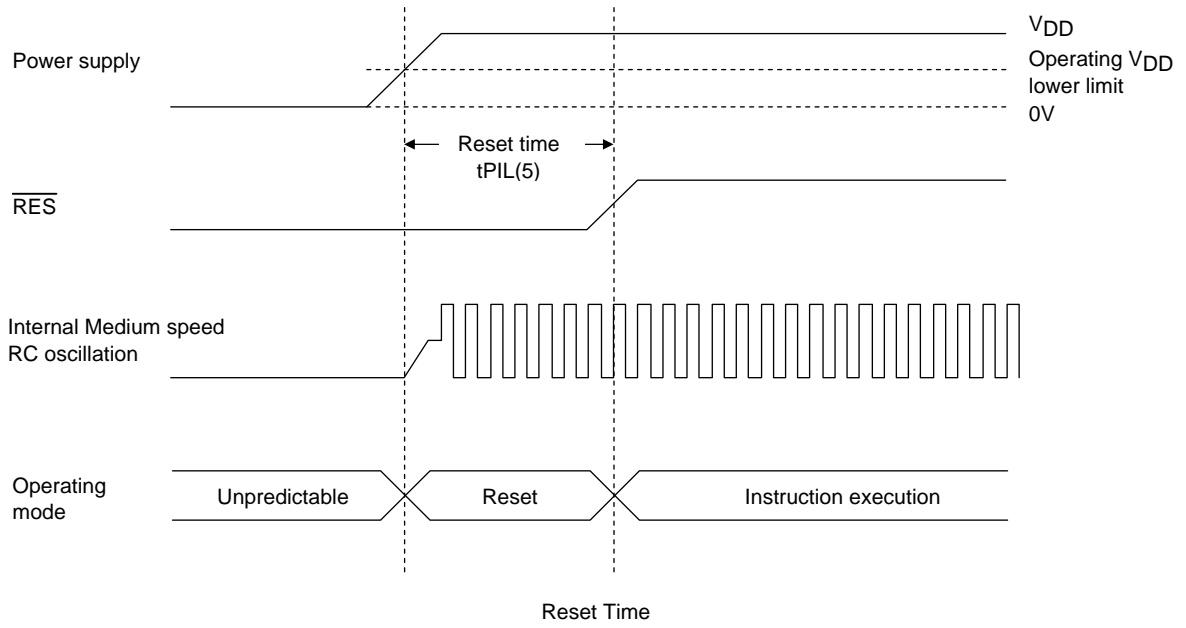
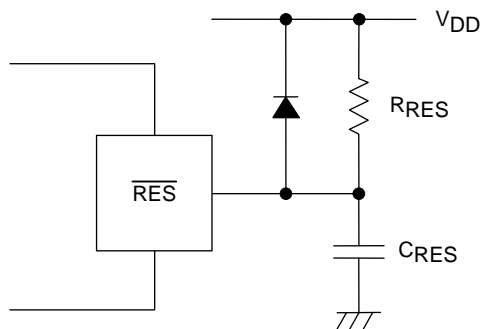

Figure 2 Reset Time



Note:
 External circuits for reset may vary depending on the usage of POR and LVD. Please refer to the user's manual for more information.

Figure 3 Reset Circuit

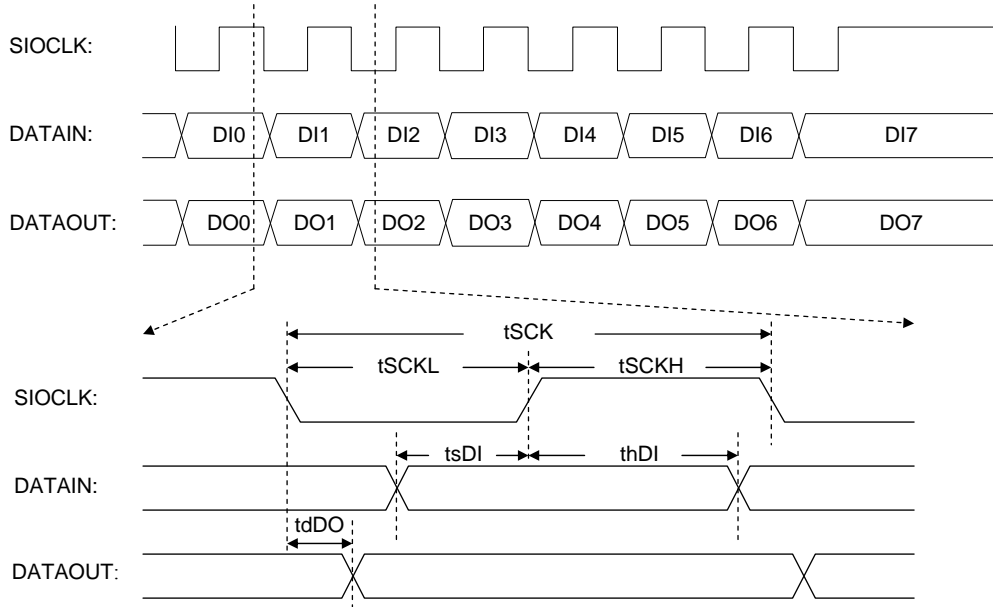

Figure 4 Serial I/O Output Waveforms

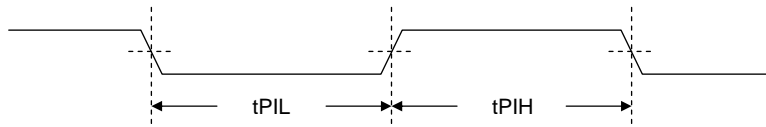

Figure 5 Pulse Input Timing Signal Waveform

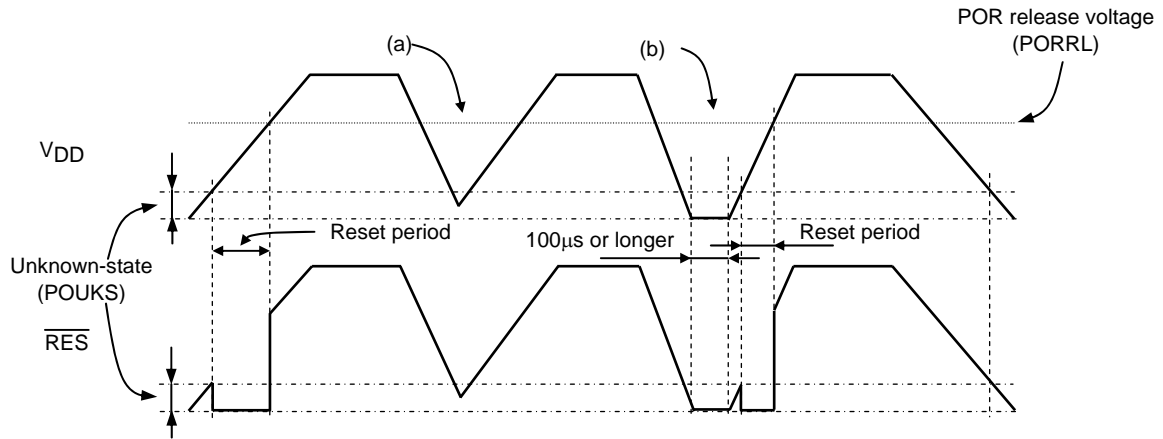

Figure 6 Waveform observed when only POR is used (LVD not used)
(RESET pin: Pull-up resistor RRES only)

- The POR function generates a reset only when power is turned on starting at the V_{SS} level.
- No stable reset will be generated if power is turned on again when the power level does not go down to the V_{SS} level as shown in (a). If such a case is anticipated, use the LVD function together with the POR function or implement an external reset circuit.
- A reset is generated only when the power level goes down to the V_{SS} level as shown in (b) and power is turned on again after this condition continues for 100µs or longer.

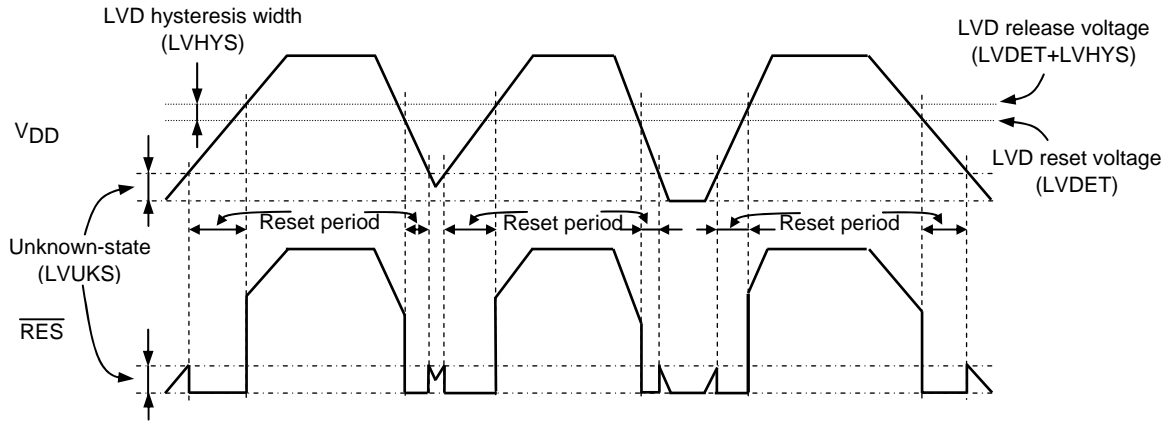

Figure 7 Waveform observed when both POR and LVD functions are used (RESET pin: Pull-up resistor RRES only)

- Resets are generated both when power is turned on and when the power level lowers.
- A hysteresis width (LVHYS) is provided to prevent the repetitions of reset release and entry cycles near the detection level.

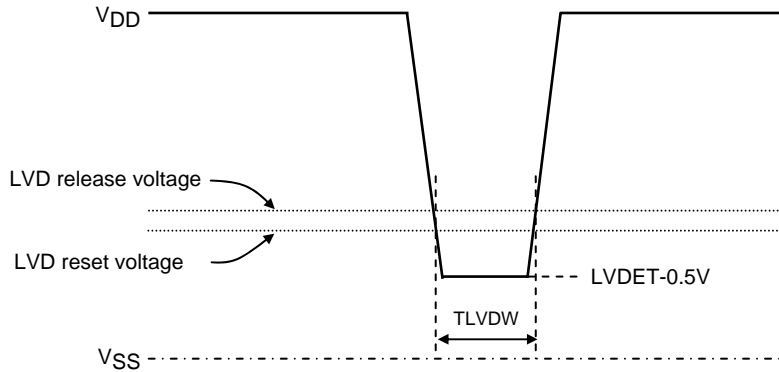

Figure 8 Low voltage detection minimum width (Example of momentary power loss/Voltage variation waveform)

ON Semiconductor and the ON logo are registered trademarks of Semiconductor Components Industries, LLC (SCILLC). SCILLC owns the rights to a number of patents, trademarks, copyrights, trade secrets, and other intellectual property. A listing of SCILLC's product/patent coverage may be accessed at www.onsemi.com/site/pdf/Patent-Marking.pdf. SCILLC reserves the right to make changes without further notice to any products herein. SCILLC makes no warranty, representation or guarantee regarding the suitability of its products for any particular purpose, nor does SCILLC assume any liability arising out of the application or use of any product or circuit, and specifically disclaims any and all liability, including without limitation special, consequential or incidental damages. "Typical" parameters which may be provided in SCILLC data sheets and/or specifications can and do vary in different applications and actual performance may vary over time. All operating parameters, including "Typicals" must be validated for each customer application by customer's technical experts. SCILLC does not convey any license under its patent rights nor the rights of others. SCILLC products are not designed, intended, or authorized for use as components in systems intended for surgical implant into the body, or other applications intended to support or sustain life, or for any other application in which the failure of the SCILLC product could create a situation where personal injury or death may occur. Should Buyer purchase or use SCILLC products for any such unintended or unauthorized application, Buyer shall indemnify and hold SCILLC and its officers, employees, subsidiaries, affiliates, and distributors harmless against all claims, costs, damages, and expenses, and reasonable attorney fees arising out of, directly or indirectly, any claim of personal injury or death associated with such unintended or unauthorized use, even if such claim alleges that SCILLC was negligent regarding the design or manufacture of the part. SCILLC is an Equal Opportunity/Affirmative Action Employer. This literature is subject to all applicable copyright laws and is not for resale in any manner.

Mouser Electronics

Authorized Distributor

Click to View Pricing, Inventory, Delivery & Lifecycle Information:

[onsemi:](#)

[LC87F0N04AUJD-H](#)