



Freescale Semiconductor, Inc.



Freescale Semiconductor, Inc.

# M•CORE Microcontrollers

MMC2114  
MMC2113  
MMC2112

*Advance Information*

MMC2114/D  
Rev. 1, 4/2002

[WWW.MOTOROLA.COM/SEMICONDUCTORS](http://WWW.MOTOROLA.COM/SEMICONDUCTORS)

**For More Information On This Product,  
Go to: [www.freescale.com](http://www.freescale.com)**



**Freescale Semiconductor, Inc.**

**Freescale Semiconductor, Inc.**

**For More Information On This Product,  
Go to: [www.freescale.com](http://www.freescale.com)**

# MMC2114

# MMC2113

# MMC2112

## Advance Information

---

---

To provide the most up-to-date information, the revision of our documents on the World Wide Web will be the most current. Your printed copy may be an earlier revision. To verify you have the latest information available, refer to:

<http://www.motorola.com/semiconductors/>

The following revision history table summarizes changes contained in this document. For your convenience, the page number designators have been linked to the appropriate location.

**Revision History**

Date	Revision Level	Description	Page Number(s)
March, 2002	N/A	Original release	N/A
April, 2002	1.0	<b>Figure 4-4. Chip Identification Register (CIR)</b> — Corrected reset condition for bits 11 and 8	131
		<b>20.9.3 Show Strobe (SHS)</b> — Corrected description in first paragraph	542
		<b>23.5 Junction Temperature Determination</b> — Changed subsection title from Power Dissipation to Junction Temperature Determination	614
		<b>23.7 DC Electrical Specifications</b> — Under operating supply current, external oscillator clocking changed stop mode maximum value from 10 $\mu$ A to 200 $\mu$ A	616
		<b>23.7 DC Electrical Specifications</b> — Under operating supply current, crystal/PLL clock changed maximum value for OSC and PLL disabled from 150 $\mu$ A to 200 $\mu$ A	617
		<b>Appendix A. Security</b> — Updated for clarity	649

## List of Sections

Section 1. General Description .....	45
Section 2. System Memory Map .....	53
Section 3. Signal Description.....	95
Section 4. Chip Configuration Module (CCM) .....	121
Section 5. Reset Controller Module.....	139
Section 6. Power Management .....	155
Section 7. M•CORE M210 Central Processor Unit (CPU) .....	165
Section 8. Interrupt Controller Module .....	177
Section 9. Static Random Access Memory (SRAM).....	199
Section 10. Second Generation FLASH for M•CORE (SGFM) .....	203
Section 11. Clock Module.....	243
Section 12. Ports Module .....	271
Section 13. Edge Port Module (EPORT) .....	285
Section 14. Watchdog Timer Module .....	295
Section 15. Programmable Interrupt Timer Modules (PIT1 and PIT2) .....	305
Section 16. Timer Modules (TIM1 and TIM2).....	317

Section 17. Serial Communications Interface  
Modules (SCI1 and SCI2) .....353

Section 18. Serial Peripheral Interface  
Module (SPI) .....397

Section 19. Queued Analog-to-Digital  
Converter (QADC).....425

Section 20. External Bus Interface Module (EBI) .....527

Section 21. Chip Select Module .....547

Section 22. JTAG Test Access Port and OnCE .....559

Section 23. Preliminary Electrical Specifications .....611

Section 24. Mechanical Specifications .....639

Section 25. Ordering Information .....647

Appendix A. Security .....649

## Table of Contents

### Section 1. General Description

1.1	Contents . . . . .	45
1.2	Introduction . . . . .	45
1.3	Features . . . . .	46
1.4	Block Diagram . . . . .	51

### Section 2. System Memory Map

2.1	Contents . . . . .	53
2.2	Introduction . . . . .	53
2.3	Address Map . . . . .	54
2.4	Register Map . . . . .	57

### Section 3. Signal Description

3.1	Contents . . . . .	95
3.2	Introduction . . . . .	97
3.3	Package Pinout Summary . . . . .	98
3.4	Chip Specific Implementation Signal Issues . . . . .	109
3.4.1	$\overline{\text{RSTOUT}}$ Signal Functions . . . . .	109
3.4.2	$\overline{\text{INT}}$ Signal Functions . . . . .	110
3.4.3	Serial Peripheral Interface (SPI) Pin Functions . . . . .	110
3.4.4	Serial Communications Interface (SCI1 and SCI2) Pin Functions . . . . .	111
3.4.5	Timer 1 and Timer 2 Pin Functions . . . . .	112
3.4.6	Queued Analog-to-Digital Converter (QADC) Pin Functions . . . . .	112

3.5	Signal Descriptions .....	113
3.5.1	Reset Signals .....	113
3.5.1.1	Reset In ( <u>RESET</u> ) .....	113
3.5.1.2	Reset Out ( <u>RSTOUT</u> ) .....	113
3.5.2	Phase-Lock Loop (PLL) and Clock Signals .....	113
3.5.2.1	External Clock In (EXTAL) .....	113
3.5.2.2	Crystal (XTAL) .....	114
3.5.2.3	Clock Out (CLKOUT) .....	114
3.5.2.4	PLL Enable (PLLEN) .....	114
3.5.3	External Memory Interface Signals .....	114
3.5.3.1	Data Bus (D[31:0]) .....	114
3.5.3.2	Show Cycle Strobe ( <u>SHS</u> ) .....	114
3.5.3.3	Transfer Acknowledge ( <u>TA</u> ) .....	115
3.5.3.4	Transfer Error Acknowledge ( <u>TEA</u> ) .....	115
3.5.3.5	Emulation Mode Chip Selects (CSE[1:0]) .....	115
3.5.3.6	Transfer Code (TC[2:0]) .....	115
3.5.3.7	Read/Write (R/ <u>W</u> ) .....	115
3.5.3.8	Address Bus ( <u>A</u> [22:0]) .....	115
3.5.3.9	Enable Byte ( <u>EB</u> [3:0]) .....	116
3.5.3.10	Chip Select ( <u>CS</u> [3:0]) .....	116
3.5.3.11	Output Enable ( <u>OE</u> ) .....	116
3.5.4	Edge Port Signals .....	116
3.5.4.1	External Interrupts ( <u>INT</u> [7:6]) .....	116
3.5.4.2	External Interrupts ( <u>INT</u> [5:2]) .....	116
3.5.4.3	External Interrupts ( <u>INT</u> [1:0]) .....	116
3.5.5	Serial Peripheral Interface Module Signals .....	117
3.5.5.1	Master Out/Slave In (MOSI) .....	117
3.5.5.2	Master In/Slave Out (MISO) .....	117
3.5.5.3	Serial Clock ( <u>SCK</u> ) .....	117
3.5.5.4	Slave Select ( <u>SS</u> ) .....	117
3.5.6	Serial Communications Interface Module Signals .....	117
3.5.6.1	Receive Data (RXD1 and RXD2) .....	117
3.5.6.2	Transmit Data (TXD1 and TXD2) .....	118
3.5.7	Timer Signals (ICOC1[3:0] and ICOC2[3:0]) .....	118



3.5.8	Analog-to-Digital Converter Signals . . . . .	118
3.5.8.1	Analog Inputs (PQA[4:3], PQA[1:0], and PQB[3:0]) . . . . .	118
3.5.8.2	Analog Reference ( $V_{RH}$ and $V_{RL}$ ) . . . . .	118
3.5.8.3	Analog Supply ( $V_{DDA}$ and $V_{SSA}$ ) . . . . .	118
3.5.8.4	Positive Supply ( $V_{DDH}$ ) . . . . .	118
3.5.9	Debug and Emulation Support Signals . . . . .	119
3.5.9.1	Test Reset (TRST) . . . . .	119
3.5.9.2	Test Clock (TCLK) . . . . .	119
3.5.9.3	Test Mode Select (TMS) . . . . .	119
3.5.9.4	Test Data Input (TDI) . . . . .	119
3.5.9.5	Test Data Output (TDO) . . . . .	119
3.5.9.6	Debug Event (DE) . . . . .	119
3.5.10	Test Signal (TEST) . . . . .	120
3.5.11	Power and Ground Signals . . . . .	120
3.5.11.1	Standby Power ( $V_{STBY}$ ) . . . . .	120
3.5.11.2	Positive Supply ( $V_{DD}$ ) . . . . .	120
3.5.11.3	Ground ( $V_{SS}$ ) . . . . .	120

**Section 4. Chip Configuration Module (CCM)**

4.1	Contents . . . . .	121
4.2	Introduction . . . . .	122
4.3	Features . . . . .	122
4.4	Modes of Operation . . . . .	122
4.4.1	Master Mode . . . . .	123
4.4.2	Single-Chip Mode . . . . .	123
4.4.3	Emulation Mode . . . . .	123
4.4.4	Factory Access Slave Test (FAST) Mode . . . . .	123
4.5	Block Diagram . . . . .	124
4.6	Signal Descriptions . . . . .	124
4.7	Memory Map and Registers . . . . .	125
4.7.1	Programming Model . . . . .	125
4.7.2	Memory Map . . . . .	126
4.7.3	Register Descriptions . . . . .	126
4.7.3.1	Chip Configuration Register . . . . .	126
4.7.3.2	Reset Configuration Register . . . . .	129
4.7.3.3	Chip Identification Register . . . . .	131
4.7.3.4	Chip Test Register . . . . .	132

4.8	Functional Description .....	133
4.8.1	Reset Configuration .....	133
4.8.2	Chip Mode Selection .....	135
4.8.3	Boot Device Selection .....	135
4.8.4	Output Pad Strength Configuration .....	137
4.8.5	Clock Mode Selection .....	137
4.8.6	Internal FLASH Configuration .....	138
4.9	Reset .....	138
4.10	Interrupts .....	138

### Section 5. Reset Controller Module

5.1	Contents .....	139
5.2	Overview .....	140
5.3	Features .....	140
5.4	Block Diagram .....	141
5.5	Signals .....	141
5.5.1	<u>RESET</u> .....	142
5.5.2	<u>RSTOUT</u> .....	142
5.6	Memory Map and Registers .....	142
5.6.1	Reset Control Register .....	143
5.6.2	Reset Status Register .....	145
5.7	Functional Description .....	147
5.7.1	Reset Sources .....	147
5.7.1.1	Power-On Reset .....	148
5.7.1.2	External Reset .....	148
5.7.1.3	Watchdog Timer Reset .....	148
5.7.1.4	Loss of Clock Reset .....	148
5.7.1.5	Loss of Lock Reset .....	149
5.7.1.6	Software Reset .....	149
5.7.1.7	LVD Reset .....	149
5.7.2	Reset Control Flow .....	149
5.7.2.1	Synchronous Reset Requests .....	151
5.7.2.2	Internal Reset Request .....	151
5.7.2.3	Power-On Reset/Low-Voltage Detect Reset .....	151

5.7.3 Concurrent Resets ..... 152  
 5.7.3.1 Reset Flow ..... 152  
 5.7.3.2 Reset Status Flags ..... 152

**Section 6. Power Management**

6.1 Contents ..... 155  
 6.2 Introduction ..... 156  
 6.3 Low-Power Modes ..... 156  
 6.3.1 Run Mode ..... 156  
 6.3.2 Wait Mode ..... 157  
 6.3.3 Doze Mode ..... 157  
 6.3.4 Stop Mode ..... 157  
 6.3.5 Peripheral Shut Down ..... 157  
 6.4 Peripheral Behavior in Low-Power Modes ..... 158  
 6.4.1 Reset ..... 158  
 6.4.2 Clocks ..... 158  
 6.4.3 OnCE ..... 159  
 6.4.4 JTAG ..... 160  
 6.4.5 Interrupt Controller ..... 160  
 6.4.6 Edge Port ..... 160  
 6.4.7 Random-Access Memory (RAM) ..... 160  
 6.4.8 FLASH ..... 161  
 6.4.9 Queued Analog-to-Digital Converter (QADC) ..... 161  
 6.4.10 Watchdog Timer ..... 161  
 6.4.11 Programmable Interrupt Timers (PIT1 and PIT2) ..... 162  
 6.4.12 Serial Peripheral Interface (SPI) ..... 162  
 6.4.13 Serial Communication Interfaces (SCI1 and SCI2) ..... 162  
 6.4.14 Timers (TIM1 and TIM2) ..... 163  
 6.5 Summary of Peripheral State During Low-Power Modes ..... 163

**Section 7. M•CORE M210 Central Processor Unit (CPU)**

7.1 Contents ..... 165  
 7.2 Introduction ..... 165  
 7.3 Features ..... 166  
 7.4 Microarchitecture Summary ..... 167

7.5	Programming Model . . . . .	169
7.6	Data Format Summary . . . . .	171
7.7	Operand Addressing Capabilities . . . . .	172
7.8	Instruction Set Overview . . . . .	172

**Section 8. Interrupt Controller Module**

8.1	Contents . . . . .	177
8.2	Introduction . . . . .	178
8.3	Features . . . . .	178
8.4	Low-Power Mode Operation . . . . .	178
8.5	Block Diagram . . . . .	179
8.6	External Signals . . . . .	179
8.7	Memory Map and Registers . . . . .	179
8.7.1	Memory Map . . . . .	180
8.7.2	Registers . . . . .	181
8.7.2.1	Interrupt Control Register . . . . .	181
8.7.2.2	Interrupt Status Register . . . . .	183
8.7.2.3	Interrupt Force Registers . . . . .	184
8.7.2.4	Interrupt Pending Register . . . . .	186
8.7.2.5	Normal Interrupt Enable Register . . . . .	187
8.7.2.6	Normal Interrupt Pending Register . . . . .	188
8.7.2.7	Fast Interrupt Enable Register . . . . .	189
8.7.2.8	Fast Interrupt Pending Register . . . . .	190
8.7.2.9	Priority Level Select Registers . . . . .	191
8.8	Functional Description . . . . .	191
8.8.1	Interrupt Sources and Prioritization . . . . .	192
8.8.2	Fast and Normal Interrupt Requests . . . . .	192
8.8.3	Autovectored and Vectored Interrupt Requests . . . . .	193
8.8.4	Interrupt Configuration . . . . .	195
8.8.4.1	CPU Configuration . . . . .	195
8.8.4.2	Interrupt Controller Configuration . . . . .	195
8.8.4.3	Interrupt Source Configuration . . . . .	196
8.8.5	Interrupts . . . . .	196

**Section 9. Static Random Access Memory (SRAM)**

9.1	Contents . . . . .	199
9.2	Introduction . . . . .	199
9.3	Modes of Operation . . . . .	200
9.4	Low-Power Modes . . . . .	200
9.5	Standby Power Supply Pin ( $V_{STBY}$ ) . . . . .	200
9.6	Standby Operation . . . . .	200
9.7	Reset Operation . . . . .	201
9.8	Interrupts . . . . .	201

**Section 10. Second Generation FLASH  
for M•CORE (SGFM)**

10.1	Contents . . . . .	203
10.2	Introduction . . . . .	204
10.3	Glossary . . . . .	205
10.4	Features . . . . .	206
10.5	Modes of Operation . . . . .	206
10.6	Block Diagram . . . . .	207
10.7	Module Memory Map . . . . .	209
10.7.1	Unbanked Register Descriptions . . . . .	213
10.7.1.1	SGFM Configuration Register . . . . .	213
10.7.1.2	SGFM Clock Divider Register . . . . .	215
10.7.1.3	SGFM Test Register . . . . .	216
10.7.1.4	SGFM Security Register . . . . .	217
10.7.1.5	SGFM Monitor Data Register . . . . .	219
10.7.2	Banked Register Descriptions . . . . .	220
10.7.2.1	SGFM Protection Register . . . . .	220
10.7.2.2	SGFM Supervisor Access Register . . . . .	222
10.7.2.3	SGFM Data Access Register . . . . .	223
10.7.2.4	SGFM Test Status Register . . . . .	224
10.7.2.5	SGFM User Status Register . . . . .	224
10.7.2.6	SGFM Command Register . . . . .	226
10.7.2.7	SGFM Control Register . . . . .	227
10.7.2.8	SGFM Address Register . . . . .	228
10.7.2.9	SGFM Data Register . . . . .	229

10.8	SGFM User Mode	230
10.8.1	Read Operations	230
10.8.2	Write Operations	230
10.8.3	Program and Erase Operations	231
10.8.3.1	Setting the SGFMCLKD Register	231
10.8.3.2	Program, Erase, and Verify Sequences	232
10.8.3.3	FLASH User Mode Valid Commands	234
10.8.3.4	FLASH User Mode Illegal Operations	236
10.8.4	Stop Mode	237
10.8.5	Master Mode	238
10.8.6	Emulation Mode	238
10.8.7	Debug Mode	238
10.9	FLASH Security Operation	238
10.9.1	Back Door Access	239
10.9.2	Erase Verify Check	239
10.10	Resets	240
10.11	Interrupts	240

**Section 11. Clock Module**

11.1	Contents	243
11.2	Introduction	244
11.3	Features	244
11.4	Modes of Operation	245
11.4.1	Normal PLL Mode	245
11.4.2	1:1 PLL Mode	245
11.4.3	External Clock Mode	245
11.4.4	Low-Power Options	245
11.4.4.1	Wait and Doze Modes	245
11.4.4.2	Stop Mode	246
11.5	Block Diagram	247
11.6	Signal Descriptions	248
11.6.1	EXTAL	248
11.6.2	XTAL	248
11.6.3	CLKOUT	248
11.6.4	PLEN	248
11.6.5	RSTOUT	249

- 11.7 Memory Map and Registers .....249
  - 11.7.1 Module Memory Map .....249
  - 11.7.2 Register Descriptions .....250
    - 11.7.2.1 Synthesizer Control Register .....250
    - 11.7.2.2 Synthesizer Status Register .....253
    - 11.7.2.3 Synthesizer Test Register .....256
    - 11.7.2.4 Synthesizer Test Register 2 .....257
- 11.8 Functional Description .....258
  - 11.8.1 System Clock Modes .....258
  - 11.8.2 System Clocks Generation .....259
  - 11.8.3 PLL Lock Detection .....259
    - 11.8.3.1 PLL Loss of Lock Conditions .....261
    - 11.8.3.2 PLL Loss of Lock Reset .....261
  - 11.8.4 Loss of Clock Detection .....261
    - 11.8.4.1 Alternate Clock Selection .....262
    - 11.8.4.2 Loss-of-Clock Reset .....265
  - 11.8.5 Clock Operation During Reset .....266
  - 11.8.6 PLL Operation .....266
    - 11.8.6.1 Phase and Frequency Detector (PFD) .....268
    - 11.8.6.2 Charge Pump/Loop Filter .....268
    - 11.8.6.3 Voltage Control Output (VCO) .....269
    - 11.8.6.4 Multiplication Factor Divider (MFD) .....269
- 11.9 Reset .....269
- 11.10 Interrupts .....269

**Section 12. Ports Module**

- 12.1 Contents .....271
- 12.2 Introduction .....272
- 12.3 Signals .....273
- 12.4 Memory Map and Registers .....273
  - 12.4.1 Memory Map .....274
  - 12.4.2 Register Descriptions .....275
    - 12.4.2.1 Port Output Data Registers .....275
    - 12.4.2.2 Port Data Direction Registers .....276
    - 12.4.2.3 Port Pin Data/Set Data Registers .....277
    - 12.4.2.4 Port Clear Output Data Registers .....278

12.4.2.5 Port C/D Pin Assignment Register . . . . . 279

12.4.2.6 Port E Pin Assignment Register . . . . . 280

12.5 Functional Description . . . . . 281

12.5.1 Pin Functions . . . . . 282

12.5.2 Port Digital I/O Timing . . . . . 283

12.6 Interrupts . . . . . 283

**Section 13. Edge Port Module (EPORT)**

13.1 Contents . . . . . 285

13.2 Introduction . . . . . 285

13.3 Low-Power Mode Operation . . . . . 286

13.3.1 Wait and Doze Modes . . . . . 286

13.3.2 Stop Mode . . . . . 287

13.4 Interrupt/General-Purpose I/O Pin Descriptions . . . . . 287

13.5 Memory Map and Registers . . . . . 287

13.5.1 Memory Map . . . . . 287

13.5.2 Registers . . . . . 288

13.5.2.1 EPORT Pin Assignment Register . . . . . 288

13.5.2.2 EPORT Data Direction Register . . . . . 290

13.5.2.3 Edge Port Interrupt Enable Register . . . . . 291

13.5.2.4 Edge Port Data Register . . . . . 292

13.5.2.5 Edge Port Pin Data Register . . . . . 292

13.5.2.6 Edge Port Flag Register . . . . . 293

**Section 14. Watchdog Timer Module**

14.1 Contents . . . . . 295

14.2 Introduction . . . . . 295

14.3 Modes of Operation . . . . . 296

14.3.1 Wait Mode . . . . . 296

14.3.2 Doze Mode . . . . . 296

14.3.3 Stop Mode . . . . . 296

14.3.4 Debug Mode . . . . . 296

14.4 Block Diagram . . . . . 297

14.5 Signals . . . . . 297

14.6 Memory Map and Registers . . . . . 298



14.6.1	Memory Map .....	298
14.6.2	Registers .....	298
14.6.2.1	Watchdog Control Register .....	299
14.6.2.2	Watchdog Modulus Register .....	301
14.6.2.3	Watchdog Count Register .....	302
14.6.2.4	Watchdog Service Register .....	303

**Section 15. Programmable Interrupt Timer Modules  
(PIT1 and PIT2)**

15.1	Contents .....	305
15.2	Introduction .....	306
15.3	Block Diagram .....	306
15.4	Modes of Operation .....	307
15.4.1	Wait Mode .....	307
15.4.2	Doze Mode .....	307
15.4.3	Stop Mode .....	307
15.4.4	Debug Mode .....	307
15.5	Signals .....	307
15.6	Memory Map and Registers .....	308
15.6.1	Memory Map .....	308
15.6.2	Registers .....	308
15.6.2.1	PIT Control and Status Register .....	309
15.6.2.2	PIT Modulus Register .....	312
15.6.2.3	PIT Count Register .....	313
15.7	Functional Description .....	314
15.7.1	Set-and-Forget Timer Operation .....	314
15.7.2	Free-Running Timer Operation .....	315
15.7.3	Timeout Specifications .....	315
15.8	Interrupt Operation .....	316

**Section 16. Timer Modules (TIM1 and TIM2)**

16.1	Contents .....	317
16.2	Introduction .....	319
16.3	Features .....	319
16.4	Block Diagram .....	320

16.5	Modes of Operation .....	321
16.5.1	Supervisor and User Modes.....	321
16.5.2	Run Mode.....	321
16.5.3	Stop Mode .....	321
16.5.4	Wait, Doze, and Debug Modes .....	321
16.5.5	Test Mode .....	322
16.6	Signal Description.....	322
16.6.1	ICOC[2:0] .....	322
16.6.2	ICOC3 .....	322
16.7	Memory Map and Registers .....	323
16.7.1	Timer Input Capture/Output Compare Select Register ...	324
16.7.2	Timer Compare Force Register .....	325
16.7.3	Timer Output Compare 3 Mask Register .....	326
16.7.4	Timer Output Compare 3 Data Register.....	327
16.7.5	Timer Counter Registers .....	328
16.7.6	Timer System Control Register 1 .....	329
16.7.7	Timer Toggle-On-Overflow Register .....	330
16.7.8	Timer Control Register 1 .....	331
16.7.9	Timer Control Register 2 .....	332
16.7.10	Timer Interrupt Enable Register .....	333
16.7.11	Timer System Control Register 2 .....	334
16.7.12	Timer Flag Register 1 .....	336
16.7.13	Timer Flag Register 2 .....	337
16.7.14	Timer Channel Registers .....	338
16.7.15	Pulse Accumulator Control Register .....	339
16.7.16	Pulse Accumulator Flag Register .....	341
16.7.17	Pulse Accumulator Counter Registers .....	342
16.7.18	Timer Port Data Register .....	343
16.7.19	Timer Port Data Direction Register .....	344
16.7.20	Timer Test Register .....	345
16.8	Functional Description .....	345
16.8.1	Prescaler .....	345
16.8.2	Input Capture .....	345
16.8.3	Output Compare .....	346
16.8.4	Pulse Accumulator .....	347
16.8.4.1	Event Counter Mode .....	347
16.8.4.2	Gated Time Accumulation Mode .....	348

16.8.5 General-Purpose I/O Ports ..... 349

16.9 Reset ..... 351

16.10 Interrupts ..... 351

16.10.1 Timer Channel Interrupts (CxF) ..... 351

16.10.2 Pulse Accumulator Overflow (PAOVF)..... 352

16.10.3 Pulse Accumulator Input (PAIF) ..... 352

16.10.4 Timer Overflow (TOF) ..... 352

**Section 17. Serial Communications Interface Modules  
(SCI1 and SCI2)**

17.1 Contents ..... 353

17.2 Introduction ..... 354

17.3 Features ..... 355

17.4 Block Diagram ..... 356

17.5 Modes of Operation ..... 357

17.5.1 Doze Mode ..... 357

17.5.2 Stop Mode ..... 357

17.6 Signal Description ..... 358

17.6.1 RXD ..... 358

17.6.2 TXD ..... 358

17.7 Memory Map and Registers ..... 358

17.7.1 SCI Baud Rate Registers ..... 360

17.7.2 SCI Control Register 1 ..... 361

17.7.3 SCI Control Register 2 ..... 364

17.7.4 SCI Status Register 1 ..... 366

17.7.5 SCI Status Register 2 ..... 369

17.7.6 SCI Data Registers ..... 370

17.7.7 SCI Pullup and Reduced Drive Register ..... 371

17.7.8 SCI Port Data Register ..... 372

17.7.9 SCI Data Direction Register ..... 373

17.8 Functional Description ..... 374

17.9 Data Format ..... 374

17.10 Baud Rate Generation ..... 375

17.11 Transmitter ..... 376

17.11.1 Frame Length ..... 377

- 17.11.2 Transmitting a Frame ..... 378
- 17.11.3 Break Frames..... 380
- 17.11.4 Idle Frames ..... 380
- 17.12 Receiver ..... 381
- 17.12.1 Frame Length..... 381
- 17.12.2 Receiving a Frame ..... 381
- 17.12.3 Data Sampling ..... 382
- 17.12.4 Framing Errors ..... 387
- 17.12.5 Baud Rate Tolerance ..... 387
- 17.12.5.1 Slow Data Tolerance ..... 388
- 17.12.5.2 Fast Data Tolerance ..... 389
- 17.12.6 Receiver Wakeup..... 390
- 17.12.6.1 Idle Input Line Wakeup (WAKE = 0) ..... 390
- 17.12.6.2 Address Mark Wakeup (WAKE = 1)..... 391
- 17.13 Single-Wire Operation ..... 392
- 17.14 Loop Operation..... 393
- 17.15 I/O Ports ..... 394
- 17.16 Reset ..... 395
- 17.17 Interrupts..... 395
- 17.17.1 Transmit Data Register Empty ..... 395
- 17.17.2 Transmission Complete ..... 395
- 17.17.3 Receive Data Register Full..... 396
- 17.17.4 Idle Receiver Input ..... 396
- 17.17.5 Overrun ..... 396

**Section 18. Serial Peripheral Interface Module (SPI)**

- 18.1 Contents ..... 397
- 18.2 Introduction..... 398
- 18.3 Features ..... 398
- 18.4 Modes of Operation ..... 399
- 18.5 Block Diagram ..... 399
- 18.6 Signal Description..... 400
- 18.6.1 MISO (Master In/Slave Out)..... 400
- 18.6.2 MOSI (Master Out/Slave In)..... 400
- 18.6.3 SCK (Serial Clock) ..... 401
- 18.6.4  $\overline{SS}$  (Slave Select)..... 401

18.7	Memory Map and Registers	401
18.7.1	SPI Control Register 1	402
18.7.2	SPI Control Register 2	405
18.7.3	SPI Baud Rate Register	406
18.7.4	SPI Status Register	408
18.7.5	SPI Data Register	409
18.7.6	SPI Pullup and Reduced Drive Register	410
18.7.7	SPI Port Data Register	411
18.7.8	SPI Port Data Direction Register	412
18.8	Functional Description	413
18.8.1	Master Mode	414
18.8.2	Slave Mode	415
18.8.3	Transmission Formats	416
18.8.3.1	Transfer Format When CPHA = 1	416
18.8.3.2	Transfer Format When CPHA = 0	417
18.8.4	SPI Baud Rate Generation	420
18.8.5	Slave-Select Output	420
18.8.6	Bidirectional Mode	421
18.8.7	Error Conditions	422
18.8.7.1	Write Collision Error	422
18.8.7.2	Mode Fault Error	422
18.8.8	Low-Power Mode Options	423
18.8.8.1	Run Mode	423
18.8.8.2	Doze Mode	423
18.8.8.3	Stop Mode	424
18.9	Reset	424
18.10	Interrupts	424
18.10.1	Mode Fault (MODF) Flag	424
18.10.2	SPI Interrupt Flag (SPIF)	424

**Section 19. Queued Analog-to-Digital Converter (QADC)**

19.1	Contents	425
19.2	Introduction	427
19.3	Features	428
19.4	Block Diagram	429

19.5	Modes of Operation .....	430
19.5.1	Debug Mode .....	430
19.5.2	Stop Mode .....	431
19.6	Signals .....	431
19.6.1	Port QA Pin Functions .....	432
19.6.1.1	Port QA Analog Input Pins .....	432
19.6.1.2	Port QA Digital Input/Output Pins .....	433
19.6.2	Port QB Pin Functions .....	433
19.6.2.1	Port QB Analog Input Pins .....	433
19.6.2.2	Port QB Digital Input Pins .....	433
19.6.3	External Trigger Input Pins .....	434
19.6.4	Multiplexed Address Output Pins .....	434
19.6.5	Multiplexed Analog Input Pins .....	435
19.6.6	Voltage Reference Pins .....	435
19.6.7	Dedicated Analog Supply Pins .....	435
19.6.8	Dedicated Digital I/O Port Supply Pin .....	435
19.7	Memory Map .....	436
19.8	Register Descriptions .....	437
19.8.1	QADC Module Configuration Register (QADCMCR) .....	437
19.8.2	QADC Test Register (QADCTEST) .....	438
19.8.3	Port Data Registers (PORTQA and PORTQB) .....	438
19.8.4	Port QA and QB Data Direction Register (DDRQA and DDRQB) .....	440
19.8.5	Control Registers .....	442
19.8.5.1	QADC Control Register 0 (QACR0) .....	442
19.8.5.2	QADC Control Register 1 (QACR1) .....	445
19.8.5.3	QADC Control Register 2 (QACR2) .....	448
19.8.6	Status Registers .....	453
19.8.6.1	QADC Status Register 0 (QASR0) .....	453
19.8.6.2	QADC Status Register 1 (QASR1) .....	462
19.8.7	Conversion Command Word Table (CCW) .....	463
19.8.8	Result Registers .....	468
19.8.8.1	Right-Justified Unsigned Result Register (RJURR) .....	468
19.8.8.2	Left-Justified Signed Result Register (LJSRR) .....	469
19.8.8.3	Left-Justified Unsigned Result Register (LJURR) .....	470

- 19.9 Functional Description ..... 470
- 19.9.1 Result Coherency ..... 470
- 19.9.2 External Multiplexing ..... 471
- 19.9.2.1 External Multiplexing Operation ..... 471
- 19.9.2.2 Module Version Options ..... 473
- 19.9.3 Analog Subsystem ..... 474
- 19.9.3.1 Analog-to-Digital Converter Operation ..... 474
- 19.9.3.2 Conversion Cycle Times ..... 475
- 19.9.3.3 Channel Decode and Multiplexer ..... 476
- 19.9.3.4 Sample Buffer ..... 476
- 19.9.3.5 Digital-to-Analog Converter (DAC) Array ..... 476
- 19.9.3.6 Comparator ..... 477
- 19.9.3.7 Bias ..... 477
- 19.9.3.8 Successive Approximation Register ..... 477
- 19.9.3.9 State Machine ..... 477
- 19.10 Digital Control ..... 478
- 19.10.1 Queue Priority Timing Examples ..... 478
- 19.10.1.1 Queue Priority ..... 478
- 19.10.1.2 Queue Priority Schemes ..... 481
- 19.10.2 Boundary Conditions ..... 492
- 19.10.3 Scan Modes ..... 493
- 19.10.4 Disabled Mode ..... 494
- 19.10.5 Reserved Mode ..... 494
- 19.10.6 Single-Scan Modes ..... 494
- 19.10.6.1 Software-Initiated Single-Scan Mode ..... 495
- 19.10.6.2 Externally Triggered Single-Scan Mode ..... 496
- 19.10.6.3 Externally Gated Single-Scan Mode ..... 497
- 19.10.6.4 Interval Timer Single-Scan Mode ..... 497
- 19.10.7 Continuous-Scan Modes ..... 499
- 19.10.7.1 Software-Initiated Continuous-Scan Mode ..... 500
- 19.10.7.2 Externally Triggered Continuous-Scan Mode ..... 501
- 19.10.7.3 Externally Gated Continuous-Scan Mode ..... 501
- 19.10.7.4 Periodic Timer Continuous-Scan Mode ..... 502
- 19.10.8 QADC Clock (QCLK) Generation ..... 503
- 19.10.9 Periodic/Interval Timer ..... 504
- 19.10.10 Conversion Command Word Table ..... 505
- 19.10.11 Result Word Table ..... 509

- 19.11 Pin Connection Considerations ..... 509
- 19.11.1 Analog Reference Pins..... 509
- 19.11.2 Analog Power Pins..... 510
- 19.11.3 Conversion Timing Schemes..... 512
- 19.11.4 Analog Supply Filtering and Grounding..... 515
- 19.11.5 Accommodating Positive/Negative Stress Conditions... 517
- 19.11.6 Analog Input Considerations..... 519
- 19.11.7 Analog Input Pins..... 521
- 19.11.7.1 Settling Time for the External Circuit..... 522
- 19.11.7.2 Error Resulting from Leakage..... 523
- 19.12 Interrupts..... 524
- 19.12.1 Interrupt Operation..... 524
- 19.12.2 Interrupt Sources..... 525

**Section 20. External Bus Interface Module (EBI)**

- 20.1 Contents..... 527
- 20.2 Introduction..... 528
- 20.3 Signal Descriptions..... 529
- 20.3.1 Data Bus (D[31:0])..... 530
- 20.3.2 Show Cycle Strobe ( $\overline{\text{SHS}}$ )..... 530
- 20.3.3 Transfer Acknowledge ( $\overline{\text{TA}}$ )..... 530
- 20.3.4 Transfer Error Acknowledge ( $\overline{\text{TEA}}$ )..... 530
- 20.3.5 Emulation Mode Chip Selects (CSE[1:0])..... 530
- 20.3.6 Transfer Code (TC[2:0])..... 531
- 20.3.7 Read/Write (R/W)..... 531
- 20.3.8 Address Bus (A[22:0])..... 531
- 20.3.9 Enable Byte ( $\overline{\text{EB}}[3:0]$ )..... 531
- 20.3.10 Chip Selects (CS[3:0])..... 531
- 20.3.11 Output Enable ( $\overline{\text{OE}}$ )..... 531
- 20.3.12 Transfer Size (TSIZ[1:0])..... 532
- 20.3.13 Processor Status (PSTAT[3:0])..... 532
- 20.4 Memory Map and Registers..... 532
- 20.5 Operand Transfer..... 532
- 20.6 Enable Byte Pins ( $\overline{\text{EB}}[3:0]$ )..... 534



20.7	Bus Master Cycles . . . . .	534
20.7.1	Read Cycles . . . . .	535
20.7.1.1	State 1 (X1) . . . . .	536
20.7.1.2	Optional Wait States (X2W) . . . . .	536
20.7.1.3	State 2 (X2) . . . . .	536
20.7.2	Write Cycles . . . . .	537
20.7.2.1	State 1 (X1) . . . . .	538
20.7.2.2	Optional Wait States (X2W) . . . . .	538
20.7.2.3	State 2 (X2) . . . . .	538
20.8	Bus Exception Operation . . . . .	540
20.8.1	Transfer Error Termination . . . . .	540
20.8.2	Transfer Abort Termination . . . . .	540
20.9	Emulation Support . . . . .	540
20.9.1	Emulation Chip-Selects (CSE[1:0]) . . . . .	540
20.9.2	Internal Data Transfer Display (Show Cycles) . . . . .	541
20.9.3	Show Strobe ( $\overline{\text{SHS}}$ ) . . . . .	542
20.9.4	Transfer Code (TC[2:0]) . . . . .	543
20.9.5	Processor Status (PSTAT) . . . . .	543
20.10	Bus Monitor . . . . .	545
20.11	Interrupts . . . . .	545

**Section 21. Chip Select Module**

21.1	Contents . . . . .	547
21.2	Introduction . . . . .	547
21.3	Features . . . . .	548
21.4	Block Diagram . . . . .	549
21.5	Signals . . . . .	550
21.6	Memory Map and Registers . . . . .	550
21.6.1	Memory Map . . . . .	550
21.6.2	Registers . . . . .	551
21.7	Functional Description . . . . .	556
21.8	Interrupts . . . . .	557

**Section 22. JTAG Test Access Port and OnCE**

22.1	Contents . . . . .	559
22.2	Introduction . . . . .	561
22.3	Top-Level Test Access Port (TAP) . . . . .	563
22.3.1	Test Clock (TCLK) . . . . .	564
22.3.2	Test Mode Select (TMS) . . . . .	564
22.3.3	Test Data Input (TDI) . . . . .	564
22.3.4	Test Data Output (TDO) . . . . .	564
22.3.5	Test Reset (TRST) . . . . .	564
22.3.6	Debug Event (DE) . . . . .	564
22.4	Top-Level TAP Controller . . . . .	566
22.5	Instruction Shift Register . . . . .	567
22.5.1	EXTEST Instruction . . . . .	567
22.5.2	IDCODE Instruction . . . . .	568
22.5.3	SAMPLE/PRELOAD Instruction . . . . .	569
22.5.4	ENABLE_MCU_ONCE Instruction . . . . .	569
22.5.5	HIGHZ Instruction . . . . .	570
22.5.6	CLAMP Instruction . . . . .	570
22.5.7	BYPASS Instruction . . . . .	570
22.6	IDCODE Register . . . . .	571
22.7	Bypass Register . . . . .	572
22.8	Boundary Scan Register . . . . .	572
22.9	Restrictions . . . . .	572
22.10	Non-Scan Chain Operation . . . . .	573
22.11	Boundary Scan . . . . .	573
22.12	Low-Level TAP (OnCE) Module . . . . .	579
22.13	Signal Descriptions . . . . .	581
22.13.1	Debug Serial Input (TDI) . . . . .	581
22.13.2	Debug Serial Clock (TCLK) . . . . .	581
22.13.3	Debug Serial Output (TDO) . . . . .	581
22.13.4	Debug Mode Select (TMS) . . . . .	582
22.13.5	Test Reset ( $\overline{\text{TRST}}$ ) . . . . .	582
22.13.6	Debug Event ( $\overline{\text{DE}}$ ) . . . . .	582

22.14	Functional Description .....	582
22.14.1	Operation .....	583
22.14.2	OnCE Controller and Serial Interface.....	584
22.14.3	OnCE Interface Signals .....	585
22.14.3.1	Internal Debug Request Input ( $\overline{\text{IDR}}$ ) .....	585
22.14.3.2	CPU Debug Request ( $\overline{\text{DBGGRQ}}$ ).....	586
22.14.3.3	CPU Debug Acknowledge ( $\overline{\text{DBGACK}}$ ).....	586
22.14.3.4	CPU Breakpoint Request ( $\overline{\text{BRKRQ}}$ ).....	586
22.14.3.5	CPU Address, Attributes ( $\overline{\text{ADDR}}$ , $\overline{\text{ATTR}}$ ).....	587
22.14.3.6	CPU Status ( $\overline{\text{PSTAT}}$ ) .....	587
22.14.3.7	OnCE Debug Output ( $\overline{\text{DEBUG}}$ ) .....	587
22.14.4	OnCE Controller Registers.....	587
22.14.4.1	OnCE Command Register .....	588
22.14.4.2	OnCE Control Register .....	590
22.14.4.3	OnCE Status Register .....	594
22.14.5	OnCE Decoder (ODEC).....	596
22.14.6	Memory Breakpoint Logic.....	596
22.14.6.1	Memory Address Latch (MAL) .....	597
22.14.6.2	Breakpoint Address Base Registers .....	597
22.14.7	Breakpoint Address Mask Registers .....	597
22.14.7.1	Breakpoint Address Comparators .....	598
22.14.7.2	Memory Breakpoint Counters .....	598
22.14.8	OnCE Trace Logic .....	598
22.14.8.1	OnCE Trace Counter .....	599
22.14.8.2	Trace Operation.....	600
22.14.9	Methods of Entering Debug Mode .....	600
22.14.9.1	Debug Request During RESET .....	600
22.14.9.2	Debug Request During Normal Activity .....	601
22.14.9.3	Debug Request During Stop, Doze, or Wait Mode ...	601
22.14.9.4	Software Request During Normal Activity .....	601
22.14.10	Enabling OnCE Trace Mode .....	601
22.14.11	Enabling OnCE Memory Breakpoints.....	602
22.14.12	Pipeline Information and Write-Back Bus Register .....	602
22.14.12.1	Program Counter Register.....	603
22.14.12.2	Instruction Register .....	603
22.14.12.3	Control State Register .....	603
22.14.12.4	Writeback Bus Register .....	605

22.14.12.5 Processor Status Register . . . . . 605  
 22.14.13 Instruction Address FIFO Buffer (PC FIFO) . . . . . 606  
 22.14.14 Reserved Test Control Registers . . . . . 607  
 22.14.15 Serial Protocol . . . . . 607  
 22.14.16 OnCE Commands . . . . . 608  
 22.14.17 Target Site Debug System Requirements . . . . . 608  
 22.14.18 Interface Connector for JTAG/OnCE Serial Port . . . . . 608

**Section 23. Preliminary Electrical Specifications**

23.1 Contents . . . . . 611  
 23.2 Introduction . . . . . 612  
 23.3 Absolute Maximum Ratings . . . . . 613  
 23.4 Thermal Characteristics . . . . . 614  
 23.5 Junction Temperature Determination . . . . . 614  
 23.6 Electrostatic Discharge (ESD) Protection . . . . . 615  
 23.7 DC Electrical Specifications . . . . . 616  
 23.8 PLL Electrical Specifications . . . . . 618  
 23.9 QADC Electrical Characteristics . . . . . 620  
 23.10 FLASH Memory Characteristics . . . . . 624  
 23.11 External Interface Timing Characteristics . . . . . 625  
 23.12 General Purpose I/O Timing . . . . . 630  
 23.13 Reset and Configuration Override Timing . . . . . 631  
 23.14 SPI Timing Characteristics . . . . . 632  
 23.15 OnCE, JTAG, and Boundary Scan Timing . . . . . 635

**Section 24. Mechanical Specifications**

24.2 Introduction . . . . . 639  
 24.3 Bond Pins . . . . . 640  
 24.4 Package Information for the 144-Pin LQFP . . . . . 641  
 24.5 Package Information for the 100-Pin LQFP . . . . . 641  
 24.6 Package Information for the 196-Ball MAPBGA . . . . . 642  
 24.7 144-Pin LQFP Mechanical Drawing . . . . . 643

24.8	100-Pin LQFP Mechanical Drawing . . . . .	644
24.9	196-Ball MAPBGA Mechanical Drawing . . . . .	645

### **Section 25. Ordering Information**

25.1	Contents . . . . .	647
25.2	Introduction . . . . .	647
25.3	MC Order Numbers . . . . .	647

### **Appendix A. Security**

A.1	Contents . . . . .	649
A.2	Security Philosophy/Strategy . . . . .	649
A.3	MCU Operation with Security Enabled . . . . .	650
A.4	FLASH Access Blocking Mechanisms . . . . .	650
A.4.1	Forced Operating Mode Selection . . . . .	650
A.4.2	Disabled OnCE Access . . . . .	651



## List of Figures

Figure	Title	Page
1-1	Block Diagram . . . . .	52
2-1	MMC2112 Address Map . . . . .	54
2-2	MMC2113 Address Map . . . . .	54
2-3	MMC2114 Address Map . . . . .	55
2-4	Register Summary . . . . .	57
3-1	196-Ball MAPBGA Assignments . . . . .	103
3-2	144-Pin LQFP Assignments . . . . .	104
3-3	100-Pin LQFP Assignments . . . . .	105
4-1	Chip Configuration Module Block Diagram . . . . .	124
4-2	Chip Configuration Register (CCR) . . . . .	126
4-3	Reset Configuration Register (RCON) . . . . .	129
4-4	Chip Identification Register (CIR) . . . . .	131
4-5	Chip Test Register (CTR) . . . . .	132
5-1	Reset Controller Block Diagram . . . . .	141
5-2	Reset Control Register (RCR) . . . . .	143
5-3	Reset Status Register (RSR) . . . . .	145
5-4	Reset Control Flow . . . . .	150
7-1	M•CORE Processor Block Diagram . . . . .	167
7-2	Programming Model . . . . .	169
7-3	Data Organization in Memory . . . . .	171
7-4	Data Organization in Registers . . . . .	171
8-1	Interrupt Controller Block Diagram . . . . .	179
8-2	Interrupt Control Register (ICR) . . . . .	181

Figure	Title	Page
8-3	Interrupt Status Register (ISR) . . . . .	183
8-4	Interrupt Force Register High (IFRH) . . . . .	184
8-5	Interrupt Force Register Low (IFRL) . . . . .	185
8-6	Interrupt Pending Register (IPR) . . . . .	186
8-7	Normal Interrupt Enable Register (NIER) . . . . .	187
8-8	Normal Interrupt Pending Register (NIPR) . . . . .	188
8-9	Fast Interrupt Enable Register (FIER) . . . . .	189
8-10	Fast Interrupt Pending Register (FIPR) . . . . .	190
8-11	Priority Level Select Registers (PLSR0–PLSR39) . . . . .	191
10-1	SGFM Module Block Diagram . . . . .	208
10-2	SGFM Array Memory Map . . . . .	209
10-3	SGFM Module Configuration Register (SGFMCR) . . . . .	213
10-4	SGFM Clock Divider Register (SGFMCLKD) . . . . .	215
10-5	SGFM Test Register (SGFMTST) . . . . .	216
10-6	SGFM Security Register (SGFMSEC) . . . . .	217
10-7	SGFM Monitor Data Register (SGFMMNTR) . . . . .	219
10-8	SGFM Protection Register (SGFMPROT) . . . . .	220
10-9	SGFMPROT Protection Diagram . . . . .	221
10-10	SGFM Supervisor Access Register (SGFMASACC) . . . . .	222
10-11	SGFM Data Access Register (SGFMDACC) . . . . .	223
10-12	SGFM Test Status Register (SGFMTSTAT) . . . . .	224
10-13	SGFM User Status Register (SGFMUSTAT) . . . . .	224
10-14	SGFM Command Register (SGFMCMD) . . . . .	226
10-15	SGFM Control Register (SGFMCTL) . . . . .	227
10-16	SGFM Address Register (SGFMADR) . . . . .	228
10-17	SGFM Data Register (SGFMDATA) . . . . .	229
10-18	Example Program Algorithm . . . . .	235
10-19	SGFM Interrupt Implementation . . . . .	241
11-1	Clock Module Block Diagram . . . . .	247
11-2	Synthesizer Control Register (SYNCR) . . . . .	250
11-3	Synthesizer Status Register (SYNSR) . . . . .	253
11-4	Synthesizer Test Register (SYNTR) . . . . .	256
11-5	Synthesizer Test Register 2 (SYNTR2) . . . . .	257
11-6	Lock Detect Sequence . . . . .	260



Figure	Title	Page
11-7	PLL Block Diagram . . . . .	267
11-8	Crystal Oscillator Example . . . . .	267
12-1	Ports Module Block Diagram . . . . .	272
12-2	Port Output Data Registers (PORTx) . . . . .	275
12-3	Port Data Direction Registers (DDRx) . . . . .	276
12-4	Port Pin Data/Set Data Registers (PORTxP/SETx) . . . . .	277
12-5	Port Clear Output Data Registers (CLRx). . . . .	278
12-6	Port C, D, I7, and I6 Pin Assignment Register (PCDPAR) . . . . .	279
12-7	Port E Pin Assignment Register (PEPAR) . . . . .	280
12-8	Digital Input Timing . . . . .	283
12-9	Digital Output Timing . . . . .	283
13-1	EPORT Block Diagram . . . . .	286
13-2	EPORT Pin Assignment Register (EPPAR) . . . . .	288
13-3	EPORT Data Direction Register (EPDDR) . . . . .	290
13-4	EPORT Port Interrupt Enable Register (EPIER). . . . .	291
13-5	EPORT Port Data Register (EPDR) . . . . .	292
13-6	EPORT Port Pin Data Register (EPPDR). . . . .	292
13-7	EPORT Port Flag Register (EPFR) . . . . .	293
14-1	Watchdog Timer Block Diagram . . . . .	297
14-2	Watchdog Control Register (WCR). . . . .	299
14-3	Watchdog Modulus Register (WMR) . . . . .	301
14-4	Watchdog Count Register (WCNTR) . . . . .	302
14-5	Watchdog Service Register (WSR) . . . . .	303
15-1	PIT Block Diagram . . . . .	306
15-2	PIT Control and Status Register (PCSR) . . . . .	309
15-3	PIT Modulus Register (PMR) . . . . .	312
15-4	PIT Count Register (PCNTR) . . . . .	313
15-5	Counter Reloading from the Modulus Latch . . . . .	314
15-6	Counter in Free-Running Mode . . . . .	315
16-1	Timer Block Diagram . . . . .	320
16-2	Timer Input Capture/Output Compare Select Register (TIMIOS). . . . .	324

Figure	Title	Page
16-3	Timer Compare Force Register (TIMCFORC) . . . . .	325
16-4	Timer Output Compare 3 Mask Register (TIMOC3M) . . . . .	326
16-5	Timer Output Compare 3 Data Register (TIMOC3D) . . . . .	327
16-6	Timer Counter Register High (TIMCNTH) . . . . .	328
16-7	Timer Counter Register Low (TIMCNTL) . . . . .	328
16-8	Timer System Control Register (TIMSCR1) . . . . .	329
16-9	Fast Clear Flag Logic . . . . .	330
16-10	Timer Toggle-On-Overflow Register (TIMTOV) . . . . .	330
16-11	Timer Control Register 1 (TIMCTL1) . . . . .	331
16-12	Timer Control Register 2 (TIMCTL2) . . . . .	332
16-13	Timer Interrupt Enable Register (TIMIE) . . . . .	333
16-14	Timer System Control Register 2 (TIMSCR2) . . . . .	334
16-15	Timer Flag Register 1 (TIMFLG1) . . . . .	336
16-16	Timer Flag Register 2 (TIMFLG2) . . . . .	337
16-17	Timer Channel [0:3] Register High (TIMCxH) . . . . .	338
16-18	Timer Channel [0:3] Register Low (TIMCxL) . . . . .	338
16-19	Pulse Accumulator Control Register (TIMPACTL) . . . . .	339
16-20	Pulse Accumulator Flag Register (TIMPAFLG) . . . . .	341
16-21	Pulse Accumulator Counter Register High (TIMPACNTH) . . . . .	342
16-22	Pulse Accumulator Counter Register Low (TIMPACNTL) . . . . .	342
16-23	Timer Port Data Register (TIMPORT) . . . . .	343
16-24	Timer Port Data Direction Register (TIMDDR) . . . . .	344
16-25	Timer Test Register (TIMTST) . . . . .	345
16-26	Channel 3 Output Compare/Pulse Accumulator Logic . . . . .	348
17-1	SCI Block Diagram . . . . .	356
17-2	SCI Baud Rate Register High (SCIBDH) . . . . .	360
17-3	SCI Baud Rate Register Low (SCIBDL) . . . . .	360
17-4	SCI Control Register 1 (SCICR1) . . . . .	361
17-5	SCI Control Register 2 (SCICR2) . . . . .	364
17-6	SCI Status Register 1 (SCISR1) . . . . .	366
17-7	SCI Status Register 2 (SCISR2) . . . . .	369
17-8	SCI Data Register High (SCIDRH) . . . . .	370
17-9	SCI Data Register Low (SCIDRL) . . . . .	370

Figure	Title	Page
17-10	SCI Pullup and Reduced Drive Register (SCIPURD)	371
17-11	SCI Port Data Register (SCIPOINT)	372
17-12	SCI Data Direction Register (SCIDDR)	373
17-13	SCI Data Formats	374
17-14	Transmitter Block Diagram	376
17-15	SCI Receiver Block Diagram	381
17-16	Receiver Data Sampling	382
17-17	Start Bit Search Example 1	384
17-18	Start Bit Search Example 2	385
17-19	Start Bit Search Example 3	385
17-20	Start Bit Search Example 4	386
17-21	Start Bit Search Example 5	386
17-22	Start Bit Search Example 6	387
17-23	Slow Data	388
17-24	Fast Data	389
17-25	Single-Wire Operation (LOOPS = 1, RSRC = 1)	392
17-26	Loop Operation (LOOPS = 1, RSRC = 0)	393
18-1	SPI Block Diagram	399
18-2	SPI Control Register 1 (SPICR1)	402
18-3	SPI Control Register 2 (SPICR2)	405
18-4	SPI Baud Rate Register (SPIBR)	406
18-5	SPI Status Register (SPISR)	408
18-6	SPI Data Register (SPIDR)	409
18-7	SPI Pullup and Reduced Drive Register (SPIPURD)	410
18-8	SPI Port Data Register (SPIPOINT)	411
18-9	SPI Port Data Direction Register (SPIDDR)	412
18-10	Full-Duplex Operation	413
18-11	SPI Clock Format 1 (CPHA = 1)	417
18-12	SPI Clock Format 0 (CPHA = 0)	418
18-13	Transmission Error Due to Master/Slave Clock Skew	419
19-1	QADC Block Diagram	429
19-2	QADC Input and Output Signals	432
19-3	QADC Module Configuration Register (QADCMCR)	437
19-4	QADC Test Register (QADCTEST)	438

**List of Figures**

Figure	Title	Page
19-5	QADC Port QA Data Register (PORTQA) .....	439
19-6	QADC Port QB Data Register (PORTQB) .....	439
19-7	QADC Port QA Data Direction Register (DDRQA) and Port QB Data Direction Register (DDRQB) .....	441
19-8	QADC Control Register 0 (QACR0) .....	442
19-9	QADC Control Register 1 (QACR1) .....	445
19-10	QADC Control Register 2 (QACR2) .....	448
19-11	QADC Status Register 0 (QASR0) .....	453
19-12	Queue Status Transition .....	461
19-13	QADC Status Register 1 (QASR1) .....	462
19-14	Conversion Command Word Table (CCW) .....	464
19-15	Right-Justified Unsigned Result Register (RJURR) .....	468
19-16	Left-Justified Signed Result Register (LJSRR) .....	469
19-17	Left-Justified Unsigned Result Register (LJURR) .....	470
19-18	External Multiplexing Configuration .....	472
19-19	QADC Analog Subsystem Block Diagram .....	474
19-20	Conversion Timing .....	475
19-21	Bypass Mode Conversion Timing .....	476
19-22	QADC Queue Operation with Pause .....	480
19-23	CCW Priority Situation 1 .....	483
19-24	CCW Priority Situation 2 .....	483
19-25	CCW Priority Situation 3 .....	484
19-26	CCW Priority Situation 4 .....	484
19-27	CCW Priority Situation 5 .....	485
19-28	CCW Priority Situation 6 .....	486
19-29	CCW Priority Situation 7 .....	486
19-30	CCW Priority Situation 8 .....	487
19-31	CCW Priority Situation 9 .....	487
19-32	CCW Priority Situation 10 .....	488
19-33	CCW Priority Situation 11 .....	488
19-34	CCW Freeze Situation 12 .....	489
19-35	CCW Freeze Situation 13 .....	489
19-36	CCW Freeze Situation 14 .....	490
19-37	CCW Freeze Situation 15 .....	490
19-38	CCW Freeze Situation 16 .....	490
19-39	CCW Freeze Situation 17 .....	491

Figure	Title	Page
19-40	CCW Freeze Situation 18 . . . . .	491
19-41	CCW Freeze Situation 19 . . . . .	491
19-42	QADC Clock Subsystem Functions . . . . .	503
19-43	QADC Conversion Queue Operation . . . . .	506
19-44	Equivalent Analog Input Circuitry . . . . .	510
19-45	Errors Resulting from Clipping . . . . .	511
19-46	External Positive Edge Trigger Mode Timing with Pause . . . . .	512
19-47	Gated Mode, Single Scan Timing . . . . .	514
19-48	Gated Mode, Continuous Scan Timing . . . . .	514
19-49	Star-Ground at the Point of Power Supply Origin . . . . .	516
19-50	Input Pin Subjected to Negative Stress . . . . .	518
19-51	Input Pin Subjected to Positive Stress . . . . .	518
19-52	External Multiplexing of Analog Signal Sources . . . . .	520
19-53	Electrical Model of an A/D Input Pin . . . . .	521
20-1	Read Cycle Flowchart . . . . .	535
20-2	Write Cycle Flowchart . . . . .	537
20-3	Master Mode — 1-Clock Read and Write Cycle . . . . .	539
20-4	Master Mode — 2-Clock Read and Write Cycle . . . . .	539
20-5	Internal (Show) Cycle Followed by External 1-Clock Read . . . . .	542
20-6	Internal (Show) Cycle Followed by External 1-Clock Write . . . . .	543
21-1	Chip Select Block Diagram . . . . .	549
21-2	Chip Select Control Register 0 (CSCR0) . . . . .	551
21-3	Chip Select Control Register 1 (CSCR1) . . . . .	552
21-4	Chip Select Control Register 2 (CSCR2) . . . . .	552
21-5	Chip Select Control Register 3 (CSCR3) . . . . .	553
22-1	Top-Level Tap Module and Low-Level (OnCE) TAP Module . . . . .	562
22-2	Top-Level TAP Controller State Machine . . . . .	566
22-3	IDCODE Register Bit Specification . . . . .	571
22-4	OnCE Block Diagram . . . . .	579
22-5	Low-Level (OnCE) Tap Module Data Registers (DRs) . . . . .	580
22-6	OnCE Controller . . . . .	583
22-7	OnCE Controller and Serial Interface . . . . .	585

Figure	Title	Page
22-8	OnCE Interface Diagram . . . . .	586
22-9	OnCE Command Register (OCMR) . . . . .	588
22-10	OnCE Control Register (OCR) . . . . .	590
22-11	OnCE Status Register (OSR) . . . . .	594
22-12	OnCE Memory Breakpoint Logic . . . . .	596
22-13	OnCE Trace Logic Block Diagram . . . . .	599
22-14	CPU Scan Chain Register (CPUSCR) . . . . .	602
22-15	Control State Register (CTL) . . . . .	604
22-16	OnCE PC FIFO . . . . .	606
22-17	Recommended Connector Interface to JTAG/OnCE Port . . . . .	609
23-1	CLKOUT Timing . . . . .	626
23-2	Clock Read/Write Cycle Timing . . . . .	627
23-3	Read/Write Cycle Timing with Wait States . . . . .	628
23-4	Show Cycle Timing . . . . .	629
23-5	GPIO Timing . . . . .	630
23-6	RESET and Configuration Override Timing . . . . .	631
23-7	SPI Timing Diagram . . . . .	633
23-8	Test Clock Input Timing . . . . .	635
23-9	Boundary Scan (JTAG) Timing . . . . .	636
23-10	Test Access Port Timing . . . . .	636
23-11	TRST Timing . . . . .	636
23-12	Debug Event Pin Timing . . . . .	637

## List of Tables

Table	Title	Page
1-1	Package Option Summary . . . . .	46
2-1	Register Address Location Map . . . . .	56
3-1	Package Pinouts. . . . .	98
3-2	Signal Descriptions. . . . .	106
4-1	Signal Properties . . . . .	124
4-2	Write-Once Bits Read/Write Accessibility. . . . .	125
4-3	Chip Configuration Module Memory Map. . . . .	126
4-4	Chip Configuration Mode Selection . . . . .	127
4-5	Bus Monitor Timeout Values. . . . .	129
4-6	Reset Configuration Pin States During Reset. . . . .	133
4-7	Configuration During Reset . . . . .	134
4-8	Chip Configuration Mode Selection . . . . .	135
4-9	Chip Select CS0 Configuration Encoding. . . . .	136
4-10	Boot Device Selection. . . . .	136
4-11	Output Pad Driver Strength Selection. . . . .	137
4-12	Clock Mode Selection. . . . .	137
5-1	Reset Controller Signal Properties . . . . .	141
5-2	Reset Controller Address Map . . . . .	142
5-3	Reset Source Summary . . . . .	147
6-1	CPU and Peripherals in Low-Power Modes . . . . .	164
7-1	M•CORE Instruction Set . . . . .	173

Table	Title	Page
8-1	Interrupt Controller Module Memory Map . . . . .	180
8-2	MASK Encoding . . . . .	182
8-3	Priority Select Encoding . . . . .	191
8-4	Fast Interrupt Vector Number . . . . .	194
8-5	Vector Table Mapping . . . . .	194
8-6	Interrupt Source Assignment . . . . .	197
10-1	SGFM Configuration Field . . . . .	211
10-2	SGFM Register Address Map . . . . .	212
10-3	Register Bank Select Decoding . . . . .	215
10-4	Security States . . . . .	218
10-5	SGFMCMD User Mode Commands . . . . .	226
10-6	FLASH User Mode Commands . . . . .	234
10-7	SGFM Interrupt Sources . . . . .	240
11-1	Signal Properties . . . . .	248
11-2	Clock Module Memory Map . . . . .	249
11-3	System Frequency Multiplier of the Reference Frequency in Normal PLL Mode . . . . .	251
11-4	STPMD[1:0] Operation in Stop Mode . . . . .	253
11-5	System Clock Modes . . . . .	254
11-6	Clock-Out and Clock-In Relationships . . . . .	258
11-7	Loss of Clock Summary . . . . .	262
11-8	Stop Mode Operation . . . . .	263
11-9	Charge Pump Current and MFD in Normal Mode Operation . . . . .	268
12-1	I/O Port Module Memory Map . . . . .	274
12-2	PEPAR Reset Values . . . . .	280
12-3	Ports A–I Supported Pin Functions . . . . .	282
13-1	Edge Port Module Memory Map . . . . .	287
13-2	EPPAx Field Settings . . . . .	289
14-1	Watchdog Timer Module Memory Map . . . . .	298



Table	Title	Page
15-1	Programmable Interrupt Timer Modules Memory Map . . . . .	308
15-2	Prescaler Select Encoding . . . . .	310
15-3	PIT Interrupt Requests . . . . .	316
16-1	Signal Properties . . . . .	322
16-2	Timer Modules Memory Map . . . . .	323
16-3	Output Compare Action Selection . . . . .	331
16-4	Input Capture Edge Selection. . . . .	332
16-5	Prescaler Selection. . . . .	335
16-6	Clock Selection. . . . .	340
16-7	Timer Settings and Pin Functions. . . . .	350
16-8	Timer Interrupt Requests . . . . .	351
17-1	Signal Properties . . . . .	358
17-2	Serial Communications Interface Module Memory Map . . . . .	359
17-3	SCI Normal, Loop, and Single-Wire Mode Pin Configurations . . . . .	362
17-4	Example Baud Rates (System Clock = 33 MHz) . . . . .	375
17-5	Example 10-Bit and 11-Bit Frames. . . . .	377
17-6	Start Bit Verification . . . . .	383
17-7	Data Bit Recovery. . . . .	383
17-8	Stop Bit Recovery. . . . .	384
17-9	SCI Port Control Summary . . . . .	394
17-10	SCI Interrupt Request Sources. . . . .	395
18-1	Signal Properties . . . . .	400
18-2	SPI Memory Map . . . . .	402
18-3	SS Pin I/O Configurations. . . . .	404
18-4	Bidirectional Pin Configurations . . . . .	405
18-5	SPI Baud Rate Selection (33-MHz Module Clock) . . . . .	407
18-6	SPI Port Summary . . . . .	411
18-7	Normal Mode and Bidirectional Mode. . . . .	421
18-8	SPI Interrupt Request Sources. . . . .	424
19-1	Multiplexed Analog Input Channels . . . . .	435
19-2	QADC Memory Map . . . . .	436

Table	Title	Page
19-3	Prescaler $f_{SYS}$ Divide-by Values . . . . .	444
19-4	Queue 1 Operating Modes . . . . .	446
19-5	Queue 2 Operating Modes . . . . .	449
19-6	CCW Pause Bit Response . . . . .	455
19-7	Queue Status . . . . .	458
19-8	Input Sample Times . . . . .	465
19-9	Non-Multiplexed Channel Assignments and Pin Designations . . . . .	466
19-10	Multiplexed Channel Assignments and Pin Designations . . . . .	467
19-11	Analog Input Channels . . . . .	473
19-12	Trigger Events . . . . .	481
19-13	Status Bits . . . . .	482
19-14	External Circuit Settling Time to 1/2 LSB . . . . .	523
19-15	Error Resulting from Input Leakage ( $I_{Off}$ ) . . . . .	524
19-16	QADC Status Flags and Interrupt Sources . . . . .	524
20-1	Signal Properties . . . . .	529
20-2	Data Transfer Cases . . . . .	533
20-3	<u>EB[3:0]</u> Assertion Encoding . . . . .	534
20-4	Emulation Mode Chip-Select Summary . . . . .	541
20-5	Transfer Code Definitions . . . . .	544
20-6	Processor Status Encoding . . . . .	544
21-1	Signal Properties . . . . .	550
21-2	Chip Select Memory Map . . . . .	550
21-3	Chip Select Wait States Encoding . . . . .	555
21-4	Chip Select Address Range Encoding . . . . .	557
22-1	JTAG Instructions . . . . .	568
22-2	List of Pins Not Scanned in JTAG Mode . . . . .	574
22-3	Boundary Scan Register Definition . . . . .	575
22-4	OnCE Register Addressing . . . . .	589
22-5	Sequential Control Field Settings . . . . .	591
22-6	Memory Breakpoint Control Field Settings . . . . .	593
22-7	Processor Mode Field Settings . . . . .	595

Table	Title	Page
23-1	Absolute Maximum Ratings . . . . .	613
23-2	Thermal Characteristics . . . . .	614
23-3	ESD Protection Characteristics . . . . .	615
23-4	DC Electrical Specifications . . . . .	616
23-5	PLL Electrical Specifications. . . . .	618
23-6	QADC Absolute Maximum Ratings. . . . .	620
23-7	QADC Electrical Specifications (Operating) . . . . .	621
23-8	QADC Conversion Specifications (Operating) . . . . .	622
23-9	SGFM FLASH Program and Erase Characteristics . . . . .	624
23-10	SGFM FLASH Module Life Characteristics . . . . .	624
23-11	External Interface Timing Characteristics . . . . .	625
23-12	GPIO Timing . . . . .	630
23-13	Reset and Configuration Override Timing . . . . .	631
23-14	SPI Timing Characteristics . . . . .	632
23-15	OnCE, JTAG, and Boundary Scan Timing . . . . .	635
25-1	MC Order Numbers . . . . .	647



## Section 1. General Description

### 1.1 Contents

1.2	Introduction .....	45
1.3	Features .....	46
1.4	Block Diagram .....	51

### 1.2 Introduction

The MMC2114, MMC2113, and MMC2112 are members of a family of general-purpose microcontrollers (MCU) based on the M•CORE M210 central processor unit (CPU).

These are low-voltage devices that operate between 2.7 volts and 3.6 volts. They are well suited for use in battery-powered applications. The maximum operating frequency is 33 MHz over a temperature range of  $-40^{\circ}\text{C}$  to  $85^{\circ}\text{C}$ .

Available packages are:

- 100-pin low-profile quad flat pack (LQFP) for single-chip mode operation
- 144-pin LQFP for applications requiring an external memory interface or a large number of general-purpose inputs/outputs (GPIO)
- 196-ball plastic mold array process ball grid array (MAPBGA) providing the same functionality as the 144-pin LQFP in a smaller form factor

**Table 1-1** summarizes the memory sizes, package options, and operating modes of the MMC2112, MMC2113, and MMC2114.

**Table 1-1. Package Option Summary**

Device	On-Chip SRAM (Kbytes)	On-Chip FLASH (Kbytes)	Packages	Operating Modes <sup>(1)</sup>
MMC2112	32	—	144 LQFP 196 MAPBGA	Master only
MMC2113	8	128	100 LQFP 144 LQFP 196 MAPBGA	Single chip Master Emulation
MMC2114	32	256		

1. See [4.4 Modes of Operation](#) for descriptions of the different MCU operating modes.

**NOTE:** *The MMC2113 may contain more than 8K of internal SRAM, but only the 8K range from 0x0080\_0000 to 0x0080\_1fff is tested and guaranteed to be operational. It is recommended that internal SRAM outside this range not be used. Accesses to SRAM outside this range terminate without a transfer error exception.*

### 1.3 Features

Features include:

- M•CORE M210 integer processor:
  - 32-bit reduced instruction set computer (RISC) architecture
  - Low power and high performance
- OnCE debug support
- 128 Kbytes (MMC2113) or 256 Kbytes (MMC2114) FLASH memory<sup>(1)</sup>:
  - Single cycle byte, half-word (16-bit) and word (32-bit) reads
  - Fast automated program and erase cycles
  - Ability to program one FLASH bank while executing from another (MMC2114 only)
  - Interrupt on program/erase command completion
  - Flexible protection scheme for accidental program/erase
  - Access restriction controls for both supervisor/user and data/program spaces

1. The MMC2112 has no integrated FLASH memory and is intended for use with external non-volatile memory devices.

- Enhanced security feature prevents unauthorized access to contents of FLASH (protects company IP)
- Single supply operation (no need for separate, high voltage program/erase supply)
- 8 Kbytes (MMC2113) or 32 Kbytes (MMC2112 and MMC2114) of static random-access memory (SRAM):
  - Single cycle byte, half-word (16-bit), and word (32-bit) reads and writes
  - Standby power supply support
- Serial peripheral interface (SPI):
  - Master mode and slave mode
  - Wired-OR mode
  - Slave select output
  - Mode fault error flag with CPU interrupt capability
  - Double-buffered receiver
  - Serial clock with programmable polarity and phase
  - Control of SPI operation during wait mode
  - Reduced drive control
  - General-purpose input/output (I/O) capability
- Two serial communications interfaces (SCI):
  - Full-duplex operation
  - Standard mark/space non-return-to-zero (NRZ) format
  - 13-bit baud rate prescaler
  - Programmable 8-bit or 9-bit data format
  - Separately enabled transmitter and receiver
  - Separate receiver and transmitter CPU interrupt requests
  - Two receiver wakeup methods (idle line and address mark)
  - Receiver framing error detection
  - Hardware parity checking
  - 1/16 bit-time noise detection
  - Reduced drive control
  - General-purpose I/O capability

- Two timers:
  - Four 16-bit input capture/output compare channels
  - 16-bit architecture
  - 16-bit pulse accumulator
  - Pulse widths variable from microseconds to seconds
  - Eight selectable prescalers
  - Toggle-on-overflow feature for pulse-width modulation
- Queued analog-to-digital converter (QADC):
  - Eight analog input channels
  - 10-bit resolution  $\pm 2$  counts accuracy
  - Minimum 7  $\mu$ s conversion time
  - Internal sample and hold
  - Programmable input sample time for various source impedances
  - Two conversion command queues with a total of 64 entries
  - Subqueues possible using pause mechanism
  - Queue complete and pause interrupts available on both queues
  - Queue pointers indicate current location for each queue
  - Automated queue modes initiated by:
    - External edge trigger and gated trigger
    - Periodic/interval timer, within queued analog-to-digital converter (QADC) module {queue1 and queue2}
    - Software command
  - Single-scan or continuous-scan of queues
  - Output data readable in three formats:
    - Right-justified unsigned
    - Left-justified signed
    - Left-justified unsigned
  - Unused analog channels can be used as digital I/O
  - Minimum pin set configuration implemented



- Interrupt controller:
  - Up to 40 interrupt sources
  - 32 unique programmable priority levels for each interrupt source
  - Independent enable/disable of pending interrupts based on priority level
  - Normal or fast interrupt request for each priority level
  - Fast interrupt requests always have priority over normal interrupts
  - Ability to mask interrupts at and below a defined priority level
  - Ability to select between autovectored or vectored interrupt requests
  - Vectored interrupts generated based on priority level
  - Ability to generate a separate vector number for normal and fast interrupts
  - Ability for software to self-schedule interrupts
  - Software visibility of pending interrupts and interrupt signals to core
  - Asynchronous operation to support wakeup from low-power modes
- External interrupts supported:
  - Rising/falling edge select
  - Low-level sensitive
  - Ability for software generation of external interrupt event
  - Interrupt pins configurable as general-purpose I/O
- Two periodic interval timers:
  - 16-bit counter with modulus "initial count" register
  - Selectable as free running or count down
  - 16 selectable prescalers —  $2^0$  to  $2^{15}$
- Watchdog timer:
  - 16-bit counter with modulus "initial count" register
  - Pause option for low-power modes

- Phase-lock loop (PLL):
  - Reference crystal from 2 to 10 MHz
  - Low-power modes supported
  - Separate clock-out signal
- Integrated low-voltage detector (LVD):
  - Can be enabled and disabled under software control
  - Sets flag when  $V_{DD}$  drops below internal bandgap reference threshold
  - Reset and interrupt request enable bits
  - Optional automatic disabling in low-power stop mode
- Reset:
  - Separate reset in and reset out signals
  - Seven sources of reset:
    - Power-on reset (POR)
    - External
    - Software
    - Watchdog timer
    - Loss of clock
    - Loss of PLL lock
    - Low-voltage detect
  - Status flag indicates source of last reset
- Chip configurations:
  - Support for single-chip, master, emulation, and test modes
  - System configuration during reset
  - Bus monitor
  - Configurable output pad drive strength control
- General-purpose input/output (GPIO):
  - Up to 72 bits of GPIO
  - Coherent 32-bit control
  - Bit manipulation supported via set/clear functions
  - Unused peripheral pins may be used as extra GPIO.

- External bus interface:
  - Provides for direct support of asynchronous random-access memory (RAM), read-only memory (ROM), FLASH, and memory mapped peripherals
  - Bidirectional data bus with wide (32-bit) and narrow (16-bit) modes
  - 23-bit address bus with four chip selects provide access to 32 Mbytes of external memory
  - Byte/write enables
  - Boot from on-chip FLASH or external memories
  - Internal bus activity is visible via show-cycle mode
  - Special chip selects support replacement of GPIO with external port replacement logic
- Joint Test Action Group (JTAG) support for system-level board testing

## 1.4 Block Diagram

The basic structure of these devices is shown in [Figure 1-1](#).

General Description

Freescale Semiconductor, Inc.

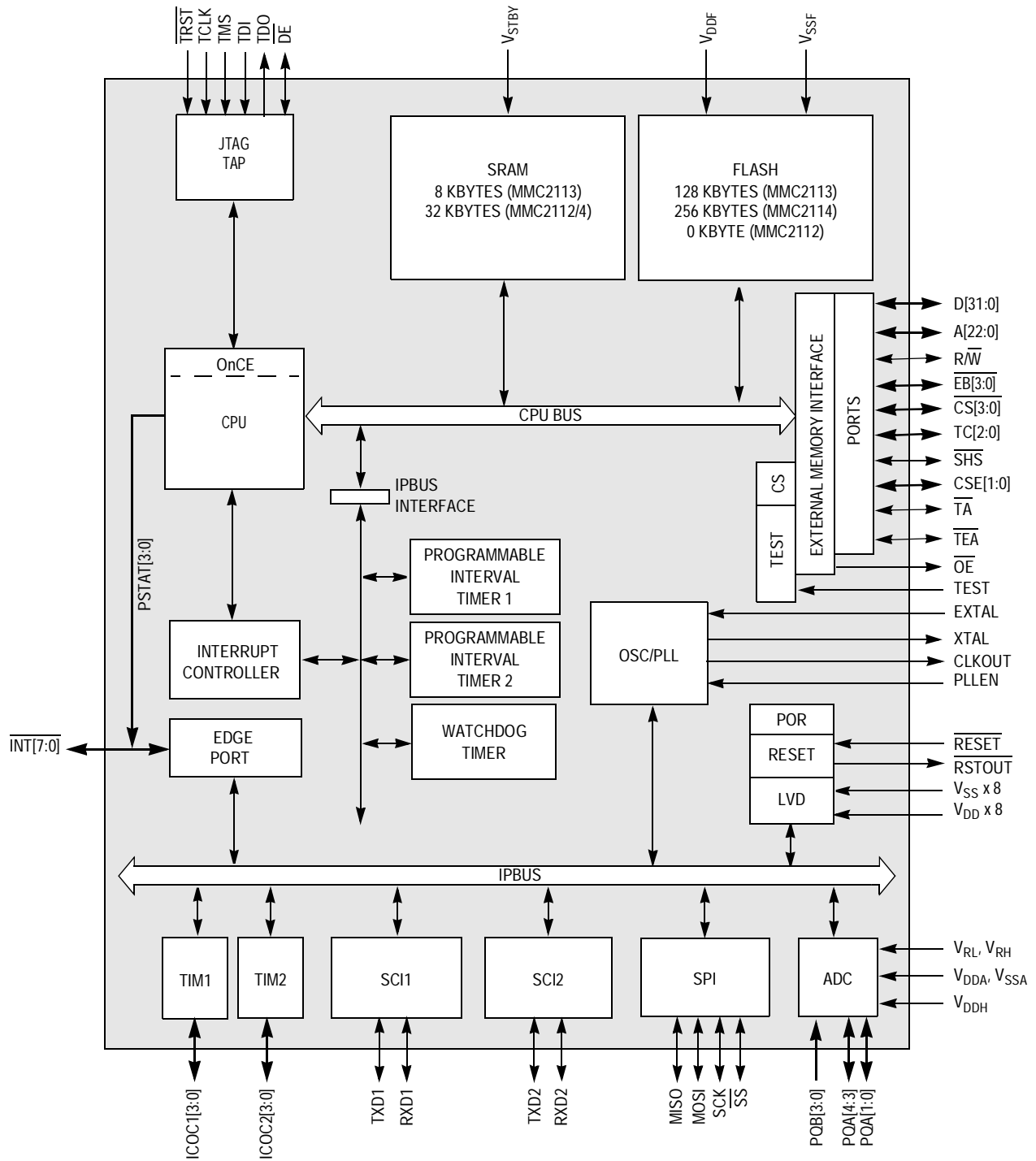

Figure 1-1. Block Diagram

## Section 2. System Memory Map

### 2.1 Contents

2.2	Introduction .....	53
2.3	Address Map .....	54
2.4	Register Map .....	57

### 2.2 Introduction

The address maps, shown in [Figure 2-1](#), [Figure 2-2](#), and [Figure 2-3](#), include:

- Internal FLASH:
  - 256 Kbytes (MMC2114)
  - 128 Kbytes (MMC2113)
  - 0 Kbytes (MMC2112)
- Internal static random-access memory (SRAM):
  - 32 Kbytes (MMC2112 and MMC2114)
  - 8 Kbytes (MMC2113)
- Internal memory mapped registers
- External address space

System Memory Map

2.3 Address Map

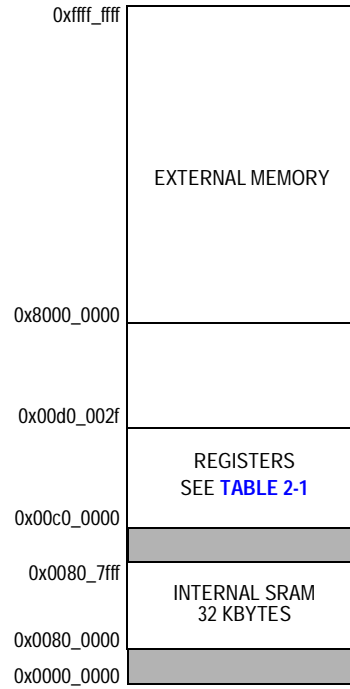

Figure 2-1. MMC2112 Address Map

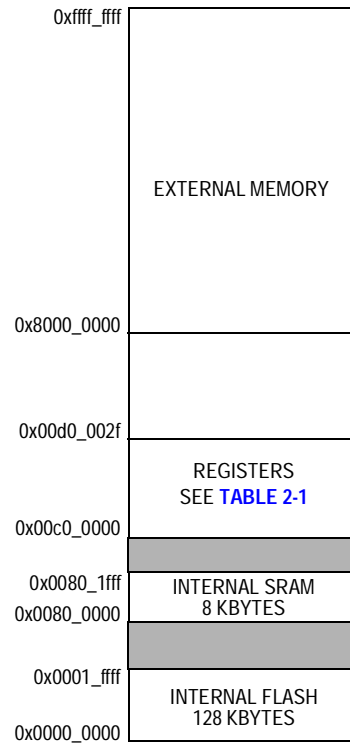
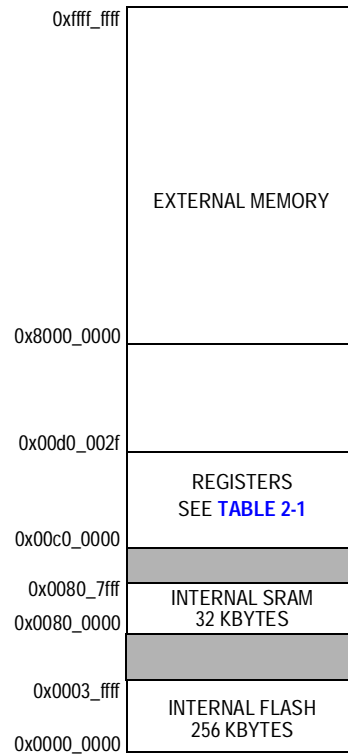

Figure 2-2. MMC2113 Address Map

**NOTE:** The MMC2113 may contain more than 8K of internal SRAM, but only the 8K range from 0x0080\_0000 to 0x0080\_1fff is tested and guaranteed to be operational. It is recommended that internal SRAM outside this range not be used. Accesses to SRAM outside this range terminate without a transfer error exception.



**Figure 2-3. MMC2114 Address Map**

**Table 2-1. Register Address Location Map<sup>(1)</sup>**

Base Address (Hex)	Maximum Size	Usage
0x00c0_0000	64 Kbyte	Ports <sup>(2)</sup> (PORTS)
0x00c1_0000	64 Kbyte	Chip configuration (CCM)
0x00c2_0000	64 Kbyte	Chip selects (CS)
0x00c3_0000	64 Kbyte	Clocks (CLOCK)
0x00c4_0000	64 Kbyte	Reset (RESET)
0x00c5_0000	64 Kbyte	Interrupt controller (INTC)
0x00c6_0000	64 Kbyte	Edge port (EPORT)
0x00c7_0000	64 Kbyte	Watchdog timer (WDT)
0x00c8_0000	64 Kbyte	Programmable interrupt timer 1 (PIT1)
0x00c9_0000	64 Kbyte	Programmable interrupt timer 2 (PIT2)
0x00ca_0000	64 Kbyte	Queued analog-to-digital converter (QADC)
0x00cb_0000	64 Kbyte	Serial peripheral interface (SPI)
0x00cc_0000	64 Kbyte	Serial communications interface 1 (SCI1)
0x00cd_0000	64 Kbyte	Serial communications interface 2 (SCI2)
0x00ce_0000	64 Kbyte	Timer 1 (TIM1)
0x00cf_0000	64 Kbyte	Timer 2 (TIM2)
0x00d0_0000	64 Kbyte	FLASH registers (SGFM)
0x8000_0000	2 Gbyte	External Memory

1. See module sections for details of how much of each block is being decoded. Accesses to addresses outside the module memory maps (and also the reserved area 0x00d1\_0000–0x7fff\_ffff) will not be responded to and will result in a bus monitor transfer error exception.
2. The port register space is mirrored/repeated in the 64-Kbyte block. This allows the full 64-Kbyte block to be decoded and used to execute an external access to a port replacement unit in emulation mode.



## 2.4 Register Map

Address	Register Name	Bit Number									
<b>Ports (PORTS)</b>											
			Bit 7	6	5	4	3	2	1	Bit 0	
0x00c0_0000	Port A Output Data Register (PORTA) <a href="#">See page 275.</a>	Read:	PORTA7	PORTA6	PORTA5	PORTA4	PORTA3	PORTA2	PORTA1	PORTA0	
		Write:									
		Reset:	1	1	1	1	1	1	1	1	1
			Bit 7	6	5	4	3	2	1	Bit 0	
0x00c0_0001	Port B Output Data Register (PORTB) <a href="#">See page 275.</a>	Read:	PORTB7	PORTB6	PORTB5	PORTB4	PORTB3	PORTB2	PORTB1	PORTB0	
		Write:									
		Reset:	1	1	1	1	1	1	1	1	1
			Bit 7	6	5	4	3	2	1	Bit 0	
0x00c0_0002	Port C Output Data Register (PORTC) <a href="#">See page 275.</a>	Read:	PORTC7	PORTC6	PORTC5	PORTC4	PORTC3	PORTC2	PORTC1	PORTC0	
		Write:									
		Reset:	1	1	1	1	1	1	1	1	1
			Bit 7	6	5	4	3	2	1	Bit 0	
0x00c0_0003	Port D Output Data Register (PORTD) <a href="#">See page 275.</a>	Read:	PORTD7	PORTD6	PORTD5	PORTD4	PORTD3	PORTD2	PORTD1	PORTD0	
		Write:									
		Reset:	1	1	1	1	1	1	1	1	1
			Bit 7	6	5	4	3	2	1	Bit 0	
0x00c0_0004	Port E Output Data Register (PORTE) <a href="#">See page 275.</a>	Read:	PORTE7	PORTE6	PORTE5	PORTE4	PORTE3	PORTE2	PORTE1	PORTE0	
		Write:									
		Reset:	1	1	1	1	1	1	1	1	1
			Bit 7	6	5	4	3	2	1	Bit 0	
0x00c0_0005	Port F Output Data Register (PORTF) <a href="#">See page 275.</a>	Read:	PORTF7	PORTF6	PORTF5	PORTF4	PORTF3	PORTF2	PORTF1	PORTF0	
		Write:									
		Reset:	1	1	1	1	1	1	1	1	1
			Bit 7	6	5	4	3	2	1	Bit 0	
0x00c0_0006	Port G Output Data Register (PORTG) <a href="#">See page 275.</a>	Read:	PORTG7	PORTG6	PORTG5	PORTG4	PORTG3	PORTG2	PORTG1	PORTG0	
		Write:									
		Reset:	1	1	1	1	1	1	1	1	1

P = Current pin state

U = Unaffected



= Writes have no effect and the access terminates without a transfer error exception.

**Figure 2-4. Register Summary (Sheet 1 of 37)**

System Memory Map

Address	Register Name	Bit Number								
		Bit 7	6	5	4	3	2	1	Bit 0	
0x00c0_0007	Port H Output Data Register (PORTH) <a href="#">See page 275.</a>	Read:	PORTH7	PORTH6	PORTH5	PORTH4	PORTH3	PORTH2	PORTH1	PORTH0
		Write:								
		Reset:	1	1	1	1	1	1	1	1
0x00c0_0008	Port I Output Data Register (PORTI) <a href="#">See page 275.</a>	Read:	PORTI7	PORTI6	PORTI5	PORTI4	PORTI3	PORTI2	PORTI1	PORTI0
		Write:								
		Reset:	1	1	1	1	1	1	1	1
0x00c0_0009 ↓ 0x00c0_000b	Reserved	Writes have no effect, reads return 0s, and the access terminates without a transfer error exception.								
0x00c0_000c	Port A Data Direction Register (DDRA) <a href="#">See page 276.</a>	Read:	DDRA7	DDRA6	DDRA5	DDRA4	DDRA3	DDRA2	DDRA1	DDRA0
		Write:								
		Reset:	0	0	0	0	0	0	0	0
0x00c0_000d	Port B Data Direction Register (DDRB) <a href="#">See page 276.</a>	Read:	DDRB7	DDRB6	DDRB5	DDRB4	DDRB3	DDRB2	DDRB1	DDRB0
		Write:								
		Reset:	0	0	0	0	0	0	0	0
0x00c0_000e	Port C Data Direction Register (DDRC) <a href="#">See page 276.</a>	Read:	DDRC7	DDRC6	DDRC5	DDRC4	DDRC3	DDRC2	DDRC1	DDRC0
		Write:								
		Reset:	0	0	0	0	0	0	0	0
0x00c0_000f	Port D Data Direction Register (DDRD) <a href="#">See page 276.</a>	Read:	DDRD7	DDRD6	DDRD5	DDRD4	DDRD3	DDRD2	DDRD1	DDRD0
		Write:								
		Reset:	0	0	0	0	0	0	0	0
0x00c0_0010	Port E Data Direction Register (DDRE) <a href="#">See page 276.</a>	Read:	DDRE7	DDRE6	DDRE5	DDRE4	DDRE3	DDRE2	DDRE1	DDRE0
		Write:								
		Reset:	0	0	0	0	0	0	0	0

P = Current pin state    U = Unaffected



= Writes have no effect and the access terminates without a transfer error exception.

Figure 2-4. Register Summary (Sheet 2 of 37)

Address	Register Name	Bit Number								
		Bit 7	6	5	4	3	2	1	Bit 0	
0x00c0_0011	Port F Data Direction Register (DDRF) <a href="#">See page 276.</a>	Read:	DDRF7	DDRF6	DDRF5	DDRF4	DDRF3	DDRF2	DDRF1	DDRF0
		Write:								
		Reset:	0	0	0	0	0	0	0	0
0x00c0_0012	Port G Data Direction Register (DDRG) <a href="#">See page 276.</a>	Read:	DDRG7	DDRG6	DDRG5	DDRG4	DDRG3	DDRG2	DDRG1	DDRG0
		Write:								
		Reset:	0	0	0	0	0	0	0	0
0x00c0_0013	Port H Data Direction Register (DDRH) <a href="#">See page 276.</a>	Read:	DDRH7	DDRH6	DDRH5	DDRH4	DDRH3	DDRH2	DDRH1	DDRH0
		Write:								
		Reset:	0	0	0	0	0	0	0	0
0x00c0_0014	Port I Data Direction Register (DDRI) <a href="#">See page 276.</a>	Read:	DDRI7	DDRI6	DDRI5	DDRI4	DDRI3	DDRI2	DDRI1	DDRI0
		Write:								
		Reset:	0	0	0	0	0	0	0	0
0x00c0_0015 ↓ 0x00c0_0017	Reserved	Writes have no effect, reads return 0s, and the access terminates without a transfer error exception.								
0x00c0_0018	Port A Pin Data/Set Data Register (PORTAP/SETA) <a href="#">See page 277.</a>	Read:	PORTAP7	PORTAP6	PORTAP5	PORTAP4	PORTAP3	PORTAP2	PORTAP1	PORTAP0
		Write:	SETA7	SETA6	SETA5	SETA4	SETA3	SETA2	SETA1	SETA0
		Reset:	P	P	P	P	P	P	P	P
0x00c0_0019	Port B Pin Data/Set Data Register (PORTBP/SETB) <a href="#">See page 277.</a>	Read:	PORTBP7	PORTBP6	PORTBP5	PORTBP4	PORTBP3	PORTBP2	PORTBP1	PORTBP0
		Write:	SETB7	SETB6	SETB5	SETB4	SETB3	SETB2	SETB1	SETB0
		Reset:	P	P	P	P	P	P	P	P
0x00c0_001a	Port C Pin Data/Set Data Register (PORTCP/SETC) <a href="#">See page 277.</a>	Read:	PORTCP7	PORTCP6	PORTCP5	PORTCP4	PORTCP3	PORTCP2	PORTCP1	PORTCP0
		Write:	SETC7	SETC6	SETC5	SETC4	SETC3	SETC2	SETC1	SETC0
		Reset:	P	P	P	P	P	P	P	P

P = Current pin state    U = Unaffected     = Writes have no effect and the access terminates without a transfer error exception.

**Figure 2-4. Register Summary (Sheet 3 of 37)**

System Memory Map

Address	Register Name	Bit Number								
		Bit 7	6	5	4	3	2	1	Bit 0	
0x00c0_001b	Port D Pin Data/Set Data Register (PORTDP/SETD) <a href="#">See page 277.</a>	Read:	PORTDP7	PORTDP6	PORTDP5	PORTDP4	PORTDP3	PORTDP2	PORTDP1	PORTDP0
		Write:	SETD7	SETD6	SETD5	SETD4	SETD3	SETD2	SETD1	SETD0
		Reset:	P	P	P	P	P	P	P	P
0x00c0_001c	Port E Pin Data/Set Data Register (PORTEP/SETE) <a href="#">See page 277.</a>	Read:	PORTEP7	PORTEP6	PORTEP5	PORTEP4	PORTEP3	PORTEP2	PORTEP1	PORTEP0
		Write:	SETE7	SETE6	SETE5	SETE4	SETE3	SETE2	SETE1	SETE0
		Reset:	P	P	P	P	P	P	P	P
0x00c0_001d	Port F Pin Data/Set Data Register (PORTFP/SETF) <a href="#">See page 277.</a>	Read:	PORTFP7	PORTFP6	PORTFP5	PORTFP4	PORTFP3	PORTFP2	PORTFP1	PORTFP0
		Write:	SETF7	SETF6	SETF5	SETF4	SETF3	SETF2	SETF1	SETF0
		Reset:	P	P	P	P	P	P	P	P
0x00c0_001e	Port G Pin Data/Set Data Register (PORTGP/SETG) <a href="#">See page 277.</a>	Read:	PORTGP7	PORTGP6	PORTGP5	PORTGP4	PORTGP3	PORTGP2	PORTGP1	PORTGP0
		Write:	SETG7	SETG6	SETG5	SETG4	SETG3	SETG2	SETG1	SETG0
		Reset:	P	P	P	P	P	P	P	P
0x00c0_001f	Port H Pin Data/Set Data Register (PORTHP/SETH) <a href="#">See page 277.</a>	Read:	PORTHP7	PORTHP6	PORTHP5	PORTHP4	PORTHP3	PORTHP2	PORTHP1	PORTHP0
		Write:	SETH7	SETH6	SETH5	SETH4	SETH3	SETH2	SETH1	SETH0
		Reset:	P	P	P	P	P	P	P	P
0x00c0_0020	Port I Pin Data/Set Data Register (PORTIP/SETI) <a href="#">See page 277.</a>	Read:	PORTIP7	PORTIP6	PORTIP5	PORTIP4	PORTIP3	PORTIP2	PORTIP1	PORTIP0
		Write:	SETI7	SETI6	SETI5	SETI4	SETI3	SETI2	SETI1	SETI0
		Reset:	P	P	P	P	P	P	P	P
0x00c0_0021 ↓ 0x00c0_0023	Reserved	Writes have no effect, reads return 0s, and the access terminates without a transfer error exception.								
0x00c0_0024	Port A Clear Output Data Register (CLRA) <a href="#">See page 278.</a>	Read:	0	0	0	0	0	0	0	0
		Write:	CLRA7	CLRA6	CLRA5	CLRA4	CLRA3	CLRA2	CLRA1	CLRA0
		Reset:	0	0	0	0	0	0	0	0

P = Current pin state    U = Unaffected     = Writes have no effect and the access terminates without a transfer error exception.

Figure 2-4. Register Summary (Sheet 4 of 37)

Address	Register Name	Bit Number								
		Bit 7	6	5	4	3	2	1	Bit 0	
0x00c0_0025	Port B Clear Output Data Register (CLRB) <a href="#">See page 278.</a>	Read:	0	0	0	0	0	0	0	0
		Write:	CLRB7	CLRB6	CLRB5	CLRB4	CLRB3	CLRB2	CLRB1	CLRB0
		Reset:	0	0	0	0	0	0	0	0
0x00c0_0026	Port C Clear Output Data Register (CLRC) <a href="#">See page 278.</a>	Read:	0	0	0	0	0	0	0	0
		Write:	CLRC7	CLRC6	CLRC5	CLRC4	CLRC3	CLRC2	CLRC1	CLRC0
		Reset:	0	0	0	0	0	0	0	0
0x00c0_0027	Port D Clear Output Data Register (CLRD) <a href="#">See page 278.</a>	Read:	0	0	0	0	0	0	0	0
		Write:	CLRD7	CLRD6	CLRD5	CLRD4	CLRD3	CLRD2	CLRD1	CLRD0
		Reset:	0	0	0	0	0	0	0	0
0x00c0_0028	Port E Clear Output Data Register (CLRE) <a href="#">See page 278.</a>	Read:	0	0	0	0	0	0	0	0
		Write:	CLRE7	CLRE6	CLRE5	CLRE4	CLRE3	CLRE2	CLRE1	CLRE0
		Reset:	0	0	0	0	0	0	0	0
0x00c0_0029	Port F Clear Output Data Register (CLRF) <a href="#">See page 278.</a>	Read:	0	0	0	0	0	0	0	0
		Write:	CLRF7	CLRF6	CLRF5	CLRF4	CLRF3	CLRF2	CLRF1	CLRF0
		Reset:	0	0	0	0	0	0	0	0
0x00c0_002a	Port G Clear Output Data Register (CLRG) <a href="#">See page 278.</a>	Read:	0	0	0	0	0	0	0	0
		Write:	CLRG7	CLRG6	CLRG5	CLRG4	CLRG3	CLRG2	CLRG1	CLRG0
		Reset:	0	0	0	0	0	0	0	0
0x00c0_002b	Port H Clear Output Data Register (CLRH) <a href="#">See page 278.</a>	Read:	0	0	0	0	0	0	0	0
		Write:	CLRH7	CLRH6	CLRH5	CLRH4	CLRH3	CLRH2	CLRH1	CLRH0
		Reset:	0	0	0	0	0	0	0	0

P = Current pin state    U = Unaffected    = Writes have no effect and the access terminates without a transfer error exception.

**Figure 2-4. Register Summary (Sheet 5 of 37)**

System Memory Map

Address	Register Name	Bit Number								
		Bit 7	6	5	4	3	2	1	Bit 0	
0x00c0_002c	Port I Clear Output Data Register (CLRI) <a href="#">See page 278.</a>	Read:	0	0	0	0	0	0	0	0
		Write:	CLR17	CLR16	CLR15	CLR14	CLR13	CLR12	CLR11	CLR10
		Reset:	0	0	0	0	0	0	0	0
0x00c0_002d ↓ 0x00c0_002f	Reserved	Writes have no effect, reads return 0s, and the access terminates without a transfer error exception.								
0x00c0_0030	Port C/D Pin Assignment Register (PCDPAR) <a href="#">See page 279.</a>	Read:	PCDPA	0	0	0	0	0	0	0
		Write:								
		Reset:	See note	0	0	0	0	0	0	0
Note: Reset state determined during reset configuration. PCDPA = 1 except in single-chip mode or when an external boot device is selected with a 16-bit port size in master mode.										
0x00c0_0031	Port E Pin Assignment Register (PEPAR) <a href="#">See page 280.</a>	Read:	PEPA7	PEPA6	PEPA5	PEPA4	PEPA3	PEPA2	PEPA1	PEPA0
		Write:								
		Reset:	Reset state determined during reset configuration as shown in <a href="#">Table 12-2. PEPAR Reset Values.</a>							
0x00c0_0032 ↓ 0x00c0_003f	Reserved	Writes have no effect, reads return 0s, and the access terminates without a transfer error exception.								
0x00c0_0040 ↓ 0x00c0_ffff	Reserved	Ports register space (block of 0x00c0_0000 through 0x00c0_003f) is mirrored/repeated.								
P = Current pin state    U = Unaffected		= Writes have no effect and the access terminates without a transfer error exception.								

Figure 2-4. Register Summary (Sheet 6 of 37)

Address	Register Name	Bit Number																																
<b>Chip Configuration Module (CCM)</b>																																		
0x00c1_0000 0x00c1_0001	Chip Configuration Register (CCR) <a href="#">See page 126.</a>	<table border="1"> <tr> <td>Bit 15</td><td>14</td><td>13</td><td>12</td><td>11</td><td>10</td><td>9</td><td>Bit 8</td> </tr> <tr> <td>Read: LOAD</td><td>0</td><td>SHEN</td><td>EMINT</td><td>0</td><td>MODE2</td><td>MODE1</td><td>MODE0</td> </tr> <tr> <td>Write:</td><td></td><td></td><td></td><td></td><td></td><td></td><td></td> </tr> <tr> <td>Reset:</td><td>Note 1</td><td>0</td><td>Note 2</td><td>Note 2</td><td>0</td><td>Note 1</td><td>Note 1</td> </tr> </table>	Bit 15	14	13	12	11	10	9	Bit 8	Read: LOAD	0	SHEN	EMINT	0	MODE2	MODE1	MODE0	Write:								Reset:	Note 1	0	Note 2	Note 2	0	Note 1	Note 1
		Bit 15	14	13	12	11	10	9	Bit 8																									
Read: LOAD	0	SHEN	EMINT	0	MODE2	MODE1	MODE0																											
Write:																																		
Reset:	Note 1	0	Note 2	Note 2	0	Note 1	Note 1																											
<table border="1"> <tr> <td>Bit 7</td><td>6</td><td>5</td><td>4</td><td>3</td><td>2</td><td>1</td><td>Bit 0</td> </tr> <tr> <td>Read: 0</td><td>SZEN</td><td>PSTEN</td><td>SHINT</td><td>BME</td><td>BMD</td><td>BMT1</td><td>BMT0</td> </tr> <tr> <td>Write:</td><td></td><td></td><td></td><td></td><td></td><td></td><td></td> </tr> <tr> <td>Reset:</td><td>0</td><td>Note 3</td><td>Note 2</td><td>0</td><td>1</td><td>0</td><td>0</td> </tr> </table> <p>Notes:</p> <ol style="list-style-type: none"> <li>Determined during reset configuration</li> <li>0 for all configurations except emulation mode, 1 for emulation mode</li> <li>0 for all configurations except emulation and master modes, 1 for emulation and master modes</li> </ol>	Bit 7	6	5	4	3	2	1	Bit 0	Read: 0	SZEN	PSTEN	SHINT	BME	BMD	BMT1	BMT0	Write:								Reset:	0	Note 3	Note 2	0	1	0	0		
Bit 7	6	5	4	3	2	1	Bit 0																											
Read: 0	SZEN	PSTEN	SHINT	BME	BMD	BMT1	BMT0																											
Write:																																		
Reset:	0	Note 3	Note 2	0	1	0	0																											
0x00c1_0002	Reserved	<table border="1"> <tr> <td>Bit 7</td><td>6</td><td>5</td><td>4</td><td>3</td><td>2</td><td>1</td><td>Bit 0</td> </tr> <tr> <td colspan="8">Writes have no effect, reads return 0s, and the access terminates without a transfer error exception.</td> </tr> </table>	Bit 7	6	5	4	3	2	1	Bit 0	Writes have no effect, reads return 0s, and the access terminates without a transfer error exception.																							
Bit 7	6	5	4	3	2	1	Bit 0																											
Writes have no effect, reads return 0s, and the access terminates without a transfer error exception.																																		
0x00c1_0003	Reserved	<table border="1"> <tr> <td>Bit 7</td><td>6</td><td>5</td><td>4</td><td>3</td><td>2</td><td>1</td><td>Bit 0</td> </tr> <tr> <td colspan="8">Writes have no effect, reads return 0s, and the access terminates without a transfer error exception.</td> </tr> </table>	Bit 7	6	5	4	3	2	1	Bit 0	Writes have no effect, reads return 0s, and the access terminates without a transfer error exception.																							
Bit 7	6	5	4	3	2	1	Bit 0																											
Writes have no effect, reads return 0s, and the access terminates without a transfer error exception.																																		
0x00c1_0004 0x00c1_0005	Reset Configuration Register (RCON) <a href="#">See page 129.</a>	<table border="1"> <tr> <td>Bit 15</td><td>14</td><td>13</td><td>12</td><td>11</td><td>10</td><td>9</td><td>Bit 8</td> </tr> <tr> <td>Read: 0</td><td>0</td><td>0</td><td>0</td><td>0</td><td>0</td><td>0</td><td>0</td> </tr> <tr> <td>Write:</td><td></td><td></td><td></td><td></td><td></td><td></td><td></td> </tr> <tr> <td>Reset:</td><td>0</td><td>0</td><td>0</td><td>0</td><td>0</td><td>0</td><td>0</td> </tr> </table>	Bit 15	14	13	12	11	10	9	Bit 8	Read: 0	0	0	0	0	0	0	0	Write:								Reset:	0	0	0	0	0	0	0
		Bit 15	14	13	12	11	10	9	Bit 8																									
Read: 0	0	0	0	0	0	0	0																											
Write:																																		
Reset:	0	0	0	0	0	0	0																											
<table border="1"> <tr> <td>Bit 7</td><td>6</td><td>5</td><td>4</td><td>3</td><td>2</td><td>1</td><td>Bit 0</td> </tr> <tr> <td>Read: RPLLSEL</td><td>RPLLREF</td><td>RLOAD</td><td>0</td><td>BOOTPS</td><td>BOOTSEL</td><td>0</td><td>MODE</td> </tr> <tr> <td>Write:</td><td></td><td></td><td></td><td></td><td></td><td></td><td></td> </tr> <tr> <td>Reset:</td><td>1</td><td>1</td><td>0</td><td>0</td><td>1</td><td>0</td><td>0</td> </tr> </table>	Bit 7	6	5	4	3	2	1	Bit 0	Read: RPLLSEL	RPLLREF	RLOAD	0	BOOTPS	BOOTSEL	0	MODE	Write:								Reset:	1	1	0	0	1	0	0		
Bit 7	6	5	4	3	2	1	Bit 0																											
Read: RPLLSEL	RPLLREF	RLOAD	0	BOOTPS	BOOTSEL	0	MODE																											
Write:																																		
Reset:	1	1	0	0	1	0	0																											
<p>P = Current pin state    U = Unaffected     = Writes have no effect and the access terminates without a transfer error exception.</p>																																		

**Figure 2-4. Register Summary (Sheet 7 of 37)**

System Memory Map

Address	Register Name	Bit Number								
		Bit 15	14	13	12	11	10	9	Bit 8	
0x00c1_0006 0x00c1_0007	Chip Identification Register (CIR) <a href="#">See page 131.</a>	Read:	0 PIN7	0 PIN6	0 PIN5	1 PIN4	0 PIN3	1 PIN2	1 PIN1	1 PIN0
		Write:								
	Reset:	0	0	0	1	0	1	1	1	
		Bit 7	6	5	4	3	2	1	Bit 0	
	Read:	0 PRN7	0 PRN6	0 PRN5	0 PRN4	0 PRN3	0 PRN2	0 PRN1	0 PRN0	
	Write:									
	Reset:	0	0	0	0	0	0	0	0	
0x00c1_0008 0x00c1_0009	Chip Test Register (CTR) <a href="#">See page 132.</a>	Read:	0	0	0	0	0	0	0	
		Write:								
	Reset:	0	0	0	0	0	0	0	0	
		Bit 7	6	5	4	3	2	1	Bit 0	
	Read:	0	0	0	0	0	0	0	0	
	Write:									
	Reset:	0	0	0	0	0	0	0	0	
		Bit 7	6	5	4	3	2	1	Bit 0	
0x00c1_000a 0x00c1_000b	Reserved	Writes have no effect, reads return 0s, and the access terminates without a transfer error exception.								
		Bit 7	6	5	4	3	2	1	Bit 0	
0x00c1_000c ↓ 0x00c1_000f	Unimplemented	Access results in the module generating an access termination transfer error.								
		Bit 7	6	5	4	3	2	1	Bit 0	
0x00c1_0010 ↓ 0x00c1_fff	Unimplemented	Access results in a bus monitor timeout generating an access termination transfer error.								
		Bit 7	6	5	4	3	2	1	Bit 0	

P = Current pin state    U = Unaffected     = Writes have no effect and the access terminates without a transfer error exception.

Figure 2-4. Register Summary (Sheet 8 of 37)



Address	Register Name	Bit Number									
<b>Chip Selects (CS)</b>											
0x00c2_0000 0x00c2_0001	Chip Select Control Register 0 (CSCR0) <a href="#">See page 551.</a>		Bit 15	14	13	12	11	10	9	Bit 8	
		Read:		SO	RO	PS	WWS	WE	WS2	WS1	WS0
		Write:									
		Reset:		0	0	See note	1	1	1	1	1
				Bit 7	6	5	4	3	2	1	Bit 0
		Read:		0	0	0	0	0	0	TAEN	CSEN
Write:											
Reset:		0	0	0	0	0	0	1	See note		
Note: Reset state determined during reset configuration.											
0x00c2_0002 0x00c2_0003	Chip Select Control Register 1 (CSCR1) <a href="#">See page 552.</a>		Bit 15	14	13	12	11	10	9	Bit 8	
		Read:		SO	RO	PS	WWS	WE	WS2	WS1	WS0
		Write:									
		Reset:		0	0	1	1	1	1	1	1
				Bit 7	6	5	4	3	2	1	Bit 0
		Read:		0	0	0	0	0	0	TAEN	CSEN
Write:											
Reset:		0	0	0	0	0	0	1	See note		
Note: Reset state determined during reset configuration											
0x00c2_0004 0x00c2_0005	Chip Select Control Register 2 (CSCR2) <a href="#">See page 552.</a>		Bit 15	14	13	12	11	10	9	Bit 8	
		Read:		SO	RO	PS	WWS	WE	WS2	WS1	WS0
		Write:									
		Reset:		0	0	1	1	1	1	1	1
				Bit 7	6	5	4	3	2	1	Bit 0
		Read:		0	0	0	0	0	0	TAEN	CSEN
Write:											
Reset:		0	0	0	0	0	0	1	0		

P = Current pin state    U = Unaffected     = Writes have no effect and the access terminates without a transfer error exception.

**Figure 2-4. Register Summary (Sheet 9 of 37)**

**System Memory Map**

Address	Register Name	Bit Number								
		Bit 15	14	13	12	11	10	9	Bit 8	
0x00c2_0006 0x00c2_0007	Chip Select Control Register 3 (CSCR3) <a href="#">See page 553.</a>	Read:	SO	RO	PS	WWS	WE	WS2	WS1	WS0
		Write:								
		Reset:	0	0	1	1	1	1	1	1
			Bit 7	6	5	4	3	2	1	Bit 0
		Read:	0	0	0	0	0	0	TAEN	CSEN
		Write:								
		Reset:	0	0	0	0	0	0	1	0
0x00c2_0008 ↓ 0x00c2_ffff	Unimplemented	Access results in a bus monitor timeout generating an access termination transfer error.								

**Clocks (CLOCK)**

Address	Register Name	Bit Number								
		Bit 15	14	13	12	11	10	9	Bit 8	
0x00c3_0000 0x00c3_0001	Synthesizer Control Register (SYNCR) <a href="#">See page 250.</a>	Read:	LOLRE	MFD2	MFD1	MFD0	LOCRE	RFD2	RFD1	RFD0
		Write:								
		Reset:	0	0	1	0	0	0	0	1
			Bit 7	6	5	4	3	2	1	Bit 0
		Read:	LOCEN	DISCLK	FWKUP	RSVD4	STMPD1	STMPD0	RSVD1	RSVD0
		Write:								
		Reset:	0	0	0	0	0	0	0	0
			Bit 7	6	5	4	3	2	1	Bit 0
0x00c3_0002	Synthesizer Status Register (SYNSR) <a href="#">See page 253.</a>	Read:	PLLMODE	PLLSEL	PLLREF	LOCKS	LOCK	LOCS	0	0
		Write:								
		Reset:	Note 1	Note 1	Note 1	Note 2	Note 2	0	0	0

Notes:

1. Reset state determined during reset configuration
2. See the LOCKS and LOCK bit descriptions.

P = Current pin state

U = Unaffected



= Writes have no effect and the access terminates without a transfer error exception.

**Figure 2-4. Register Summary (Sheet 10 of 37)**

Address	Register Name	Bit Number								
		Bit 7	6	5	4	3	2	1	Bit 0	
0x00c3_0003	Synthesizer Test Register (SYNTR) <a href="#">See page 256.</a>	Read:	0	0	0	0	0	0	0	0
		Write:								
		Reset:	0	0	0	0	0	0	0	0
0x00c3_0004 0x00c3_0005 0x00c3_0006 0x00c3_0007	Synthesizer Test Register 2 (SYNTR2) <a href="#">See page 257.</a>	Read:	0	0	0	0	0	0	0	0
		Write:								
		Reset:	0	0	0	0	0	0	0	0
		Read:	0	0	0	0	0	0	0	0
		Write:								
		Reset:	0	0	0	0	0	0	0	0
		Read:	0	0	0	0	0	0	0	0
		Write:								
		Reset:	0	0	0	0	0	0	0	0
		Read:	0	0	0	0	0	0	0	0
		Write:						RSVD9	RSVD8	
		Reset:	0	0	0	0	0	0	0	0
		Read:	RSVD7	RSVD6	RSVD5	RSVD4	RSVD3	RSVD2	RSVD2	RSVD0
		Write:								
		Reset:	0	0	0	0	0	0	0	0
0x00c3_0008 ↓ 0x00c3_ffff	Unimplemented	Access results in a bus monitor timeout generating an access termination transfer error.								

**Reset (RESET)**

Address	Register Name	Bit Number								
		Bit 7	6	5	4	3	2	1	Bit 0	
0x00c4_0000	Reset Control Register (RCR) <a href="#">See page 143.</a>	Read:	SOFTTRST	FRC-RSTOUT	0	LVDF	LVDIE	LVDRE	LVDSE	LVDE
		Write:								
		Reset:	0	0	0	See note	0	0	0	0

Note: Reset dependent

P = Current pin state    U = Unaffected



= Writes have no effect and the access terminates without a transfer error exception.

**Figure 2-4. Register Summary (Sheet 11 of 37)**

System Memory Map

Address	Register Name	Bit Number								
		Bit 7	6	5	4	3	2	1	Bit 0	
0x00c4_0001	Reset Status Register (RSR) <a href="#">See page 143.</a>	Read:	0	LVD	SOFT	WDR	POR	EXT	LOC	LOL
		Write:								
		Reset:	0	Reset dependent						
0x00c4_0002	Reset Test Register (RTR)	Read:	0	0	0	0	0	0	0	0
		Write:								
		Reset:	0	0	0	0	0	0	0	0
0x00c4_0003	Reserved	Writes have no effect, reads return 0s, and the access terminates without a transfer error exception.								
0x00c4_0004 ↓ 0x00c4_ffff	Unimplemented	Access results in a bus monitor timeout generating an access termination transfer error.								

Interrupt Controller (INTC)

Address	Register Name	Bit Number								
		Bit 15	14	13	12	11	10	9	Bit 8	
0x00c5_0000 0x00c5_0001	Interrupt Control Register (ICR) <a href="#">See page 181.</a>	Read:	AE	FVE	ME	MFI	0	0	0	0
		Write:								
		Reset:	1	0	0	0	0	0	0	0
		Read:	0	0	0	MASK4	MASK3	MASK2	MASK1	MASK0
		Write:								
		Reset:	0	0	0	0	0	0	0	0
0x00c5_0002 0x00c5_0003	Interrupt Status Register (ISR) <a href="#">See page 183.</a>	Read:	0	0	0	0	0	0	INT	FINT
		Write:								
		Reset:	0	0	0	0	0	0	0	0
		Read:	0	VEC6	VEC5	VEC4	VEC3	VEC2	VEC1	VEC0
		Write:								
		Reset:	0	0	0	0	0	0	0	0

P = Current pin state    U = Unaffected     = Writes have no effect and the access terminates without a transfer error exception.

Figure 2-4. Register Summary (Sheet 12 of 37)

Address	Register Name	Bit Number									
		Bit 31	30	29	28	27	26	25	Bit 24		
0x00c5_0004 0x00c5_0005 0x00c5_0006 0x00c5_0007	Interrupt Force Register High (IFRH) See page 184.	Read:	0	0	0	0	0	0	0	0	
		Write:									
		Reset:	0	0	0	0	0	0	0	0	
			Bit 23	22	21	20	19	18	17	Bit 16	
		Read:	0	0	0	0	0	0	0	0	
		Write:									
		Reset:	0	0	0	0	0	0	0	0	
			Bit 15	14	13	12	11	10	9	Bit 8	
		Read:	0	0	0	0	0	0	0	0	
		Write:									
		Reset:	0	0	0	0	0	0	0	0	
			Bit 7	6	5	4	3	2	1	Bit 0	
		Read:	IF39	IF38	IF37	IF36	IF35	IF34	IF33	IF32	
		Write:									
		Reset:	0	0	0	0	0	0	0	0	
0x00c5_0008 0x00c5_0009 0x00c5_000a 0x00c5_000b	Interrupt Force Register Low (IFRL) See page 185.	Read:	IF31	IF30	IF29	IF28	IF27	IF26	IF25	IF24	
		Write:									
		Reset:	0	0	0	0	0	0	0	0	0
			Bit 23	22	21	20	19	18	17	Bit 16	
		Read:	IF23	IF22	IF21	IF20	IF19	IF18	IF17	IF16	
		Write:									
		Reset:	0	0	0	0	0	0	0	0	
			Bit 15	14	13	12	11	10	9	Bit 8	
		Read:	IF15	IF14	IF13	IF12	IF11	IF10	IF9	IF8	
		Write:									
		Reset:	0	0	0	0	0	0	0	0	
			Bit 7	6	5	4	3	2	1	Bit 0	
		Read:	IF7	IF6	IF5	IF4	IF3	IF2	IF1	IF0	
		Write:									
		Reset:	0	0	0	0	0	0	0	0	

P = Current pin state    U = Unaffected



= Writes have no effect and the access terminates without a transfer error exception.

**Figure 2-4. Register Summary (Sheet 13 of 37)**

System Memory Map

Address	Register Name	Bit Number								
		Bit 31	30	29	28	27	26	25	Bit 24	
0x00c5_000c 0x00c5_000d 0x00c5_000e 0x00c5_000f	Interrupt Pending Register (IPR) <a href="#">See page 186.</a>	Read:	IP31	IP30	IP29	IP28	IP27	IP26	IP25	IP24
		Write:								
		Reset:	0	0	0	0	0	0	0	0
			Bit 23	22	21	20	19	18	17	Bit 16
		Read:	IP23	IP22	IP21	IP20	IP19	IP18	IP17	IP16
		Write:								
		Reset:	0	0	0	0	0	0	0	0
			Bit 15	14	13	12	11	10	9	Bit 8
		Read:	IP15	IP14	IP13	IP12	IP11	IP10	IP9	IP8
		Write:								
		Reset:	0	0	0	0	0	0	0	0
			Bit 7	6	5	4	3	2	1	Bit 0
		Read:	IP7	IP6	IP5	IP4	IP3	IP2	IP1	IP0
		Write:								
		Reset:	0	0	0	0	0	0	0	0
0x00c5_0010 0x00c5_0011 0x00c5_0012 0x00c5_0013	Normal Interrupt Enable Register (NIER) <a href="#">See page 187.</a>	Read:	NIE31	NIE30	NIE29	NIE28	NIE27	NIE26	NIE25	NIE24
		Write:								
		Reset:	0	0	0	0	0	0	0	0
			Bit 23	22	21	20	19	18	17	Bit 16
		Read:	NIE23	NIE22	NIE21	NIE20	NIE19	NIE18	NIE17	NIE16
		Write:								
		Reset:	0	0	0	0	0	0	0	0
			Bit 15	14	13	12	11	10	9	Bit 8
		Read:	NIE15	NIE14	NIE13	NIE12	NIE11	NIE10	NIE9	NIE8
		Write:								
		Reset:	0	0	0	0	0	0	0	0
			Bit 7	6	5	4	3	2	1	Bit 0
		Read:	NIE7	NIE6	NIE5	NIE4	NIE3	NIE2	NIE1	NIE0
		Write:								
		Reset:	0	0	0	0	0	0	0	0

P = Current pin state    U = Unaffected



= Writes have no effect and the access terminates without a transfer error exception.

Figure 2-4. Register Summary (Sheet 14 of 37)

Address	Register Name	Bit Number								
		Bit 31	30	29	28	27	26	25	Bit 24	
0x00c5_0014 0x00c5_0015 0x00c5_0016 0x00c5_0017	Normal Interrupt Pending Register (NIPR) <a href="#">See page 188.</a>	Read:	NIP31	NIP30	NIP29	NIP28	NIP27	NIP26	NIP25	NIP24
		Write:								
		Reset:	0	0	0	0	0	0	0	0
			Bit 23	22	21	20	19	18	17	Bit 16
	Read:	NIP23	NIP22	NIP21	NIP20	NIP19	NIP18	NIP17	NIP16	
	Write:									
	Reset:	0	0	0	0	0	0	0	0	
		Bit 15	14	13	12	11	10	9	Bit 8	
	Read:	NIP15	NIP14	NIP13	NIP12	NIP11	NIP10	NIP9	NIP8	
	Write:									
	Reset:	0	0	0	0	0	0	0	0	
		Bit 7	6	5	4	3	2	1	Bit 0	
	Read:	NIP7	NIP6	NIP5	NIP4	NIP3	NIP2	NIP1	NIP0	
	Write:									
	Reset:	0	0	0	0	0	0	0	0	
0x00c5_0018 0x00c5_0019 0x00c5_001a 0x00c5_001b	Fast Interrupt Enable Register (FIER) <a href="#">See page 189.</a>	Read:	FIE31	FIE30	FIE29	FIE28	FIE27	FIE26	FIE25	FIE24
		Write:								
		Reset:	0	0	0	0	0	0	0	0
			Bit 23	22	21	20	19	18	17	Bit 16
	Read:	FIE23	FIE22	FIE21	FIE20	FIE19	FIE18	FIE17	FIE16	
	Write:									
	Reset:	0	0	0	0	0	0	0	0	
		Bit 15	14	13	12	11	10	9	Bit 8	
	Read:	FIE15	FIE14	FIE13	FIE12	FIE11	FIE10	FIE9	FIE8	
	Write:									
	Reset:	0	0	0	0	0	0	0	0	
		Bit 7	6	5	4	3	2	1	Bit 0	
	Read:	FIE7	FIE6	FIE5	FIE4	FIE3	FIE2	FIE1	FIE0	
	Write:									
	Reset:	0	0	0	0	0	0	0	0	

P = Current pin state    U = Unaffected



= Writes have no effect and the access terminates without a transfer error exception.

**Figure 2-4. Register Summary (Sheet 15 of 37)**

System Memory Map

Freescale Semiconductor, Inc.

Address	Register Name	Bit Number								
		Bit 31	30	29	28	27	26	25	Bit 24	
0x00c5_001c 0x00c5_001d 0x00c5_001e 0x00c5_001f	Fast Interrupt Pending Register (FIPR) <a href="#">See page 190.</a>	Read:	FIP31	FIP30	FIP29	FIP28	FIP27	FIP26	FIP25	FIP24
		Write:								
		Reset:	0	0	0	0	0	0	0	0
			Bit 23	22	21	20	19	18	17	Bit 16
		Read:	FIP23	FIP22	FIP21	FIP20	FIP19	FIP18	FIP17	FIP16
		Write:								
		Reset:	0	0	0	0	0	0	0	0
			Bit 15	14	13	12	11	10	9	Bit 8
		Read:	FIP15	FIP14	FIP13	FIP12	FIP11	FIP10	FIP9	FIP8
		Write:								
		Reset:	0	0	0	0	0	0	0	0
			Bit 7	6	5	4	3	2	1	Bit 0
		Read:	FIP7	FIP6	FIP5	FIP4	FIP3	FIP2	FIP1	FIP0
		Write:								
		Reset:	0	0	0	0	0	0	0	0
			Bit 7	6	5	4	3	2	1	Bit 0
0x00c5_0040 ↓ 0x00c5_0067	Priority Level Select Registers (PLSR39–PLSR0) <a href="#">See page 191.</a>	Read:	0	0	0	PLS4	PLS3	PLS2	PLS1	PLS0
		Write:								
		Reset:	0	0	0	0	0	0	0	0
			Bit 7	6	5	4	3	2	1	Bit 0
0x00c5_0068 ↓ 0x00c5_007f	Unimplemented	Access results in the module generating an access termination transfer error.								
			Bit 7	6	5	4	3	2	1	Bit 0
0x00c5_0080 ↓ 0x00c5_ffff	Unimplemented	Access results in a bus monitor timeout generating an access termination transfer error.								
			Bit 7	6	5	4	3	2	1	Bit 0

P = Current pin state    U = Unaffected     = Writes have no effect and the access terminates without a transfer error exception.

Figure 2-4. Register Summary (Sheet 16 of 37)



Address	Register Name	Bit Number																																								
<b>Edge Port (EPORT)</b>																																										
0x00c6_0000 0x00c6_0001	EPORT Pin Assignment Register (EPPAR) <a href="#">See page 288.</a>	<table border="1"> <tr> <td>Bit 15</td> <td>14</td> <td>13</td> <td>12</td> <td>11</td> <td>10</td> <td>9</td> <td>Bit 8</td> </tr> <tr> <td colspan="2">EPPA7</td> <td colspan="2">EPPA6</td> <td colspan="2">EPPA5</td> <td colspan="2">EPPA4</td> </tr> <tr> <td>0</td> <td>0</td> <td>0</td> <td>0</td> <td>0</td> <td>0</td> <td>0</td> <td>0</td> </tr> <tr> <td>Bit 7</td> <td>6</td> <td>5</td> <td>4</td> <td>3</td> <td>2</td> <td>1</td> <td>Bit 0</td> </tr> </table>	Bit 15	14	13	12	11	10	9	Bit 8	EPPA7		EPPA6		EPPA5		EPPA4		0	0	0	0	0	0	0	0	Bit 7	6	5	4	3	2	1	Bit 0								
		Bit 15	14	13	12	11	10	9	Bit 8																																	
		EPPA7		EPPA6		EPPA5		EPPA4																																		
		0	0	0	0	0	0	0	0																																	
Bit 7	6	5	4	3	2	1	Bit 0																																			
<table border="1"> <tr> <td colspan="2">EPPA3</td> <td colspan="2">EPPA2</td> <td colspan="2">EPPA1</td> <td colspan="2">EPPA0</td> </tr> <tr> <td>0</td> <td>0</td> <td>0</td> <td>0</td> <td>0</td> <td>0</td> <td>0</td> <td>0</td> </tr> <tr> <td>Bit 7</td> <td>6</td> <td>5</td> <td>4</td> <td>3</td> <td>2</td> <td>1</td> <td>Bit 0</td> </tr> </table>	EPPA3		EPPA2		EPPA1		EPPA0		0	0	0	0	0	0	0	0	Bit 7	6	5	4	3	2	1	Bit 0																		
EPPA3		EPPA2		EPPA1		EPPA0																																				
0	0	0	0	0	0	0	0																																			
Bit 7	6	5	4	3	2	1	Bit 0																																			
0x00c6_0002	EPORT Data Direction Register (EPDDR) <a href="#">See page 290.</a>	<table border="1"> <tr> <td>Bit 7</td> <td>6</td> <td>5</td> <td>4</td> <td>3</td> <td>2</td> <td>1</td> <td>Bit 0</td> </tr> <tr> <td>EPDD7</td> <td>EPDD6</td> <td>EPDD5</td> <td>EPDD4</td> <td>EPDD3</td> <td>EPDD2</td> <td>EPDD1</td> <td>EPDD0</td> </tr> <tr> <td>0</td> <td>0</td> <td>0</td> <td>0</td> <td>0</td> <td>0</td> <td>0</td> <td>0</td> </tr> <tr> <td>Bit 7</td> <td>6</td> <td>5</td> <td>4</td> <td>3</td> <td>2</td> <td>1</td> <td>Bit 0</td> </tr> </table>	Bit 7	6	5	4	3	2	1	Bit 0	EPDD7	EPDD6	EPDD5	EPDD4	EPDD3	EPDD2	EPDD1	EPDD0	0	0	0	0	0	0	0	0	Bit 7	6	5	4	3	2	1	Bit 0								
		Bit 7	6	5	4	3	2	1	Bit 0																																	
		EPDD7	EPDD6	EPDD5	EPDD4	EPDD3	EPDD2	EPDD1	EPDD0																																	
		0	0	0	0	0	0	0	0																																	
Bit 7	6	5	4	3	2	1	Bit 0																																			
0x00c6_0003	EPORT Port Interrupt Enable Register (EPIER) <a href="#">See page 291.</a>	<table border="1"> <tr> <td>Bit 7</td> <td>6</td> <td>5</td> <td>4</td> <td>3</td> <td>2</td> <td>1</td> <td>Bit 0</td> </tr> <tr> <td>EPIE7</td> <td>EPIE6</td> <td>EPIE5</td> <td>EPIE4</td> <td>EPIE3</td> <td>EPIE2</td> <td>EPIE1</td> <td>EPIE0</td> </tr> <tr> <td>0</td> <td>0</td> <td>0</td> <td>0</td> <td>0</td> <td>0</td> <td>0</td> <td>0</td> </tr> <tr> <td>Bit 7</td> <td>6</td> <td>5</td> <td>4</td> <td>3</td> <td>2</td> <td>1</td> <td>Bit 0</td> </tr> </table>	Bit 7	6	5	4	3	2	1	Bit 0	EPIE7	EPIE6	EPIE5	EPIE4	EPIE3	EPIE2	EPIE1	EPIE0	0	0	0	0	0	0	0	0	Bit 7	6	5	4	3	2	1	Bit 0								
		Bit 7	6	5	4	3	2	1	Bit 0																																	
		EPIE7	EPIE6	EPIE5	EPIE4	EPIE3	EPIE2	EPIE1	EPIE0																																	
		0	0	0	0	0	0	0	0																																	
Bit 7	6	5	4	3	2	1	Bit 0																																			
0x00c6_0004	EPORT Port Data Register (EPDR) <a href="#">See page 292.</a>	<table border="1"> <tr> <td>Bit 7</td> <td>6</td> <td>5</td> <td>4</td> <td>3</td> <td>2</td> <td>1</td> <td>Bit 0</td> </tr> <tr> <td>EPD7</td> <td>EPD6</td> <td>EPD5</td> <td>EPD4</td> <td>EPD3</td> <td>EPD2</td> <td>EPD1</td> <td>EPD0</td> </tr> <tr> <td>1</td> <td>1</td> <td>1</td> <td>1</td> <td>1</td> <td>1</td> <td>1</td> <td>1</td> </tr> <tr> <td>Bit 7</td> <td>6</td> <td>5</td> <td>4</td> <td>3</td> <td>2</td> <td>1</td> <td>Bit 0</td> </tr> </table>	Bit 7	6	5	4	3	2	1	Bit 0	EPD7	EPD6	EPD5	EPD4	EPD3	EPD2	EPD1	EPD0	1	1	1	1	1	1	1	1	Bit 7	6	5	4	3	2	1	Bit 0								
		Bit 7	6	5	4	3	2	1	Bit 0																																	
		EPD7	EPD6	EPD5	EPD4	EPD3	EPD2	EPD1	EPD0																																	
		1	1	1	1	1	1	1	1																																	
Bit 7	6	5	4	3	2	1	Bit 0																																			
0x00c6_0005	EPORT Port Pin Data Register (EPPDR) <a href="#">See page 292.</a>	<table border="1"> <tr> <td>Bit 7</td> <td>6</td> <td>5</td> <td>4</td> <td>3</td> <td>2</td> <td>1</td> <td>Bit 0</td> </tr> <tr> <td>EPPD7</td> <td>EPPD6</td> <td>EPPD5</td> <td>EPPD4</td> <td>EPPD3</td> <td>EPPD2</td> <td>EPPD1</td> <td>EPPD0</td> </tr> <tr> <td style="background-color: #cccccc;"></td> <td style="background-color: #cccccc;"></td> <td style="background-color: #cccccc;"></td> <td style="background-color: #cccccc;"></td> <td style="background-color: #cccccc;"></td> <td style="background-color: #cccccc;"></td> <td style="background-color: #cccccc;"></td> <td style="background-color: #cccccc;"></td> </tr> <tr> <td>P</td> <td>P</td> <td>P</td> <td>P</td> <td>P</td> <td>P</td> <td>P</td> <td>P</td> </tr> <tr> <td>Bit 7</td> <td>6</td> <td>5</td> <td>4</td> <td>3</td> <td>2</td> <td>1</td> <td>Bit 0</td> </tr> </table>	Bit 7	6	5	4	3	2	1	Bit 0	EPPD7	EPPD6	EPPD5	EPPD4	EPPD3	EPPD2	EPPD1	EPPD0									P	P	P	P	P	P	P	P	Bit 7	6	5	4	3	2	1	Bit 0
		Bit 7	6	5	4	3	2	1	Bit 0																																	
		EPPD7	EPPD6	EPPD5	EPPD4	EPPD3	EPPD2	EPPD1	EPPD0																																	
P	P	P	P	P	P	P	P																																			
Bit 7	6	5	4	3	2	1	Bit 0																																			
0x00c6_0006	EPORT Port Flag Register (EPFR) <a href="#">See page 293.</a>	<table border="1"> <tr> <td>Bit 7</td> <td>6</td> <td>5</td> <td>4</td> <td>3</td> <td>2</td> <td>1</td> <td>Bit 0</td> </tr> <tr> <td>EPF7</td> <td>EPF6</td> <td>EPF5</td> <td>EPF4</td> <td>EPF3</td> <td>EPF2</td> <td>EPF1</td> <td>EPF0</td> </tr> <tr> <td>0</td> <td>0</td> <td>0</td> <td>0</td> <td>0</td> <td>0</td> <td>0</td> <td>0</td> </tr> <tr> <td>Bit 7</td> <td>6</td> <td>5</td> <td>4</td> <td>3</td> <td>2</td> <td>1</td> <td>Bit 0</td> </tr> </table>	Bit 7	6	5	4	3	2	1	Bit 0	EPF7	EPF6	EPF5	EPF4	EPF3	EPF2	EPF1	EPF0	0	0	0	0	0	0	0	0	Bit 7	6	5	4	3	2	1	Bit 0								
		Bit 7	6	5	4	3	2	1	Bit 0																																	
		EPF7	EPF6	EPF5	EPF4	EPF3	EPF2	EPF1	EPF0																																	
		0	0	0	0	0	0	0	0																																	
Bit 7	6	5	4	3	2	1	Bit 0																																			
0x00c6_0007	Reserved	Writes have no effect, reads return 0s, and the access terminates without a transfer error exception.																																								

P = Current pin state    U = Unaffected     = Writes have no effect and the access terminates without a transfer error exception.

**Figure 2-4. Register Summary (Sheet 17 of 37)**

**System Memory Map**

Address	Register Name	Bit Number							
		Bit 7	6	5	4	3	2	1	Bit 0
0x00c6_0008 ↓ 0x00c6_ffff	Unimplemented	Access results in a bus monitor timeout generating an access termination transfer error.							

**Watchdog Timer (WDT)**

Address	Register Name	Bit Number								
		Bit 15	14	13	12	11	10	9	Bit 8	
0x00c7_0000 0x00c7_0001	Watchdog Control Register (WCR) <a href="#">See page 299.</a>	Read:	0	0	0	0	0	0	0	0
		Write:								
		Reset:	0	0	0	0	0	0	0	0
			Bit 7	6	5	4	3	2	1	Bit 0
		Read:	0	0	0	0	WAIT	DOZE	DBG	EN
		Write:								
		Reset:	0	0	0	0	1	1	1	1
0x00c7_0002 0x00c7_0003	Watchdog Modulus Register (WMR) <a href="#">See page 301.</a>		Bit 15	14	13	12	11	10	9	Bit 8
		Read:	WM15	WM14	WM13	WM12	WM11	WM10	WM9	WM8
		Write:								
		Reset:	1	1	1	1	1	1	1	1
			Bit 7	6	5	4	3	2	1	Bit 0
		Read:	WM7	WM6	WM5	WM4	WM3	WM2	WM1	WM0
		Write:								
		Reset:	1	1	1	1	1	1	1	1
0x00c7_0004 0x00c7_0005	Watchdog Count Register (WCNTR) <a href="#">See page 302.</a>		Bit 15	14	13	12	11	10	9	Bit 8
		Read:	WC15	WC14	WC13	WC12	WC11	WC10	WC9	WC8
		Write:								
		Reset:	1	1	1	1	1	1	1	1
			Bit 7	6	5	4	3	2	1	Bit 0
		Read:	WC7	WC6	WC5	WC4	WC3	WC2	WC1	WC0
		Write:								
		Reset:	1	1	1	1	1	1	1	1

P = Current pin state    U = Unaffected     = Writes have no effect and the access terminates without a transfer error exception.

**Figure 2-4. Register Summary (Sheet 18 of 37)**

Address	Register Name	Bit Number								
		Bit 15	14	13	12	11	10	9	Bit 8	
0x00c7_0006 0x00c7_0007	Watchdog Service Register (WSR) <a href="#">See page 303.</a>	Read:	WS15	WS14	WS13	WS12	WS11	WS10	WS9	WS8
		Write:								
		Reset:	0	0	0	0	0	0	0	0
			Bit 7	6	5	4	3	2	1	Bit 0
		Read:	WS7	WS6	WS5	WS4	WS3	WS2	WS1	WS0
		Write:								
		Reset:	0	0	0	0	0	0	0	0
0x00c7_0008 ↓ 0x00c7_ffff	Unimplemented	Access results in a bus monitor timeout generating an access termination transfer error.								

**Programmable Interrupt Timer 1 (PIT1) and Programming Interrupt Timer 2 (PIT2)**

Note: Addresses for PIT1 are at 0x00c8\_#### and addresses for PIT2 are at 0x00c9\_####.

Address	Register Name	Bit Number								
		Bit 15	14	13	12	11	10	9	Bit 8	
0x00c8_0000 0x00c8_0001 0x00c9_0000 0x00c9_0001	PIT Control and Status Register (PCSR) <a href="#">See page 309.</a>	Read:	0	0	0	0	PRE3	PRE2	PRE1	PRE0
		Write:								
		Reset:	0	0	0	0	0	0	0	0
			Bit 7	6	5	4	3	2	1	Bit 0
		Read:	0	PDOZE	PDBG	OVW	PIE	PIF	RLD	EN
		Write:								
		Reset:	0	0	0	0	0	0	0	0
0x00c8_0002 0x00c8_0003 0x00c9_0002 0x00c9_0003	PIT Modulus Register (PMR) <a href="#">See page 312.</a>	Read:	PM15	PM14	PM13	PM12	PM11	PM10	PM9	PM8
		Write:								
		Reset:	1	1	1	1	1	1	1	1
			Bit 7	6	5	4	3	2	1	Bit 0
		Read:	PM7	PM6	PM5	PM4	PM3	PM2	PM1	PM0
		Write:								
		Reset:	1	1	1	1	1	1	1	1

P = Current pin state    U = Unaffected     = Writes have no effect and the access terminates without a transfer error exception.

**Figure 2-4. Register Summary (Sheet 19 of 37)**

**System Memory Map**

Address	Register Name	Bit Number								
		Bit 15	14	13	12	11	10	9	Bit 8	
0x00c8_0004 0x00c8_0005 0x00c9_0004 0x00c9_0005	PIT Count Register (PCNTR) <a href="#">See page 313.</a>	Read:	PC15	PC14	PC13	PC12	PC11	PC10	PC9	PC8
Write:										
Reset:		1	1	1	1	1	1	1	1	
		Bit 7	6	5	4	3	2	1	Bit 0	
	Read:	PC7	PC6	PC5	PC4	PC3	PC2	PC1	PC0	
	Write:									
	Reset:	1	1	1	1	1	1	1	1	
		Bit 7	6	5	4	3	2	1	Bit 0	
0x00c8_0006 ↓ 0x00c8_0007	Unimplemented	Access results in the module generating an access termination transfer error.								
0x00ca_0008 ↓ 0x00ca_fff	Unimplemented	Access results in a bus monitor timeout generating an access termination transfer error.								
<b>Queued Analog-to-Digital Converter (QADC)</b>										
0x00ca_0000 0x00ca_0001	QADC Module Configuration Register (QADCMCR) <a href="#">See page 437.</a>	Read:	QSTOP	QDBG	0	0	0	0	0	0
Write:										
Reset:		0	0	0	0	0	0	0	0	
		Bit 7	6	5	4	3	2	1	Bit 0	
	Read:	SUPV	0	0	0	0	0	0	0	
	Write:									
	Reset:	1	0	0	0	0	0	0	0	
0x00ca_0002 0x00ca_0003	QADC Test Register (QADCTEST) <a href="#">See page 438.</a>	Access results in the module generating an access termination transfer error if not in test mode.								
		Bit 7	6	5	4	3	2	1	Bit 0	
		Access results in the module generating an access termination transfer error if not in test mode.								
P = Current pin state    U = Unaffected     = Writes have no effect and the access terminates without a transfer error exception.										

**Figure 2-4. Register Summary (Sheet 20 of 37)**

Address	Register Name	Bit Number																											
0x00ca_0004 0x00ca_0005	Reserved	Writes have no effect, reads return 0s, and the access terminates without a transfer error exception. Bit 7 6 5 4 3 2 1 Bit 0																											
		Writes have no effect, reads return 0s, and the access terminates without a transfer error exception. Bit 7 6 5 4 3 2 1 Bit 0																											
0x00ca_0006	QADC Port A Data Register (PORTQA) <a href="#">See page 439.</a>	<table border="1"> <tr> <td>Read:</td> <td>0</td> <td>0</td> <td>0</td> <td>PQA4</td> <td>PQA3</td> <td>0</td> <td>PQA1</td> <td>PQA0</td> </tr> <tr> <td>Write:</td> <td></td> <td></td> <td></td> <td></td> <td></td> <td></td> <td></td> <td></td> </tr> <tr> <td>Reset:</td> <td>0</td> <td>0</td> <td>0</td> <td>P</td> <td>P</td> <td>0</td> <td>P</td> <td>P</td> </tr> </table>	Read:	0	0	0	PQA4	PQA3	0	PQA1	PQA0	Write:									Reset:	0	0	0	P	P	0	P	P
Read:	0	0	0	PQA4	PQA3	0	PQA1	PQA0																					
Write:																													
Reset:	0	0	0	P	P	0	P	P																					
0x00ca_0007	QADC Port B Data Register (PORTQB) <a href="#">See page 439.</a>	<table border="1"> <tr> <td>Read:</td> <td>0</td> <td>0</td> <td>0</td> <td>0</td> <td>PQB3</td> <td>PQB2</td> <td>PQB1</td> <td>PQB0</td> </tr> <tr> <td>Write:</td> <td></td> <td></td> <td></td> <td></td> <td></td> <td></td> <td></td> <td></td> </tr> <tr> <td>Reset:</td> <td>0</td> <td>0</td> <td>0</td> <td>0</td> <td>P</td> <td>P</td> <td>P</td> <td>P</td> </tr> </table>	Read:	0	0	0	0	PQB3	PQB2	PQB1	PQB0	Write:									Reset:	0	0	0	0	P	P	P	P
Read:	0	0	0	0	PQB3	PQB2	PQB1	PQB0																					
Write:																													
Reset:	0	0	0	0	P	P	P	P																					
0x00ca_0008	QADC Port A Data Direction Register (DDRQA) <a href="#">See page 441.</a>	<table border="1"> <tr> <td>Read:</td> <td>0</td> <td>0</td> <td>0</td> <td>DDQA4</td> <td>DDQA3</td> <td>0</td> <td>DDQA1</td> <td>DDQA0</td> </tr> <tr> <td>Write:</td> <td></td> <td></td> <td></td> <td></td> <td></td> <td></td> <td></td> <td></td> </tr> <tr> <td>Reset:</td> <td>0</td> <td>0</td> <td>0</td> <td>0</td> <td>0</td> <td>0</td> <td>0</td> <td>0</td> </tr> </table>	Read:	0	0	0	DDQA4	DDQA3	0	DDQA1	DDQA0	Write:									Reset:	0	0	0	0	0	0	0	0
Read:	0	0	0	DDQA4	DDQA3	0	DDQA1	DDQA0																					
Write:																													
Reset:	0	0	0	0	0	0	0	0																					
0x00ca_0009	QADC Port B Data Direction Register (DDRQB) <a href="#">See page 441.</a>	<table border="1"> <tr> <td>Read:</td> <td>0</td> <td>0</td> <td>0</td> <td>0</td> <td>DDQB3</td> <td>DDQB2</td> <td>DDQB1</td> <td>DDQB0</td> </tr> <tr> <td>Write:</td> <td></td> <td></td> <td></td> <td></td> <td></td> <td></td> <td></td> <td></td> </tr> <tr> <td>Reset:</td> <td>0</td> <td>0</td> <td>0</td> <td>0</td> <td>0</td> <td>0</td> <td>0</td> <td>0</td> </tr> </table>	Read:	0	0	0	0	DDQB3	DDQB2	DDQB1	DDQB0	Write:									Reset:	0	0	0	0	0	0	0	0
Read:	0	0	0	0	DDQB3	DDQB2	DDQB1	DDQB0																					
Write:																													
Reset:	0	0	0	0	0	0	0	0																					
0x00ca_000a 0x00ca_000b	QADC Control Register 0 (QACR0) <a href="#">See page 442.</a>	<table border="1"> <tr> <td>Read:</td> <td>MUX</td> <td>0</td> <td>0</td> <td>TRG</td> <td>0</td> <td>0</td> <td>0</td> <td>0</td> </tr> <tr> <td>Write:</td> <td></td> <td></td> <td></td> <td></td> <td></td> <td></td> <td></td> <td></td> </tr> <tr> <td>Reset:</td> <td>0</td> <td>0</td> <td>0</td> <td>0</td> <td>0</td> <td>0</td> <td>0</td> <td>0</td> </tr> </table>	Read:	MUX	0	0	TRG	0	0	0	0	Write:									Reset:	0	0	0	0	0	0	0	0
Read:	MUX	0	0	TRG	0	0	0	0																					
Write:																													
Reset:	0	0	0	0	0	0	0	0																					
		<table border="1"> <tr> <td>Read:</td> <td>0</td> <td>QPR6</td> <td>QPR5</td> <td>QPR4</td> <td>QPR3</td> <td>QPR2</td> <td>QPR1</td> <td>QPR0</td> </tr> <tr> <td>Write:</td> <td></td> <td></td> <td></td> <td></td> <td></td> <td></td> <td></td> <td></td> </tr> <tr> <td>Reset:</td> <td>0</td> <td>0</td> <td>0</td> <td>1</td> <td>0</td> <td>0</td> <td>1</td> <td>1</td> </tr> </table>	Read:	0	QPR6	QPR5	QPR4	QPR3	QPR2	QPR1	QPR0	Write:									Reset:	0	0	0	1	0	0	1	1
Read:	0	QPR6	QPR5	QPR4	QPR3	QPR2	QPR1	QPR0																					
Write:																													
Reset:	0	0	0	1	0	0	1	1																					

P = Current pin state    U = Unaffected    = Writes have no effect and the access terminates without a transfer error exception.

**Figure 2-4. Register Summary (Sheet 21 of 37)**

System Memory Map

Address	Register Name	Bit Number								
		Bit 15	14	13	12	11	10	9	Bit 8	
0x00ca_000c 0x00ca_000d	QADC Control Register 1 (QACR1) <a href="#">See page 445.</a>	Read:	CIE1	PIE1	0	MQ112	MQ111	MQ110	MQ19	MQ18
		Write:			SSE1					
Reset:		0	0	0	0	0	0	0	0	
		Bit 7	6	5	4	3	2	1	Bit 0	
Read:		0	0	0	0	0	0	0	0	
Write:										
Reset:		0	0	0	0	0	0	0	0	
0x00ca_000e 0x00ca_000f	QADC Control Register 2 (QACR2) <a href="#">See page 448.</a>	Read:	CIE2	PIE2	0	MQ212	MQ211	MQ210	MQ29	MQ28
		Write:			SSE2					
Reset:		0	0	0	0	0	0	0	0	
		Bit 7	6	5	4	3	2	1	Bit 0	
Read:		RESUME	BQ26	BQ25	BQ24	BQ23	BQ22	BQ21	BQ20	
Write:										
Reset:		0	1	1	1	1	1	1	1	
0x00ca_0010 0x00ca_0011	QADC Status Register 0 (QASR0) <a href="#">See page 453.</a>	Read:	CF1	PF1	CF2	PF2	TOR1	TOR2	QS9	QS8
		Write:								
Reset:		0	0	0	0	0	0	0	0	
		Bit 7	6	5	4	3	2	1	Bit 0	
Read:		QS7	QS6	CWP5	CWP4	CWP3	CWP2	CWP1	CWP0	
Write:										
Reset:		0	0	0	0	0	0	0	0	

P = Current pin state    U = Unaffected     = Writes have no effect and the access terminates without a transfer error exception.

Figure 2-4. Register Summary (Sheet 22 of 37)

Address	Register Name	Bit Number								
		Bit 15	14	13	12	11	10	9	Bit 8	
0x00ca_0012 0x00ca_0013	QADC Status Register 1 (QASR1) <a href="#">See page 462.</a>	Read:	0	0	CWPQ15	CWPQ14	CWPQ13	CWPQ12	CWPQ11	CWPQ10
		Write:								
		Reset:	0	0	1	1	1	1	1	
		Bit 7 6 5 4 3 2 1 Bit 0								
		Read:	0	0	CWPQ25	CWPQ24	CWPQ23	CWPQ22	CWPQ21	CWPQ20
		Write:								
		Reset:	0	0	1	1	1	1	1	
		Bit 7 6 5 4 3 2 1 Bit 0								
0x00ca_0014 ↓ 0x00ca_01ff	Reserved	Writes have no effect, reads return 0s, and the access terminates without a transfer error exception.								
0x00ca_0200 0x00ca_027e	Conversion Command Word Register (CCW0-CCW63) <a href="#">See page 464.</a>	Read:	0	0	0	0	0	0	P	BYP
		Write:								
		Reset:	0	0	0	0	0	0	U	U
		Bit 7 6 5 4 3 2 1 Bit 0								
		Read:	IST1	IST0	CHAN5	CHAN4	CHAN3	CHAN2	CHAN1	CHAN0
		Write:								
		Reset:	U	U	U	U	U	U	U	U
0x00ca_0280 0x00ca_02fe	Right-Justified Unsigned Result Register (RJURR0-RJURR63) <a href="#">See page 468.</a>	Read:	0	0	0	0	0	0	RESULT	
		Write:								
		Reset:	0	0	0	0	0	0		
		Bit 7 6 5 4 3 2 1 Bit 0								
		Read:	RESULT							
		Write:								
		Reset:								

P = Current pin state    U = Unaffected     = Writes have no effect and the access terminates without a transfer error exception.

**Figure 2-4. Register Summary (Sheet 23 of 37)**

**System Memory Map**

Address	Register Name	Bit Number								
		Bit 15	14	13	12	11	10	9	Bit 8	
0x00ca_0300 0x00ca_037e	Left-Justified Signed Result Register (LJSRR0-LJSRR63) <a href="#">See page 469.</a>	Read:	RESULT							
		Write:	S							
		Reset:								
		Bit 7 6 5 4 3 2 1 Bit 0								
		Read:	RESULT	0	0	0	0	0	0	
		Write:								
		Reset:		0	0	0	0	0	0	
0x00ca_0380 0x00ca_03fe	Left-Justified Unsigned Result Register (LJURR0-LJURR63) <a href="#">See page 470.</a>	Read:	RESULT							
		Write:								
		Reset:								
		Bit 7 6 5 4 3 2 1 Bit 0								
		Read:	RESULT	0	0	0	0	0	0	
		Write:								
		Reset:		0	0	0	0	0	0	
0x00ca_0400 ↓ 0x00ca_ffff	Unimplemented	Access results in a bus monitor timeout generating an access termination transfer error.								
<b>Serial Peripheral Interface (SPI)</b>										
0x00cb_0000	SPI Control Register 1 (SPICR1) <a href="#">See page 402.</a>	Bit 7 6 5 4 3 2 1 Bit 0								
		Read:	SPIE	SPE	SWOM	MSTR	CPOL	CPHA	SSOE	LSBFE
		Write:								
		Reset:	0	0	0	0	0	1	0	0
0x00cb_0001	SPI Control Register 2 (SPICR2) <a href="#">See page 405.</a>	Bit 7 6 5 4 3 2 1 Bit 0								
		Read:	0	0	0	0	0	0	SPISDOZ	SPC0
		Write:								
		Reset:	0	0	0	0	0	0	0	0

P = Current pin state    U = Unaffected     = Writes have no effect and the access terminates without a transfer error exception.

**Figure 2-4. Register Summary (Sheet 24 of 37)**



Address	Register Name	Bit Number								
		Bit 7	6	5	4	3	2	1	Bit 0	
0x00cb_0002	SPI Baud Rate Register (SPIBR) <a href="#">See page 406.</a>	Read:	0	SPPR6	SPPR5	SPPR4	0	SPR2	SPR1	SPR0
		Write:								
		Reset:	0	0	0	0	0	0	0	0
0x00cb_0003	SPI Status Register (SPISR) <a href="#">See page 408.</a>	Read:	SPIF	WCOL	0	MODF	0	0	0	0
		Write:								
		Reset:	0	0	0	0	0	0	0	0
0x00cb_0004	Reserved	Writes have no effect, reads return 0s, and the access terminates without a transfer error exception.								
0x00cb_0005	SPI Data Register (SPIDR) <a href="#">See page 409.</a>	Read:	Bit 7	6	5	4	3	2	1	Bit 0
		Write:								
		Reset:	0	0	0	0	0	0	0	0
0x00cb_0006	SPI Pullup and Reduced Drive Register (SPIPURD) <a href="#">See page 410.</a>	Read:	0	0	RSVD5	RDPSP	0	0	RSVD1	PUPSP
		Write:								
		Reset:	0	0	0	0	0	0	0	0
0x00cb_0007	SPI Port Data Register (SPIPORT) <a href="#">See page 411.</a>	Read:	RSVD7	RSVD6	RSVD5	RSVD4	PORTSP3	PORTSP2	PORTSP1	PORTSP0
		Write:								
		Reset:	0	0	0	0	0	0	0	0
0x00cb_0008	SPI Port Data Direction Register (SPIDDR) <a href="#">See page 412.</a>	Read:	RSVD7	RSVD6	RSVD5	RSVD4	DDRSP3	DDRSP2	DDRSP1	DDRSP0
		Write:								
		Reset:	0	0	0	0	0	0	0	0
0x00cb_0009	Reserved	Writes have no effect, reads return 0s, and the access terminates without a transfer error exception.								
0x00cb_000f										

P = Current pin state    U = Unaffected     = Writes have no effect and the access terminates without a transfer error exception.

**Figure 2-4. Register Summary (Sheet 25 of 37)**

**System Memory Map**

Address	Register Name	Bit Number							
		Bit 7	6	5	4	3	2	1	Bit 0
0x00cb_0010 ↓ 0x00cb_ffff	Unimplemented	Access results in a bus monitor timeout generating an access termination transfer error.							

**Serial Communications Interface 1 (SCI1) and Serial Communications Interface 2 (SCI2)**

Note: Addresses for SCI1 are at 0x00cc\_#### and addresses for SCI2 are at 0x00cd\_####.

		Bit Number								
		Bit 7	6	5	4	3	2	1	Bit 0	
0x00cc_0000	SCI Baud Rate Register High (SCIBDH) <a href="#">See page 360.</a>	Read:	0	0	0	SBR12	SBR11	SBR10	SBR9	SBR8
0x00cd_0000		Write:								
		Reset:	0	0	0	0	0	0	0	0
		Bit Number								
		Bit 7	6	5	4	3	2	1	Bit 0	
0x00cc_0001	SCI Baud Rate Register Low (SCIBDL) <a href="#">See page 360.</a>	Read:	SBR7	SBR6	SBR5	SBR4	SBR3	SBR2	SBR1	SBR0
0x00cd_0001		Write:								
		Reset:	0	0	0	0	0	1	0	0
		Bit Number								
		Bit 7	6	5	4	3	2	1	Bit 0	
0x00cc_0002	SCI Control Register 1 (SCICR1) <a href="#">See page 361.</a>	Read:	LOOPS	WOMS	RSRC	M	WAKE	ILT	PE	PT
0x00cd_0002		Write:								
		Reset:	0	0	0	0	0	0	0	0
		Bit Number								
		Bit 7	6	5	4	3	2	1	Bit 0	
0x00cc_0003	SCI Control Register 2 (SCICR2) <a href="#">See page 364.</a>	Read:	TIE	TCIE	RIE	ILIE	TE	RE	RWU	SBK
0x00cd_0003		Write:								
		Reset:	0	0	0	0	0	0	0	0
		Bit Number								
		Bit 7	6	5	4	3	2	1	Bit 0	
0x00cc_0004	SCI Status Register 1 (SCISR1) <a href="#">See page 366.</a>	Read:	TDRE	TC	RDRF	IDLE	OR	NF	FE	PF
0x00cd_0004		Write:								
		Reset:	1	1	0	0	0	0	0	0
		Bit Number								
		Bit 7	6	5	4	3	2	1	Bit 0	
0x00cc_0005	SCI Status Register 2 (SCISR2) <a href="#">See page 369.</a>	Read:	0	0	0	0	0	0	0	RAF
0x00cd_0005		Write:								
		Reset:	0	0	0	0	0	0	0	0

P = Current pin state    U = Unaffected     = Writes have no effect and the access terminates without a transfer error exception.

**Figure 2-4. Register Summary (Sheet 26 of 37)**

Address	Register Name	Bit Number								
		Bit 7	6	5	4	3	2	1	Bit 0	
0x00cc_0006 0x00cd_0006	SCI Data Register High (SCIDRH) <a href="#">See page 370.</a>	Read:	R8	T8	0	0	0	0	0	0
		Write:								
		Reset:	0	0	0	0	0	0	0	0
0x00cc_0007 0x00cd_0007	SCI Data Register Low (SCIDRL) <a href="#">See page 370.</a>	Read:	R7	R6	R5	R4	R3	R2	R1	R0
		Write:	T7	T6	T5	T4	T3	T2	T1	T0
		Reset:	0	0	0	0	0	0	0	0
0x00cc_0008 0x00cd_0008	SCI Pullup and Reduced Drive Register (SCIPURD) <a href="#">See page 371.</a>	Read:	SCISDOZ	0	RSVD5	RDPSCI	0	0	RSVD1	PUPSCI
		Write:								
		Reset:	0	0	0	0	0	0	0	0
0x00cc_0009 0x00cd_0009	SCI Port Data Register (SCIPOINT) <a href="#">See page 372.</a>	Read:	RSVD7	RSVD6	RSVD5	RSVD4	RSVD3	RSVD2	PORTSC1	PORTSC0
		Write:								
		Reset:	0	0	0	0	0	0	0	0
0x00cc_000a 0x00cd_000a	SCI Data Direction Register (SCIDDR) <a href="#">See page 373.</a>	Read:	RSVD7	RSVD6	RSVD5	RSVD4	RSVD3	RSVD2	DDRSC1	DDRSC0
		Write:								
		Reset:	0	0	0	0	0	0	0	0
0x00cc_000b ↓ 0x00cc_000f 0x00cd_000b ↓ 0x00cd_000f	Reserved	Writes have no effect, reads return 0s, and the access terminates without a transfer error exception.								
0x00cc_0010 ↓ 0x00cc_ffff 0x00cd_0010 ↓ 0x00cd_ffff	Unimplemented	Access results in a bus monitor timeout generating an access termination transfer error.								

P = Current pin state    U = Unaffected     = Writes have no effect and the access terminates without a transfer error exception.

**Figure 2-4. Register Summary (Sheet 27 of 37)**

**System Memory Map**

Address                      Register Name    Bit Number

**Timer 1 (TIM1) and Timer 2 (TIM2)**

Note: Addresses for TIM1 are at 0x00ce\_#### and addresses for TIM2 are at 0x00cf\_####.

		Bit Number								
		Bit 7	6	5	4	3	2	1	Bit 0	
0x00ce_0000 0x00cf_0000	Timer Input Capture/ Output Compare Select Register (TIMIOS) <a href="#">See page 324.</a>	Read:	0	0	0	0	IOS3	IOS2	IOS1	IOS0
		Write:	[Greyed out]							
		Reset:	0	0	0	0	0	0	0	0
0x00ce_0001 0x00cf_0001	Timer Compare Force Register (TIMCFORC) <a href="#">See page 325.</a>	Read:	0	0	0	0	FOC3	FOC2	FOC1	FOC0
		Write:	[Greyed out]							
		Reset:	0	0	0	0	0	0	0	0
0x00ce_0002 0x00cf_0002	Timer Output Compare 3 Mask Register (TIMOC3M) <a href="#">See page 326.</a>	Read:	0	0	0	0	OC3M3	OC3M2	OC3M1	OC3M0
		Write:	[Greyed out]							
		Reset:	0	0	0	0	0	0	0	0
0x00ce_0003 0x00cf_0003	Timer Output Compare 3 Data Register (TIMOC3D) <a href="#">See page 327.</a>	Read:	0	0	0	0	OC3D3	OC3D2	OC3D1	OC3D0
		Write:	[Greyed out]							
		Reset:	0	0	0	0	0	0	0	0
0x00ce_0004 0x00cf_0004	Timer Counter Register High (TIMCNTH) <a href="#">See page 328.</a>	Read:	Bit 15	14	13	12	11	10	9	Bit 8
		Write:	[Greyed out]							
		Reset:	0	0	0	0	0	0	0	0
0x00ce_0005 0x00cf_0005	Timer Counter Register Low (TIMCNTL) <a href="#">See page 328.</a>	Read:	Bit 7	6	5	4	3	2	1	Bit 0
		Write:	[Greyed out]							
		Reset:	0	0	0	0	0	0	0	0
0x00ce_0006 0x00cf_0006	Timer System Control Register 1 (TIMSCR1) <a href="#">See page 329.</a>	Read:	TIMEN	0	0	TFFCA	0	0	0	0
		Write:		[Greyed out]						
		Reset:	0	0	0	0	0	0	0	0

P = Current pin state    U = Unaffected    [Greyed out] = Writes have no effect and the access terminates without a transfer error exception.

**Figure 2-4. Register Summary (Sheet 28 of 37)**

Address	Register Name	Bit Number								
		Bit 7	6	5	4	3	2	1	Bit 0	
0x00ce_0007 0x00cf_0007	Reserved	Writes have no effect, reads return 0s, and the access terminates without a transfer error exception.								
0x00ce_0008 0x00cf_0008	Timer Toggle on Overflow Register (TIMTOV) <a href="#">See page 330.</a>	Read:	0	0	0	0	TOV3	TOV2	TOV1	TOV0
		Write:	[Greyed out]							
		Reset:	0	0	0	0	0	0	0	0
0x00ce_0009 0x00cf_0009	Timer Control Register 1 (TIMCTL1) <a href="#">See page 331.</a>	Read:	OM3	OL3	OM2	OL2	OM1	OL1	OM0	OL0
		Write:								
		Reset:	0	0	0	0	0	0	0	0
0x00ce_000a 0x00cf_000a	Reserved	Writes have no effect, reads return 0s, and the access terminates without a transfer error exception.								
0x00ce_000b 0x00cf_000b	Timer Control Register 2 (TIMCTL2) <a href="#">See page 332.</a>	Read:	EDG3B	EDG3A	EDG2B	EDG2A	EDG1B	EDG1A	EDG0B	EDG10
		Write:								
		Reset:	0	0	0	0	0	0	0	0
0x00ce_000c 0x00cf_000c	Timer Interrupt Enable Register (TIMIE) <a href="#">See page 333.</a>	Read:	0	0	0	0	C3I	C2I	C1I	C0I
		Write:	[Greyed out]							
		Reset:	0	0	0	0	0	0	0	0
0x00ce_000d 0x00cf_000d	Timer System Control Register 2 (TIMSCR2) <a href="#">See page 334.</a>	Read:	TOI	0	PUPT	RDPT	TCRE	PR2	PR1	PR0
		Write:		[Greyed out]						
		Reset:	0	0	0	0	0	0	0	0
0x00ce_000e 0x00cf_000e	Timer Flag Register 1 (TIMFLG1) <a href="#">See page 336.</a>	Read:	0	0	0	0	C3F	C2F	C1F	C0F
		Write:	[Greyed out]							
		Reset:	0	0	0	0	0	0	0	0

P = Current pin state    U = Unaffected    [Greyed out] = Writes have no effect and the access terminates without a transfer error exception.

**Figure 2-4. Register Summary (Sheet 29 of 37)**

**System Memory Map**

Address	Register Name	Bit Number								
		Bit 7	6	5	4	3	2	1	Bit 0	
0x00ce_000f 0x00cf_000f	Timer Flag Register 2 (TIMFLG2) <a href="#">See page 338.</a>	Read:	TOF	0	0	0	0	0	0	0
		Write:								
		Reset:	0	0	0	0	0	0	0	0
0x00ce_0010 0x00cf_0010	Timer Channel 0 Register High (TIMC0H) <a href="#">See page 338.</a>	Read:	Bit 15	14	13	12	11	10	9	Bit 8
		Write:	Bit 15	14	13	12	11	10	9	Bit 8
		Reset:	0	0	0	0	0	0	0	0
0x00ce_0011 0x00cf_0011	Timer Channel 0 Register Low (TIMC0L) <a href="#">See page 338.</a>	Read:	Bit 7	6	5	4	3	2	1	Bit 0
		Write:	Bit 7	6	5	4	3	2	1	Bit 0
		Reset:	0	0	0	0	0	0	0	0
0x00ce_0012 0x00cf_0012	Timer Channel 1 Register High (TIMC1H) <a href="#">See page 338.</a>	Read:	Bit 15	14	13	12	11	10	9	Bit 8
		Write:	Bit 15	14	13	12	11	10	9	Bit 8
		Reset:	0	0	0	0	0	0	0	0
0x00ce_0013 0x00cf_0013	Timer Channel 1 Register Low (TIMC1L) <a href="#">See page 338.</a>	Read:	Bit 7	6	5	4	3	2	1	Bit 0
		Write:	Bit 7	6	5	4	3	2	1	Bit 0
		Reset:	0	0	0	0	0	0	0	0
0x00ce_0014 0x00cf_0014	Timer Channel 2 Register High (TIMC2H) <a href="#">See page 338.</a>	Read:	Bit 15	14	13	12	11	10	9	Bit 8
		Write:	Bit 15	14	13	12	11	10	9	Bit 8
		Reset:	0	0	0	0	0	0	0	0
0x00ce_0015 0x00cf_0015	Timer Channel 2 Register Low (TIMC2L) <a href="#">See page 338.</a>	Read:	Bit 7	6	5	4	3	2	1	Bit 0
		Write:	Bit 7	6	5	4	3	2	1	Bit 0
		Reset:	0	0	0	0	0	0	0	0
0x00ce_0016 0x00cf_0016	Timer Channel 3 Register High (TIMC3H) <a href="#">See page 338.</a>	Read:	Bit 15	14	13	12	11	10	9	Bit 8
		Write:	Bit 15	14	13	12	11	10	9	Bit 8
		Reset:	0	0	0	0	0	0	0	0

P = Current pin state    U = Unaffected



= Writes have no effect and the access terminates without a transfer error exception.

**Figure 2-4. Register Summary (Sheet 30 of 37)**

Address	Register Name	Bit Number								
		Bit 7	6	5	4	3	2	1	Bit 0	
0x00ce_0017 0x00cf_0017	Timer Channel 3 Register Low (TIMC3L) <a href="#">See page 338.</a>	Read:	Bit 7	6	5	4	3	2	1	Bit 0
		Write:	Bit 7	6	5	4	3	2	1	Bit 0
		Reset:	0	0	0	0	0	0	0	0
0x00ce_0018 0x00cf_0018	Pulse Accumulator Control Register (TIMPACTL) <a href="#">See page 339.</a>	Read:	0	PAE	PAMOD	PEDGE	CLK1	CLK0	PAOVI	PAI
		Write:		PAE	PAMOD	PEDGE	CLK1	CLK0	PAOVI	PAI
		Reset:	0	0	0	0	0	0	0	0
0x00ce_0019 0x00cf_0019	Pulse Accumulator Flag Register (TIMPAFLG) <a href="#">See page 341.</a>	Read:	0	0	0	0	0	0	PAOVF	PAIF
		Write:							PAOVF	PAIF
		Reset:	0	0	0	0	0	0	0	0
0x00ce_001a 0x00cf_001a	Pulse Accumulator Counter Register High (TIMPACNTH) <a href="#">See page 342.</a>	Read:	Bit 15	14	13	12	11	10	9	Bit 8
		Write:	Bit 15	14	13	12	11	10	9	Bit 8
		Reset:	0	0	0	0	0	0	0	0
0x00ce_001b 0x00cf_001b	Pulse Accumulator Counter Register Low (TIMPACNTL) <a href="#">See page 342.</a>	Read:	Bit 7	6	5	4	3	2	1	Bit 0
		Write:	Bit 7	6	5	4	3	2	1	Bit 0
		Reset:	0	0	0	0	0	0	0	0
0x00ce_001c 0x00cf_001c	Reserved	Writes have no effect, reads return 0s, and the access terminates without a transfer error exception.								
		Read:	0	0	0	0	PORTT3	PORTT2	PORTT1	PORTT0
0x00ce_001d 0x00cf_001d	Timer Port Data Register (TIMPORT) <a href="#">See page 343.</a>	Write:					PORTT3	PORTT2	PORTT1	PORTT0
		Reset:	0	0	0	0	0	0	0	0
		Read:	0	0	0	0	DDRT3	DDRT2	DDRT1	DDRT0
0x00ce_001e 0x00cf_001e	Timer Port Data Direction Register (TIMDDR) <a href="#">See page 344.</a>	Write:					DDRT3	DDRT2	DDRT1	DDRT0
		Reset:	0	0	0	0	0	0	0	0

P = Current pin state    U = Unaffected     = Writes have no effect and the access terminates without a transfer error exception.

**Figure 2-4. Register Summary (Sheet 31 of 37)**

**System Memory Map**

Address	Register Name	Bit Number								
		Bit 7	6	5	4	3	2	1	Bit 0	
0x00ce_001f 0x00cf_001f	Timer Test Register (TIMTST) <a href="#">See page 345.</a>	Read:	0	0	0	0	0	0	0	0
		Write:								
		Reset:	0	0	0	0	0	0	0	0
0x00ce_0020 ↓ 0x00ce_ffff 0x00cf_0030 ↓ 0x00cf_ffff	Unimplemented	Access results in the module generating an access termination transfer error.								

**Second Generation FLASH for M-CORE (SGFM)**

Address	Register Name	Bit Number								
		Bit 15	14	13	12	11	10	9	Bit 8	
0x00d0_0000 0x00d0_0001	SGFM Module Configuration Register (SGFMCCR) <a href="#">See page 213.</a>	Read:	0	FRZ	0	EME	0	LOCK	0	0
		Write:								
		Reset:	0	0	0	Note 1	0	0	0	0
		Read:	CBEIE	CCIE	KEYACC	0	0	0	BKSEL	
		Write:								
		Reset:	0	0	0	0	0	0	0	0
		Note:	1. Reset state determined by chip reset configuration.							
0x00d0_0002	SGFM Clock Divider Register (SGFMCLKD) <a href="#">See page 215.</a>	Read:	DIVLD	PRDIV	DIV5	DIV4	DIV3	DIV2	DIV1	DIV0
		Write:								
		Reset:	0	0	0	0	0	0	0	0
0x00d0_0003	Unimplemented	Access results in the module generating an access termination transfer error.								

P = Current pin state    U = Unaffected    = Writes have no effect and the access terminates without a transfer error exception.

**Figure 2-4. Register Summary (Sheet 32 of 37)**



Address	Register Name	Bit Number								
		Bit 7	6	5	4	3	2	1	Bit 0	
0x00d0_0004	SGFM Test Register (SGFMTST) <a href="#">See page 216.</a>	Read:	RSVD7	RSVD6	RSVD5	RSVD4	0	0	RSVD1	RSVD0
		Write:								
		Reset:	0	0	0	0	0	0	0	0
0x00d0_0005 ↓ 0x00d0_0007	Unimplemented	Access results in the module generating an access termination transfer error.								
0x00d0_0008 0x00d0_0009 0x00d0_000a 0x00d0_000b	SGFM Security Register (SGFMSEC) <a href="#">See page 217.</a>	Bit 31 30 29 28 27 26 25 Bit 24								
		Read:	KEYEN	SECSTAT	0	0	0	0	0	0
	Write:									
	Reset:	F <sup>(1)</sup>	Note 2	0	0	0	0	0	0	
		Bit 23 22 21 20 19 18 17 Bit 16								
	Read:	0	0	0	0	0	0	0	0	
	Write:									
	Reset:	0	0	0	0	0	0	0	0	
		Bit 15 14 13 12 11 10 9 Bit 8								
	Read:	SEC15	SEC14	SEC13	SEC12	SEC11	SEC10	SEC9	SEC8	
	Write:									
	Reset:	F <sup>(1)</sup>	F <sup>(1)</sup>	F <sup>(1)</sup>	F <sup>(1)</sup>	F <sup>(1)</sup>	F <sup>(1)</sup>	F <sup>(1)</sup>	F <sup>(1)</sup>	
		Bit 7 6 5 4 3 2 1 Bit 0								
	Read:	SEC7	SEC6	SEC5	SEC4	SEC3	SEC2	SEC1	SEC0	
	Write:									
	Reset:	F <sup>(1)</sup>	F <sup>(1)</sup>	F <sup>(1)</sup>	F <sup>(1)</sup>	F <sup>(1)</sup>	F <sup>(1)</sup>	F <sup>(1)</sup>	F <sup>(1)</sup>	

Notes:

1. Reset state loaded from FLASH array during reset.
2. Reset state determined by security state of module.

P = Current pin state    U = Unaffected



= Writes have no effect and the access terminates without a transfer error exception.

**Figure 2-4. Register Summary (Sheet 33 of 37)**

System Memory Map

Address	Register Name	Bit Number								
		Bit 31	30	29	28	27	26	25	Bit 24	
0x00d0_000c 0x00d0_000d 0x00d0_000e 0x00d0_000f	SGFM Monitor Data Register (SGFMMNTR) <a href="#">See page 219.</a>	Read:	RSVD31	RSVD30	RSVD29	RSVD28	RSVD27	RSVD26	RSVD25	RSVD24
		Write:								
		Reset:	Note 1							
			Bit 23	22	21	20	19	18	17	Bit 16
	Read:	RSVD23	RSVD22	RSVD21	RSVD20	RSVD19	RSVD18	RSVD17	RSVD16	
	Write:									
	Reset:	Note 1								
		Bit 15	14	13	12	11	10	9	Bit 8	
	Read:	RSVD15	RSVD14	RSVD13	RSVD12	RSVD11	RSVD10	RSVD9	RSVD8	
	Write:									
	Reset:	Note 1								
		Bit 7	6	5	4	3	2	1	Bit 0	
	Read:	RSVD7	RSVD6	RSVD5	RSVD4	RSVD3	RSVD2	RSVD1	RSVD0	
	Write:									
	Reset:	Note 1								
		Note 1. SGFMMNTR does not have a default reset state.								
0x00d0_0010 0x00d0_0011	SGFM Protection Register (SGFMPPROT) <a href="#">See page 220.</a>	Read:	PROT15	PROT14	PROT13	PROT12	PROT11	PROT10	PROT9	PROT8
		Write:								
		Reset:	F <sup>(1)</sup>	F <sup>(1)</sup>	F <sup>(1)</sup>	F <sup>(1)</sup>	F <sup>(1)</sup>	F <sup>(1)</sup>	F <sup>(1)</sup>	F <sup>(1)</sup>
			Bit 7	6	5	4	3	2	1	Bit 0
	Read:	PROT7	PROT6	PROT5	PROT4	PROT3	PROT2	PROT1	PROT0	
	Write:									
	Reset:	F <sup>(1)</sup>	F <sup>(1)</sup>	F <sup>(1)</sup>	F <sup>(1)</sup>	F <sup>(1)</sup>	F <sup>(1)</sup>	F <sup>(1)</sup>	F <sup>(1)</sup>	
		Note 1. Reset state loaded from FLASH configuration field during reset.								
0x00d0_0012 ↓ 0x00d0_0013	Unimplemented	Access results in the module generating an access termination transfer error.								

P = Current pin state    U = Unaffected     = Writes have no effect and the access terminates without a transfer error exception.

Figure 2-4. Register Summary (Sheet 34 of 37)

Address	Register Name	Bit Number								
		Bit 15	14	13	12	11	10	9	Bit 8	
0x00d0_0014 0x00d0_0015	SGFM Supervisor Access Register (SGFMASACC) <a href="#">See page 221.</a>	Read:	SUPV15	SUPV14	SUPV13	SUPV12	SUPV11	SUPV10	SUPV9	SUPV8
		Write:								
		Reset:	F <sup>(1)</sup>	F <sup>(1)</sup>	F <sup>(1)</sup>	F <sup>(1)</sup>	F <sup>(1)</sup>	F <sup>(1)</sup>	F <sup>(1)</sup>	F <sup>(1)</sup>
			Bit 7	6	5	4	3	2	1	Bit 0
		Read:	SUPV7	SUPV6	SUPV5	SUPV4	SUPV3	SUPV2	SUPV1	SUPV0
		Write:								
		Reset:	F <sup>(1)</sup>	F <sup>(1)</sup>	F <sup>(1)</sup>	F <sup>(1)</sup>	F <sup>(1)</sup>	F <sup>(1)</sup>	F <sup>(1)</sup>	F <sup>(1)</sup>
Note 1. Reset state loaded from FLASH array during reset.										
0x00d0_0016 0x00d0_0017	SGFM Data Access Register (SGFMDACC) <a href="#">See page 223.</a>	Read:	DATA15	DATA14	DATA13	DATA12	DATA11	DATA10	DATA9	DATA8
		Write:								
		Reset:	F <sup>(1)</sup>	F <sup>(1)</sup>	F <sup>(1)</sup>	F <sup>(1)</sup>	F <sup>(1)</sup>	F <sup>(1)</sup>	F <sup>(1)</sup>	F <sup>(1)</sup>
			Bit 7	6	5	4	3	2	1	Bit 0
		Read:	DATA7	DATA6	DATA5	DATA4	DATA3	DATA2	DATA1	DATA0
		Write:								
		Reset:	F <sup>(1)</sup>	F <sup>(1)</sup>	F <sup>(1)</sup>	F <sup>(1)</sup>	F <sup>(1)</sup>	F <sup>(1)</sup>	F <sup>(1)</sup>	F <sup>(1)</sup>
Note 1. Reset state loaded from FLASH configuration field during reset.										
0x00d0_0018	SGFM Test Status Register (SGFMTSTAT) <a href="#">See page 224.</a>	Read:	0	0	0	0	RSVD3	0	RSVD1	RSVD0
		Write:								
		Reset:	0	0	0	0	0	0	0	0
			Bit 7	6	5	4	3	2	1	Bit 0
0x00d0_0019 ↓ 0x00d0_001b	Unimplemented	Access results in the module generating an access termination transfer error.								
0x00d0_001c	SGFM User Status Register (SGFMUSTAT) <a href="#">See page 224.</a>	Read:	CBEIF	CCIF	PVIOL	ACCERR	0	BLANK	0	0
		Write:								
		Reset:	1	1	0	0	0	0	0	0

P = Current pin state    U = Unaffected     = Writes have no effect and the access terminates without a transfer error exception.

**Figure 2-4. Register Summary (Sheet 35 of 37)**

**System Memory Map**

Address	Register Name	Bit Number								
		Bit 7	6	5	4	3	2	1	Bit 0	
0x00d0_001d ↓ 0x00d0_001f	Unimplemented	Access results in a bus monitor timeout generating an access termination transfer error.								
0x00d0_0020	SGFM Command Buffer and Register (SGFMCMD) <a href="#">See page 226.</a>	Read: 0	CMD6	CMD5	CMD4	CMD3	CMD2	CMD1	CMD0	
		Write:								
		Reset:	0	0	0	0	0	0	0	
0x00d0_0021 ↓ 0x00d0_0023	Unimplemented	Access results in a bus monitor timeout generating an access termination transfer error.								
0x00d0_0024 0x00d0_0025	SGFM Control Register (SGFMCTL) <a href="#">See page 227.</a>	Read: RSVD15	0	0	0	0	0	0	0	
		Write:								
		Reset:	0	0	0	0	0	0	0	
		Read:	RSVD7	RSVD6	RSVD5	RSVD4	RSVD3	RSVD2	RSVD1	RSVD0
		Write:								
		Reset:	0	0	0	0	0	0	0	
0x00d0_0026 0x00d0_0027	SGFM Address Register (SGMADR) <a href="#">See page 228.</a>	Read: 0	RSVD14	RSVD13	RSVD12	RSVD11	RSVD10	RSVD9	RSVD8	
		Write:								
		Reset:	0	0	0	0	0	0	0	
		Read:	RSVD7	RSVD6	RSVD5	RSVD4	RSVD3	RSVD2	RSVD1	RSVD0
		Write:								
		Reset:	0	0	0	0	0	0	0	

P = Current pin state    U = Unaffected    = Writes have no effect and the access terminates without a transfer error exception.

**Figure 2-4. Register Summary (Sheet 36 of 37)**

Address	Register Name	Bit Number								
		Bit 31	30	29	28	27	26	25	Bit 24	
0x00d0_0028 0x00d0_0029 0x00d0_002a 0x00d0_002b	SGFM Data Register (SGFM DATA) <a href="#">See page 229.</a>	Read:	RSVD31	RSVD30	RSVD29	RSVD28	RSVD27	RSVD26	RSVD25	RSVD24
		Write:								
		Reset:	0	0	0	0	0	0	0	0
		Bit 23 22 21 20 19 18 17 Bit 16								
		Read:	RSVD23	RSVD22	RSVD21	RSVD20	RSVD19	RSVD18	RSVD17	RSVD16
		Write:								
		Reset:	0	0	0	0	0	0	0	0
		Bit 15 14 13 12 11 10 9 Bit 8								
		Read:	RSVD15	RSVD14	RSVD13	RSVD12	RSVD11	RSVD10	RSVD9	RSVD8
		Write:								
		Reset:	0	0	0	0	0	0	0	0
		Bit 7 6 5 4 3 2 1 Bit 0								
		Read:	RSVD7	RSVD6	RSVD5	RSVD4	RSVD3	RSVD2	RSVD1	RSVD0
		Write:								
		Reset:	0	0	0	0	0	0	0	0

P = Current pin state    U = Unaffected     = Writes have no effect and the access terminates without a transfer error exception.

**Figure 2-4. Register Summary (Sheet 37 of 37)**



## Section 3. Signal Description

### 3.1 Contents

3.2	Introduction . . . . .	97
3.3	Package Pinout Summary . . . . .	98
3.4	Chip Specific Implementation Signal Issues . . . . .	109
3.4.1	$\overline{\text{RSTOUT}}$ Signal Functions . . . . .	109
3.4.2	$\overline{\text{INT}}$ Signal Functions . . . . .	110
3.4.3	Serial Peripheral Interface (SPI) Pin Functions . . . . .	110
3.4.4	Serial Communications Interface (SCI1 and SCI2) Pin Functions . . . . .	111
3.4.5	Timer 1 and Timer 2 Pin Functions . . . . .	112
3.4.6	Queued Analog-to-Digital Converter (QADC) Pin Functions . . . . .	112
3.5	Signal Descriptions . . . . .	113
3.5.1	Reset Signals . . . . .	113
3.5.1.1	Reset In ( $\overline{\text{RESET}}$ ) . . . . .	113
3.5.1.2	Reset Out ( $\overline{\text{RSTOUT}}$ ) . . . . .	113
3.5.2	Phase-Lock Loop (PLL) and Clock Signals . . . . .	113
3.5.2.1	External Clock In (EXTAL) . . . . .	113
3.5.2.2	Crystal (XTAL) . . . . .	114
3.5.2.3	Clock Out (CLKOUT) . . . . .	114
3.5.2.4	PLL Enable (PLLEN) . . . . .	114
3.5.3	External Memory Interface Signals . . . . .	114
3.5.3.1	Data Bus (D[31:0]) . . . . .	114
3.5.3.2	Show Cycle Strobe ( $\overline{\text{SHS}}$ ) . . . . .	114
3.5.3.3	Transfer Acknowledge ( $\overline{\text{TA}}$ ) . . . . .	115
3.5.3.4	Transfer Error Acknowledge ( $\overline{\text{TEA}}$ ) . . . . .	115
3.5.3.5	Emulation Mode Chip Selects (CSE[1:0]) . . . . .	115
3.5.3.6	Transfer Code (TC[2:0]) . . . . .	115
3.5.3.7	Read/Write ( $\overline{\text{R/W}}$ ) . . . . .	115

3.5.3.8	Address Bus ( $A[22:0]$ )	115
3.5.3.9	Enable Byte ( $\overline{EB}[3:0]$ )	116
3.5.3.10	Chip Select ( $CS[3:0]$ )	116
3.5.3.11	Output Enable ( $\overline{OE}$ )	116
3.5.4	Edge Port Signals	116
3.5.4.1	External Interrupts ( $\overline{INT}[7:6]$ )	116
3.5.4.2	External Interrupts ( $\overline{INT}[5:2]$ )	116
3.5.4.3	External Interrupts ( $\overline{INT}[1:0]$ )	116
3.5.5	Serial Peripheral Interface Module Signals	117
3.5.5.1	Master Out/Slave In (MOSI)	117
3.5.5.2	Master In/Slave Out (MISO)	117
3.5.5.3	Serial Clock (SCK)	117
3.5.5.4	Slave Select ( $\overline{SS}$ )	117
3.5.6	Serial Communications Interface Module Signals	117
3.5.6.1	Receive Data (RXD1 and RXD2)	117
3.5.6.2	Transmit Data (TXD1 and TXD2)	118
3.5.7	Timer Signals (ICOC1[3:0] and ICOC2[3:0])	118
3.5.8	Analog-to-Digital Converter Signals	118
3.5.8.1	Analog Inputs (PQA[4:3], PQA[1:0], and PQB[3:0])	118
3.5.8.2	Analog Reference ( $V_{RH}$ and $V_{RL}$ )	118
3.5.8.3	Analog Supply ( $V_{DDA}$ and $V_{SSA}$ )	118
3.5.8.4	Positive Supply ( $V_{DDH}$ )	118
3.5.9	Debug and Emulation Support Signals	119
3.5.9.1	Test Reset (TRST)	119
3.5.9.2	Test Clock (TCLK)	119
3.5.9.3	Test Mode Select (TMS)	119
3.5.9.4	Test Data Input (TDI)	119
3.5.9.5	Test Data Output (TDO)	119
3.5.9.6	Debug Event ( $\overline{DE}$ )	119
3.5.10	Test Signal (TEST)	120
3.5.11	Power and Ground Signals	120
3.5.11.1	Standby Power ( $V_{STBY}$ )	120
3.5.11.2	Positive Supply ( $V_{DD}$ )	120
3.5.11.3	Ground ( $V_{SS}$ )	120



## 3.2 Introduction

The MMC2114, MMC2113, and MMC2112 are available in three packages:

- 100-pin Joint-Electron Device Engineering Council (JEDEC) low-profile quad flat pack (LQFP) — The 100-pin device is a minimum pin set for single-chip mode implementation.
- 144-pin JEDEC LQFP — The 144-pin implementation includes 44 optional pins as a bond-out option to:
  - Accommodate an expanded set of features
  - Allow expansion of the number of general-purpose input/output (I/O)
  - Utilize off-chip memory
  - Provide enhanced support for development purposes
- 196-pin molded array process (MAP) ball grid array (BGA) — The 196-pin implementation includes:
  - Single-chip operation with extra general-purpose input/output
  - Expanded master mode for interfacing to external memories
  - Emulation mode for development and debug

The optional group of pins includes:

- 23 address output lines
- Four chip selects
- Two emulation chip selects
- Four byte/write enables
- Read/write ( $R/\overline{W}$ ) signal
- Output enable signal
- Three transfer code signals
- Six power/ground pins

**NOTE:** *The optional pins are either all present or none of them are present.*

### 3.3 Package Pinout Summary

Refer to:

- **Table 3-1** for a summary of the pinouts for the 144-pin and 100-pin LQFP packages.
- **Figure 3-1**, **Figure 3-2**, and **Figure 3-3** for a graphic view of the pinouts
- **Table 3-2** for a brief description of each signal

**Table 3-1. Package Pinouts (Sheet 1 of 5)**

Pin Number			Pin Name
144-Pin Package	100-Pin Package	196-Ball MAPBGA	
1	1	B1	D30 / PA6
2	2	C2	D29 / PA5
3	3	C1	D28 / PA4
4	4	D3	D27 / PA3
5	5	D2	D26 / PA2
6	—	D1	A11
7	6	E3	D25 / PA1
8	—	—	V <sub>SS</sub>
9	—	—	V <sub>DD</sub>
10	7	E2	D24 / PA0
11	—	E1	A10
12	8	F3	D23 / PB7
13	—	F2	A9
14	—	F1	A8
15	9	G3	D22 / PB6
16	10	G2	D21 / PB5
17	11	G1	D20 / PB4
18	12	—	V <sub>SS</sub>
19	13	—	V <sub>DD</sub>
20	14	H3	D19 / PB3
21	15	H2	D18 / PB2
22	16	H1	D17 / PB1
23	—	J3	A7

**Table 3-1. Package Pinouts (Sheet 2 of 5)**

Pin Number			Pin Name
144-Pin Package	100-Pin Package	196-Ball MAPBGA	
24	—	J2	A6
25	17	J1	D16 / PB0
26	—	K3	A5
27	18	K2	D15 / PC7
28	—	K1	A4
29	—	L3	A3
30	19	L2	D14 / PC6
31	20	L1	D13 / PC5
32	21	—	V <sub>SS</sub>
33	22	—	V <sub>DD</sub>
34	23	M2	D12 / PC4
35	24	M1	D11 / PC3
36	25	N1	D10 / PC2
37	26	P2	D9 / PC1
38	27	M3	D8 / PC0
39	28	N3	D7 / PD7
40	29	P3	D6 / PD6
41	30	M4	D5 / PD5
42	31	N4	D4 / PD4
43	32	P4	D3 / PD3
44	—	—	V <sub>SS</sub>
45	—	—	V <sub>DD</sub>
46	33	M5	D2 / PD2
47	—	N5	A2
48	34	P5	D1 / PD1
49	—	M6	A1
50	—	N6	A0
51	35	P6	D0 / PD0
52	36	M7	ICOC23
53	37	N7	ICOC22
54	38	P7	ICOC21
55	39	M8	ICOC20
56	40	N8	ICOC13

**Table 3-1. Package Pinouts (Sheet 3 of 5)**

Pin Number			Pin Name
144-Pin Package	100-Pin Package	196-Ball MAPBGA	
57	41	P8	ICOC12
58	42	M9	ICOC11
59	—	N9	R/W
60	—	P9	CSE1
61	43	M10	ICOC10
62	—	N10	CSE0
63	44	P10	TEST
64	—	—	V <sub>SS</sub>
65	—	—	V <sub>DD</sub>
66	45	M11	TXD2
67	—	N11	TC2
68	46	P11	RXD2
69	47	N12	TXD1
70	48	P12	RXD1
71	49	N13	INT0
72	50	P13	INT1
73	51	P14	V <sub>SSF</sub>
74	52	M12	V <sub>DDF</sub>
75	53	N14	INT2
76	54	—	V <sub>SS</sub>
77	55	—	V <sub>DD</sub>
78	—	M13	TC1
79	56	M14	INT3
80	—	L12	TC0
81	—	L13	CS3
82	57	L14	INT4
83	—	K12	CS2
84	58	K13	INT5
85	—	K14	CS1
86	—	J12	CS0
87	59	J13	No connect
88	60	J14	INT6
89	61	H12	INT7

**Table 3-1. Package Pinouts (Sheet 4 of 5)**

Pin Number			Pin Name
144-Pin Package	100-Pin Package	196-Ball MAPBGA	
90	62	H13	MOSI
91	63	H14	MISO
92	64	G12	V <sub>STBY</sub>
93	65	G13	SCK
94	66	G14	$\overline{SS}$
95	—	F12	$\overline{OE}$
96	—	F13	$\overline{EB3}$
97	67	F14	$\overline{SHS} / PE7$
98	—	E12	$\overline{EB2}$
99	68	E13	$\overline{TA} / PE6$
100	—	E14	$\overline{EB1}$
101	—	D12	$\overline{EB0}$
102	69	D13	$\overline{TEA} / PE5$
103	70	E11	V <sub>DDH</sub>
104	71	D14	PQB3
105	72	C12	PQB2
106	73	C13	PQB1
107	74	C14	PQB0
108	75	B14	PQA4
109	76	A13	PQA3
110	77	B12	PQA1
111	78	A12	PQA0
112	79	C11	V <sub>RL</sub>
113	80	B11	V <sub>RH</sub>
114	81	E10	V <sub>SSA</sub>
115	82	E9	V <sub>DDA</sub>
116	—	A11	A22
117	—	C10	A21
118	83	B10	$\overline{RESET}$
119	—	A10	A20
120	84	C9	$\overline{RSTOUT}$
121	—	B9	A19
122	—	A9	A18

**Table 3-1. Package Pinouts (Sheet 5 of 5)**

Pin Number			Pin Name
144-Pin Package	100-Pin Package	196-Ball MAPBGA	
123	85	D8	PLLEN
124	86	A8	XTAL
125	87	A7	EXTAL
126	88	—	V <sub>SS</sub>
127	89	—	V <sub>SS</sub>
128	90	E8	CLKOUT
129	91	—	V <sub>DD</sub>
130	92	B7	TCLK
131	—	A6	A17
132	—	B6	A16
133	93	A5	TDI
134	—	C6	A15
135	94	B5	TDO
136	—	A4	A14
137	—	C5	A13
138	95	B4	TMS
139	—	A3	A12
140	96	—	V <sub>SS</sub>
141	97	—	V <sub>DD</sub>
142	98	B3	$\overline{\text{TRST}}$
143	99	A2	$\overline{\text{DE}}$
144	100	C3	D31 / PA7
—	—	A1, B2, C4, C7, C8, D4–D7, E4–E7, F4–F6, G4, G5, H4, H5, J4, K4, –K11, L4–L11, N2, P1	V <sub>DD</sub>
—	—	A14, B8, B13, D9–D11, F7–F11, G6–G11, H6–H11, J5–J11	V <sub>SS</sub>

	1	2	3	4	5	6	7	8	9	10	11	12	13	14	
A	V <sub>DD</sub>	$\overline{DE}$	A12	A14	TDI	A17	EXTAL	XTAL	A18	A20	A22	POA0	POA3	V <sub>SS</sub>	A
B	D30	V <sub>DD</sub>	$\overline{TRST}$	TMS	TDO	A16	TCLK	V <sub>SS</sub>	A19	$\overline{RESET}$	V <sub>RH</sub>	POA1	V <sub>SS</sub>	POA4	B
C	D28	D29	D31	V <sub>DD</sub>	A13	A15	V <sub>DD</sub>	V <sub>DD</sub>	$\overline{RSTOUT}$	A21	V <sub>RL</sub>	PQB2	PQB1	PAB0	C
D	A11	D26	D27	V <sub>DD</sub>	V <sub>DD</sub>	V <sub>DD</sub>	V <sub>DD</sub>	PLLEN	V <sub>SS</sub>	V <sub>SS</sub>	V <sub>SS</sub>	$\overline{EB0}$	$\overline{TEA}$	PQB3	D
E	A10	D24	D25	V <sub>DD</sub>	V <sub>DD</sub>	V <sub>DD</sub>	V <sub>DD</sub>	CLKOUT	V <sub>DDA</sub>	V <sub>SSA</sub>	V <sub>DDH</sub>	$\overline{EB2}$	$\overline{TA}$	$\overline{EB1}$	E
F	A8	A9	D23	V <sub>DD</sub>	V <sub>DD</sub>	V <sub>DD</sub>	V <sub>SS</sub>	V <sub>SS</sub>	V <sub>SS</sub>	V <sub>SS</sub>	V <sub>SS</sub>	$\overline{OE}$	$\overline{EB3}$	$\overline{SHS}$	F
G	D20	D21	D22	V <sub>DD</sub>	V <sub>DD</sub>	V <sub>SS</sub>	V <sub>SS</sub>	V <sub>SS</sub>	V <sub>SS</sub>	V <sub>SS</sub>	V <sub>SS</sub>	V <sub>STBY</sub>	SCK	$\overline{SS}$	G
H	D17	D18	D19	V <sub>DD</sub>	V <sub>DD</sub>	V <sub>SS</sub>	V <sub>SS</sub>	V <sub>SS</sub>	V <sub>SS</sub>	V <sub>SS</sub>	V <sub>SS</sub>	$\overline{INT7}$	MOSI	MISO	H
J	D16	A6	A7	V <sub>DD</sub>	V <sub>SS</sub>	V <sub>SS</sub>	V <sub>SS</sub>	V <sub>SS</sub>	V <sub>SS</sub>	V <sub>SS</sub>	V <sub>SS</sub>	$\overline{CS0}$	N/C	$\overline{INT6}$	J
K	A4	D15	A5	V <sub>DD</sub>	V <sub>DD</sub>	V <sub>DD</sub>	V <sub>DD</sub>	V <sub>DD</sub>	V <sub>DD</sub>	V <sub>DD</sub>	V <sub>DD</sub>	$\overline{CS2}$	$\overline{INT5}$	$\overline{CS1}$	K
L	D13	D14	A3	V <sub>DD</sub>	V <sub>DD</sub>	V <sub>DD</sub>	V <sub>DD</sub>	V <sub>DD</sub>	V <sub>DD</sub>	V <sub>DD</sub>	V <sub>DD</sub>	TC0	CS3	$\overline{INT4}$	L
M	D11	D12	D8	D5	D2	A1	ICOC23	ICOC20	ICOC11	ICOC10	TXD2	V <sub>DDF</sub>	TC1	$\overline{INT3}$	M
N	D10	V <sub>DD</sub>	D7	D4	A2	A0	ICOC22	ICOC13	R/ $\overline{W}$	CSE0	TC2	TXD1	$\overline{INT0}$	$\overline{INT2}$	N
P	V <sub>DD</sub>	D9	D6	D3	D1	D0	ICOC21	ICOC12	CSE1	TEST	RXD2	RXD1	$\overline{INT1}$	V <sub>SS</sub>	P
	1	2	3	4	5	6	7	8	9	10	11	12	13	14	

**Figure 3-1. 196-Ball MAPBGA Assignments**

Signal Description

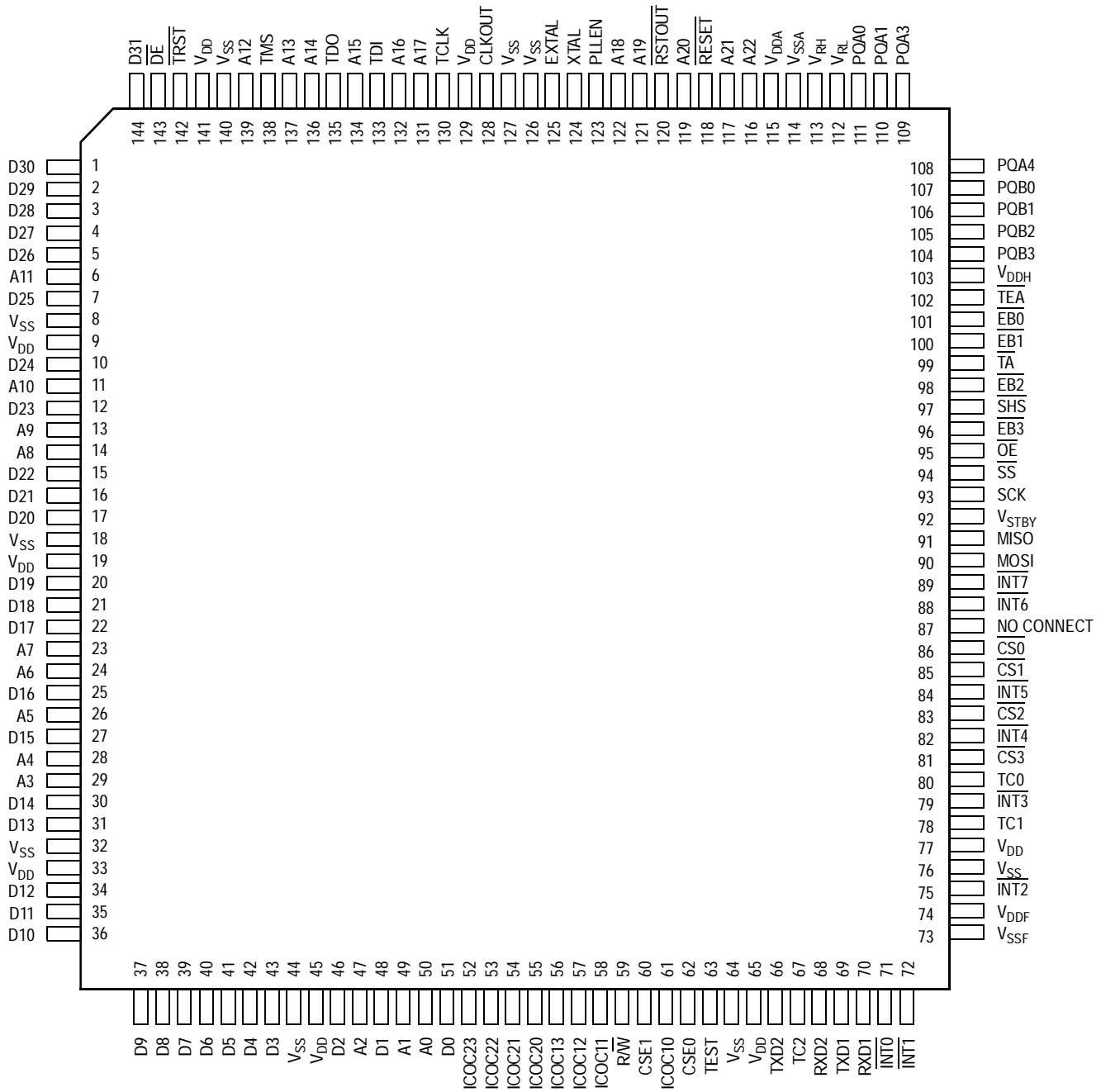

Figure 3-2. 144-Pin LQFP Assignments



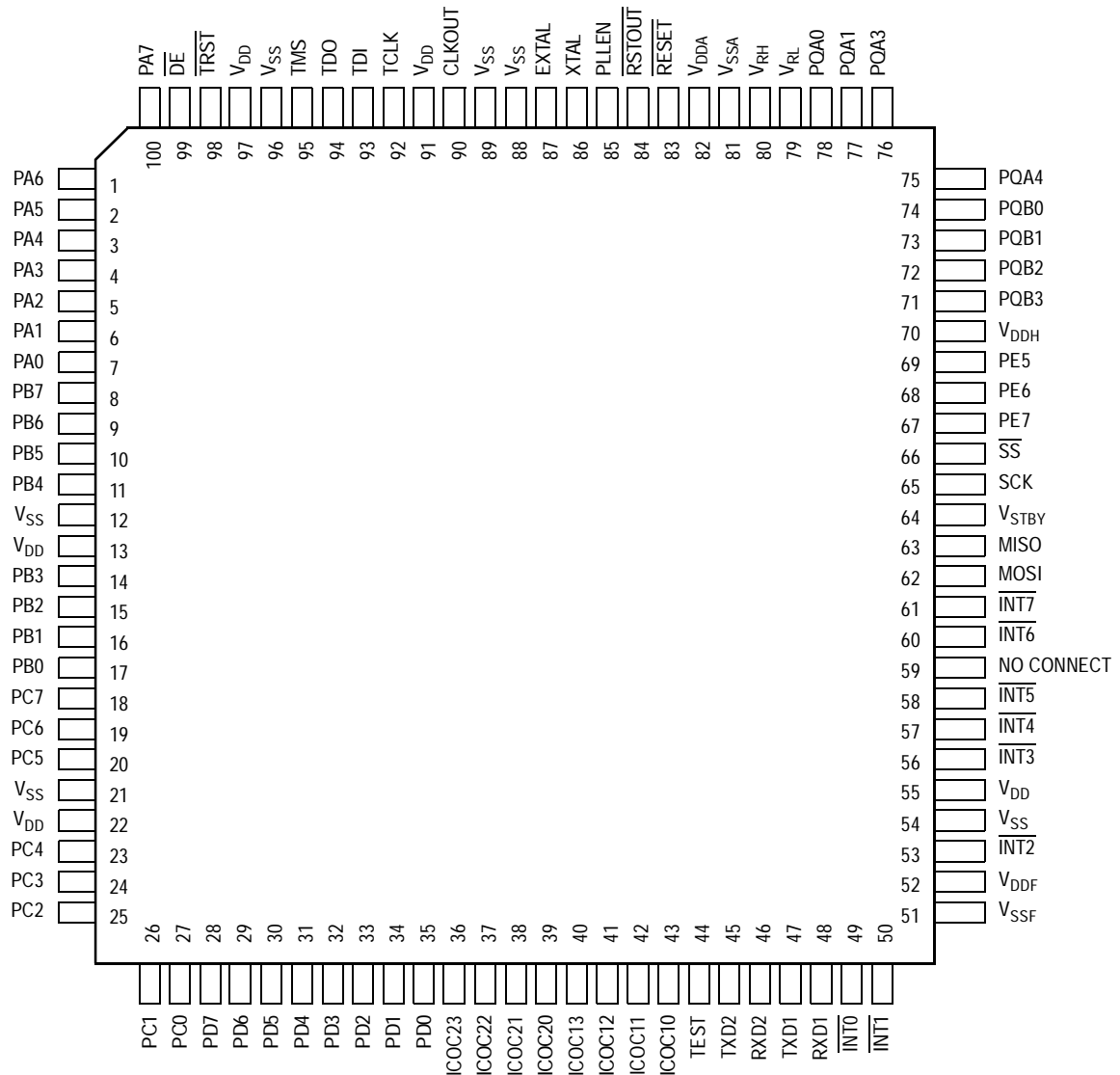

Figure 3-3. 100-Pin LQFP Assignments

**Signal Description**
**Table 3-2. Signal Descriptions (Sheet 1 of 3)**

Name <sup>(1)</sup>	Alternate	Qty.	Dir.	Input Hyst.	Input Sync. <sup>(2)</sup>	Drive Strength Control <sup>(3)</sup>	Pullup <sup>(4)</sup>	Output Driver (ST/OD/SP) <sup>(5)</sup>
<b>Reset</b>								
$\overline{\text{RESET}}$	—	1	I/O <sup>(6)</sup>	Y	Y	—	Pullup	—
$\overline{\text{RSTOUT}}$	$\overline{\text{SHOWINT}}$	1	I/O <sup>(6)</sup>	—	—	LOAD	—	ST
<b>Clock</b>								
EXTAL	—	1	I	N	N	—	—	SP
XTAL	—	1	O	—	—	—	—	SP
CLKOUT	—	1	I/O <sup>(6)</sup>	—	—	LOAD	—	ST
PLLEN	—	1	I	—	—	—	Pullup	—
<b>External Memory Interface and Ports</b>								
D[31:0]	PA[7:0], PB[7:0] PC[7:0], PD[7:0]	32	I/O	Y	Y	LOAD	—	ST
$\overline{\text{SHS}}$	$\overline{\text{RCON}} / \text{PE7}$	1	I/O	Y	Y	LOAD	Pullup	ST
$\overline{\text{TA}}$	PE6	1	I/O	Y	Y	LOAD	Pullup	ST
TEA	PE5	1	I/O	Y	Y	LOAD	Pullup	ST
CSE[1:0]	PE[4:3]	2	I/O	Y	Y	LOAD	Pullup	ST
TC[2:0]	PE[2:0]	3	I/O	Y	Y	LOAD	Pullup	ST
$\overline{\text{R/W}}$	PF7	1	I/O	Y	Y	LOAD	Pullup	ST
A[22:0]	PF[6:0], PG[7:0] PH[7:0]	23	I/O	Y	Y	LOAD	Pullup	ST
$\overline{\text{EB}}[3:0]$	PI[7:4]	4	I/O	Y	Y	LOAD	Pullup	ST
$\overline{\text{CS}}[3:0]$	PI[3:0]	4	I/O	Y	Y	LOAD	Pullup	ST
$\overline{\text{OE}}$	—	1	I/O <sup>(6)</sup>	—	—	LOAD	—	ST
<b>Edge Port</b>								
$\overline{\text{INT}}[7:6]$	TSIZ[1:0] / GPIO	2	I/O	Y	Y	LOAD	—	—
$\overline{\text{INT}}[5:2]$	PSTAT[3:0] / GPIO	4	I/O	Y	Y	LOAD	—	—
$\overline{\text{INT}}[1:0]$	GPIO	2	I/O	Y	Y	LOAD	—	—

**Table 3-2. Signal Descriptions (Sheet 2 of 3)**

Name <sup>(1)</sup>	Alternate	Qty.	Dir.	Input Hyst.	Input Sync. <sup>(2)</sup>	Drive Strength Control <sup>(3)</sup>	Pullup <sup>(4)</sup>	Output Driver (ST/OD/SP) <sup>(5)</sup>
<b>Serial Peripheral Interface (SPI)</b>								
MOSI	GPIO	1	I/O	Y	Y	RDPSP0	Pullup <sup>(4)</sup>	ST / OD <sup>(7)</sup>
MISO	GPIO	1	I/O	Y	Y	RDPSP0	Pullup <sup>(4)</sup>	ST / OD <sup>(7)</sup>
SCK	GPIO	1	I/O	Y	Y	RDPSP0	Pullup <sup>(4)</sup>	ST / OD <sup>(7)</sup>
$\overline{SS}$	GPIO	1	I/O	Y	Y	RDPSP0	Pullup <sup>(4)</sup>	ST / OD <sup>(7)</sup>
<b>Serial Communication Interface (SCI1 and SCI2)</b>								
TXD1	GPIO	1	I/O	Y	Y	RDPSCI0	Pullup <sup>(4)</sup>	ST / OD <sup>(7)</sup>
RXD1	GPIO	1	I/O	Y	Y	RDPSCI0	Pullup <sup>(4)</sup>	ST / OD <sup>(7)</sup>
TXD2	GPIO	1	I/O	Y	Y	RDPSCI0	Pullup <sup>(4)</sup>	ST / OD <sup>(7)</sup>
RXD2	GPIO	1	I/O	Y	Y	RDPSCI0	Pullup <sup>(4)</sup>	ST / OD <sup>(7)</sup>
<b>Timer 1 and Timer 2</b>								
ICOC13	IC / OC / PAI / GPIO	1	I/O	Y	Y	RDPT	Pullup <sup>(4)</sup>	ST
ICOC1[2:0]	IC / OC / GPIO	3	I/O	Y	Y	RDPT	Pullup <sup>(4)</sup>	ST
ICOC23	IC / OC / PAI / GPIO	1	I/O	Y	Y	RDPT	Pullup <sup>(4)</sup>	ST
ICOC2[2:0]	IC / OC / GPIO	3	I/O	Y	Y	RDPT	Pullup <sup>(4)</sup>	ST
<b>Queued Analog-to-Digital Converter (QADC)</b>								
PQA4–PQA3, PQA1–PQA0	GPIO	4	I/O	Y	Y	—	—	ST
PQB[3:0]	GPI	4	I/O	Y	Y	—	—	ST
V <sub>RH</sub>	—	1	I	—	—	—	—	—
V <sub>RL</sub>	—	1	I	—	—	—	—	—
V <sub>DDA</sub>	—	1	I	—	—	—	—	—
V <sub>SSA</sub>	—	1	I	—	—	—	—	—
V <sub>DDH</sub>	—	1	I	—	—	—	—	—

**Signal Description**
**Table 3-2. Signal Descriptions (Sheet 3 of 3)**

Name <sup>(1)</sup>	Alternate	Qty.	Dir.	Input Hyst.	Input Sync. <sup>(2)</sup>	Drive Strength Control <sup>(3)</sup>	Pullup <sup>(4)</sup>	Output Driver (ST/OD/SP) <sup>(5)</sup>
<b>Debug and JTAG Test Port Control</b>								
$\overline{\text{TRST}}$	—	1	I	Y	N	—	Pullup	—
TCLK	—	1	I	Y	N	—	Pullup	—
TMS	—	1	I	Y	N	—	Pullup	—
TDI	—	1	I	Y	N	—	Pullup	—
TDO	—	1	O <sup>(8)</sup>	—	—	LOAD	—	ST
DE	—	1	I/O	Y	N	LOAD	Pullup	OD
<b>Test</b>								
TEST	—	1	I	Y	N	—	—	—
<b>Power Supplies</b>								
V <sub>DDF</sub>	—	1	I	—	—	—	—	—
V <sub>SSF</sub>	—	1	I	—	—	—	—	—
V <sub>STBY</sub>	—	1	I	—	—	—	—	—
V <sub>DD</sub>	—	5	I	—	—	—	—	—
V <sub>SS</sub>	—	6	I	—	—	—	—	—
V <sub>DD</sub>	—	3	I	—	—	—	—	—
V <sub>SS</sub>	—	3	I	—	—	—	—	—
Total		100						
Total with optional pins		144						

1. Shaded signals are for optional bond-out for 144-pin package.
2. Synchronized input used only if signal configured as a digital I/O.  $\overline{\text{RESET}}$  signal is always synchronized, except in low-power stop mode.
3. LOAD (Chip Configuration Register bit), RDPSP0 (PURD register bit in SPI), RDPSCI0 (SCIPURD register bit in both SCIs), RDPT (TIMSCR2 register bit in both timers)
4. All pullups are disconnected when the signal is programmed as an output.
5. Output driver type: ST = standard, OD = standard driver with open-drain pulldown option selected, SP = special
6. Digital input function for RSTOUT, CLKOUT, OE, and digital output function for RESET used only for JTAG boundary scan
7. Open-drain and pullup function selectable via programmer's model in module configuration registers
8. Three-state output with no input function

### 3.4 Chip Specific Implementation Signal Issues

Most modules are designed to allow expanded capabilities if all the module signals to the pads are implemented. This subsection discusses how these modules are implemented on the MMC2114, MMC2113, and MMC2112.

#### 3.4.1 $\overline{\text{RSTOUT}}$ Signal Functions

The  $\overline{\text{RSTOUT}}$  signal has these multiple functions:

- Whenever the internal system reset is asserted, the  $\overline{\text{RSTOUT}}$  signal will always be asserted to indicate the reset condition to the system.
- If the internal reset is not asserted, then setting the  $\overline{\text{FRCRSTOUT}}$  bit in the Reset Control Register (RCR) will assert the  $\overline{\text{RSTOUT}}$  signal for as long as the  $\overline{\text{FRCRSTOUT}}$  bit is set. See [5.6.1 Reset Control Register](#).
- If the internal reset is not asserted and the  $\overline{\text{FRCRSTOUT}}$  bit is not set, then setting the  $\overline{\text{SHOWINT}}$  bit in the Chip Configuration Register will reflect internal interrupt requests out to the  $\overline{\text{RSTOUT}}$  signal.
- If the internal reset is not asserted and the  $\overline{\text{FRCRSTOUT}}$  bit is not set and the  $\overline{\text{SHOWINT}}$  bit is not set, then the  $\overline{\text{RSTOUT}}$  signal will be negated to indicate to the system that there is no reset condition.

**CAUTION:** *External logic used to drive reset configuration data during reset needs to be considered when using the  $\overline{\text{RSTOUT}}$  signal for a function other than an indication of reset.*

### 3.4.2 $\overline{\text{INT}}$ Signal Functions

The  $\overline{\text{INT}}$  signals have these multiple functions:

- If the  $\text{SZEN}$  bit in the Chip Configuration Register is set, then  $\overline{\text{INT}}[7:6]$  will be used to reflect the state of the  $\text{TSIZ}[1:0]$  signals from the CPU. See [4.7.3.1 Chip Configuration Register](#).
- If the  $\text{PSTEN}$  bit in the Chip Configuration Register (CCR) is set, then  $\overline{\text{INT}}[5:2]$  will be used to reflect the state of the  $\text{PSTAT}[3:0]$  signals from the CPU. See [4.7.3.1 Chip Configuration Register](#).

**NOTE:** *If the  $\text{SZEN}$  or  $\text{PSTEN}$  bits are set during emulation mode, then the corresponding edge port  $\overline{\text{INT}}$  functions are lost and will not be emulated externally.*

The default reset value for the  $\text{PUPSC1}$  bit in  $\text{SCIPURD}$  is 0. Thus, the pullup function is disabled by default.

### 3.4.3 Serial Peripheral Interface (SPI) Pin Functions

The SPI module can support up to eight external pins, but only the four pins required for the SPI interface are implemented.

Full SPI interface capabilities and GPIO functions using the  $\text{MISO}$ ,  $\text{MOSI}$ ,  $\text{SCK}$ , and  $\overline{\text{SS}}$  pins are supported.

- $\text{SWOM}$  register bit controls whether output buffers behave as open-drain outputs. Default is not open-drain outputs.
- $\text{PUPSP0}$  register bit enables internal weak pad pullup devices. Default is pullups disabled.
- $\text{RDPSP0}$  register bit controls reduced drive function of output buffers. Default is full drive.

GPIO [7:4] of SPI module not implemented.

- Writes to bits [7:4] of the SPIPORT and SPIDDR registers have no effect except to change the register bit values.
- Reads of bits [7:4] of the SPIPORT when the corresponding SPIDDR bits are set for inputs always return 0.
- PUPSP and RDPSP register bits have no effect.

The default reset values for the PUPSP bit in SPIPURD is 0. Thus, the pullup function is disabled by default.

### 3.4.4 Serial Communications Interface (SCI1 and SCI2) Pin Functions

Full SCI interface capabilities and GPIO functions using the TXD1/2 and RXD1/2 pins are supported.

- WOMS register bit controls whether output buffers behave as open-drain outputs. Default is not open-drain outputs.
- PUPSCI register bit enables internal weak pad pullup devices. Default is pullups disabled.
- RDPSCI register bit controls reduced drive function of output buffers. Default is full drive.

GPIO [7:2] of SCI modules not implemented.

- Writes to bits [7:2] of the SCIPORT and SCIDDR registers have no effect except to change the register bit values.
- Reads of bits [7:2] of the SCIPORT when the corresponding SCIDDR bits are set for inputs always return 0.
- PUPSCI and RDPSCI register bits have no effect.

The default reset value for PUPSCI is 0. Thus, the pullup function is disabled by default.

**NOTE:** *Only the pins associated with each SCI are controlled by the register bits for the corresponding SCI. Thus, the WOMS register bit from SCI1 only affects TXD1 and RXD1 and has no effect on TXD2 and RXD2.*

### 3.4.5 Timer 1 and Timer 2 Pin Functions

The timer modules can support up to four external pins each.

**NOTE:** *Only the pins associated with each timer are controlled by the register bits for the corresponding timer.*

Full timer port pin functions are supported.

- PUPT register bit enables internal weak pad pullup devices. Default disables pullups.
- RDPT register bit controls reduced drive function of output buffers. Default is full drive.

The default reset value for PUPT is 0. Thus, the pullup function is disabled by default.

The sync input is tied off and this function is not supported.

### 3.4.6 Queued Analog-to-Digital Converter (QADC) Pin Functions

This implementation is a limited pin out version of the original QADC. Limiting the number of pins lowers the over all pin count of the complete package. The lower pin count is achieved by utilizing 8 of 16 pins of the original full pin set. The available pins are, PQA4–PQA3, PQA1–PQA0, and PQB3–PQB0. All of the original functionality of the module is implemented with exception of limiting the total number of multiplexed channels. By using four external multiplexer chips, the maximum number of channels is 18. In nonmultiplexed mode, the maximum number of channels is eight.



## 3.5 Signal Descriptions

This subsection provides a brief description of the signals. For more detailed information, reference the specific module section.

### 3.5.1 Reset Signals

These signals are used to either reset the chip or as a reset indication.

#### 3.5.1.1 Reset In ( $\overline{RESET}$ )

This active-low input signal is used as the external reset request. Reset places the CPU in supervisor mode with default settings for all register bits.

#### 3.5.1.2 Reset Out ( $\overline{RSTOUT}$ )

This active-low output signal is an indication that the internal reset controller has reset the chip. When  $\overline{RSTOUT}$  is active, the user may drive override configuration options on the data bus. See [Table 4-7. Configuration During Reset](#).  $\overline{RSTOUT}$  is three-stated in phase-lock loop (PLL) test mode.

$\overline{RSTOUT}$  may also be used to reflect an indication of an internal interrupt request.

### 3.5.2 Phase-Lock Loop (PLL) and Clock Signals

These signals are used to support the on-chip clock generation circuitry.

#### 3.5.2.1 External Clock In ( $EXTAL$ )

This input signal is always driven by an external clock input except when used as a connection to an external crystal when the internal oscillator circuit is used. The clock source is configured during reset.

## Signal Description

### 3.5.2.2 Crystal (XTAL)

This output signal is used as a connection to drive an external crystal when the internal oscillator circuit is used. XTAL should be grounded when using an external clock input on EXTAL.

### 3.5.2.3 Clock Out (CLKOUT)

This output signal reflects the internal system clock.

### 3.5.2.4 PLL Enable (PLLEN)

This is an active high signal only required during reset if chip configuration is performed. If this signal is pulled high during reset, then the PLL will be used to clock the device. Pulling this signal low during reset selects external clock mode. See [Table 4-7. Configuration During Reset](#).

## 3.5.3 External Memory Interface Signals

In addition to the functions stated here, these signals can also be configured for discrete I/O.

### 3.5.3.1 Data Bus (D[31:0])

These three-state bidirectional signals provide the general-purpose data path between the microcontroller unit (MCU) and all other devices. Some of these pins are used during reset for chip configuration.

### 3.5.3.2 Show Cycle Strobe ( $\overline{SHS}$ )

This output signal is used in emulation mode as a strobe for capturing addresses, controls, and data during show cycles. This signal is also used as  $\overline{RCON}$ .

**NOTE:** The  $\overline{RCON}$  signal, used only during reset, indicates whether the states on the external signals affect the chip configuration.

### 3.5.3.3 Transfer Acknowledge ( $\overline{TA}$ )

This input signal indicates that the external data transfer is complete. During a read cycle, when the processor recognizes  $\overline{TA}$ , it latches the data and then terminates the bus cycle. During a write cycle, when the processor recognizes  $\overline{TA}$ , the bus cycle is terminated. This signal is an input in master and emulation modes. This function is not used in single-chip mode and its pin defaults to digital I/O.

### 3.5.3.4 Transfer Error Acknowledge ( $\overline{TEA}$ )

This signal indicates an error condition exists for the bus transfer. The bus cycle is terminated and the central processor unit (CPU) begins execution of the access error exception. This signal is an input in master and emulation modes. This function is not used in single-chip mode and its pin defaults to digital I/O.

### 3.5.3.5 Emulation Mode Chip Selects ( $CSE[1:0]$ )

These output signals provide chip select support in emulation mode.

### 3.5.3.6 Transfer Code ( $TC[2:0]$ )

These output signals indicate the data transfer code for the current bus cycle. These signals are enabled by default only in emulation mode. See [Table 12-2. PEPAR Reset Values](#).

### 3.5.3.7 Read/Write ( $R/\overline{W}$ )

This output signal indicates the direction of the data transfer on the bus. A logic 1 indicates a read from a slave device and a logic 0 indicates a write to a slave device.

### 3.5.3.8 Address Bus ( $A[22:0]$ )

These output signals provide the address for the current bus transfer.

**Signal Description**
**3.5.3.9 Enable Byte ( $\overline{EB[3:0]}$ )**

These output signals indicate which byte of data is valid during external cycles.

**3.5.3.10 Chip Select ( $\overline{CS[3:0]}$ )**

These output signals select external devices for external bus transactions.

**3.5.3.11 Output Enable ( $\overline{OE}$ )**

This output signal indicates when an external device can drive data during external read cycles.

**3.5.4 Edge Port Signals**

These signals are used by the edge port module.

**3.5.4.1 External Interrupts ( $\overline{INT[7:6]}$ )**

These bidirectional signals function as either external interrupt sources or GPIO. Also, these signals may be used to reflect the internal TSIZ[1:0] signals and externally to provide an indication of the CPU transfer size. See [4.7.3.1 Chip Configuration Register](#) and [Section 20. External Bus Interface Module \(EBI\)](#).

**3.5.4.2 External Interrupts ( $\overline{INT[5:2]}$ )**

These bidirectional signals function as either external interrupt sources or GPIO. Also, these signals may be used to reflect the internal PSTAT[3:0] signals and externally to provide an indication of the CPU processor status. See [4.7.3.1 Chip Configuration Register](#) and [Section 20. External Bus Interface Module \(EBI\)](#).

**3.5.4.3 External Interrupts ( $\overline{INT[1:0]}$ )**

These bidirectional signals function as either external interrupt sources or GPIO.

### 3.5.5 Serial Peripheral Interface Module Signals

These signals are used by the SPI module and may also be configured to be discrete I/O signals.

#### 3.5.5.1 Master Out/Slave In (MOSI)

This signal is the serial data output from the SPI in master mode and the serial data input in slave mode.

#### 3.5.5.2 Master In/Slave Out (MISO)

This signal is the serial data input to the SPI in master mode and the serial data output in slave mode.

#### 3.5.5.3 Serial Clock (SCK)

The serial clock synchronizes data transmissions between master and slave devices. SCK is an output if the SPI is configured as a master. SCK is an input if the SPI is configured as a slave.

#### 3.5.5.4 Slave Select ( $\overline{SS}$ )

This I/O signal is the peripheral chip select signal in master mode and is an active-low slave select in slave mode.

### 3.5.6 Serial Communications Interface Module Signals

These signals are used by the two SCI modules.

#### 3.5.6.1 Receive Data (RXD1 and RXD2)

These signals are used for the SCI receiver data input and are also available for GPIO when not configured for receiver operation.

## Signal Description

### 3.5.6.2 Transmit Data (TXD1 and TXD2)

These signals are used for the SCI transmitter data output and are also available for GPIO when not configured for transmitter operation.

### 3.5.7 Timer Signals (ICOC1[3:0] and ICOC2[3:0])

These signals provide the external interface to the timer functions. They may be configured as general-purpose I/O if the timer output function is not needed. The default state at reset is general-purpose input.

### 3.5.8 Analog-to-Digital Converter Signals

These signals are used by the analog-to-digital converter (QADC) module.

#### 3.5.8.1 Analog Inputs (PQA[4:3], PQA[1:0], and PQB[3:0])

These signals provide the analog inputs to the QADC. The PQA and PQB signals may also be used as general-purpose digital I/O.

#### 3.5.8.2 Analog Reference ( $V_{RH}$ and $V_{RL}$ )

These signals serve as the high ( $V_{RH}$ ) and low ( $V_{RL}$ ) reference potentials for the analog converter.

#### 3.5.8.3 Analog Supply ( $V_{DDA}$ and $V_{SSA}$ )

These dedicated power supply signals isolate the sensitive analog circuitry from the normal levels of noise present on the digital power supply.

#### 3.5.8.4 Positive Supply ( $V_{DDH}$ )

This signal supplies positive power to the ESD structures in the QADC pads.

### 3.5.9 Debug and Emulation Support Signals

These signals are used as the interface to the on-chip JTAG (Joint Test Action Group) controller and also to interface to the OnCE logic.

#### 3.5.9.1 Test Reset ( $\overline{TRST}$ )

This active-low input signal is used to initialize the JTAG and OnCE logic asynchronously.

#### 3.5.9.2 Test Clock (TCLK)

This input signal is the test clock used to synchronize the JTAG and OnCE logic.

#### 3.5.9.3 Test Mode Select (TMS)

This input signal is used to sequence the JTAG state machine. TMS is sampled on the rising edge of TCLK.

#### 3.5.9.4 Test Data Input (TDI)

This input signal is the serial input for test instructions and data. TDI is sampled on the rising edge of TCLK.

#### 3.5.9.5 Test Data Output (TDO)

This output signal is the serial output for test instructions and data. TDO is three-stateable and is actively driven in the shift-IR and shift-DR controller states. TDO changes on the falling edge of TCLK.

#### 3.5.9.6 Debug Event ( $\overline{DE}$ )

This is a bidirectional, active-low signal. As an output, this signal will be asserted for three system clocks, synchronous to the rising CLKOUT edge, to acknowledge that the CPU has entered debug mode as a result of a debug request or a breakpoint condition. As an input, this signal provides multiple functions.

## Signal Description

### 3.5.10 Test Signal (TEST)

This input signal (TEST) is reserved for factory testing only and should be connected to  $V_{SS}$  to prevent unintentional activation of test functions.

### 3.5.11 Power and Ground Signals

These signals provide system power and ground to the chip. Multiple signals are provided for adequate current capability. All power supply signals must have adequate bypass capacitance for high-frequency noise suppression.

#### 3.5.11.1 Standby Power ( $V_{STBY}$ )

This signal is used to provide standby voltage to the RAM array if  $V_{DD}$  is lost. Typically, if used, this signal would be connected to a battery.

#### 3.5.11.2 Positive Supply ( $V_{DD}$ )

This signal supplies positive power to the core logic and I/O pads.

#### 3.5.11.3 Ground ( $V_{SS}$ )

This signal is the negative supply (ground) to the chip.



## Section 4. Chip Configuration Module (CCM)

### 4.1 Contents

4.2	Introduction . . . . .	122
4.3	Features . . . . .	122
4.4	Modes of Operation . . . . .	122
4.4.1	Master Mode . . . . .	123
4.4.2	Single-Chip Mode . . . . .	123
4.4.3	Emulation Mode . . . . .	123
4.4.4	Factory Access Slave Test (FAST) Mode . . . . .	123
4.5	Block Diagram . . . . .	124
4.6	Signal Descriptions . . . . .	124
4.7	Memory Map and Registers . . . . .	125
4.7.1	Programming Model . . . . .	125
4.7.2	Memory Map . . . . .	126
4.7.3	Register Descriptions . . . . .	126
4.7.3.1	Chip Configuration Register . . . . .	126
4.7.3.2	Reset Configuration Register . . . . .	129
4.7.3.3	Chip Identification Register . . . . .	131
4.7.3.4	Chip Test Register . . . . .	132
4.8	Functional Description . . . . .	133
4.8.1	Reset Configuration . . . . .	133
4.8.2	Chip Mode Selection . . . . .	135
4.8.3	Boot Device Selection . . . . .	135
4.8.4	Output Pad Strength Configuration . . . . .	137
4.8.5	Clock Mode Selection . . . . .	137
4.8.6	Internal FLASH Configuration . . . . .	138
4.9	Reset . . . . .	138
4.10	Interrupts . . . . .	138

## Chip Configuration Module (CCM)

### 4.2 Introduction

The chip configuration module (CCM) controls the chip configuration and mode of operation.

### 4.3 Features

The CCM performs these operations.

- Selects the chip operating mode:
  - Master mode
  - Single-chip mode
  - Emulation mode
  - Factory access slave test (FAST) mode for factory test only
- Selects external clock or phase-lock loop (PLL) mode with internal or external reference
- Selects output pad strength
- Selects boot device
- Selects module configuration
- Selects bus monitor configuration

### 4.4 Modes of Operation

The CCM configures the chip for four modes of operation:

- Master mode
- Single-chip mode
- Emulation mode
- FAST mode for factory test only

The operating mode is determined at reset and cannot be changed thereafter.

#### 4.4.1 Master Mode

In master mode, the internal central processor unit (CPU) can access external memories and peripherals. Full master mode functionality requires the bonding out of the optional pins. The external bus consists of a 32-bit data bus and 23 address lines. Available bus control signals include  $\overline{R/W}$ ,  $TC[2:0]$ ,  $TSIZ[1:0]$ ,  $\overline{TA}$ ,  $\overline{TEA}$ ,  $\overline{OE}$ , and  $\overline{EB}[3:0]$ . Up to four chip selects can be programmed to select and control external devices and to provide bus cycle termination. When interfacing to 16-bit ports, the ports C and D pins and  $\overline{EB}[3:2]$  can be configured as general-purpose input/output (I/O).

#### 4.4.2 Single-Chip Mode

In single-chip mode, all memory is internal to the chip. External bus pins are configured as digital I/O.

#### 4.4.3 Emulation Mode

Emulation mode supports external port replacement logic. All ports are emulated and all primary pin functions are enabled. Since the full external bus must be visible to support the external port replacement logic, the emulation mode pin configuration resembles master mode. Full emulation mode functionality requires bonding out the optional pins. Emulation mode chip selects are provided to give additional information about the bus cycle. Also, the signal  $\overline{SHS}$  is provided as a strobe for capturing addresses and data during show cycles.

#### 4.4.4 Factory Access Slave Test (FAST) Mode

FAST mode is for factory test only.

Chip Configuration Module (CCM)

4.5 Block Diagram

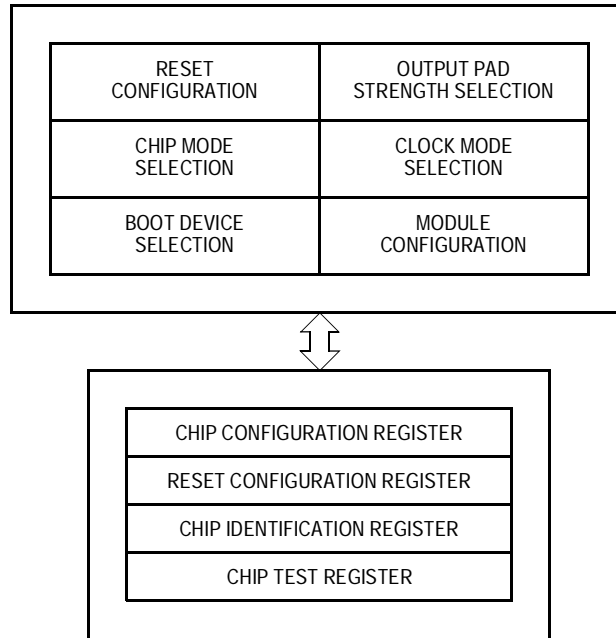

Figure 4-1. Chip Configuration Module Block Diagram

4.6 Signal Descriptions

Table 4-1 provides an overview of the CCM signals. For more detailed information, refer to Section 3. Signal Description.

Table 4-1. Signal Properties

Name	Function	Reset State
$\overline{\text{RCON}}$	Reset configuration select	Internal weak pullup device
PLLEN	Clock mode select	—
D[26, 23, 22, 21, 19, 18, 17, 16]	Reset configuration overrides	—

## 4.7 Memory Map and Registers

This subsection provides a description of the memory map and registers.

### 4.7.1 Programming Model

The CCM programming model consists of these registers:

- The Chip Configuration Register (CCR) controls the main chip configuration. See [4.7.3.1 Chip Configuration Register](#).
- The Reset Configuration Register (RCON) indicates the default chip configuration. See [4.7.3.2 Reset Configuration Register](#).
- The Chip Identification Register (CIR) contains a unique part number. See [4.7.3.3 Chip Identification Register](#).
- The Chip Test Register (CTR) contains chip-specific test functions. See [4.7.3.4 Chip Test Register](#).

Some control register bits are implemented as write-once bits. These bits are always readable, but once the bit has been written, additional writes have no effect, except during debug and test operations.

Some write-once bits and test bits can be read and written while in debug mode or test mode. When debug or test mode is exited, the chip configuration module resumes operation based on the current register values. If a write to a write-once register bit occurs while in debug or test mode, the register bit remains writable on exit from debug or test mode. [Table 4-2](#) shows the accessibility of write-once bits.

**Table 4-2. Write-Once Bits Read/Write Accessibility**

Configuration	Read/Write Access
All configurations	Read-always
Debug operation (all modes)	Write-always
Test operation (all modes)	Write-always
Master mode	Write-once
Single-chip mode	Write-once
FAST mode	Write-once
Emulation mode	Write-once

Chip Configuration Module (CCM)

4.7.2 Memory Map

Table 4-3. Chip Configuration Module Memory Map

Address	Bits 31–16	Bits 15–0	Access <sup>(1)</sup>
0x00c1_0000	Chip Configuration Register (CCR)	Reserved <sup>(2)</sup>	S
0x00c1_0004	Reset Configuration Register (RCON)	Chip Identification Register (CIR)	S
0x00c1_0008	Chip Test Register (CTR)	Reserved <sup>(2)</sup>	S
0x00c1_000c	Unimplemented <sup>(3)</sup>		—

1. S = CPU supervisor mode access only. User mode accesses to supervisor only addresses have no effect and result in a cycle termination transfer error.
2. Writing to reserved addresses has no effect; reading returns 0s.
3. Accessing an unimplemented address has no effect and causes a cycle termination transfer error.

4.7.3 Register Descriptions

The following subsection describes the CCM registers.

4.7.3.1 Chip Configuration Register

Address: 0x00c1\_0000 and 0x00c1\_0001

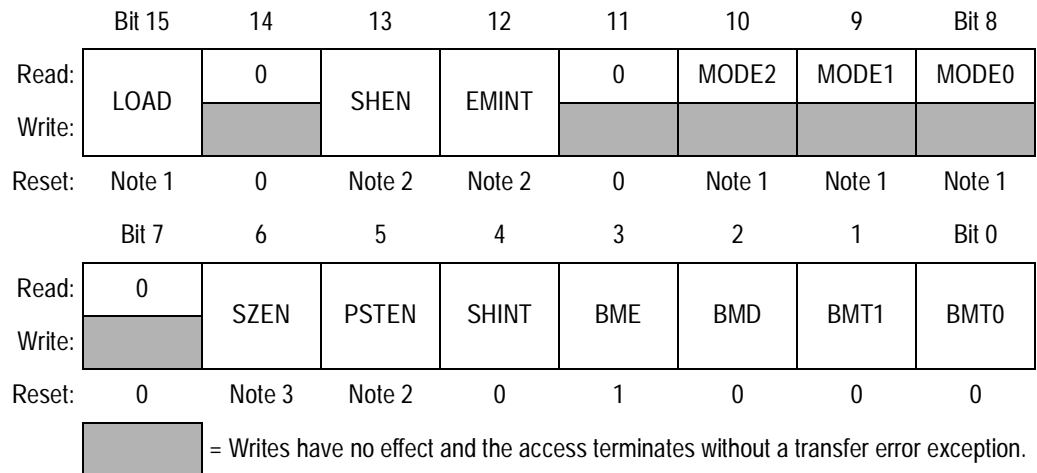

Notes:

1. Determined during reset configuration
2. 0 for all configurations except emulation mode, 1 for emulation mode
3. 0 for all configurations except emulation and master modes, 1 for emulation and master modes

Figure 4-2. Chip Configuration Register (CCR)

**LOAD** — Pad Driver Load Bit

The LOAD bit selects full or default drive strength for selected pad output drivers. For maximum capacitive load, set the LOAD bit to select full drive strength. For reduced power consumption, clear the LOAD bit to select default drive strength.

- 1 = Full drive strength
- 0 = Default drive strength

**Table 4-2** shows the read/write accessibility of this write-once bit.

**SHEN** — Show Cycle Enable Bit

The SHEN bit enables the external memory interface to drive the external bus during internal transfer operations.

- 1 = Show cycles enabled
- 0 = Show cycles disabled

In emulation mode, the SHEN bit is read-only. In all other modes, it is a read/write bit.

**EMINT** — Emulate Internal Address Space Bit

The EMINT bit enables chip select 1 (CS1) to decode the internal memory address space.

- 1 = CS1 decodes internal memory address space.
- 0 = CS1 decodes external memory address space.

The EMINT bit is read-always but can be written only in emulation mode.

**MODE[2:0]** — Chip Configuration Mode Field

This read-only field reflects the chip configuration mode, as shown in **Table 4-4**.

**Table 4-4. Chip Configuration Mode Selection**

<b>MODE[2:0]</b>	<b>Chip Configuration Mode</b>
111	Master mode
110	Single-chip mode
10X	FAST mode
0XX	Emulation mode

SZEN — TSIZ[1:0] Enable Bits

This read/write bit enables the TSIZ[1:0] function of the external pins.

- 1 = TSIZ[1:0] function enabled
- 0 = TSIZ[1:0] function disabled

PSTEN — PSTAT[3:0] Signal Enable Bits

This read/write bit enables the PSTAT[3:0] function of the external pins.

- 1 = PSTAT[3:0] function enabled
- 0 = PSTAT[3:0] function disabled

SHINT — Show Interrupt Bit

The SHINT bit allows visibility to any active interrupt request to the processor. If the SHINT bit is set, the  $\overline{\text{RSTOUT}}$  pin is the OR of the fast and normal interrupt signals.

- 1 = Internal requests reflected on  $\overline{\text{RSTOUT}}$  pin
- 0 = Normal  $\overline{\text{RSTOUT}}$  pin function

The SHINT bit is read/write always.

**NOTE:** *The FRCRSTOUT function in the reset controller has a higher priority than the SHINT function.*

BME — Bus Monitor External Enable Bit

The BME bit enables the bus monitor to operate during external bus cycles.

- 1 = Bus monitor enabled for external bus cycles
- 0 = Bus monitor disabled for external bus cycles

**Table 4-2** shows the read/write accessibility of this write-once bit.

BMD — Bus Monitor Debug Mode Bit

The BMD bit controls how the bus monitor responds during debug mode.

- 1 = Bus monitor enabled in debug mode
- 0 = Bus monitor disabled in debug mode

This bit is read/write always.



**BMT[1:0] — Bus Monitor Timing Field**

The BMT field selects the timeout time for the bus monitor as shown in [Table 4-5](#).

**Table 4-5. Bus Monitor Timeout Values**

BMT[1:0]	Timeout Period (in System Clocks)
00	64
01	32
10	16
11	8

[Table 4-2](#) shows the read/write accessibility of these write-once bits.

**4.7.3.2 Reset Configuration Register**

The Reset Configuration Register (RCON) is a read-only register; writing to RCON has no effect. At reset, RCON determines the default operation of certain chip functions. All default functions defined by the RCON values may be overridden during reset configuration (see [4.8.1 Reset Configuration](#)) only if the external RCON pin is asserted.

Address: 0x00c1\_0004 and 0x00c1\_0005

	Bit 15	14	13	12	11	10	9	Bit 8
Read:	0	0	0	0	0	0	0	0
Write:								
Reset:	0	0	0	0	0	0	0	0
	Bit 7	6	5	4	3	2	1	Bit 0
Read:	1 RPLLSEL	1 RPLLREF	0 RLOAD	0	1 BOOTPS	0 BOOTSEL	0	0 MODE
Write:								
Reset:	1	1	0	0	1	0	0	0

= Writes have no effect and the access terminates without a transfer error exception.

**Figure 4-3. Reset Configuration Register (RCON)**

**RPLLSEL — PLL Mode Select Bit**

When the PLL is enabled, the read-only RPLLSEL bit reflects the default PLL mode.

1 = Normal PLL mode

0 = 1:1 PLL mode

The default PLL mode can be overridden during reset configuration. If the default mode is overridden, the PLLSEL bit in the clock module SYNSR reflects the PLL mode.

**RPLLREF — PLL Reference Bit**

When the PLL is enabled in normal PLL mode, the read-only RPLLREF bit reflects the default PLL reference.

1 = Crystal oscillator is PLL reference.

0 = External clock is PLL reference.

The default PLL reference can be overridden during reset configuration. If the default mode is overridden, the PLLREF bit in the clock module SYNSR reflects the PLL reference.

**RLOAD — Pad Driver Load Bit**

The read-only RLOAD bit reflects the pad driver strength configuration.

1 = Full drive strength

0 = Default drive strength

The default function of the pad driver strength can be overridden during reset configuration. If the default mode is overridden, the LOAD bit in CCR reflects the pad driver strength configuration.

**BOOTPS — Boot Port Size Bit**

If the boot device is configured to be external, the read-only BOOTPS bit reflects the default selection for the boot port size.

1 = Boot device uses 32-bit port.

0 = Boot device uses 16-bit port.

The default function of the boot port size can be overridden during reset configuration. If the default mode is overridden, the PS bit in CSCR0 reflects the boot device port size configuration.

**BOOTSEL — Boot Select Bit**

This read-only bit reflects the default selection for the boot device.

- 1 = Boot from external boot device
- 0 = Boot from internal boot device

The default function of the boot select can be overridden during reset configuration. If the default mode is overridden, the CSEN bit in CSCR0 bit reflects the boot device configuration.

**MODE — Chip Configuration Mode Bit**

The read-only MODE bit reflects the chip configuration mode.

- 1 = Master mode
- 0 = Single-chip mode

The default mode can be overridden during reset configuration. If the default mode is overridden, the MODE bits in CCR reflect the mode configuration.

**4.7.3.3 Chip Identification Register**

The Chip Identification Register (CIR) is a read-only register; writing to CIR has no effect.

Address: 0x00c1\_0006 and 0x00c1\_0007

	Bit 15	14	13	12	11	10	9	Bit 8
Read:	0 PIN7	0 PIN6	0 PIN5	1 PIN4	1 PIN3	1 PIN2	1 PIN1	0 PIN0
Write:								
Reset:	0	0	0	1	1	1	1	0
	Bit 7	6	5	4	3	2	1	Bit 0
Read:	0 PRN7	0 PRN6	0 PRN5	0 PRN4	0 PRN3	0 PRN2	0 PRN1	0 PRN0
Write:								
Reset:	0	0	0	0	0	0	0	0

= Writes have no effect and the access terminates without a transfer error exception.

**Figure 4-4. Chip Identification Register (CIR)**

Chip Configuration Module (CCM)

PIN[7:0] — Part Identification Number Field

This read-only field contains a unique identification number for the part.

PRN[7:0] — Part Revision Number Field

This read-only field contains the full-layer mask revision number. This number is increased by one for each new full-layer mask set of this part. The revision numbers are assigned in chronological order.

4.7.3.4 Chip Test Register

The Chip Test Register (CTR) is reserved for factory testing.

**NOTE:** To safeguard against unintentionally activating test logic, write \$0000 to the lock out test features. Setting any bit in CTR may lead to unpredictable results.

Address: 0x00c1\_0008 and 0x00c1\_0009

	Bit 15	14	13	12	11	10	9	Bit 8
Read:	0	0	0	0	0	0	0	0
Write:								
Reset:	0	0	0	0	0	0	0	0
	Bit 7	6	5	4	3	2	1	Bit 0
Read:	0	0	0	0	0	0	0	0
Write:								
Reset:	0	0	0	0	0	0	0	0

 = Writes have no effect and the access terminates without a transfer error exception.

Figure 4-5. Chip Test Register (CTR)

## 4.8 Functional Description

Six functions are defined within the chip configuration module:

1. Reset configuration
2. Chip mode selection
3. Boot device selection
4. Output pad strength configuration
5. Clock mode selection
6. Module configuration

These functions are described here.

### 4.8.1 Reset Configuration

During reset, the pins for the reset override functions are immediately configured to known states. [Table 4-6](#) shows the states of the external pins while in reset.

**Table 4-6. Reset Configuration Pin States During Reset**

Pin	Pin Function <sup>(1)</sup>	I/O	Output State	Input State
D[26, 23:21, 19:16], PA[4, 2], PB[7:5, 3:0]	Digital I/O or primary function	Input	—	Must be driven by external logic
$\overline{\text{RCON}}$	$\overline{\text{RCON}}$ function for all modes <sup>(2)</sup>	Input	—	Internal weak pullup device
PLLEN	Not affected	Input	—	Must be driven by external logic

1. If the external  $\overline{\text{RCON}}$  pin is not asserted during reset, pin functions are determined by the default operation mode defined in the RCON register. If the external  $\overline{\text{RCON}}$  pin is asserted, pin functions are determined by the chip operation mode defined by the override values driven on the external data bus pins.
2. During reset, the external  $\overline{\text{RCON}}$  pin assumes its  $\overline{\text{RCON}}$  pin function, but this pin changes to the function defined by the chip operation mode immediately after reset. See [Table 4-7](#).

If the  $\overline{\text{RCON}}$  pin is not asserted during reset, the chip configuration and the reset configuration pin functions after reset are determined by RCON or fixed defaults, regardless of the states of the external data pins. The internal configuration signals are driven to levels specified by the RCON register's reset state for default module configuration.

**Chip Configuration Module (CCM)**

If the external  $\overline{\text{RCON}}$  pin is asserted during reset, then various chip functions, including the reset configuration pin functions after reset, are configured according to the levels driven onto the external data pins. (See [Table 4-7](#).) The internal configuration signals are driven to reflect the levels on the external configuration pins to allow for module configuration.

**Table 4-7. Configuration During Reset<sup>(1)</sup>**

Pin(s) Affected	Default Configuration	Override Pins in Reset <sup>(2),(3)</sup>	Function
D[31:0], $\overline{\text{SHS}}$ , $\overline{\text{TA}}$ , $\overline{\text{TEA}}$ , CSE[1:0], TC[2:0], OE, A[22:0], EB[3:0], CS[3:0]	RCON0 = 0	<b>D[26,17:16]</b>	<b>Chip Mode Selected</b>
		111	Master mode
		110	Single-chip mode <sup>(4)</sup>
		10X	FAST mode
		0XX	Emulation mode
$\overline{\text{CS}}[1:0]$	RCON[3:2] = 10	<b>D[19:18]</b>	<b>Boot Device</b>
		X0	Internal with 32-bit port <sup>(4)</sup>
		01	External with 16-bit port
		11	External with 32-bit port
All output pins	RCON5 = 0	<b>D21</b>	<b>Output Pad Drive Strength</b>
		0	Default strength <sup>(4)</sup>
		1	Full strength
Clock mode	RCON[7:6] = 11	<b>PLLEN, D[23:22]</b>	<b>Clock Mode</b>
		0XX	External clock mode (PLL disabled)
		10X	1:1 PLL mode
		110	Normal PLL mode with external clock reference
		111	Normal PLL mode w/crystal oscillator reference <sup>(4)</sup>

1. Modifying the default configurations is possible only if the external  $\overline{\text{RCON}}$  pin is asserted.
2. The D[31:29, 28, 27, 25:24, 20, 15:0] pins do not affect reset configuration.
3. The external reset override circuitry drives the data bus pins with the override values while  $\overline{\text{RSTOUT}}$  is asserted. It must stop driving the data bus pins within one CLKOUT cycle after  $\overline{\text{RSTOUT}}$  is negated. To prevent contention with the external reset override circuitry, the reset override pins are forced to inputs during reset and do not become outputs until at least one CLKOUT cycle after  $\overline{\text{RSTOUT}}$  is negated.
4. Default configuration

## 4.8.2 Chip Mode Selection

The chip mode is selected during reset and reflected in the MODE field of the Chip Configuration Register (CCR). (See [4.7.3.1 Chip Configuration Register](#).) Once reset is exited, the operating mode cannot be changed. [Table 4-8](#) shows the mode selection during reset configuration.

**Table 4-8. Chip Configuration Mode Selection<sup>(1)</sup>**

Chip Configuration Mode	CCR Register MODE Field		
	MODE2	MODE1	MODE0
Master mode	D26 driven high	D17 driven high	D16 driven high
Single-chip mode	D26 driven high	D17 driven high	D16 driven low
FAST mode	D26 driven high	D17 driven low	D16 don't care
Emulation mode	D26 driven low	D17 don't care	D16 don't care

1. Modifying the default configurations is possible only if the external  $\overline{RCON}$  pin is asserted.

During reset, certain module configurations depend on whether emulation mode is active as determined by the state of the internal emulation signal.

## 4.8.3 Boot Device Selection

During reset configuration, the  $\overline{CS0}$  chip select pin is optionally configured to select an external boot device. In this case, the CSEN bit in CSCR0 is set, enabling  $\overline{CS0}$  after reset.  $\overline{CS0}$  will be asserted for the initial boot fetch accessed from address 0x0. It is assumed that the reset vector loaded from address 0x0 causes the CPU to start executing from external memory space decoded by  $\overline{CS0}$ . Also, the PS bit is configured for either a 16-bit or 32-bit port size depending on the external boot device. See [Table 4-9](#).

In emulation mode, the  $\overline{CS1}$  chip select pin is optionally configured for emulating an internal memory. In emulation mode and booting from internal memory, the CSEN bit in CSCR1 is set, enabling  $\overline{CS1}$  after reset.

**Table 4-9. Chip Select  $\overline{CS0}$  Configuration Encoding**

Chip Select $\overline{CS0}$ Control	CSCR0 Register		CSCR1 Register
	CSEN Bit	PS Bit	CSEN Bit
Chip select disabled (32-bit port size)	0	1	1 <sup>(1)</sup>
Chip select enabled with 16-bit port size	1	0	0
Chip select enabled with 32-bit port size	1	1	0

1. CSCR1 CSEN is initially set only in emulation mode when booting from internal memory and is cleared otherwise.

Once reset is exited, the states of the CSEN and PS bits in CSCR0 and the CSEN bit in CSCR1 remain, but can be modified by software.

The boot device selection during reset configuration is summarized in [Table 4-10](#).

**Table 4-10. Boot Device Selection<sup>(1)</sup>**

Boot Device Selection	CSCR0 Register		CSCR1 Register
	CSEN Bit	PS Bit	CSEN Bit
Internal boot device; default 32-bit port	D18 driven low	D19 don't care	D18 driven low
External boot device with 16-bit port	D18 driven high	D19 driven low	D18 driven high
External boot device with 32-bit port	D18 driven high	D19 driven high	D18 driven high

1. Modifying the default configurations is possible only if the external  $\overline{RCON}$  pin is asserted.



#### 4.8.4 Output Pad Strength Configuration

Output pad strength is determined during reset configuration as shown in [Table 4-11](#). See [23.7 DC Electrical Specifications](#) for drive capability for each setting. Once reset is exited, the output pad strength configuration can be changed by programming the LOAD bit of the Chip Configuration Register.

**Table 4-11. Output Pad Driver Strength Selection<sup>(1)</sup>**

Optional Pin Function Selection	CCR Register LOAD Bit
Output pads configured for default strength	D21 driven low
Output pads configured for full strength	D21 driven high

1. Modifying the default configurations is possible only if the external  $\overline{\text{RCON}}$  pin is asserted low.

#### 4.8.5 Clock Mode Selection

The clock mode is selected during reset and reflected in the PLLMODE, PLLSEL, and PLLREF bits of SYNSR. Once reset is exited, the clock mode cannot be changed.

[Table 4-12](#) summarizes clock mode selection during reset configuration.

**Table 4-12. Clock Mode Selection<sup>(1)</sup>**

Clock Mode	Synthesizer Status Register (SYNSR)		
	MODE Bit	PLLSEL Bit	PLLREF Bit
External clock mode; PLL disabled	PLLEN driven low	D23 don't care	D22 don't care
1:1 PLL mode	PLLEN driven high	D23 driven low	D22 don't care
Normal PLL mode; external clock reference	PLLEN driven high	D23 driven high	D22 driven low
Normal PLL mode; crystal oscillator reference	PLLEN driven high	D23 driven high	D22 driven high

1. Modifying the default configurations is possible only if the external  $\overline{\text{RCON}}$  pin is asserted low.

## Chip Configuration Module (CCM)

### 4.8.6 Internal FLASH Configuration

The internal FLASH in the MMC2113 and MMC2114 is always enabled.

### 4.9 Reset

Reset initializes CCM registers to a known startup state as described in [4.7 Memory Map and Registers](#). The CCM controls chip configuration at reset as described in [4.8 Functional Description](#).

### 4.10 Interrupts

The CCM does not generate interrupt requests.

## Section 5. Reset Controller Module

### 5.1 Contents

5.2	Overview . . . . .	140
5.3	Features . . . . .	140
5.4	Block Diagram . . . . .	141
5.5	Signals . . . . .	141
5.5.1	RESET . . . . .	142
5.5.2	RSTOUT . . . . .	142
5.6	Memory Map and Registers . . . . .	142
5.6.1	Reset Control Register . . . . .	143
5.6.2	Reset Status Register . . . . .	145
5.7	Functional Description . . . . .	147
5.7.1	Reset Sources . . . . .	147
5.7.1.1	Power-On Reset . . . . .	148
5.7.1.2	External Reset . . . . .	148
5.7.1.3	Watchdog Timer Reset . . . . .	148
5.7.1.4	Loss of Clock Reset . . . . .	148
5.7.1.5	Loss of Lock Reset . . . . .	149
5.7.1.6	Software Reset . . . . .	149
5.7.1.7	LVD Reset . . . . .	149
5.7.2	Reset Control Flow . . . . .	149
5.7.2.1	Synchronous Reset Requests . . . . .	151
5.7.2.2	Internal Reset Request . . . . .	151
5.7.2.3	Power-On Reset/Low-Voltage Detect Reset . . . . .	151
5.7.3	Concurrent Resets . . . . .	152
5.7.3.1	Reset Flow . . . . .	152
5.7.3.2	Reset Status Flags . . . . .	152

## 5.2 Overview

The reset controller is provided to determine the cause of reset, assert the appropriate reset signals to the system, and then to keep a history of what caused the reset. The power management CPU (PMM) control registers that generate low-voltage detect (LVD) bits are implemented in the reset module.

## 5.3 Features

Module features include:

- Six sources of reset:
  - External
  - Power-on reset (POR)
  - Watchdog timer
  - Phase locked-loop (PLL) loss of lock
  - PLL loss of clock
  - Software
  - LVD reset
- Software-assertable  $\overline{\text{RSTOUT}}$  pin independent of chip reset state
- Software-readable status flags indicating the cause of the last reset
- LVD control and status bits for setup and use of LVD reset or interrupt

### 5.4 Block Diagram

Figure 5-1 illustrates the reset controller and PMM controller and is explained in the following sections.

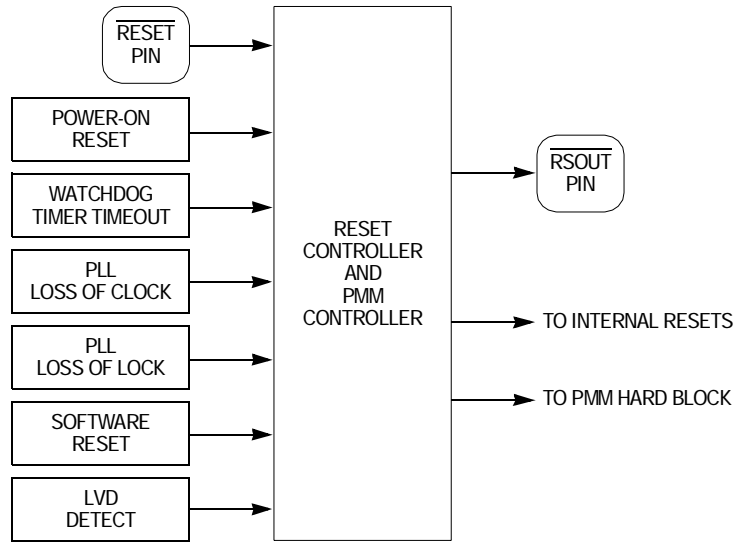

Figure 5-1. Reset Controller Block Diagram

### 5.5 Signals

Table 5-1 provides a summary of the reset controller signal properties. The signals are described in the following paragraphs.

Table 5-1. Reset Controller Signal Properties

Name	Direction	Input Hysteresis	Input Synchronization
$\overline{\text{RESET}}$ pin	I	Y	$\gamma^{(1)}$
$\overline{\text{RSTOUT}}$ pin	O	—	—

1.  $\overline{\text{RESET}}$  is always synchronized except when in low-power stop mode.

**Reset Controller Module**

**5.5.1  $\overline{\text{RESET}}$**

Asserting the external  $\overline{\text{RESET}}$  pin for at least four rising CLKOUT edges causes the external reset request to be recognized and latched.

**5.5.2  $\overline{\text{RSTOUT}}$**

This active-low output signal is driven low when the internal reset controller module resets the chip. When  $\overline{\text{RSTOUT}}$  is active, the user can drive override options on the data bus.

**5.6 Memory Map and Registers**

The reset controller programming model consists of these registers:

- Reset Control Register (RCR) — selects reset controller functions
- Reset Status Register (RSR) — reflects the state of the last reset source

See [Table 5-2](#) for the address map and the following paragraphs for a description of the registers.

**Table 5-2. Reset Controller Address Map**

Address	Bits 7:0	Access <sup>(1)</sup>
0x00c4_0000	RCR — Reset Control Register	S/U
0x00c4_0001	RSR — Reset Status Register	S/U
0x00c4_0002	Reserved <sup>(2)</sup>	—
0x00c4_0003	Reserved <sup>(2)</sup>	—

1. S/U = supervisor or user mode access.  
 2. Writes to reserved address locations have no effect and reads return 0s.

### 5.6.1 Reset Control Register

The Reset Control Register (RCR) allows software control for requesting a reset, for independently asserting the external  $\overline{RSTOUT}$  pin, and for controlling low-voltage detect (LVD) functions.

Address: 0x00c4\_0000

	Bit 7	6	5	4	3	2	1	Bit 0
Read:	SOFTRST	FRCR-STOUT	0	LVDF	LV DIE	LVDRE	LVDSE	LVDE
Write:								
Reset:	0	0	0	See note	0	1	1	1

Note: Reset dependent

= Writes have no effect and terminate without transfer error exception.

**Figure 5-2. Reset Control Register (RCR)**

#### SOFTRST — Software Reset Request

The SOFTRST bit allows software to request a reset. The reset caused by setting this bit clears this bit.

1 = Software reset request

0 = No software reset request

#### FRCRSTOUT — Force $\overline{RSTOUT}$ Pin

The FRCRSTOUT bit allows software to assert or negate the external  $\overline{RSTOUT}$  pin.

1 = Assert  $\overline{RSTOUT}$  pin

0 = Negate  $\overline{RSTOUT}$  pin

**CAUTION:** *External logic driving reset configuration data during reset needs to be considered when asserting the  $\overline{RSTOUT}$  pin when setting FRCRSTOUT.*

## LVDF — LVD Flag

The LVDF bit indicates the low-voltage detect status if LVDE is set. Write a 1 to clear the LVDF bit.

1 = Low voltage has been detected

0 = Low voltage has not been detected

**NOTE:** *The setting of this flag causes an LVD interrupt if LVDE and LVDIE bits are set and LVDRE is cleared when the supply voltage  $V_{DD}$  drops below  $V_{DD}$  (minimum). The vector for this interrupt is shared with INTO of the EPORT module. Interrupt arbitration in the interrupt service routine is necessary if both of these interrupts are enabled.*

## LVDIE — LVD Interrupt Enable

The LVDIE bit controls the LVD interrupt if LVDE is set. This bit has no effect if the LVDE bit is a logic 0.

1 = LVD interrupt enabled

0 = LVD interrupt disabled

## LVDRE — LVD Reset Enable

The LVDRE bit controls the LVD reset if LVDE is set. This bit has no effect if the LVDE bit is a logic 0. LVD reset has priority over LVD interrupt, if both are enabled.

1 = LVD reset enabled

0 = LVD reset disabled

## LVDSE — LVD Stop Enable

The LVDSE bit controls the behavior of the LVD when the MCU stop mode is entered if LVDE is set. This bit has no effect if the LVDE bit is a logic 0.

1 = LVD enabled in MCU stop mode

0 = LVD disabled in MCU stop mode

## LVDE — LVD Enable

The LVDE bit controls whether the LVD is enabled.

1 = LVD is enabled

0 = LVD is disabled



### 5.6.2 Reset Status Register

The Reset Status Register (RSR) contains a status bit for every reset source. When reset is entered, the cause of the reset condition is latched along with a value of 0 for the other reset sources that were not pending at the time of the reset condition. These values are then reflected in RSR. One or more status bits may be set at the same time. The cause of any subsequent reset is also recorded in the register, overwriting status from the previous reset condition.

RSR can be read at any time. Writing to RSR has no effect.

Address: 0x00c4\_0001

	Bit 7	6	5	4	3	2	1	Bit 0
Read:	0	LVD	SOFT	WDR	POR	EXT	LOC	LOL
Write:								
Reset:	0	Reset dependent						

 = Writes have no effect and terminate without transfer error exception.

**Figure 5-3. Reset Status Register (RSR)**

#### LVD — Low-Voltage Detect

This bit indicates that the last reset state was caused by an LVD reset.

1 = Last reset state was caused by an LVD reset

0 = Last reset state was not caused by an LVD reset

#### SOFT — Software Reset Flag

SOFT indicates that the last reset was caused by software.

1 = Last reset caused by software

0 = Last reset not caused by software

#### WDR — Watchdog Timer Reset Flag

WDR indicates that the last reset was caused by a watchdog timer timeout.

1 = Last reset caused by watchdog timer timeout

0 = Last reset not caused by watchdog timer timeout

**POR — Power-On Reset Flag**

POR indicates that the last reset was caused by a power-on reset.

1 = Last reset caused by power-on reset

0 = Last reset not caused by power-on reset

**EXT — External Reset Flag**

EXT indicates that the last reset was caused by an external device asserting the external  $\overline{\text{RESET}}$  pin.

1 = Last reset state caused by external reset

0 = Last reset not caused by external reset

**LOC — Loss of Clock Reset Flag**

LOC indicates that the last reset state was caused by a PLL los of clock.

1 = Last reset caused by loss of clock

0 = Last reset not caused by loss of clock

**LOL — Loss of Lock Reset Flag**

LOL indicates that the last reset state was caused by a PLL loss of lock.

1 = Last reset caused by a loss of lock

0 = Last reset not caused by loss of lock

## 5.7 Functional Description

### 5.7.1 Reset Sources

**Table 5-3** defines the sources of reset and the signals driven by the reset controller.

**Table 5-3. Reset Source Summary**

Source	Type
Power on	Asynchronous
External $\overline{\text{RESET}}$ pin (not stop mode)	Synchronous
External $\overline{\text{RESET}}$ pin (during stop mode)	Asynchronous
Watchdog timer	Synchronous
Loss of clock	Asynchronous
Loss of lock	Asynchronous
Software	Synchronous
LVD reset	Asynchronous

To protect data integrity, a synchronous reset source is not acted upon by the reset control logic until the end of the current bus cycle. Reset is then asserted on the next rising edge of the system clock after the cycle is terminated. Whenever the reset control logic must synchronize reset to the end of the bus cycle, the internal bus monitor is automatically enabled regardless of the BME bit state in the chip configuration module CCR register. Then, if the current bus cycle is not terminated normally the bus monitor terminates the cycle based on the length of time programmed in the BMT field of the CCR register.

Internal single-byte, half-word, or word writes are guaranteed to complete without data corruption when a synchronous reset occurs. External writes, including word writes to 16-bit ports, are also guaranteed to complete.

Asynchronous reset sources usually indicate a catastrophic failure. Therefore, the reset control logic does not wait for the current bus cycle to complete. Reset is asserted immediately to the system.

## Reset Controller Module

### 5.7.1.1 Power-On Reset

At power up, the reset controller asserts  $\overline{\text{RSTOUT}}$ .  $\overline{\text{RSTOUT}}$  continues to be asserted until  $V_{\text{DD}}$  has reached a minimum acceptable level and, if PLL clock mode is selected, until the PLL achieves phase lock. Then after approximately another 512 cycles,  $\overline{\text{RSTOUT}}$  is negated and the part begins operation.

### 5.7.1.2 External Reset

Asserting the external  $\overline{\text{RESET}}$  pin for at least four rising CLKOUT edges causes the external reset request to be recognized and latched. The bus monitor is enabled and the current bus cycle is completed. The reset controller asserts  $\overline{\text{RSTOUT}}$  for approximately 512 cycles after the  $\overline{\text{RESET}}$  pin is negated and the PLL has acquired lock. The part then exits reset and begins operation.

In low-power stop mode, the system clocks are stopped. Asserting the external  $\overline{\text{RESET}}$  pin in stop mode causes an external reset to be recognized.

### 5.7.1.3 Watchdog Timer Reset

A watchdog timer timeout causes timer reset request to be recognized and latched. The bus monitor is enabled and the current bus cycle is completed. If the  $\overline{\text{RESET}}$  pin is negated and the PLL has acquired lock, the reset controller asserts  $\overline{\text{RSTOUT}}$  for approximately 512 cycles. Then the part exits reset and begins operation.

### 5.7.1.4 Loss of Clock Reset

This reset condition occurs in PLL clock mode when the LOCRE bit in the SYNCR register is set and either the PLL reference or the PLL fails. The reset controller asserts  $\overline{\text{RSTOUT}}$  for approximately 512 cycles after the PLL has acquired lock. The part then exits reset and begins operation.

#### 5.7.1.5 Loss of Lock Reset

This reset condition occurs in PLL clock mode when the LOLRE bit in the SYNCR register is set and the PLL loses lock. The reset controller asserts  $\overline{\text{RSTOUT}}$  for approximately 512 cycles after the PLL has acquired lock. The part then exits reset and resumes operation.

#### 5.7.1.6 Software Reset

A software reset occurs the SOFTRST bit is set. If the  $\overline{\text{RESET}}$  pin is negated and the PLL has acquired lock, the reset controller asserts  $\overline{\text{RSTOUT}}$  for approximately 512 cycles. Then the part exits reset and resumes operation.

#### 5.7.1.7 LVD Reset

The LVD reset will occur when the supply input voltage drops below  $V_{DD}$  (minimum).

### 5.7.2 Reset Control Flow

The reset logic control flow is shown in [Figure 5-4](#). In this figure, the control state boxes have been numbered, and these numbers are referred to (within parentheses) in the flow description that follows. All cycle counts given are approximate.

Reset Controller Module

Freescale Semiconductor, Inc.

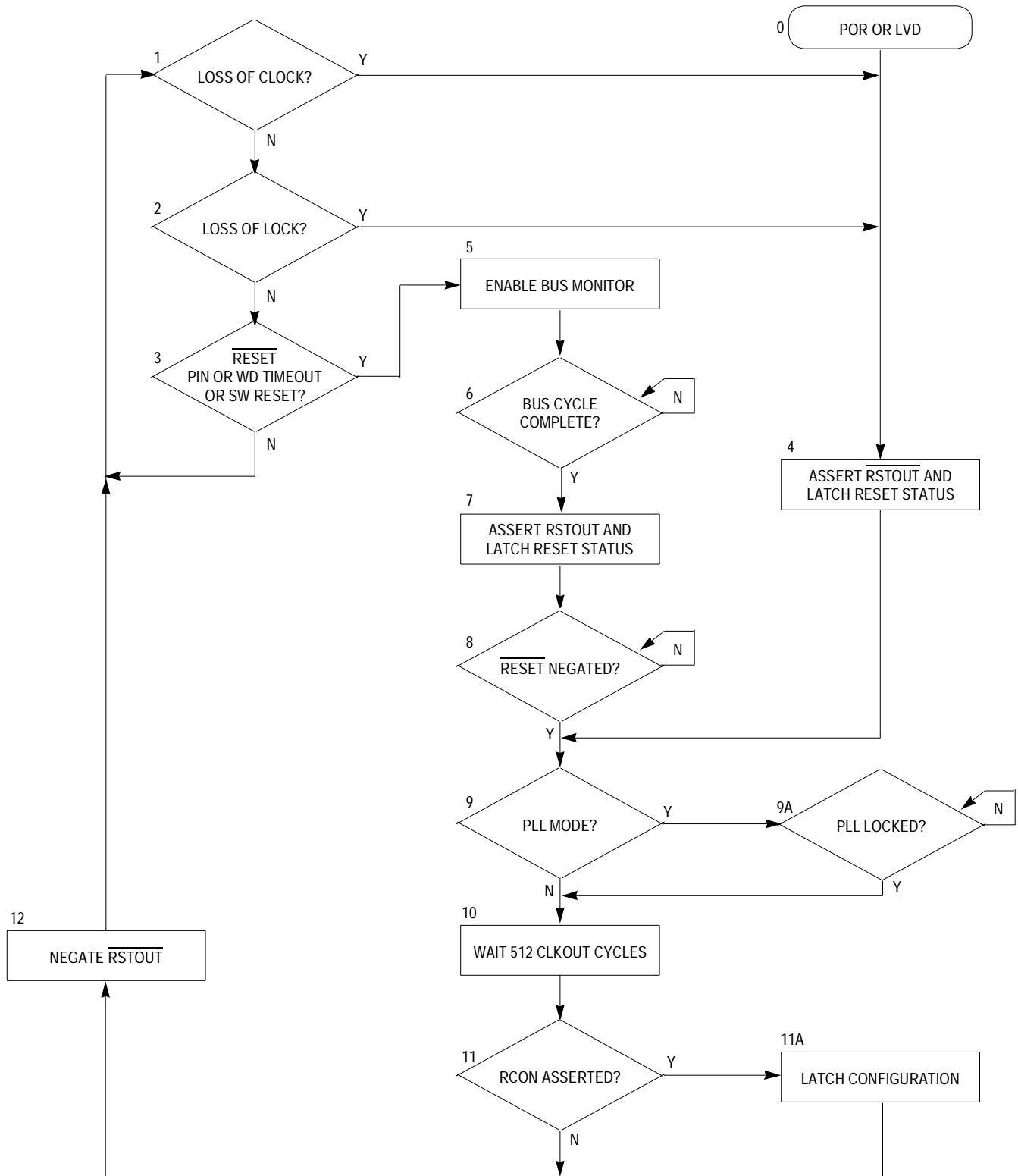

Figure 5-4. Reset Control Flow

### 5.7.2.1 Synchronous Reset Requests

In this discussion, the reference in parentheses refer to the state numbers in **Figure 5-4**. All cycle counts given are approximate.

If either the external  $\overline{\text{RESET}}$  pin is asserted by an external device for at least four rising CLKOUT edges (3), or the watchdog timer times out, or software requests a reset, the reset control logic latches the reset request internally and enables the bus monitor (5). When the current bus cycle is completed (6),  $\overline{\text{RSTOUT}}$  is asserted (7). The reset control logic waits until the  $\overline{\text{RESET}}$  pin is negated (8) and for the PLL to attain lock (9, 9A) before waiting 512 CLKOUT cycles (1). The reset control logic may latch the configuration according to the  $\overline{\text{RCON}}$  pin level (11, 11A) before negating  $\overline{\text{RSTOUT}}$  (12).

If the external  $\overline{\text{RESET}}$  pin is asserted by an external device for at least four rising CLKOUT edges during the 512 count (10) or during the wait for PLL lock (9A), the reset flow switches to (8) and waits for the  $\overline{\text{RESET}}$  pin to be negated before continuing.

### 5.7.2.2 Internal Reset Request

If reset is asserted by an asynchronous internal reset source, such as loss of clock (1) or loss of lock (2), the reset control logic asserts  $\overline{\text{RSTOUT}}$  (4). The reset control logic waits for the PLL to attain lock (9, 9A) before waiting 512 CLKOUT cycles (1). Then the reset control logic may latch the configuration according to the  $\overline{\text{RCON}}$  pin level (11, 11A) before negating  $\overline{\text{RSTOUT}}$  (12).

If loss of lock occurs during the 512 count (10), the reset flow switches to (9A) and waits for the PLL to lock before continuing.

### 5.7.2.3 Power-On Reset/Low-Voltage Detect Reset

When the reset sequence is initiated by power-on reset (0), the same reset sequence is followed as for the other asynchronous reset sources.

### 5.7.3 Concurrent Resets

This section describes the concurrent resets. As in the previous discussion references in parentheses refer to the state numbers in [Figure 5-4](#).

#### 5.7.3.1 Reset Flow

If a power-on reset or low-voltage detect condition is detected during any reset sequence, the reset sequence starts immediately (0).

If the external  $\overline{\text{RESET}}$  pin is asserted for at least four rising CLKOUT edges while waiting for PLL lock or the 512 cycles, the external reset is recognized. Reset processing switches to wait for the external  $\overline{\text{RESET}}$  pin to negate (8).

If a loss of clock or loss of lock condition is detected while waiting for the current bus cycle to complete (5, 6) for an external reset request, the cycle is terminated. The reset status bits are latched (7) and reset processing waits for the external  $\overline{\text{RESET}}$  pin to negate (8).

If a loss of clock or loss of lock condition is detected during the 512 cycle wait, the reset sequence continues after a PLL lock (9, 9A).

#### 5.7.3.2 Reset Status Flags

For a POR reset, the POR and LVD bits in the RSR register are set, and the SOFT, WDR, EXT, LOC, and LOL bits are cleared even if another type of reset condition is detected during the reset sequence for the POR.

If a loss of clock or loss of lock condition is detected while waiting for the current bus cycle to complete (5, 6) for an external reset request, the EXT, SOFT, and/or WDR bits along with the LOC and/or LOL bits are set.

If the RSR bits are latched (7) during the EXT, SOFT, and/or WDR reset sequence with no other reset conditions detected, only the EXT, SOFT, and/or WDR bits are set.



If the RSR bits are latched (4) during the internal reset sequence with the  $\overline{\text{RESET}}$  pin not asserted and no SOFT or WDR event, then the LOC and/or LOL bits are the only bits set.

For a LVD reset, the LVD bit in the Reset Status Register (RSR) is set, and the SOFT, WDR, EXT, LOC, and LOL bits are cleared to 0 even if another type of reset condition is detected during the reset sequence for LVD.



## Section 6. Power Management

### 6.1 Contents

6.2	Introduction . . . . .	156
6.3	Low-Power Modes . . . . .	156
6.3.1	Run Mode . . . . .	156
6.3.2	Wait Mode . . . . .	157
6.3.3	Doze Mode . . . . .	157
6.3.4	Stop Mode . . . . .	157
6.3.5	Peripheral Shut Down . . . . .	157
6.4	Peripheral Behavior in Low-Power Modes . . . . .	158
6.4.1	Reset . . . . .	158
6.4.2	Clocks . . . . .	158
6.4.3	OnCE . . . . .	159
6.4.4	JTAG . . . . .	160
6.4.5	Interrupt Controller . . . . .	160
6.4.6	Edge Port . . . . .	160
6.4.7	Random-Access Memory (RAM) . . . . .	160
6.4.8	FLASH . . . . .	161
6.4.9	Queued Analog-to-Digital Converter (QADC) . . . . .	161
6.4.10	Watchdog Timer . . . . .	161
6.4.11	Programmable Interrupt Timers (PIT1 and PIT2) . . . . .	162
6.4.12	Serial Peripheral Interface (SPI) . . . . .	162
6.4.13	Serial Communication Interfaces (SCI1 and SCI2) . . . . .	162
6.4.14	Timers (TIM1 and TIM2) . . . . .	163
6.5	Summary of Peripheral State During Low-Power Modes . . . . .	163

## 6.2 Introduction

The following features support low power operation.

- Four modes of operation:
  - Run
  - Wait
  - Doze
  - Stop
- Ability to shut down most peripherals independently
- Ability to shut down the external CLKOUT pin

## 6.3 Low-Power Modes

The system enters a low-power mode by execution of a STOP, WAIT, or DOZE instruction. This idles the CPU with no cycles active. An internal signal indicates to the system and clock controller to power down and stop the clocks appropriately. During stop mode, the system clock is stopped low.

A wakeup event is required to exit a low-power mode and return to run mode. Wakeup events consist of any of these conditions:

- Any type of reset
- Assertion of the  $\overline{DE}$  pin to request entry into debug mode
- Debug request bit set in the OnCE Control Register to request entry into debug mode
- Any valid interrupt request

### 6.3.1 Run Mode

Run mode is the normal system operating mode. Current consumption in this mode is related directly to the system clock frequency.

### 6.3.2 Wait Mode

Wait mode is intended to be used to stop only the CPU and memory clocks until a wakeup event is detected. In this mode, peripherals may be programmed to continue operating and can generate interrupts, which cause the CPU to exit from wait mode.

### 6.3.3 Doze Mode

Doze mode affects the CPU in the same manner as wait mode, except that each peripheral defines individual operational characteristics in doze mode. Peripherals which continue to run and have the capability of producing interrupts may cause the CPU to exit the doze mode and return to run mode. Peripherals which are stopped will restart operation on exit from doze mode as defined for each peripheral.

### 6.3.4 Stop Mode

Stop mode affects the CPU in the same manner as the wait and doze modes, except that all clocks to the system are stopped and the peripherals cease operation.

Stop mode must be entered in a controlled manner to ensure that any current operation is properly terminated. When exiting stop mode, most peripherals retain their pre-stop status and resume operation.

The following subsections specify the operation of each module while in and when exiting low-power modes.

### 6.3.5 Peripheral Shut Down

Most peripherals may be disabled by software in order to cease internal clock generation and remain in a static state. Each peripheral has its own specific disabling sequence (refer to each peripheral description for further details). A peripheral may be disabled at any time and will remain disabled during any low-power mode of operation.

## 6.4 Peripheral Behavior in Low-Power Modes

### 6.4.1 Reset

A power-on reset (POR) will always cause a chip reset and exit from any low-power mode.

In wait and doze modes, asserting the external  $\overline{\text{RESET}}$  pin for at least four clocks will cause an external reset that will reset the chip and exit any low-power modes.

In stop mode, the  $\overline{\text{RESET}}$  pin synchronization is disabled and asserting the external  $\overline{\text{RESET}}$  pin will asynchronously generate an internal reset and exit any low-power modes. Registers will lose current values and must be reconfigured from reset state if needed.

If the phase lock loop (PLL) is active, then any loss of clock or loss of lock will reset the chip and exit any low-power modes.

If the watchdog timer is still enabled during wait or doze modes, then a watchdog timer timeout may generate a reset to exit these low-power modes.

When the CPU is inactive, a software reset can not be generated to exit any low-power mode.

### 6.4.2 Clocks

During the low power wait and doze modes, the clocks to the CPU, FLASH, and random-access memory (RAM) will be stopped and the system clocks to the peripherals are enabled. Each module may disable the module clocks locally at the module level. During the low-power stop mode, all clocks to the system will be stopped.

During stop mode, there are several options for enabling/disabling the PLL and/or crystal oscillator (OSC) compromising between wakeup recovery time and stop mode power. The PLL may be disabled during stop. A wakeup time of up to 200  $\mu\text{s}$  is required for the PLL to re-lock. The OSC may also be disabled during STOP. A wakeup time required

for the OSC to restart is dependent upon the startup time of the crystal used. Power consumption can be reduced in stop mode by disabling either or both of these functions via the STMPD bits of the Synthesizer Control Register (SYNCR). See [11.7.2.1 Synthesizer Control Register](#).

The external CLKOUT signal may be enabled during low-power stop (if the PLL is still enabled) to support systems using this signal as the clock source.

The system clocks may be enabled during wakeup from stop mode without waiting for the PLL to lock. This eliminates the wakeup recovery time, but at the risk of sending a potentially unstable clock to the system. It is recommended, if this option is used, that the PLL frequency divider is set so that the targeted system frequency is no more than half the maximum allowed. This will allow for any frequency overshoot of the PLL while still keeping the system clock within specification.

In external clock mode, there are no wait times for the OSC startup or PLL lock.

During wakeup from stop mode, the FLASH clock will always clock through 16 cycles before the system clocks are enabled. This allows the FLASH module time to recover from the low-power mode. Thus, software may immediately continue to fetch instructions from the FLASH memory.

The external CLKOUT output pin may be disabled in the low state to lower power consumption via the disable CLKOUT (DISCLK) bit in the SYNCR. The external CLKOUT pin function is enabled by default at reset.

### 6.4.3 OnCE

The OnCE logic is clocked using the TCLK input and is not affected by the system clock. Entering debug mode via the OnCE port (or asserting the external  $\overline{DE}$  pin) will cause the CPU to exit any low-power mode. Toggling TCLK during any low-power mode will increase the system current consumption.

#### 6.4.4 JTAG

The JTAG (Joint Test Action Group) controller logic is clocked using the TCLK input and is not affected by the system clock. The JTAG cannot generate an event to cause the CPU to exit any low-power mode. Toggling TCLK during any low-power mode will increase the system current consumption.

#### 6.4.5 Interrupt Controller

The interrupt controller is not affected by any of the low-power modes. All logic between the input sources and generating the interrupt to the M•CORE processor will be combinational to allow the ability to wakeup the CPU processor during low-power stop mode when all system clocks are stopped.

A fast interrupt request will cause the CPU to exit a low-power mode only if the FE bit in the CPU's PSR register is set. A normal interrupt request will cause the CPU to exit a low-power mode only if the IE and EE bits in the CPU's PSR register are set.

#### 6.4.6 Edge Port

In wait and doze modes, the edge port continues to operate normally and may be configured to generate interrupts (either an edge transition or low level on an external pin) to exit the low-power modes.

In stop mode, there are no clocks available to perform the edge detect function. Thus, only the level detect logic is active (if configured) to allow any low level on the external interrupt pin to generate an interrupt (if enabled) to exit the stop mode.

#### 6.4.7 Random-Access Memory (RAM)

The random-access memory (RAM) is disabled during any low-power mode. No recovery time is required when exiting any low-power mode.



## 6.4.8 FLASH

The FLASH is in a low-power state if not being accessed. No recovery time is required after exit from any low-power mode.

## 6.4.9 Queued Analog-to-Digital Converter (QADC)

Setting the queued analog-to-digital converter (QADC) STOP bit (QSTOP) will disable the QADC.

The QADC is unaffected by either wait or doze mode and may generate an interrupt to exit these modes.

Low-power stop mode (or setting the QSTOP bit), immediately freezes operation, register values, state machines, and external pins. This stops the clock signals to the digital electronics of the module and eliminates the quiescent current draw of the analog electronics. Any conversion sequences in progress are stopped. Exit from low-power stop mode (or clearing the QSTOP bit), returns the QADC to operation from the state prior to stop mode entry, but any conversions in progress are undefined and the QADC requires recovery time ( $t_{SR}$  in [23.9 QADC Electrical Characteristics](#)) to stabilize the analog circuits before new conversions can be performed.

## 6.4.10 Watchdog Timer

In stop mode (or in wait/doze mode, if so programmed), the watchdog ceases operation and freezes at the current value. When exiting these modes, the watchdog resumes operation from the stopped value. It is the responsibility of software to avoid erroneous operation.

When not stopped, the watchdog may generate a reset to exit the low-power modes.

#### 6.4.11 Programmable Interrupt Timers (PIT1 and PIT2)

In stop mode (or in doze mode, if so programmed), the programmable interrupt timer (PIT) ceases operation, and freezes at the current value. When exiting these modes, the PIT resumes operation from the stopped value. It is the responsibility of software to avoid erroneous operation.

When not stopped, the PIT may generate an interrupt to exit the low-power modes.

#### 6.4.12 Serial Peripheral Interface (SPI)

When not stopped, the serial peripheral interface (SPI) may generate an interrupt to exit the low-power modes.

- Clearing the SPI enable bit (SPE) disables the SPI function.
- The SPI is unaffected by wait mode and may generate an interrupt to exit this mode.

SPI operation in doze mode is programmable. Depending on the state of internal bits, the SPI can operate normally when the CPU is in doze mode or the SPI clock generation can be turned off and the SPI module enters a power conservation state during doze mode. During doze mode, any master transmission in progress stops. Reception and transmission of a byte as slave continues so that the slave is synchronized to the master.

The SPI is inactive in stop mode for reduced power consumption.

#### 6.4.13 Serial Communication Interfaces (SCI1 and SCI2)

When not stopped, the serial communications interface (SCI) may generate an interrupt to exit the low-power modes.

- Clearing the transmit enable bit (TE) or the receiver enable bit (RE) disables SCI functions.
- The SCIs are unaffected by wait mode and may generate an interrupt to exit this mode.

In stop mode (or doze mode, if so programmed), the SCIs stop immediately and freeze their operation, register values, state machines, and external pins. During these modes, the SCI clocks are shut down. Coming out of the doze or stop modes, returns the SCIs to operation from the state prior to the low-power mode entry.

#### 6.4.14 Timers (TIM1 and TIM2)

When not stopped, the timers may generate an interrupt to exit the low-power modes.

Clearing the timer enable bit (TE) in the Timer System Control Register 1 (TIMSCR1) or the pulse accumulator enable bit (PAE) in the Pulse Accumulator Control Register (TIMPACTL) disables timer functions. Timer and pulse accumulator registers are still accessible by the CPU and OnCE interface, but the remaining functions of the timer are disabled. See [16.7.6 Timer System Control Register 1](#) and [16.7.15 Pulse Accumulator Control Register](#).

The timer is unaffected by either the wait or doze modes and may generate an interrupt to exit these modes.

In stop mode, the timers stop immediately and freeze their operation, register values, state machines, and external pins. Upon exiting stop mode, the timer will resume operation unless stop mode was exited by reset.

### 6.5 Summary of Peripheral State During Low-Power Modes

The functionality of each of the peripherals and CPU during the various low-power modes is summarized in [Table 6-1](#). The status of each peripheral during a given mode refers to the condition the peripheral automatically assumes when the particular instruction (WAIT, DOZE, or STOP) is executed. Individual peripherals may be disabled by programming its dedicated control bits. The wakeup capability field refers to the ability of an interrupt or reset by that peripheral to force the CPU into run mode.

**Table 6-1. CPU and Peripherals in Low-Power Modes**

Module	Peripheral Status <sup>(1)</sup> / Wakeup Capability						
	Run Mode	Wait Mode		Doze Mode		Stop Mode	
CPU	Enabled	Stopped	No	Stopped	No	Stopped	No
Reset	Enabled	Enabled	Yes <sup>(2)</sup>	Enabled	Yes <sup>(2)</sup>	Enabled	Yes <sup>(2)</sup>
Clock	Enabled	Enabled	Yes <sup>(2)</sup>	Enabled	Yes <sup>(2)</sup>	Program	Yes <sup>(2)</sup>
OnCE	Enabled	Enabled	Yes <sup>(3)</sup>	Enabled	Yes <sup>(3)</sup>	Enabled	Yes <sup>(3)</sup>
JTAG	Enabled	Enabled	No	Enabled	No	Enabled	No
Interrupt controller	Enabled	Enabled	Yes <sup>(4)</sup>	Enabled	Yes <sup>(4)</sup>	Enabled	Yes <sup>(4)</sup>
Edge port	Enabled	Enabled	Yes <sup>(4)</sup>	Enabled	Yes <sup>(4)</sup>	Stopped	Yes <sup>(4)</sup>
RAM	Enabled	Stopped	No	Stopped	No	Stopped	No
FLASH	Enabled	Stopped	No	Stopped	No	Stopped	No
QADC	Enabled	Enabled	Yes <sup>(4)</sup>	Enabled	Yes <sup>(4)</sup>	Stopped	No
Watchdog timer	Enabled	Program	Yes <sup>(2)</sup>	Program	Yes <sup>(2)</sup>	Stopped	No
PIT1 and PIT2	Enabled	Enabled	Yes <sup>(4)</sup>	Program	Yes <sup>(4)</sup>	Stopped	No
SPI	Enabled	Enabled	Yes <sup>(4)</sup>	Program	Yes <sup>(4)</sup>	Stopped	No
SCI1 and SCI2	Enabled	Enabled	Yes <sup>(4)</sup>	Program	Yes <sup>(4)</sup>	Stopped	No
TIM1 and TIM2	Enabled	Enabled	Yes <sup>(4)</sup>	Enabled	Yes <sup>(4)</sup>	Stopped	No

1. "Program" Indicates that the peripheral function during the low-power mode is dependent on programmable bits in the peripheral register map.
2. These modules can generate a reset which will exit any low-power mode.
3. The OnCE logic is clocked by a separate TCLK clock. Entering debug mode via the OnCE port (or assertion of the external DE pin) exits any low-power mode. Upon exit from debug mode, the previous low-power mode will be re-entered and the changes made during debug mode will remain in effect.
4. These modules can generate an interrupt which will exit any low-power mode. The CPU will begin to service the interrupt exception after wakeup.

## **Section 7. M•CORE M210 Central Processor Unit (CPU)**

### **7.1 Contents**

7.2	Introduction . . . . .	165
7.3	Features . . . . .	166
7.4	Microarchitecture Summary . . . . .	167
7.5	Programming Model . . . . .	169
7.6	Data Format Summary . . . . .	171
7.7	Operand Addressing Capabilities . . . . .	172
7.8	Instruction Set Overview . . . . .	172

### **7.2 Introduction**

The M•CORE M210 central processor unit (CPU) architecture is one of the most compact, full 32-bit core implementations available. The pipelined reduced instruction set computer (RISC) execution unit uses 16-bit instructions to achieve maximum speed and code efficiency, while conserving on-chip memory resources. The instruction set is designed to support high-level language implementation. A non-intrusive resident debugging system supports product development and in-situ testing.

Total system power consumption is determined by all the system components, rather than the CPU alone. In particular, memory power consumption (both on-chip and external) is a dominant factor in total power consumption of the CPU plus memory subsystem. With this in mind, the CPU instruction set architecture trades absolute performance capability for reduced total energy consumption. This is accomplished while maintaining a high level of performance at a given clock frequency.

A strictly defined load/store architecture minimizes control complexity. Use of a fixed, 16-bit instruction encoding significantly lowers the memory bandwidth needed to sustain a high rate of instruction execution, and careful selection of the instruction set allows the code density and overall memory efficiency of the CPU architecture to surpass those of complex instruction set computer (CISC) architectures.

These factors reduce system energy consumption significantly, and the fully static CPU design uses other techniques to reduce power consumption even more. The CPU uses dynamic clock management to automatically power-down internal functions that are not in use on a clock-by-clock basis. It also incorporates three power-conservation operating modes, which are invoked via dedicated instructions as detailed in [Section 6. Power Management](#).

### 7.3 Features

The main features of the CPU are:

- 32-bit load/store RISC architecture
- Fixed 16-bit instruction length
- 13 entry, 32-bit control register file
- 16 entry, 32-bit general-purpose register file
- Efficient 4-stage execution pipeline
- Single-cycle execution for most instructions, 2-cycle branches and memory accesses
- Support for byte/half-word/word memory access
- Fast interrupt support
- Availability of alternate general purpose register file
- Vectored and autovectored interrupt support
- On-chip emulation support (OnCE)
- Full static design for minimal power consumption

## 7.4 Microarchitecture Summary

**Figure 7-1** is a block diagram of the M•CORE processor.

The processor utilizes a 4-stage pipeline for instruction execution. The instruction fetch, instruction decode/register file read, execute, and register file writeback stages operate in an overlapped fashion, allowing single clock instruction execution for most instructions.

The execution unit consists of a 32-bit arithmetic/logic unit (ALU), a 32-bit barrel shifter, a find-first-one unit, result feed-forward hardware, support hardware for multiplication and division, and multiple-register load and store instructions.

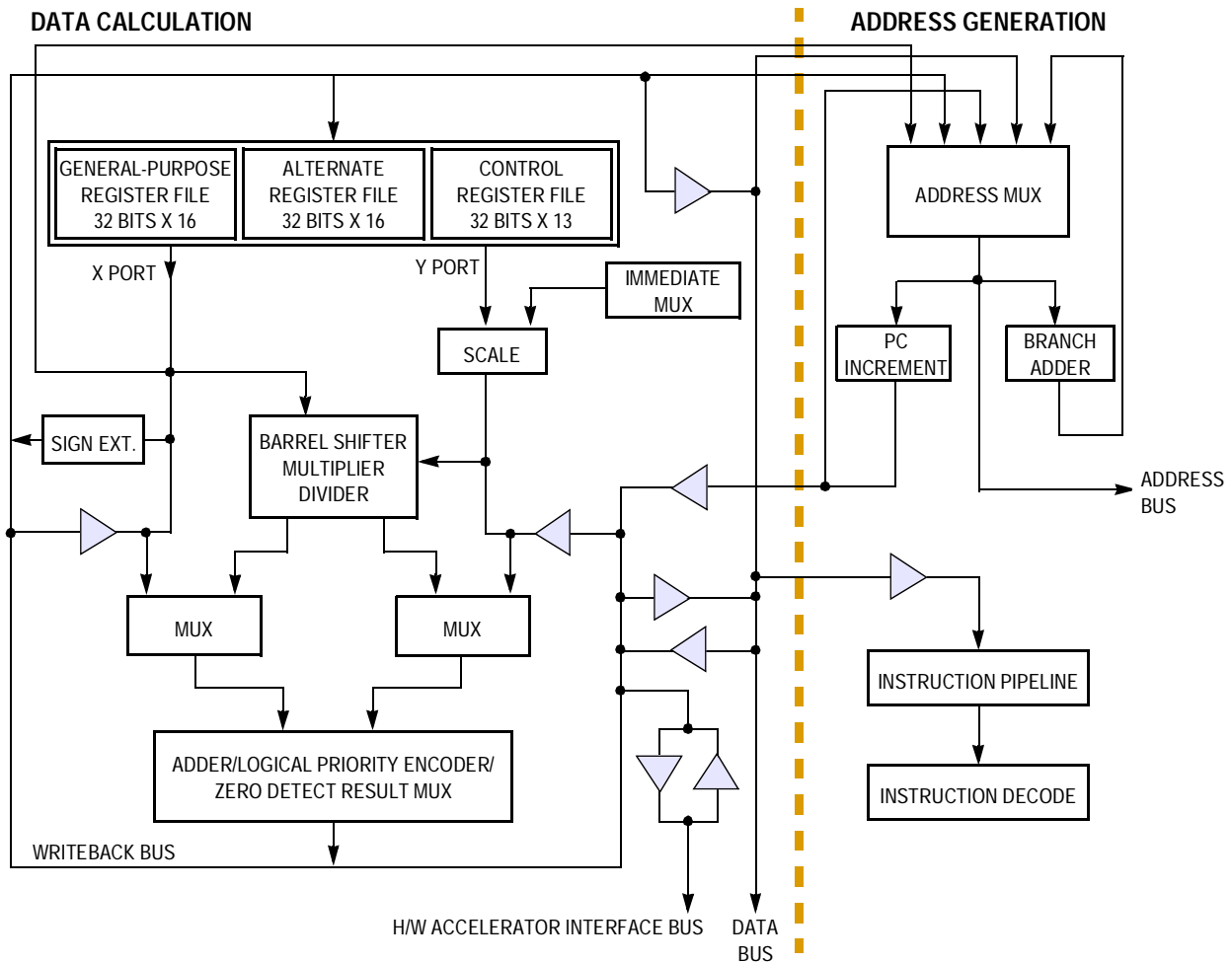

**Figure 7-1. M•CORE Processor Block Diagram**

Arithmetic and logical operations are executed in a single cycle. Multiplication is implemented with a 2-bit per clock, overlapped-scan, modified Booth algorithm with early-out capability, to reduce execution time for operations with small multipliers. Divide is implemented with a 1-bit per clock early-in algorithm. The find-first-one unit operates in one clock cycle.

The program counter unit incorporates a dedicated branch address adder to minimize delays during change of flow operations. Branch target addresses are calculated in parallel with branch instruction decode. Taken branches and jumps require only two clocks; branches which are not taken execute in one clock cycle.

Memory load and store operations are provided for 8-bit (byte), 16-bit (halfword), and 32-bit (word) data, with automatic zero extension for byte and half-word load operations. These instructions can execute in as few as two clock cycles. Load and store multiple register instructions allow low overhead context save and restore operations. These instructions can execute in (N+1) clock cycles, where N is the number of registers to transfer.

A condition code/carry (C) bit is provided for condition testing or for use in implementing arithmetic and logical operations with operands/results greater than 32 bits. The C bit is typically set by explicit test/comparison operations, not as a side-effect of normal instruction operation. Exceptions to this rule occur for specialized operations where it is desirable to combine condition setting with actual computation.

The processor uses autovectors for both normal and fast interrupt requests. Fast interrupts take precedence over normal interrupts. Both types have dedicated exception shadow registers. For service requests of either kind, an automatic vector is generated when the request is made.



## 7.5 Programming Model

**Figure 7-2** shows the M•CORE processor programming model. The model is defined differently for supervisor and user privilege modes. By convention, in both modes R15 serves as the link register for subroutine calls. R0 is typically used as the stack pointer.

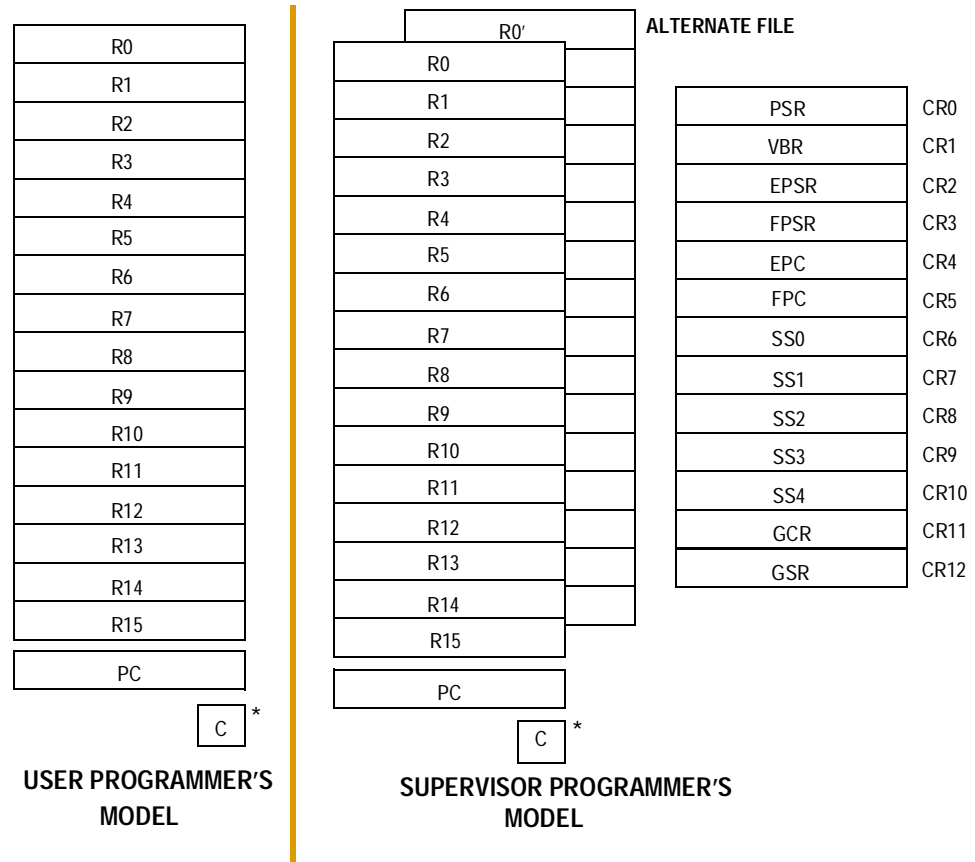

\* BIT 0 OF PSR

**Figure 7-2. Programming Model**

The user programming model consists of 16 general-purpose 32-bit registers (R0–R15), the 32-bit PC, and the C bit. The C bit is implemented as bit 0 of the Processor Status Register (PSR) and is the only portion of the PSR accessible in the user model.

The supervisor programming model consists of the user model plus 16 additional 32-bit general-purpose registers (R0–R15), called the alternate file and a set of status/control registers (CR0–CR12) which includes the entire PSR. Setting the S bit in the PSR enables supervisor mode operation.

The alternate file allows very low overhead context switching for real-time event handling. While the alternate file is enabled, general-purpose registers are accessed from it.

The Vector Base Register (VBR) determines the base address of the exception vector table. Exception shadow registers EPC and EPSR are used to save the states of the program counter and PSR, respectively, when an exception occurs. Shadow registers FPC and FPSR save the states of the program counter and PSR, respectively, when a fast interrupt exception occurs.

Five scratch registers (SS0–SS4) are used to handle exception events.

The global control (GCR) and status (GSR) registers can be used for a variety of system monitoring tasks at the discretion of the compiler used. They serve no specific function by or for the CPU.

## 7.6 Data Format Summary

The operand data formats supported by the integer unit are standard two's-complement data formats. The operand size for each instruction is either explicitly encoded in the instruction (load/store instructions) or implicitly defined by the instruction operation (index operations, byte extraction). Typically, instructions operate on all 32 bits of the source operand(s) and generate a 32-bit result.

Memory is viewed from a big-endian byte ordering perspective. The most significant byte (byte 0) of word 0 is located at address 0. Bits are numbered within a word starting with bit 31 as the most significant bit.

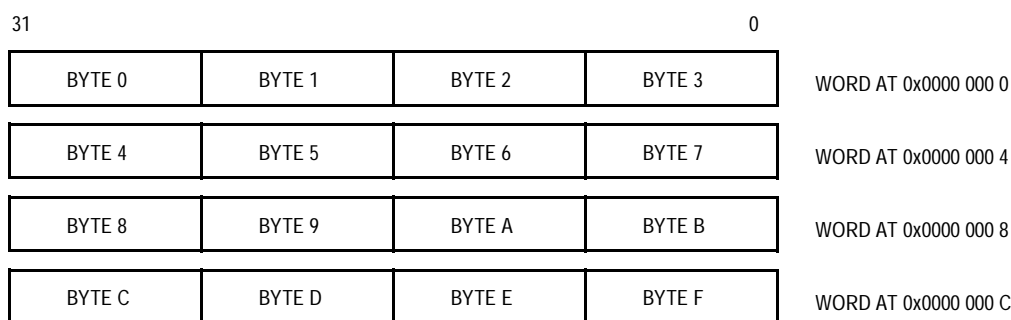

**Figure 7-3. Data Organization in Memory**

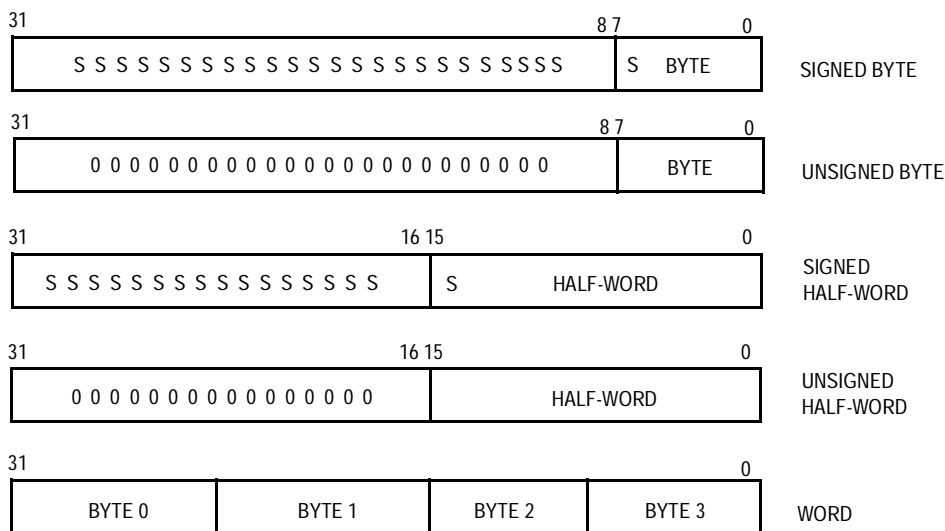

**Figure 7-4. Data Organization in Registers**

## 7.7 Operand Addressing Capabilities

The M•CORE processor accesses all memory operands through load and store instructions, transferring data between the general-purpose registers and memory. Register-plus-four-bit scaled displacement addressing mode is used for load and store instructions addressing byte, half-word, and word data.

Load and store multiple instructions allow a subset of the 16 general-purpose registers to be transferred to or from a base address pointed to by register R0 (the default stack pointer by convention).

Load and store register quadrant instructions use register indirect addressing to transfer a register quadrant to or from memory.

## 7.8 Instruction Set Overview

The instruction set is tailored to support high-level languages and is optimized for those instructions most commonly executed. A standard set of arithmetic and logical instructions is provided, as well as instruction support for bit operations, byte extraction, data movement, control flow modification, and a small set of conditionally executed instructions which can be useful in eliminating short conditional branches.

**Table 7-1** is an alphabetized listing of the M•CORE instruction set. Refer to the *M•CORE Reference Manual* (Motorola document order number MCORERM/AD) for more details on instruction operation.

**Table 7-1. M•CORE Instruction Set (Sheet 1 of 3)**

Mnemonic	Description	Execution Time (Cycles)
ABS	Absolute Value	1
ADDC	Add with C Bit	1
ADDI	Add Immediate	1
ADDU	Add Unsigned	1
AND	Logical AND	1
ANDI	Logical AND Immediate	1
ANDN	AND NOT	1
ASR	Arithmetic Shift Right	1
ASRC	Arithmetic Shift Right, Update C Bit	1
BCLRI	Bit Clear Immediate	1
BF	Branch on Condition False	1/2 <sup>(1)</sup>
BGENI	Bit Generate Immediate	1
BGENR	Bit Generate Register	1
BKPT	Breakpoint	Indet <sup>(2)</sup>
BMASKI	Bit Mask Immediate	1/2 <sup>(1)</sup>
BR	Branch	1
BREV	Bit Reverse	1
BSETI	Bit Set Immediate	1/2 <sup>(1)</sup>
BSR	Branch to Subroutine	1/2 <sup>(1)</sup>
BT	Branch on Condition True	1/2 <sup>(1)</sup>
BTSTI	Bit Test Immediate	1
CLRF	Clear Register on Condition False	1
CLRT	Clear Register on Condition True	1
CMPHS	Compare Higher or Same	1
CMPLT	Compare Less Than	1
CMPLTI	Compare Less Than Immediate	1
CMPNE	Compare Not Equal	1
CMPNEI	Compare Not Equal Immediate	1
DECF	Decrement on Condition False	1
DECGT	Decrement Register and Set Condition if Result Greater Than Zero	1
DECLT	Decrement Register and Set Condition if Result Less Than Zero	1
DECNE	Decrement Register and Set Condition if Result Not Equal to Zero	1
DECT	Decrement on Condition True	1
DIVS	Divide Signed Integer	3–37 <sup>(3)</sup>
DIVU	Divide Unsigned Integer	3–37 <sup>(3)</sup>
DOZE	Doze	Indet <sup>(2)</sup>
FF1	Find First One	1
INCF	Increment on Condition False	1
INCT	Increment on Condition True	1
IXH	Index Half-Word	1
IXW	Index Word	1

**M•CORE M210 Central Processor Unit (CPU)**
**Table 7-1. M•CORE Instruction Set (Sheet 2 of 3)**

Mnemonic	Description	Execution Time (Cycles)
JMP	Jump	2
JMPI	Jump Indirect	3
JSR	Jump to Subroutine	2
JSRI	Jump to Subroutine Indirect	3
LD.[BHW]	Load	2
LDM	Load Multiple Registers	n+1 <sup>(4)</sup>
LDQ	Load Register Quadrant	5
LOOPT	Decrement with C-Bit Update and Branch if Condition True	1/2 <sup>(1)</sup>
LRW	Load Relative Word	2
LSL, LSR	Logical Shift Left and Right	1
LSLC, LSRC	Logical Shift Left and Right, Update C Bit	1
LSLI, LSRI	Logical Shift Left and Right by Immediate	1
MFCR	Move from Control Register	2
MOV	Move	1
MOVI	Move Immediate	1
MOVF	Move on Condition False	1
MOVT	Move on Condition True	1
MTCR	Move to Control Register	2
MULT	Multiply	3–18 <sup>(3)</sup>
MVC	Move C Bit to Register	1
MVCV	Move Inverted C Bit to Register	1
NOT	Logical Complement	1
OR	Logical Inclusive-OR	1
ROTLI	Rotate Left by Immediate	1
RSUB	Reverse Subtract	1
RSUBI	Reverse Subtract Immediate	1
RTE	Return from Exception	3
RFI	Return from Interrupt	3
SEXTB	Sign-Extend Byte	1
SEXTH	Sign-Extend Half-Word	1
ST.[BHW]	Store	2
STM	Store Multiple Registers	n+1 <sup>(4)</sup>
STQ	Store Register Quadrant	5
STOP	Stop	Indet <sup>(2)</sup>
SUBC	Subtract with C Bit	1
SUBU	Subtract	1
SUBI	Subtract Immediate	1
SYNC	Synchronize	1
TRAP	Trap	5
TST	Test Operands	1
TSTNBZ	Test for No Byte Equal Zero	1
WAIT	Wait	Indet <sup>(2)</sup>

**Table 7-1. M•CORE Instruction Set (Sheet 3 of 3)**

Mnemonic	Description	Execution Time (Cycles)
XOR	Exclusive OR	1
XSR	Extended Shift Right	1
XTRB0	Extract Byte 0	1
XTRB1	Extract Byte 1	1
XTRB2	Extract Byte 2	1
XTRB3	Extract Byte 3	1
ZEXTB	Zero-Extend Byte	1
ZEXTH	Zero-Extend Half-Word	1

1. 1 cycle if branch not taken, 2 cycles if branch taken
2. Execution time of BKPT, DOZE, WAIT, and STOP is 1 cycle but execution does not take place until all current bus transactions have completed.
3. Cycle time is dependent upon magnitude of result.
4. Number of cycles is equal to number of registers loaded/stored plus 1.





## Section 8. Interrupt Controller Module

### 8.1 Contents

8.2	Introduction .....	178
8.3	Features .....	178
8.4	Low-Power Mode Operation .....	178
8.5	Block Diagram .....	179
8.6	External Signals .....	179
8.7	Memory Map and Registers .....	179
8.7.1	Memory Map .....	180
8.7.2	Registers .....	181
8.7.2.1	Interrupt Control Register .....	181
8.7.2.2	Interrupt Status Register .....	183
8.7.2.3	Interrupt Force Registers .....	184
8.7.2.4	Interrupt Pending Register .....	186
8.7.2.5	Normal Interrupt Enable Register .....	187
8.7.2.6	Normal Interrupt Pending Register .....	188
8.7.2.7	Fast Interrupt Enable Register .....	189
8.7.2.8	Fast Interrupt Pending Register .....	190
8.7.2.9	Priority Level Select Registers .....	191
8.8	Functional Description .....	191
8.8.1	Interrupt Sources and Prioritization .....	192
8.8.2	Fast and Normal Interrupt Requests .....	192
8.8.3	Autovector and Vectored Interrupt Requests .....	193
8.8.4	Interrupt Configuration .....	195
8.8.4.1	CPU Configuration .....	195
8.8.4.2	Interrupt Controller Configuration .....	195
8.8.4.3	Interrupt Source Configuration .....	196
8.8.5	Interrupts .....	196

## 8.2 Introduction

The interrupt controller collects requests from multiple interrupt sources and provides an interface to the CPU interrupt logic.

## 8.3 Features

Features of the interrupt controller module include:

- Up to 40 interrupt sources
- 32 unique programmable priority levels for each interrupt source
- Independent enable/disable of pending interrupts based on priority level
- Select normal or fast interrupt request for each priority level
- Fast interrupt requests always have priority over normal interrupts
- Ability to mask interrupts at and below a defined priority level
- Ability to select between autovectored or vectored interrupt requests
- Vectored interrupts generated based on priority level
- Ability to generate a separate vector number for normal and fast interrupts
- Ability for software to self-schedule interrupts
- Software visibility of pending interrupts and interrupt signals to core
- Asynchronous operation to support wakeup from low-power modes

## 8.4 Low-Power Mode Operation

The interrupt controller is not affected by any low-power modes. All logic between the input sources and generating the raw interrupt to the CPU is combinational. This allows the CPU to wake up during low-power stop mode when all system clocks are stopped.

### 8.5 Block Diagram

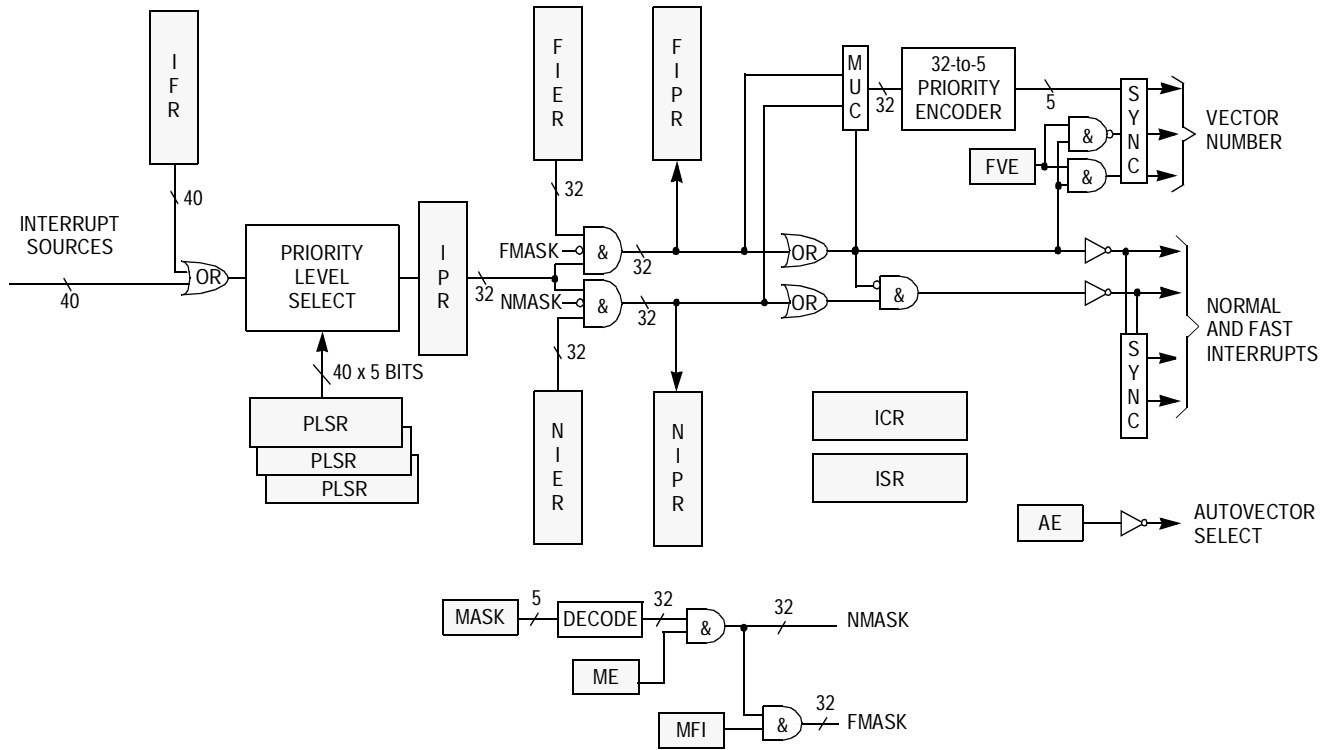

Figure 8-1. Interrupt Controller Block Diagram

### 8.6 External Signals

No interrupt controller signals connect off-chip.

### 8.7 Memory Map and Registers

This subsection describes the memory map (see [Table 8-1](#)) and registers.

**Interrupt Controller Module**
**8.7.1 Memory Map**
**Table 8-1. Interrupt Controller Module Memory Map**

Address	Bits 31–24	Bits 23–16	Bits 15–8	Bits 7–0	Access <sup>(1)</sup>
0x00c5_0000	Interrupt Control Register (ICR)		Interrupt Status Register (ISR)		S/U
0x00c5_0004	Interrupt Force Register High (IFRH)				S/U
0x00c5_0008	Interrupt Force Register Low (IFRL)				S/U
0x00c5_000c	Interrupt Pending Register (IPR)				S/U
0x00c5_0010	Normal Interrupt Enable Register (NIER)				S/U
0x00c5_0014	Normal Interrupt Pending Register (NIPR)				S/U
0x00c5_0018	Fast Interrupt Enable Register (FIER)				S/U
0x00c5_001c	Fast Interrupt Pending Register (FIPR)				S/U
0x00c5_0020 through 0x00c5_003c	Unimplemented <sup>(2)</sup>				—
Priority Level Select Registers (PLSR0–PLSR39)					
0x00c5_0040	PLSR0	PLSR1	PLSR2	PLSR3	S
0x00c5_0044	PLSR4	PLSR5	PLSR6	PLSR7	S
0x00c5_0048	PLSR8	PLSR9	PLSR10	PLSR11	S
0x00c5_004c	PLSR12	PLSR13	PLSR14	PLSR15	S
0x00c5_0050	PLSR16	PLSR17	PLSR18	PLSR19	S
0x00c5_0054	PLSR20	PLSR21	PLSR22	PLSR23	S
0x00c5_0058	PLSR24	PLSR25	PLSR26	PLSR27	S
0x00c5_005c	PLSR28	PLSR29	PLSR30	PLSR31	S
0x00c5_0060	PLSR32	PLSR33	PLSR34	PLSR35	S
0x00c5_0064	PLSR36	PLSR37	PLSR38	PLSR39	S
0x00c5_0068 through 0x00c5_007c	Unimplemented <sup>(2)</sup>				—

1. S = CPU supervisor mode access only. S/U = CPU supervisor or user mode access. User mode accesses to supervisor only addresses have no effect and result in a cycle termination transfer error.
2. Accesses to unimplemented address locations have no effect and result in a cycle termination transfer error.

## 8.7.2 Registers

This subsection contains a description of the interrupt controller module register set.

### 8.7.2.1 Interrupt Control Register

The 16-bit Interrupt Control Register (ICR) selects whether interrupt requests are autovectored or vectored, and if vectored, whether fast interrupts generate a different vector number than normal interrupts. This register also controls the masking functions.

Address: 0x00c5\_0000 and 0x00c5\_0001

	Bit 15	14	13	12	11	10	9	Bit 8
Read:	AE	FVE	ME	MFI	0	0	0	0
Write:								
Reset:	1	0	0	0	0	0	0	0
	Bit 7	6	5	4	3	2	1	Bit 0
Read:	0	0	0	MASK4	MASK3	MASK2	MASK1	MASK0
Write:								
Reset:	0	0	0	0	0	0	0	0

= Writes have no effect and the access terminates without a transfer error exception.

**Figure 8-2. Interrupt Control Register (ICR)**

#### AE — Autovector Enable Bit

The read/write AE bit enables fast and normal autovectored interrupt requests. Reset sets AE.

- 1 = Autovectored interrupt requests
- 0 = Vectored interrupt requests

#### FVE — Fast Vector Enable Bit

The read/write FVE bit enables fast vectored interrupt requests to have vector numbers separate from normal vectored interrupt requests. Reset clears FVE.

- 1 = Unique vector numbers for fast vectored interrupt requests
- 0 = Same vector number for fast and normal vectored interrupt requests

**ME — Mask Enable Bit**

The read/write ME bit enables interrupt masking. Reset clears ME.

- 1 = Interrupt masking enabled
- 0 = Interrupt masking disabled

**MFI — Mask Fast Interrupts Bit**

The read/write MFI bit enables masking of fast interrupt requests. Reset clears MFI.

- 1 = Fast interrupt requests masked by MASK value. All normal interrupt requests are masked.
- 0 = Fast interrupt requests are not masked regardless of the MASK value. The MASK only applies to normal interrupts. Reset clears MFI.

**MASK[4:0] — Interrupt Mask Field**

The read/write MASK[4:0] field determines which interrupt priority levels are masked. When the ME bit is set, all pending interrupt requests at priority levels at and below the current MASK value are masked. To mask all normal interrupts without masking any fast interrupts, set the MASK value to 31 with the MFI bit cleared. See [Table 8-2](#). Reset clears MASK[4:0].

**Table 8-2. MASK Encoding**

MASK[4:0]		Masked Priority Levels
Decimal	Binary	
0	00000	0
1	00001	1–0
2	00010	2–0
3	00011	3–0
•	•	•
•	•	•
•	•	•
31	11111	31–0

### 8.7.2.2 Interrupt Status Register

The 16-bit, read-only Interrupt Status Register (ISR) reflects the state of the interrupt controller outputs to the CPU. Writes to this register have no effect and are terminated normally.

Address: 0x00c5\_0002 and 0x00c5\_0003

	Bit 15	14	13	12	11	10	9	Bit 8
Read:	0	0	0	0	0	0	INT	FINT
Write:								
Reset:	0	0	0	0	0	0	0	0
	Bit 7	6	5	4	3	2	1	Bit 0
Read:	0	VEC6	VEC5	VEC4	VEC3	VEC2	VEC1	VEC0
Write:								
Reset:	0	0	0	0	0	0	0	0

= Writes have no effect and the access terminates without a transfer error exception.

**Figure 8-3. Interrupt Status Register (ISR)**

#### INT — Normal Interrupt Request Flag

The read-only INT flag indicates whether the normal interrupt request signal to the CPU is asserted or negated. Reset clears INT.

- 1 = Normal interrupt request asserted
- 0 = Normal interrupt request negated

#### FINT — Fast Interrupt Request Flag

The read-only FINT flag indicates whether the fast interrupt request signal to the CPU is asserted or negated. Reset clears FINT.

- 1 = Fast interrupt request asserted
- 0 = Fast interrupt request negated

#### VEC[6:0] — Interrupt Vector Number Field

The read-only VEC[6:0] field contains the 7-bit interrupt vector number (see [Table 8-5](#)). Reset clears VEC[6:0].

**Interrupt Controller Module**

8.7.2.3 Interrupt Force Registers

The two 32-bit read/write Interrupt Force Registers (IFRH and IFRL) individually force interrupt source requests.

Address: 0x00c5\_0004 through 0x00c5\_0007

	Bit 31	30	29	28	27	26	25	Bit 24
Read:	0	0	0	0	0	0	0	0
Write:								
Reset:	0	0	0	0	0	0	0	0
	Bit 23	22	21	20	19	18	17	Bit 16
Read:	0	0	0	0	0	0	0	0
Write:								
Reset:	0	0	0	0	0	0	0	0
	Bit 15	14	13	12	11	10	9	Bit 8
Read:	0	0	0	0	0	0	0	0
Write:								
Reset:	0	0	0	0	0	0	0	0
	Bit 7	6	5	4	3	2	1	Bit 0
Read:	IF39	IF38	IF37	IF36	IF35	IF34	IF33	IF32
Write:								
Reset:	0	0	0	0	0	0	0	0

 = Writes have no effect and the access terminates without a transfer error exception.

**Figure 8-4. Interrupt Force Register High (IFRH)**



Address: 0x00c5\_0008 through 0x00c5\_000b

	Bit 31	30	29	28	27	26	25	Bit 24
Read:	IF31	IF30	IF29	IF28	IF27	IF26	IF25	IF24
Write:								
Reset:	0	0	0	0	0	0	0	0
	Bit 23	22	21	20	19	18	17	Bit 16
Read:	IF23	IF22	IF21	IF20	IF19	IF18	IF17	IF16
Write:								
Reset:	0	0	0	0	0	0	0	0
	Bit 15	14	13	12	11	10	9	Bit 8
Read:	IF15	IF14	IF13	IF12	IF11	IF10	IF9	IF8
Write:								
Reset:	0	0	0	0	0	0	0	0
	Bit 7	6	5	4	3	2	1	Bit 0
Read:	IF7	IF6	IF5	IF4	IF3	IF2	IF1	IF0
Write:								
Reset:	0	0	0	0	0	0	0	0

**Figure 8-5. Interrupt Force Register Low (IFRL)**

**IF[39:0] — Interrupt Force Field**

This read/write field forces interrupt requests at the corresponding source numbers. Reference [Table 8-6](#) for interrupt source numbers to determine which bit(s) to set in this register. IFRH and IFRL allow software generation of interrupt requests for functional or debug purposes. Writing 0 to an IF bit negates the interrupt request. Reset clears the IF[39:0] field.

- 1 = Force interrupt request
- 0 = Interrupt source not forced

**Interrupt Controller Module**

8.7.2.4 Interrupt Pending Register

The 32-bit, read-only Interrupt Pending Register (IPR) reflects any currently pending interrupts which are assigned to each priority level. Writes to this register have no effect and are terminated normally.

Address: 0x00c5\_000c through 0x00c5\_000f

	Bit 31	30	29	28	27	26	25	Bit 24
Read:	IP31	IP30	IP29	IP28	IP27	IP26	IP25	IP24
Write:								
Reset:	0	0	0	0	0	0	0	0
	Bit 23	22	21	20	19	18	17	Bit 16
Read:	IP23	IP22	IP21	IP20	IP19	IP18	IP17	IP16
Write:								
Reset:	0	0	0	0	0	0	0	0
	Bit 15	14	13	12	11	10	9	Bit 8
Read:	IP15	IP14	IP13	IP12	IP11	IP10	IP9	IP8
Write:								
Reset:	0	0	0	0	0	0	0	0
	Bit 7	6	5	4	3	2	1	Bit 0
Read:	IP7	IP6	IP5	IP4	IP3	IP2	IP1	IP0
Write:								
Reset:	0	0	0	0	0	0	0	0

= Writes have no effect and the access terminates without a transfer error exception.

**Figure 8-6. Interrupt Pending Register (IPR)**

IP[31:0] — Interrupt Pending Field

A read-only IPx bit is set when at least one interrupt request is asserted at priority level x. Reset clears IP[31:0].

- 1 = At least one interrupt request asserted at priority level x
- 0 = All interrupt requests at level x negated

8.7.2.5 Normal Interrupt Enable Register

The read/write, 32-bit Normal Interrupt Enable Register (NIER) individually enables any current pending interrupts which are assigned to each priority level as a normal interrupt source. Enabling an interrupt source which has an asserted request causes that request to become pending, and a request to the CPU is asserted if not already outstanding.

Address: 0x00c5\_0010 through 0x00c5\_0013

	Bit 31	30	29	28	27	26	25	Bit 24
Read:	NIE31	NIE30	NIE29	NIE28	NIE27	NIE26	NIE25	NIE24
Write:	NIE31	NIE30	NIE29	NIE28	NIE27	NIE26	NIE25	NIE24
Reset:	0	0	0	0	0	0	0	0
	Bit 23	22	21	20	19	18	17	Bit 16
Read:	NIE23	NIE22	NIE21	NIE20	NIE19	NIE18	NIE17	NIE16
Write:	NIE23	NIE22	NIE21	NIE20	NIE19	NIE18	NIE17	NIE16
Reset:	0	0	0	0	0	0	0	0
	Bit 15	14	13	12	11	10	9	Bit 8
Read:	NIE15	NIE14	NIE13	NIE12	NIE11	NIE10	NIE9	NIE8
Write:	NIE15	NIE14	NIE13	NIE12	NIE11	NIE10	NIE9	NIE8
Reset:	0	0	0	0	0	0	0	0
	Bit 7	6	5	4	3	2	1	Bit 0
Read:	NIE7	NIE6	NIE5	NIE4	NIE3	NIE2	NIE1	NIE0
Write:	NIE7	NIE6	NIE5	NIE4	NIE3	NIE2	NIE1	NIE0
Reset:	0	0	0	0	0	0	0	0

**Figure 8-7. Normal Interrupt Enable Register (NIER)**

NIE[31:0] — Normal Interrupt Enable Field

The read/write NIE[31:0] field enables interrupt requests from sources at the corresponding priority level as normal interrupt requests. Reset clears NIE[31:0].

- 1 = Normal interrupt request enabled
- 0 = Normal interrupt request disabled

**Interrupt Controller Module**

8.7.2.6 Normal Interrupt Pending Register

The read-only, 32-bit Normal Interrupt Pending Register (NIPR) reflects any currently pending normal interrupts which are assigned to each priority level. Writes to this register have no effect and are terminated normally.

Address: 0x00c5\_0014 through 0x00c5\_0017

	Bit 31	30	29	28	27	26	25	Bit 24
Read:	NIP31	NIP30	NIP29	NIP28	NIP27	NIP26	NIP25	NIP24
Write:								
Reset:	0	0	0	0	0	0	0	0
	Bit 23	22	21	20	19	18	17	Bit 16
Read:	NIP23	NIP22	NIP21	NIP20	NIP19	NIP18	NIP17	NIP16
Write:								
Reset:	0	0	0	0	0	0	0	0
	Bit 15	14	13	12	11	10	9	Bit 8
Read:	NIP15	NIP14	NIP13	NIP12	NIP11	NIP10	NIP9	NIP8
Write:								
Reset:	0	0	0	0	0	0	0	0
	Bit 7	6	5	4	3	2	1	Bit 0
Read:	NIP7	NIP6	NIP5	NIP4	NIP3	NIP2	NIP1	NIP0
Write:								
Reset:	0	0	0	0	0	0	0	0

= Writes have no effect and the access terminates without a transfer error exception.

**Figure 8-8. Normal Interrupt Pending Register (NIPR)**

NIP[31:0] — Normal Interrupt Pending Field

A read-only NIPx bit is set when at least one normal interrupt request is asserted at priority level x. Reset clears NIP[31:0].

- 1 = At least one normal interrupt request asserted at priority level x
- 0 = All normal interrupt requests at priority level x negated

### 8.7.2.7 Fast Interrupt Enable Register

The read/write, 32-bit Fast Interrupt Enable Register (FIER) enables any current pending interrupts which are assigned at each priority level as a fast interrupt source. Enabling an interrupt source which has an asserted request causes that interrupt to become pending, and a request to the CPU is asserted if not already outstanding.

Address: 0x00c5\_0018 through 0x00c5\_001b

	Bit 31	30	29	28	27	26	25	Bit 24
Read:	FIE31	FIE30	FIE29	FIE28	FIE27	FIE26	FIE25	FIE24
Write:	FIE31	FIE30	FIE29	FIE28	FIE27	FIE26	FIE25	FIE24
Reset:	0	0	0	0	0	0	0	0
	Bit 23	22	21	20	19	18	17	Bit 16
Read:	FIE23	FIE22	FIE21	FIE20	FIE19	FIE18	FIE17	FIE16
Write:	FIE23	FIE22	FIE21	FIE20	FIE19	FIE18	FIE17	FIE16
Reset:	0	0	0	0	0	0	0	0
	Bit 15	14	13	12	11	10	9	Bit 8
Read:	FIE15	FIE14	FIE13	FIE12	FIE11	FIE10	FIE9	FIE8
Write:	FIE15	FIE14	FIE13	FIE12	FIE11	FIE10	FIE9	FIE8
Reset:	0	0	0	0	0	0	0	0
	Bit 7	6	5	4	3	2	1	Bit 0
Read:	FIE7	FIE6	FIE5	FIE4	FIE3	FIE2	FIE1	FIE0
Write:	FIE7	FIE6	FIE5	FIE4	FIE3	FIE2	FIE1	FIE0
Reset:	0	0	0	0	0	0	0	0

**Figure 8-9. Fast Interrupt Enable Register (FIER)**

#### FIE[31:0] — Fast Interrupt Enable Field

The read/write FIE[31:0] field enables interrupt requests from sources at the corresponding priority level as fast interrupts. Reset clears FIE[31:0].

- 1 = Fast interrupt enabled
- 0 = Fast interrupt disabled

**Interrupt Controller Module**

8.7.2.8 Fast Interrupt Pending Register

The read-only, 32-bit Fast Interrupt Pending Register (FIPR) reflects any currently pending fast interrupts which are assigned to each priority level. Writes to this register have no effect and are terminated normally.

Address: 0x00c5\_001c through 0x00c5\_001f

	Bit 31	30	29	28	27	26	25	Bit 24
Read:	FIP31	FIP30	FIP29	FIP28	FIP27	FIP26	FIP25	FIP24
Write:								
Reset:	0	0	0	0	0	0	0	0
	Bit 23	22	21	20	19	18	17	Bit 16
Read:	FIP23	FIP22	FIP21	FIP20	FIP19	FIP18	FIP17	FIP16
Write:								
Reset:	0	0	0	0	0	0	0	0
	Bit 15	14	13	12	11	10	9	Bit 8
Read:	FIP15	FIP14	FIP13	FIP12	FIP11	FIP10	FIP9	FIP8
Write:								
Reset:	0	0	0	0	0	0	0	0
	Bit 7	6	5	4	3	2	1	Bit 0
Read:	FIP7	FIP6	FIP5	FIP4	FIP3	FIP2	FIP1	FIP0
Write:								
Reset:	0	0	0	0	0	0	0	0

 = Writes have no effect and the access terminates without a transfer error exception.

**Figure 8-10. Fast Interrupt Pending Register (FIPR)**

FIP[31:0] — Fast Interrupt Pending Field

A read-only FIP[x] bit is set when at least one interrupt request at priority level x is pending and enabled as a fast interrupt. Reset clears FIP[31:0].

- 1 = At least one fast interrupt request asserted at priority level x
- 0 = Any fast interrupt requests at priority level x negated

### 8.7.2.9 Priority Level Select Registers

The read/write 8-bit Priority Level Select Registers (PLSRx) are 40 read/write, 8-bit priority level select registers PLSR0–PLSR39, one for each of the interrupt source. The PLSRx register assigns a priority level to interrupt source x.

Address: 0x00c5\_0040 through 0x00c5\_0067

	Bit 7	6	5	4	3	2	1	Bit 0
Read:	0	0	0	PLS4	PLS3	PLS2	PLS1	PLS0
Write:				PLS4	PLS3	PLS2	PLS1	PLS0
Reset:	0	0	0	0	0	0	0	0

= Writes have no effect and the access terminates without a transfer error exception.

**Figure 8-11. Priority Level Select Registers (PLSR0–PLSR39)**

#### PLS[4:0] — Priority Level Select Field

The PLS[4:0] field assigns a priority level from 0 to 31 to the corresponding interrupt source. Reset clears PLS[4:0].

**Table 8-3. Priority Select Encoding**

PLS[4:0]	Priority Level	Vector Number
00000	0 (lowest)	00000
00001–11110	1–30	00001–11110
11111	31 (highest)	11111

## 8.8 Functional Description

The interrupt controller collects interrupt requests from multiple interrupt sources and provides an interface to the CPU interrupt logic. Interrupt controller functions include:

- Interrupt source prioritization
- Fast and normal interrupt requests
- Autovectored and vectored interrupt requests
- Interrupt configuration

### 8.8.1 Interrupt Sources and Prioritization

Each interrupt source in the system sends a unique signal to the interrupt controller. Up to 40 interrupt sources are supported. Each interrupt source can be programmed to one of 32 priority levels by programming the PLS bits of the PLSR in the interrupt controller. The highest priority level is 31 and lowest priority level is 0. By default, each interrupt source is assigned to the priority level 0. Each interrupt source is associated with a 5-bit priority level select value that selects one of 32 priority levels. The interrupt controller uses the priority levels as the basis for the generation of all interrupt signals to the CPU.

Interrupt requests may be forced by software by writing to IFRH and IFRL. Each bit of IFRH and IFRL is logically ORed with the corresponding interrupt source signal before the priority level select logic. To negate the forced interrupt request, the interrupt handler can clear the appropriate IFR bit. IPR reflects the state of each priority level.

### 8.8.2 Fast and Normal Interrupt Requests

FIER allows individual enabling or masking of pending fast interrupt requests. FIER is logically ANDed with IPR, and the result is stored in FIPR. FIPR bits are bit-wise ORed together and inverted to form the fast interrupt signal routed to the CPU (see [Figure 8-1](#)). The FIPR allows software to quickly determine the highest priority pending fast interrupt. The output of FIPR also feeds into a 32-to-5 priority encoder to generate the vector number to present to the CPU if vectored interrupts are required.

NIER allows individual enabling or masking of pending normal interrupt requests. NIER is logically ANDed with IPR, and the result is stored in NIPR. NIPR bits are bit-wise ORed together and inverted to form the normal interrupt signal routed to the CPU. The normal interrupt signal is only asserted if the fast interrupt signal is negated. The NIPR allows software to quickly determine the highest priority pending normal interrupt. The output of NIPR also feeds into a 32-to-5 priority encoder to generate the vector number to present to the CPU if vectored interrupts are required. If the fast interrupt signal is asserted, then the vector number is determined by the highest priority fast interrupt.



If an interrupt is pending at a given priority level and both the corresponding FIER and NIER bits are set, then both the corresponding FIPR and NIPR bits are set, assuming these bits are not masked.

Fast interrupt requests always have priority over normal interrupt requests, even if the normal interrupt request is at a higher priority level than the highest fast interrupt request.

If the fast interrupt signal is asserted when the normal interrupt signal is already asserted, then the normal interrupt signal is negated.

IPR, NIPR, and FIPR are read-only. To clear a pending interrupt, the interrupt must be cleared at the source using a special clearing sequence defined by each source. All interrupt sources to the interrupt controller are to be held until recognized and cleared by the interrupt service routine. The interrupt controller does not have any edge-detect logic. Edge-triggered interrupt sources are handled at the source module.

In ICR, the MASK[4:0] bits can mask interrupt sources at and below a selected priority level. The MFI bit determines whether the mask applies only to normal interrupts or to fast interrupts with all normal interrupts being masked. The ME bit enables interrupt masking.

ISR reflects the current vector number and the states of the signals to the CPU.

The vector number and fast/normal interrupt sources are synchronized before being sent to the CPU. Thus, the interrupt controller adds one clock of latency to the interrupt sequence. The fast and normal interrupt raw sources are not synchronized and are used to wake up the CPU during stop mode.

### 8.8.3 Autovectored and Vectored Interrupt Requests

The AE bit in ICR enables autovectored interrupt requests to the CPU. AE is set by default, and all interrupt requests are autovectored. An interrupt handler may read FIPR or NIPR to determine the priority of the interrupt source. If multiple interrupt sources share the same priority

level, then it is up to the interrupt service routine to determine the correct source of the interrupt.

If the AE bit is 0, then each interrupt request is presented with a vector number. The low five bits of the vector number (4–0) are determined based on the highest pending priority, with active fast interrupts having priority over active normal interrupts. The remaining two bits (vector bits 5 and 6) are determined based on whether the interrupt request is a fast interrupt and the setting of the FVE bit. If FVE is set, then a fast interrupt request has a vector number different from that of a normal interrupt request as shown in [Table 8-4](#).

**Table 8-4. Fast Interrupt Vector Number**

Fast Interrupt	FVE	Interrupt Vector Bits 6:5
No	X	01
X	0	01
Yes	1	10

If FVE is 0, both normal and fast interrupts have the same vector and requests assigned to priority levels 0–31 are mapped to vector numbers 32–63 in the vector table.

If FVE is 1, normal interrupt requests assigned to priority levels 0–31 are mapped to vector numbers 32–63 and fast interrupt requests assigned to priority levels 0–31 are mapped to vector numbers 64–95 in the vector table. See [Table 8-5](#).

**Table 8-5. Vector Table Mapping**

Vector Number	Usage	Interrupt Vector Bits 6:5
0–31	Fixed exceptions (including autovectors)	00
32–63	Normal only (FVE = 1) or normal/fast (FVE = 0) vectored interrupts 32 = lowest priority 63 = highest priority	01
64–95	Fast vectored interrupts (FVE = 1) 64 = lowest priority 95 = highest priority	10
96–127	Vectored interrupts (not used)	11

## 8.8.4 Interrupt Configuration

After reset, all interrupts are disabled by default. To properly configure the system to handle interrupt requests, configuration must be performed at three levels:

- CPU
- Interrupt controller
- Local interrupt sources

Configure the CPU first, the interrupt controller second, and the local interrupt sources last.

### 8.8.4.1 CPU Configuration

For fast interrupts, set the FIE[x] bit in FIER in the CPU. For normal interrupts, set the NIE[x] bit. Both FIE and NIE are cleared at reset.

**NOTE:** *To allow long latency, multicycle instructions to be interrupted before completion, set the IC bit in the PSR.*

VBR in the CPU defines the base address of the exception vector table. If autovectors are to be used, then initialize the INT and FINT autovectors (vector numbers 10 and 11, respectively). If vectored interrupts are to be used, then initialize the vectored interrupts (vector numbers 32–63 and/or 64–95). Whether 32 or 64 vectors are required depends on whether the fast interrupts share vectors with the normal interrupt sources based on the FVE bit in the interrupt controller ICR.

For each vector number, create an interrupt service routine to service the interrupt, clear the local interrupt flag, and return from the interrupt routine.

### 8.8.4.2 Interrupt Controller Configuration

By default, each interrupt source to the interrupt controller is assigned a priority level of 0 and disabled. Each interrupt source can be programmed to one of 32 priority levels and enabled as either a fast or normal interrupt source. Also, the FVE and AE bits in ICR can be programmed to select autovectored/vectored interrupts and also

determine if the fast interrupt vector number is to be separate from the normal interrupt vector.

#### 8.8.4.3 Interrupt Source Configuration

Each module that is capable of generating an interrupt request has an interrupt request enable/disable bit. To allow the interrupt source to be asserted, set the local interrupt enable bit.

Once an interrupt request is asserted, the module keeps the source asserted until the interrupt service routine performs a special sequence to clear the interrupt flag. Clearing the flag negates the interrupt request.

#### 8.8.5 Interrupts

The interrupt controller assigns a number to each interrupt source, as [Table 8-6](#) shows.

**Table 8-6. Interrupt Source Assignment**

Source	Module	Flag	Source Description	Flag Clearing Mechanism
0	ADC	PF1	Queue 1 conversion pause	Write PF1 = 0 after reading PF1 = 1
1		CF1	Queue 1 conversion complete	Write CF1 = 0 after reading CF1 = 1
2		PF2	Queue 2 conversion pause	Write PF2 = 0 after reading PF2 = 1
3		CF2	Queue 2 conversion complete	Write CF2 = 0 after reading CF2 = 1
4	SPI	MODF	Mode fault	Write to SPICR1 after reading MODF = 1
5		SPIF	Transfer complete	Access SPIDR after reading SPIF = 1
6	SCI1	TDRE	Transmit Data Register empty	Write SCIDRL after reading TDRE = 1
7		TC	Transmit complete	Write SCIDRL after reading TC = 1
8		RDRF	Receive Data Register full	Read SCIDRL after reading RDRF = 1
9		OR	Receiver overrun	Read SCIDRL after reading OR = 1
10		IDLE	Receiver line idle	Read SCIDRL after reading IDLE = 1
11	SCI2	TDRE	Transmit Data Register empty	Write SCIDRL after reading TDRE = 1
12		TC	Transmit complete	Write SCIDRL after reading TC = 1
13		RDRF	Receive Data Register full	Read SCIDRL after reading RDRF = 1
14		OR	Receiver overrun	Read SCIDRL after reading OR = 1
15		IDLE	Receiver line idle	Read SCIDRL after reading IDLE = 1
16	TIM1	C0F	Timer channel 0	Write C0F = 1 or access IC/OC if TFFCA = 1
17		C1F	Timer channel 1	Write 1 to C1F or access IC/OC if TFFCA = 1
18		C2F	Timer channel 2	Write 1 to C2F or access IC/OC if TFFCA = 1
19		C3F	Timer channel 3	Write 1 to C3F or access IC/OC if TFFCA = 1
20		TOF	Timer overflow	Write TOF = 1 or access TIMCNTH/L if TFFCA = 1
21		PAIF	Pulse accumulator input	Write PAIF = 1 or access PAC if TFFCA = 1
22		PAOVF	Pulse accumulator overflow	Write PAOVF = 1 or access PAC if TFFCA = 1

Continued on next page

**Table 8-6. Interrupt Source Assignment (Continued)**

Source	Module	Flag	Source Description	Flag Clearing Mechanism
23	TIM2	C0F	Timer channel 0	Write C0F = 1 or access IC/OC if TFFCA = 1
24		C1F	Timer channel 1	Write C1F = 1 or access IC/OC if TFFCA = 1
25		C2F	Timer channel 2	Write C2F = 1 or access IC/OC if TFFCA = 1
26		C3F	Timer channel 3	Write C3F = 1 or access IC/OC if TFFCA = 1
27		TOF	Timer overflow	Write TOF = 1 or access TIMCNTH/L if TFFCA = 1
28		PAIF	Pulse accumulator input	Write PAIF = 1 or access PAC if TFFCA = 1
29		PAOVF	Pulse accumulator overflow	Write PAOVF = 1 or access PAC if TFFCA = 1
30	PIT1	PIF	PIT interrupt flag	Write PIF = 1 or write PMR
31	PIT2	PIF	PIT interrupt flag	Write PIF = 1 or write PMR
32	EPORT/ PMM <sup>(1)</sup>	EPF0/ LVDF	Edge port flag 0/LVD	Write EPF0 = 1/write LVDF = 1
33	EPORT/ SGFM <sup>(2)</sup>	EPF1 CBEIF/ CCIF	Edge port flag 1/SGFM buffer empty/SGFM command complete	Write EPF1 = 1/write CBEIF = 1; CCIF cleared automatically
34	EPORT	EPF2	Edge port flag 2	Write EPF2 = 1
35		EPF3	Edge port flag 3	Write EPF3 = 1
36		EPF4	Edge port flag 4	Write EPF4 = 1
37		EPF5	Edge port flag 5	Write EPF5 = 1
38		EPF6	Edge port flag 6	Write EPF6 = 1
39		EPF7	Edge port flag 7	Write EPF7 = 1

1. Interrupt source 32 is shared by INT0 of the EPORT and low voltage detect (LVD) of the power management module (PMM), a sub-module of the reset mode (see [Section 5. Reset Controller Module](#)).
2. Interrupt source 33 is shared by INT1 of the EPORT and two interrupts from the second generation FLASH for M•CORE (SGFM) module. See [10.7.2.5 SGFM User Status Register](#) for a description of the flags set when these two interrupts occur.

## Section 9. Static Random Access Memory (SRAM)

### 9.1 Contents

9.2	Introduction . . . . .	199
9.3	Modes of Operation . . . . .	200
9.4	Low-Power Modes . . . . .	200
9.5	Standby Power Supply Pin ( $V_{STBY}$ ) . . . . .	200
9.6	Standby Operation . . . . .	200
9.7	Reset Operation . . . . .	201
9.8	Interrupts. . . . .	201

### 9.2 Introduction

Features of the static random access memory (SRAM) include:

- On-chip 8-Kbyte SRAM (MMC2113) or on-chip 32-Kbyte SRAM (MMC2112 and MMC2114)
- Fixed address space
- Byte, half-word (16-bit), or word (32-bit) read/write accesses
- One clock per access (including bytes, half-words, and words)
- Supervisor or user mode access
- Standby power supply switch to support an external power supply

### 9.3 Modes of Operation

Access to the SRAM is not restricted in any way. The array can be accessed in supervisor and user modes.

**NOTE:** *The MMC2113 may contain more than 8K of internal SRAM, but only the 8K range from 0x0080\_0000 to 0x0080\_1fff is tested and guaranteed to be operational. It is recommended that internal SRAM outside this range not be used. Accesses to SRAM outside this range terminate without a transfer error exception.*

### 9.4 Low-Power Modes

In wait, doze, and stop modes, clocks to the SRAM are disabled. No recovery time is required when exiting these modes.

### 9.5 Standby Power Supply Pin ( $V_{STBY}$ )

The standby power supply pin ( $V_{STBY}$ ) provides standby voltage to the SRAM array if  $V_{DD}$  is lost.  $V_{STBY}$  is isolated from all other  $V_{DD}$  nodes.

### 9.6 Standby Operation

When the chip is powered down, the contents of the SRAM array are maintained by the standby power supply,  $V_{STBY}$ . If the standby voltage falls below the minimum required voltage, the SRAM contents may be corrupted. The SRAM automatically switches to standby operation with no loss of data when the voltage on  $V_{DD}$  is below the voltage on  $V_{STBY}$ . In standby mode, the SRAM does not respond to any bus cycles. Unexpected operation may occur if the central processor unit (CPU) requests data from the SRAM in standby mode. If standby operation is not needed, then the  $V_{STBY}$  pin should be connected to  $V_{DD}$ .

The current on  $V_{STBY}$  may exceed its specified maximum value at some time during the transition time during which  $V_{DD}$  is at or below the voltage switch threshold to a threshold above  $V_{SS}$ . If the standby power supply cannot provide enough current to maintain  $V_{STBY}$  above the



required minimum value, then a capacitor must be provided from  $V_{\text{STBY}}$  to  $V_{\text{SS}}$ . The value of the capacitor,  $C$ , can be calculated as:

$$C = I \times \frac{t}{V}$$

where:

$I$  is the difference between the transition current requirement and the maximum power supply current,

$t$  is the duration of the  $V_{\text{DD}}$  transition near the voltage switch threshold, and

$V$  is the difference between the minimum available supply voltage and the required minimum  $V_{\text{STBY}}$  voltage.

## 9.7 Reset Operation

The SRAM contents are undefined immediately following a power-on reset. SRAM contents are unaffected by system reset.

If a synchronous reset occurs during a read or write access, then the access completes normally and any pipelined access in progress is stopped without corruption of the SRAM contents.

## 9.8 Interrupts

The SRAM module does not generate interrupt requests.



## **Section 10. Second Generation FLASH for M•CORE (SGFM)**

### **10.1 Contents**

10.2	Introduction .....	204
10.3	Glossary .....	205
10.4	Features .....	206
10.5	Modes of Operation .....	206
10.6	Block Diagram .....	207
10.7	Module Memory Map .....	209
10.7.1	Unbanked Register Descriptions .....	213
10.7.1.1	SGFM Configuration Register .....	213
10.7.1.2	SGFM Clock Divider Register .....	215
10.7.1.3	SGFM Test Register .....	216
10.7.1.4	SGFM Security Register .....	217
10.7.1.5	SGFM Monitor Data Register .....	219
10.7.2	Banked Register Descriptions .....	220
10.7.2.1	SGFM Protection Register .....	220
10.7.2.2	SGFM Supervisor Access Register .....	222
10.7.2.3	SGFM Data Access Register .....	223
10.7.2.4	SGFM Test Status Register .....	224
10.7.2.5	SGFM User Status Register .....	224
10.7.2.6	SGFM Command Register .....	226
10.7.2.7	SGFM Control Register .....	227
10.7.2.8	SGFM Address Register .....	228
10.7.2.9	SGFM Data Register .....	229
10.8	SGFM User Mode .....	230
10.8.1	Read Operations .....	230
10.8.2	Write Operations .....	230

10.8.3	Program and Erase Operations . . . . .	231
10.8.3.1	Setting the SGFMCLKD Register. . . . .	231
10.8.3.2	Program, Erase, and Verify Sequences. . . . .	232
10.8.3.3	FLASH User Mode Valid Commands. . . . .	234
10.8.3.4	FLASH User Mode Illegal Operations . . . . .	236
10.8.4	Stop Mode . . . . .	237
10.8.5	Master Mode . . . . .	238
10.8.6	Emulation Mode . . . . .	238
10.8.7	Debug Mode. . . . .	238
10.9	FLASH Security Operation . . . . .	238
10.9.1	Back Door Access . . . . .	239
10.9.2	Erase Verify Check. . . . .	239
10.10	Resets. . . . .	240
10.11	Interrupts. . . . .	240

## 10.2 Introduction

The second generation FLASH for M•CORE (SGFM) is constructed with building blocks of 32,768 by 16 bits that can be used to generate 128-, 256-, 384- and 512-Kbyte electrically erasable and programmable read-only memory arrays using two, four, six, and eight blocks respectively. The SGFM is ideal for program and data storage for single-chip applications and allows for field reprogramming without external high-voltage sources.

The voltages required to program and erase the FLASH is generated internally by on-chip charge pumps. Program and erase operations are performed under CPU control through a command driven interface to an internal state machine. All FLASH physical blocks can be programmed or erased at the same time; however, it is not possible to read from a FLASH physical block while the same block is being programmed or erased. For 256-Kbyte and larger arrays, it is possible to program or erase one pair of FLASH physical blocks under the control of software routines executing out of another pair.

## 10.3 Glossary

**SGFM** — Second generation FLASH for M•CORE. Acronym used throughout this document to reference this module.

**SGFM Module** — Includes the bus interface, command controller, built-in self test (BIST) controller, and the FLASH physical blocks.

**FLASH Physical Block** — A 64-Kbyte FLASH hard block organized as 32,768 halfwords (32K x 16 bits) that includes high voltage generation and parametric test features.

**FLASH Logical Sector** — An 8-Kbyte sector of contiguous FLASH memory that can be protected from program and erase operations. A logical sector can have supervisor/user and program/data space access restrictions.

**FLASH Erase Page** — Eight rows of 64 bytes (512 bytes) in one FLASH physical block. Two pages, one from each interleaving physical block, are erased at one time.

**Banked Register** — A register that operates on two interleaved FLASH physical blocks. Banked registers share the same control register addresses as the equivalent registers for the other FLASH physical blocks. The active register bank is selected by a bank select field in the unbanked register space. The SGFM module contains one to four sets of banked registers depending on the size of the array.

**Unbanked Register** — A register which operates upon all FLASH physical blocks.

**Command Sequence** — A three step sequence to program, erase, or verify the FLASH.

**FLASH User Mode** — The mode in which the FLASH module operates when executing user code and software controlled program and erase operations.

**SATO** — Acronym used for sense amplifier timeout analog hard-macro block. The SATO saves power at low system clock frequencies by limiting the time during which sense amps are enabled.

**Erased State** — Bit state that reads as a 1.

**Programmed State** — Bit state that reads as a 0.

## 10.4 Features

Features of the SGFM include:

- 128- (MMC2113), 256- (MMC2114), 384-, or 512-Kbytes of FLASH memory
- 33 MHz single cycle reads of bytes, aligned halfwords (16 bits), and aligned words (32 bits)
- Automated program and erase operation
- Concurrent verify, program, and erase of all array blocks
- Read-while-write capability for 256-Kbyte and larger arrays
- Optional interrupt on command completion
- Flexible scheme for protection against accidental program or erase operations
- Access restriction controls for both supervisor/user and data/program space operations
- Security for single-chip applications
- Single power supply (system  $V_{DD}$ ) used for all module operations
- Auto sense amplifier timeout for low-power, low-frequency read operations

## 10.5 Modes of Operation

The SGFM has two operating modes:

1. FLASH User Mode — In this mode, the SGFM is used for non-volatile program and data storage. FLASH program and erase operations are controlled by user software.
2. FLASH Test Mode — This is used at the factory only to test the SGFM.

Refer to [10.8 SGFM User Mode](#) for a description of FLASH user mode operations.

## 10.6 Block Diagram

The SGFM module shown in [Figure 10-1](#) contains the FLASH physical blocks, the M•CORE local bus (MLB) and IP bus interfaces, FLASH interface, register blocks, and the BIST engine.

Each 64-Kbyte FLASH physical block is arranged as 32,768 halfwords (16 bits) and may be read as either bytes or aligned halfwords. Aligned word access is provided by concatenating the outputs of two FLASH physical blocks. Reads of bytes, aligned halfwords, and aligned words require one clock cycle. Misaligned read accesses are not supported and will result in a cycle termination transfer error.

All FLASH program, erase, and verify commands operate on adjacent FLASH physical blocks and are initiated with a single aligned 32-bit write to the appropriate array location. Any other write operation will cause a cycle termination transfer error. For erase purposes, a FLASH physical block is organized as 1024 rows of 64 bytes with a single erase page consisting of 8 rows (512 bytes). Page erase operates simultaneously on two interleaving erase pages in adjacent FLASH physical blocks, making the minimum effective erase size 1 Kbyte. Mass erase operates simultaneously on two adjacent FLASH physical blocks in their entirety and erases a total of 128 Kbytes of array space.

Each pair of FLASH physical blocks requires a banked set of registers to control program and erase operations. [Figure 10-1](#) shows a 512-Kbyte module configured with four sets of banked registers. A 128 K-byte module would only require one set, a 256-Kbyte module would require two sets and a 384-Kbyte module would require three sets of banked registers.

An erased FLASH bit reads 1 and a programmed FLASH bit reads 0. The SGFM features a sense amplifier timeout block that automatically reduces current consumption during reads at low clock frequencies.

Second Generation FLASH for M•CORE (SGFM)

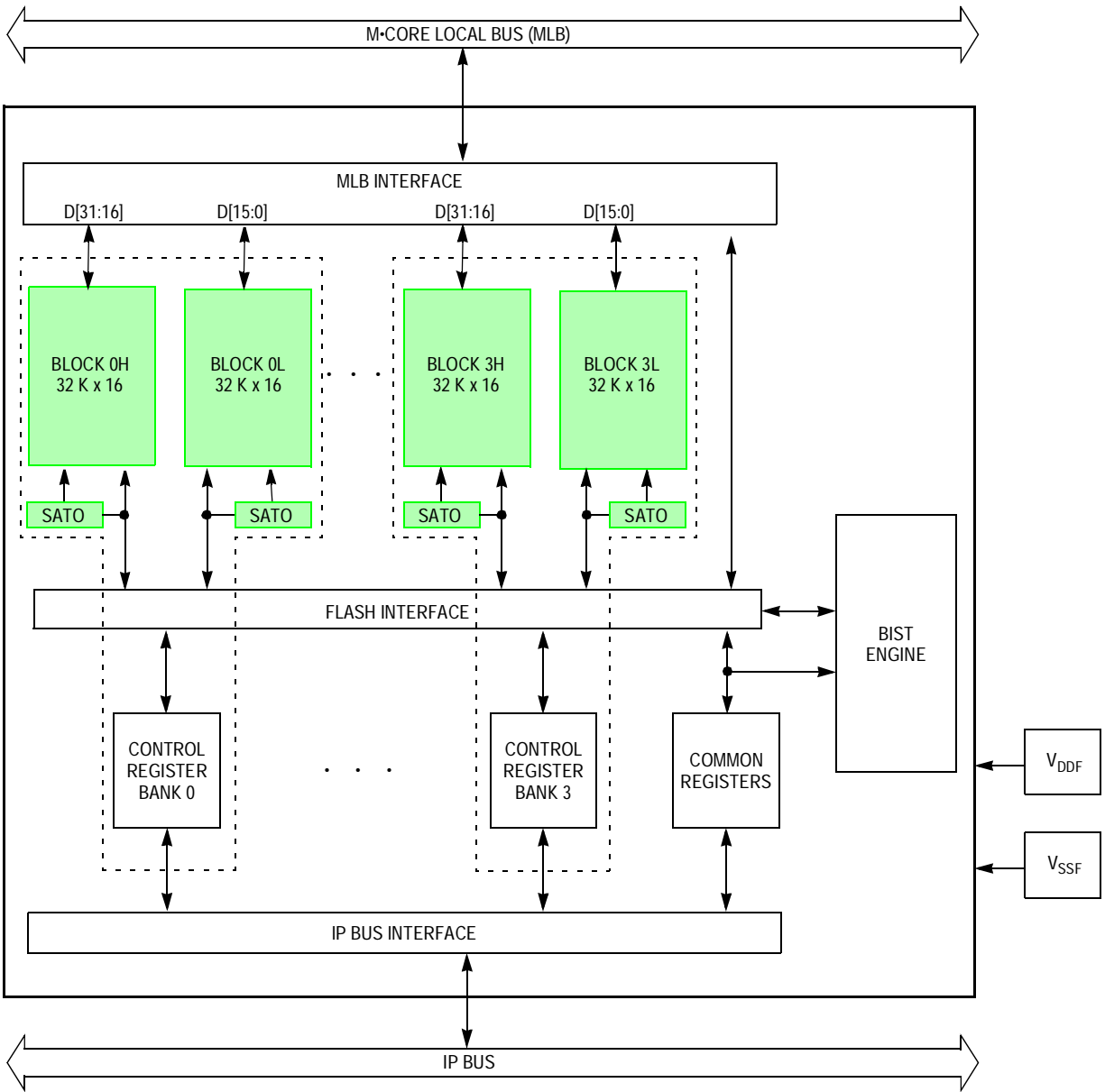
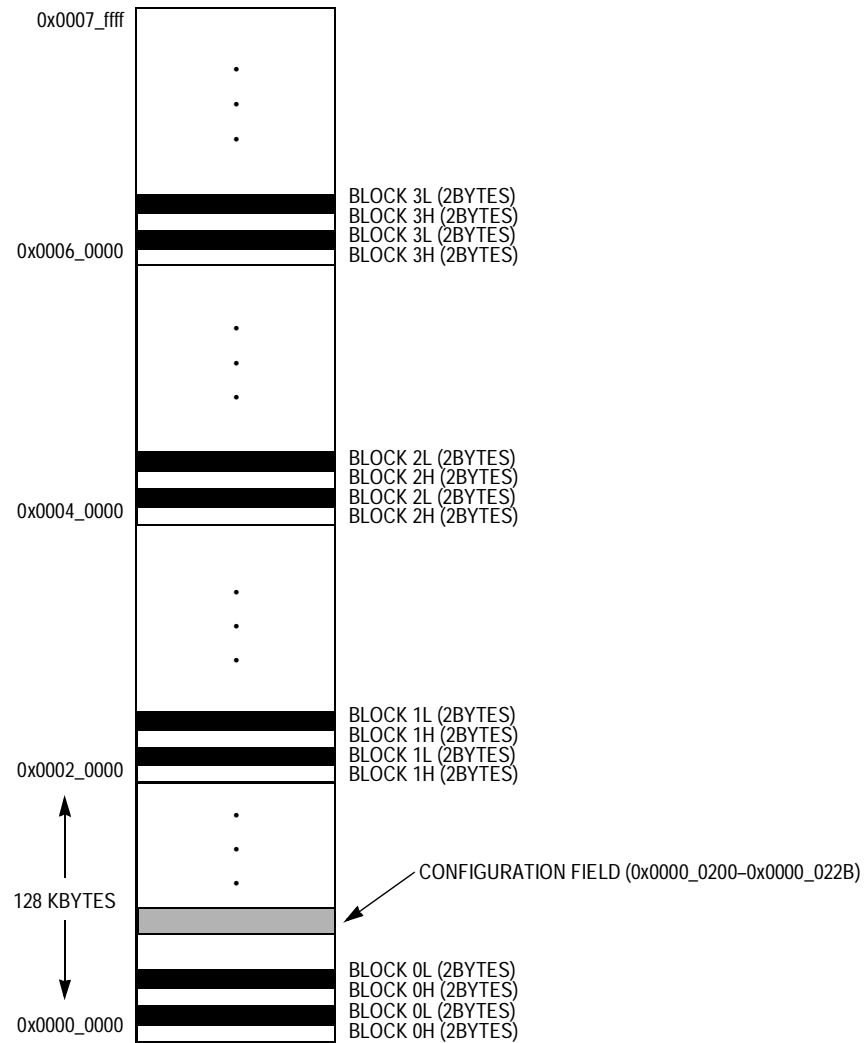

Figure 10-1. SGFM Module Block Diagram



## 10.7 Module Memory Map

The SGFM memory array is mapped starting at address 0x0000\_0000. **Figure 10-2** shows how multiple 32,768 by 16-bit FLASH physical blocks interleave to form a contiguous non-volatile memory space. Each pair of blocks (upper and lower) interleave every 2 bytes to form 128 Kbytes of memory.



**Figure 10-2. SGFM Array Memory Map**

The SGFM module has hardware interlocks to protect data from accidental corruption. The SGFM memory array is logically divided into 8-Kbyte sectors for the purpose of data protection and access control. A flexible scheme allows the protection of any combination of logical sectors (see [10.7.2.1 SGFM Protection Register](#)). A similar mechanism is available to control supervisor/user and program/data space access to these sectors.

The SGFM configuration field comprises 44 bytes of reserved array memory space that determines the module protection and access restrictions out of reset. Data to secure the FLASH from unauthorized access is also stored in the SGFM configuration field. [Table 10-1](#) describes each byte used in this field.

The SGFM module also contains a set of control and status registers. The memory map for these registers and their accessibility in supervisor and user modes is shown in [Table 10-2](#).

The SGFM module contains one to four sets of banked registers depending on the size of the array. The active register bank is selected via the BKSEL field in the unbanked Module Configuration Register (SGFMCR). Each set of banked registers controls the operation of two interleaving FLASH physical blocks such that Block 0L and Block 0H are controlled with one register bank. Other blocks are controlled in a similar fashion as shown in [Figure 10-2](#).

**Table 10-1. SGFM Configuration Field**

Address	Size in Bytes	Description
0x0000_0200–0x0000_0207	8	Back door comparison key
0x0000_0208–0x0000_0209	2	FLASH program/erase sector protection Blocks 0H/0L (see <a href="#">10.7.2.1 SGFM Protection Register</a> )
0x0000_020a–0x0000_020b	2	Reserved
0x0000_020c–0x0000_020d	2	FLASH supervisor/user space restrictions Blocks 0H/0L (see <a href="#">10.7.2.2 SGFM Supervisor Access Register</a> )
0x0000_020e–0x0000_020f	2	FLASH program/data space restrictions Blocks 0H/0L (see <a href="#">10.7.2.3 SGFM Data Access Register</a> )
0x0000_0210–0x0000_0211	2	FLASH program/erase sector protection <sup>(1)</sup> Blocks 1H/1L (see <a href="#">10.7.2.1 SGFM Protection Register</a> )
0x0000_0212–0x0000_0213	2	Reserved
0x0000_0214–0x0000_0215	2	FLASH supervisor/user space restrictions <sup>(1)</sup> Blocks 1H/1L (see <a href="#">10.7.2.2 SGFM Supervisor Access Register</a> )
0x0000_0216–0x0000_0217	2	FLASH program/data space restrictions <sup>(1)</sup> Blocks 1H/1L (see <a href="#">10.7.2.3 SGFM Data Access Register</a> )
0x0000_0218–0x0000_0219	2	FLASH program/erase sector protection <sup>(2)</sup> Blocks 2H/2L (see <a href="#">10.7.2.1 SGFM Protection Register</a> )
0x0000_021a–0x0000_021b	2	Reserved
0x0000_021c–0x0000_021d	2	FLASH supervisor/user space restrictions <sup>(2)</sup> Blocks 2H/2L (see <a href="#">10.7.2.2 SGFM Supervisor Access Register</a> )
0x0000_021e–0x0000_021f	2	FLASH program/data space restrictions <sup>(2)</sup> Blocks 2H/2L (see <a href="#">10.7.2.3 SGFM Data Access Register</a> )
0x0000_021e–0x0000_0221	2	FLASH program/erase sector protection <sup>(3)</sup> Blocks 3H/3L (see <a href="#">10.7.2.1 SGFM Protection Register</a> )
0x0000_0222–0x0000_0223	2	Reserved
0x0000_0224–0x0000_0225	2	FLASH supervisor/user space restrictions <sup>(3)</sup> Blocks 3H/3L (see <a href="#">10.7.2.2 SGFM Supervisor Access Register</a> )
0x0000_0226–0x0000_0227	2	FLASH program/data space restrictions <sup>(3)</sup> Blocks 3H/3L (see <a href="#">10.7.2.3 SGFM Data Access Register</a> )
0x0000_0228–0x0000_022b	4	FLASH security word (see <a href="#">10.7.1.4 SGFM Security Register</a> )

1. These configuration bytes are only required for 256-Kbyte arrays and larger.

2. These configuration bytes are only required for 384-Kbyte arrays and larger.

3. These configuration bytes are only required for 512-Kbyte arrays.

**Second Generation FLASH for M•CORE (SGFM)**
**Table 10-2. SGFM Register Address Map**

Address	Bits 31–24	Bits 23–16	Bits 15–8	Bits 7–0	Access <sup>(1)</sup>	Banked Register
0x00d0_0000	SGFMCR		SGFMCLKD	Reserved <sup>(2)</sup>	S	No
0x00d0_0004	SGFMTST	Reserved <sup>(2)</sup>			S	No
0x00d0_0008	SGFMSEC				S	No
0x00d0_000c	SGFMMNTR				S	No
0x00d0_0010	SGFMPROT		Reserved <sup>(2)</sup>		S	Yes
0x00d0_0014	SGFMSACC		SGFMDACC		S	Yes
0x00d0_0018	SGFMTSTAT	Reserved <sup>(2)</sup>			S	Yes
0x00d0_001c	SGFMUSTAT	Reserved <sup>(2)</sup>			S	Yes
0x00d0_0020	SGFMCMD	Reserved <sup>(2)</sup>			S	Yes
0x00d0_0024	SGFMCTL		SGFMADR		S	Yes
0x00d0_0028	SGFMDATA				S	Yes
0x00d0_002c– 0x00d0_003c	Unimplemented <sup>(3)</sup>				—	Yes

1. S = Supervisor access only. User mode accesses to supervisor only addresses have no effect and result in a cycle termination transfer error.
2. Writes to reserved address locations have no effect and reads return 0s.
3. Accesses to unimplemented addresses have no effect and result in a cycle termination transfer error.

### 10.7.1 Unbanked Register Descriptions

The unbanked registers are described in this subsection.

#### 10.7.1.1 SGFM Configuration Register

The SGFM Configuration Register (SGFMCR) is unbanked and is used to configure and control the operation of the SGFM array and bus interface unit (BIU).

Address: 0x00d0\_0000 and 0x00d0\_0001

	Bit 15	14	13	12	11	10	9	Bit 8
Read:	0	FRZ	0	EME	0	LOCK	0	0
Write:								
Reset:	0	0	0	Note 1	0	0	0	0
	Bit 7	6	5	4	3	2	1	Bit 0
Read:	CBEIE	CCIE	KEYACC	0	0	0	BKSEL1	BKSEL0
Write:								
Reset:	0	0	0	0	0	0	0	0

= Reserved

Note 1. Reset state determined by chip reset configuration.

**Figure 10-3. SGFM Module Configuration Register (SGFMCR)**

#### FRZ — Freeze Enable Bit

The FRZ bit is readable and writable in all modes. In debug mode the SGFM behaves exactly as it does in user mode except that the LOCK bit in SGFMCR and SGFMCLKD[6:0] bits are writable.

- 1 = Enter debug mode if debug signal on MLB is asserted
- 0 = Ignore debug mode if debug signal on MLB is asserted

#### EME — Emulation Enable Bit

The EME bit is always readable and only writable when LOCK = 0. EME places the SGFM in emulation mode, during which the SGFM BIU will not assert  $\overline{TA}$  or  $\overline{TEA}$  to terminate read bus cycles of the

SGFM array. Instead, external memory that emulates the FLASH must drive the data bus, and the EBI emulation chip select mechanism terminates the bus cycle instead of the SGFM.

**NOTE:** *In emulation mode, writes to the SGFM array will generate an SGFM access error and set the ACCERR bit (see [10.8.3.4 FLASH User Mode Illegal Operations](#)).*

- 1 = Emulation mode
- 0 = User mode

#### LOCK — Write Lock Control Bit

The LOCK bit is always readable but can only be set once in user mode. In debug or test mode, the LOCK bit is always writable.

- 1 = The EME bit, SGFMPROT, SGFMSACC, and SGFMDACC registers are write-locked
- 0 = The EME bit, SGFMPROT, SGFMSACC, and SGFMDACC registers are writable

#### CBEIE — Command Buffer Empty Interrupt Enable Bit

The CBEIE bit is readable and writable in all modes. CBEIE enables an interrupt request when the command buffer for the FLASH physical blocks selected by BKSEL[1:0] is empty.

- 1 = Request an interrupt whenever the CBEIF flag is set.
- 0 = Command buffer empty interrupts disabled

#### CCIE — Command Complete Interrupt Enable Bit

The CCIE bit is readable and writable in all modes. CCIE enables an interrupt when the command executing for the FLASH physical blocks selected by BKSEL[1:0] is complete.

- 1 = Request an interrupt whenever the CCIF flag is set.
- 0 = Command complete interrupts disabled

#### KEYACC — Enable Security Key Writing Bit

The KEYACC bit is readable in all modes and only writable if the KEYEN bit in the SGFMSEC register is set.

- 1 = Writes to the FLASH array are interpreted as keys to open the back door.
- 0 = Writes to the FLASH array are interpreted as the start of a program, erase, or verify sequence.

**BKSEL[1:0] — Register Bank Select Field**

The BKSEL bits are readable and writable in all modes and select which set of bank registers is accessible.

**Table 10-3** shows which set of banked registers is selected by the BKSEL field depending on the size of the FLASH memory array.

**Table 10-3. Register Bank Select Decoding**

BKSEL[1:0]	128 Kbytes	256 Kbytes	384 Kbytes	512 Kbytes
00	Bank 0	Bank 0	Bank 0	Bank 0
01	Bank 0	Bank 1	Bank 1	Bank 1
10	Bank 0	Bank 0	Bank 2	Bank 2
11	Bank 0	Bank 1	Bank 2	Bank 3

**10.7.1.2 SGFM Clock Divider Register**

The SGFM Clock Divider Register (SGFMCLKD) is unbanked and is used to set the frequency of the clock used for timed events in program and erase algorithms.

Address: 0x00d0\_0002

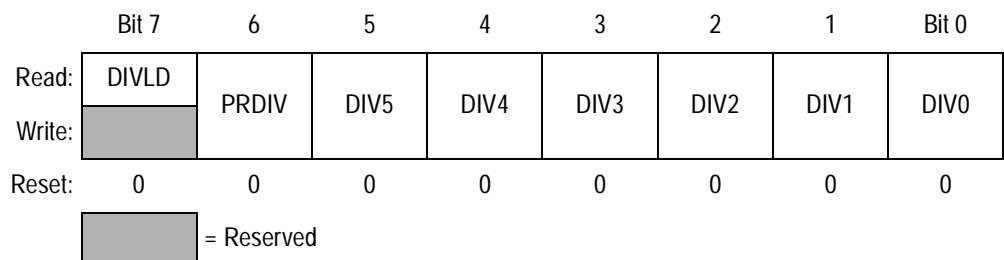

**Figure 10-4. SGFM Clock Divider Register (SGFMCLKD)**

In user mode, all bits in SGFMCLKD are readable while bits 6–0 can only be written once. In test and debug modes, all bits in SGFMCLKD are readable and writable at anytime, except bit 7 which is a status-only bit and is not writable in any mode.

Second Generation FLASH for M•CORE (SGFM)

- DIVLD — Clock Divider Loaded Bit
  - 1 = SGFMCLKD has been written since the last reset.
  - 0 = SGFMCLKD has not been written.
  
- PRDIV8 — Enable Prescaler Divide by 8 Bit
  - 1 = Enables a prescaler that divides the SGFM clock by 8 before it enters the SGFMCLKD divider.
  - 0 = The SGFM clock is fed directly into the SGFMCLKD divider.

DIV[5:0] — Clock Divider Field

The combination of PRDIV8 and DIV[5:0] effectively divides the SGFM input clock down to a frequency between 150 kHz and 200 kHz. The frequency range of the SGFM clock is 150 kHz to 102.4 MHz.

**NOTE:** *SGFMCLKD must be written with an appropriate value before programming or erasing the FLASH array. Refer to [10.8.3.1 Setting the SGFMCLKD Register](#).*

10.7.1.3 SGFM Test Register

The SGFM Test Register (SGFMTST) is unbanked and is used only for factory testing.

Address: 0x00d0\_0004

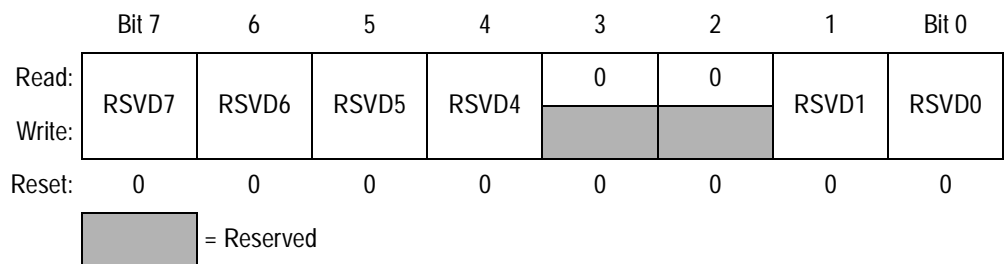

**Figure 10-5. SGFM Test Register (SGFMTST)**

Accesses to SGFMTST when not in test mode will result in a cycle termination transfer error.



10.7.1.4 SGFM Security Register

The SGFM Security Register (SGFMSEC) is unbanked and controls the FLASH security features.

Address: 0x00d0\_0008 through 0x00d0\_000b

	Bit 31	30	29	28	27	26	25	Bit 24
Read:	KEYEN	SECSTAT	0	0	0	0	0	0
Write:								
Reset:	F <sup>(1)</sup>	Note 2	0	0	0	0	0	0
	Bit 23	22	21	20	19	18	17	Bit 16
Read:	0	0	0	0	0	0	0	0
Write:								
Reset:	0	0	0	0	0	0	0	0
	Bit 15	14	13	12	11	10	9	Bit 8
Read:	SEC15	SEC14	SEC13	SEC12	SEC11	SEC10	SEC9	SEC8
Write:								
Reset:	F <sup>(1)</sup>	F <sup>(1)</sup>	F <sup>(1)</sup>	F <sup>(1)</sup>	F <sup>(1)</sup>	F <sup>(1)</sup>	F <sup>(1)</sup>	F <sup>(1)</sup>
	Bit 7	6	5	4	3	2	1	Bit 0
Read:	SEC7	SEC6	SEC5	SEC4	SEC3	SEC2	SEC1	SEC0
Write:								
Reset:	F <sup>(1)</sup>	F <sup>(1)</sup>	F <sup>(1)</sup>	F <sup>(1)</sup>	F <sup>(1)</sup>	F <sup>(1)</sup>	F <sup>(1)</sup>	F <sup>(1)</sup>

= Reserved

Notes:

1. Reset state loaded from FLASH configuration field during reset.
2. Reset state determined by security state of module.

**Figure 10-6. SGFM Security Register (SGFMSEC)**

SGFMSEC is readable in all modes but is not writable in any mode.

SGFMSEC register bits with a reset state denoted by F in [Figure 10-6](#) are loaded from the FLASH configuration at address 0x0000\_0228 during the reset sequence.

KEYEN — Enable Back Door Key to Security Bit

- 1 = Back door to FLASH is enabled.
- 0 = Back door to FLASH is disabled.

SECSTAT — FLASH Security Status Bit

- 1 = FLASH security is enabled
- 0 = FLASH security is disabled

SEC[15:0] — Security Field

The SEC bits define the security state of the device. [Table 10-4](#) lists the single code that enables security.

**Table 10-4. Security States**

SEC[15:0]	Description
\$000B	FLASH secured <sup>(1)</sup>
All other combinations	FLASH unsecured

1. The \$000B value was chosen because it represents the M•CORE TRAP #3 opcode, making it unlikely that compiled code accidentally programmed at the security word in the FLASH configuration field location would unintentionally secure the device.

The security features of the SGFM are described in [10.9 FLASH Security Operation](#).

10.7.1.5 SGFM Monitor Data Register

The SGFM Monitor Data Register (SGFMMNTR) is unbanked and is used only for factory testing.

Address: 0x00d0\_000c through 0x00d0\_000f

	Bit 31	30	29	28	27	26	25	Bit 24
Read:	RSVD31	RSVD30	RSVD29	RSVD28	RSVD27	RSVD26	RSVD25	RSVD24
Write:								
Reset:	Note 1							
	Bit 23	22	21	20	19	18	17	Bit 16
Read:	RSVD23	RSVD22	RSVD21	RSVD20	RSVD19	RSVD18	RSVD17	RSVD16
Write:								
Reset:	Note 1							
	Bit 15	14	13	12	11	10	9	Bit 8
Read:	RSVD15	RSVD14	RSVD13	RSVD12	RSVD11	RSVD10	RSVD9	RSVD8
Write:								
Reset:	Note 1							
	Bit 7	6	5	4	3	2	1	Bit 0
Read:	RSVD7	RSVD6	RSVD5	RSVD4	RSVD3	RSVD2	RSVD1	RSVD0
Write:								
Reset:	Note 1							

= Reserved

Note 1. SGFMMNTR does not have a default reset state.

**Figure 10-7. SGFM Monitor Data Register (SGFMMNTR)**

Accesses to SGFMMNTR when not in test mode will result in a cycle termination transfer error.

### 10.7.2 Banked Register Descriptions

The banked registers are described in this subsection.

#### 10.7.2.1 SGFM Protection Register

The SGFM Protection Register (SGFMPROT) is banked and specifies which FLASH logical sectors are protected from program and erase operations.

Address: 0x00d0\_0010 and 0x00d0\_0011

	Bit 15	14	13	12	11	10	9	Bit 8
Read:	PROT15	PROT14	PROT13	PROT12	PROT11	PROT10	PROT9	PROT8
Write:								
Reset:	F <sup>(1)</sup>	F <sup>(1)</sup>	F <sup>(1)</sup>	F <sup>(1)</sup>	F <sup>(1)</sup>	F <sup>(1)</sup>	F <sup>(1)</sup>	F <sup>(1)</sup>
	Bit 7	6	5	4	3	2	1	Bit 0
Read:	PROT7	PROT6	PROT5	PROT4	PROT3	PROT2	PROT1	PROT0
Write:								
Reset:	F <sup>(1)</sup>	F <sup>(1)</sup>	F <sup>(1)</sup>	F <sup>(1)</sup>	F <sup>(1)</sup>	F <sup>(1)</sup>	F <sup>(1)</sup>	F <sup>(1)</sup>

Note 1. Reset state loaded from FLASH configuration field during reset.

**Figure 10-8. SGFM Protection Register (SGFMPROT)**

The SGFMPROT register is always readable and only writable when LOCK = 0. To change which logical sectors are protected on a temporary basis, write SGFMPROT with a new value after the LOCK bit in SGFMCR has been cleared. To change the value of SGFMPROT that will be loaded on reset, the protection byte in the FLASH configuration field must be reprogrammed for the interleaved FLASH physical blocks currently selected by BKSEL[1:0]. If necessary, the logical sector containing the FLASH configuration field must be temporarily unprotected using the method just described before reprogramming the protection bytes.

#### PROT[15:0] — Sector Protection Bits

Each FLASH logical sector can be protected from program and erase operations by setting its corresponding PROT bit.

1 = Logical sector is protected.

0 = Logical sector is not protected.

Each banked SGFMPROT register controls the protection of sixteen 8-Kbyte FLASH logical sectors in a 128-Kbyte bank of memory (two interleaved FLASH physical blocks). **Figure 10-9** shows the association between each bit in the SGFMPROT register and its corresponding logical sector.

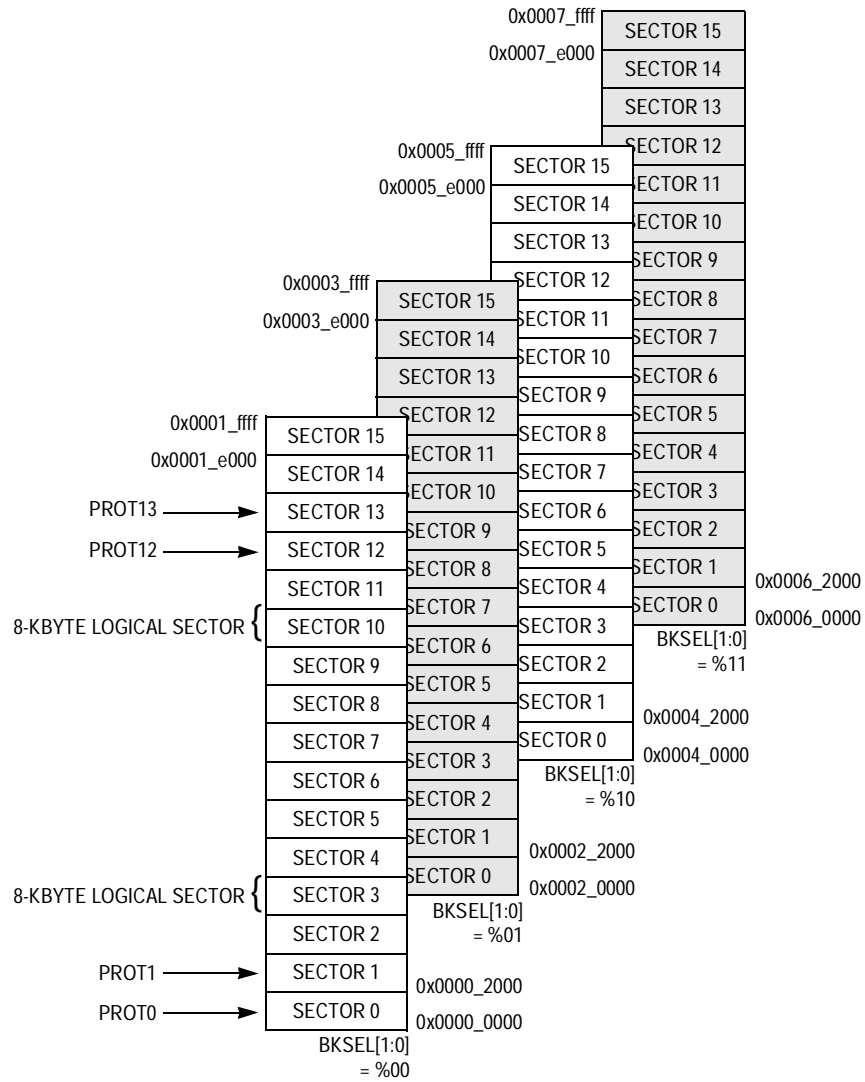

**Figure 10-9. SGFMPROT Protection Diagram**

10.7.2.2 SGFM Supervisor Access Register

The SGFM Supervisor Access Register (SGFMSACC) is banked and specifies the supervisor/user access permissions of FLASH logical sectors.

Address: 0x00d0\_0014 and 0x00d0\_0015

	Bit 15	14	13	12	11	10	9	Bit 8
Read:	SUPV15	SUPV14	SUPV13	SUPV12	SUPV11	SUPV10	SUPV9	SUPV8
Write:								
Reset:	F <sup>(1)</sup>	F <sup>(1)</sup>	F <sup>(1)</sup>	F <sup>(1)</sup>	F <sup>(1)</sup>	F <sup>(1)</sup>	F <sup>(1)</sup>	F <sup>(1)</sup>
	Bit 7	6	5	4	3	2	1	Bit 0
Read:	SUPV7	SUPV6	SUPV5	SUPV4	SUPV3	SUPV2	SUPV1	SUPV0
Write:								
Reset:	F <sup>(1)</sup>	F <sup>(1)</sup>	F <sup>(1)</sup>	F <sup>(1)</sup>	F <sup>(1)</sup>	F <sup>(1)</sup>	F <sup>(1)</sup>	F <sup>(1)</sup>

Note 1. Reset state loaded from FLASH configuration field during reset.

**Figure 10-10. SGFM Supervisor Access Register (SGFMSACC)**

SUPV[15:0] — Supervisor Address Space Assignment Bits

The SUPV[15:0] bits are always readable and only writable when LOCK = 0. Each FLASH logical sector can be mapped into supervisor or unrestricted address space. SGFMSACC uses the same correspondence between logical sectors and register bits as does SGFMPROT. See [Figure 10-9](#) for details.

When a logical sector is mapped into supervisor address space, only CPU supervisor accesses will be allowed. A CPU user access to a location in supervisor address space will result in a cycle termination transfer error. When a logical sector is mapped into unrestricted address space both supervisor and user accesses are allowed.

- 1 = Logical sector is mapped in supervisor address space.
- 0 = Logical sector is mapped in unrestricted address space.

10.7.2.3 SGFM Data Access Register

The SGFM Data Access Register (SGFMDACC) is banked and specifies the data/program access permissions of FLASH logical sectors.

Address: 0x00d0\_0016 and 0x00d0\_0017

	Bit 15	14	13	12	11	10	9	Bit 8
Read:	DATA15	DATA14	DATA13	DATA12	DATA11	DATA10	DATA9	DATA8
Write:								
Reset:	F <sup>(1)</sup>	F <sup>(1)</sup>	F <sup>(1)</sup>	F <sup>(1)</sup>	F <sup>(1)</sup>	F <sup>(1)</sup>	F <sup>(1)</sup>	F <sup>(1)</sup>
	Bit 7	6	5	4	3	2	1	Bit 0
Read:	DATA7	DATA6	DATA5	DATA4	DATA3	DATA2	DATA1	DATA0
Write:								
Reset:	F <sup>(1)</sup>	F <sup>(1)</sup>	F <sup>(1)</sup>	F <sup>(1)</sup>	F <sup>(1)</sup>	F <sup>(1)</sup>	F <sup>(1)</sup>	F <sup>(1)</sup>

Note 1. Reset state loaded from FLASH configuration field during reset.

**Figure 10-11. SGFM Data Access Register (SGFMDACC)**

DATA[15:0] — Data Address Space Assignment Bits

The DATA[15:0] bits are always readable and only writable when LOCK = 0. Each FLASH logical sector can be mapped into data or both data and program address space. SGFMDACC uses the same correspondence between logical sectors and register bits as does SGFMProt. See [Figure 10-9](#) for details.

When a logical sector is mapped into data address space, only CPU data accesses will be allowed. A CPU program access to a location in data address space will result in a cycle termination transfer error. When an array sector is mapped into both data and program address space both data and program accesses are allowed.

- 1 = Logical sector is mapped in data address space.
- 0 = Logical sector is mapped in data and program address space.

Second Generation FLASH for M•CORE (SGFM)

10.7.2.4 SGFM Test Status Register

The SGFM Test Status Register (SGFMTSTAT) is banked and is used only for factory testing.

Address: 0x00d0\_0018

	Bit 7	6	5	4	3	2	1	Bit 0
Read:	0	0	0	0	RSVD3	0	RSVD1	RSVD0
Write:								
Reset:	0	0	0	0	0	0	0	0

= Reserved

Figure 10-12. SGFM Test Status Register (SGFMTSTAT)

Accesses to SGFMSTAT when not in test mode will result in a cycle termination transfer error.

10.7.2.5 SGFM User Status Register

The SGFM User Status Register (SGFMUSTAT) is banked reports FLASH state machine command status, array access errors, protection violations, and blank check status.

Address: 0x00d0\_001c

	Bit 7	6	5	4	3	2	1	Bit 0
Read:		CCIF			0		0	0
Write:	CBEIF		PVIOL	ACCERR		BLANK		
Reset:	1	1	0	0	0	0	0	0

= Reserved

Figure 10-13. SGFM User Status Register (SGFMUSTAT)

SGFMUSTAT bits 7, 5, 4, and 2 are readable and writable in all modes. Bits 3, 1, and 0 always read 0 and writes have no effect. Bit 6 is a read-only bit in all modes.

**NOTE:** Only one SGFMUSTAT bit should be cleared at a time.



**CBEIF — Command Buffer Empty Interrupt Flag**

The CBEIF flag indicates that the command buffer for the interleaved FLASH physical blocks selected by BKSEL[1:0] is empty and that a new command sequence can be started. Clear CBEIF by writing it to 1. Writing a 0 to CBEIF has no effect but can be used to abort a command sequence. The CBEIF bit can trigger an interrupt request if the CBEIE bit is set in SGFMMCR. While CBEIF is clear, the SGFMCMD register is not writable.

- 1 = Command buffer is ready to accept a new command.
- 0 = Command buffer is full.

**CCIF — Command Complete Interrupt Flag**

The CCIF flag indicates that no commands are pending for the FLASH physical blocks selected by BKSEL[1:0]. CCIF is set and cleared automatically upon start and completion of a command. Writing to CCIF has no effect. The CCIF bit can trigger an interrupt request if the CCIE bit is set in SGFMCR.

- 1 = All commands are completed
- 0 = Command in progress

**PVIOL — Protection Violation Flag**

The PVIOL flag indicates an attempt was made to initiate a program or erase operation in a FLASH logical sector denoted as protected by SGFMProt. Clear PVIOL by writing it to 1. Writing a 0 to PVIOL has no effect. While PVIOL is set in any banked register, it is not possible to launch another command.

- 1 = A protection violation has occurred
- 0 = No failure

**ACCERR — Access Error Flag**

The ACCERR flag indicates an illegal access to the SGFM array or registers caused by a bad program or erase sequence. ACCERR is cleared by writing it to 1. Writing a 0 to ACCERR has no effect. While ACCERR is set in any banked register, it is not possible to launch another command. See [10.8.3.4 FLASH User Mode Illegal Operations](#) for details on what sets the ACCERR flag.

- 1 = Access error has occurred
- 0 = No failure

**BLANK — Erase Verified Flag**

The BLANK flag indicates that the erase verify command (RDARY1) has checked the two interleaved FLASH physical blocks selected by BKSL[1:0] and found them to be blank. Clear BLANK by writing it to 1. Writing a 0 has no effect.

1 = FLASH physical blocks verify as erased.

0 = If an erase verify command has been requested, and the CCIF flag is set, then the selected FLASH physical blocks are not blank.

**10.7.2.6 SGFM Command Register**

The SGFM Command Register (SGFMCMD) is banked and is the register to which FLASH program, erase, and verify commands are written.

Address: 0x00d0\_0020

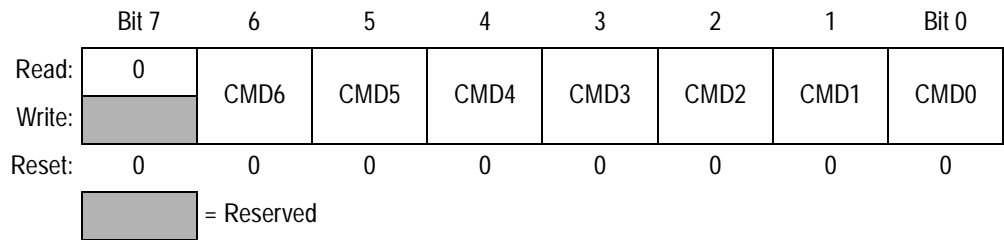

**Figure 10-14. SGFM Command Register (SGFMCMD)**

SGFMCMD is readable and writable in all modes. Writes to bit 7 have no effect and reads return 0.

**CMD[6:0] — Command Field**

Valid FLASH user mode commands are shown in [Table 10-5](#). Writing a command in user mode other than those listed in [Table 10-5](#) will set the ACCERR flag in SGFMUSTAT.

**Table 10-5. SGFMCMD User Mode Commands**

Command	Name	Description
\$05	RDARY1	Erase verify (all 1s)
\$20	PGM	Word program
\$40	PGERS	Page erase
\$41	MASERS	Mass erase

10.7.2.7 SGFM Control Register

The SGFM Control Register (SGFMCTL) is banked and is used only for factory testing.

Address: 0x00d0\_0024 and 0x00d0\_0025

	Bit 15	14	13	12	11	10	9	Bit 8
Read:	RSVD15	0	0	0	0	0	0	0
Write:								
Reset:	0	0	0	0	0	0	0	0
	Bit 7	6	5	4	3	2	1	Bit 0
Read:	RSVD7	RSVD6	RSVD5	RSVD4	RSVD3	RSVD2	RSVD1	RSVD0
Write:								
Reset:	0	0	0	0	0	0	0	0

 = Reserved

**Figure 10-15. SGFM Control Register (SGFMCTL)**

Accesses to SGFMCTL when not in test mode will result in a cycle termination transfer error.

**Second Generation FLASH for M•CORE (SGFM)**

10.7.2.8 SGFM Address Register

The SGFM Address Register (SGFMADR) is a banked register and is used only for factory testing.

Address: 0x00d0\_0026 and 0x00d0\_0027

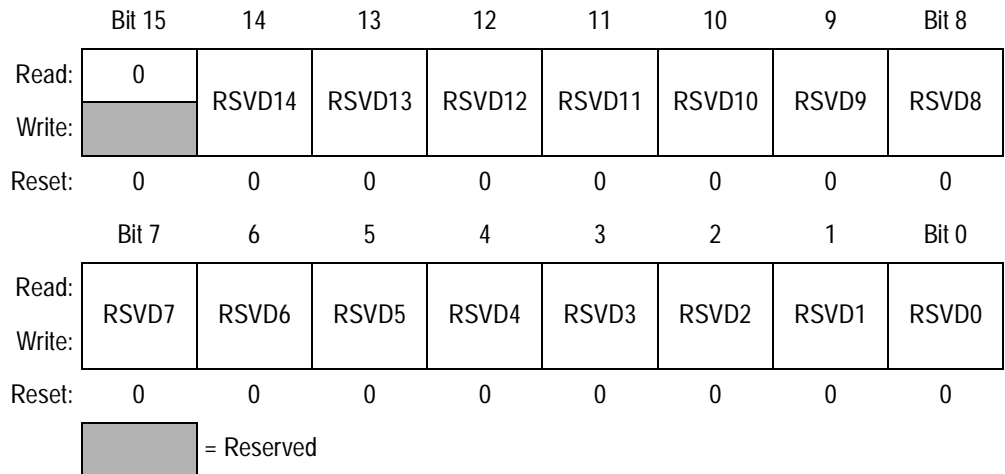

**Figure 10-16. SGFM Address Register (SGFMADR)**

Access to SGFMADR when not in test mode will result in a cycle termination transfer error.

10.7.2.9 SGFM Data Register

The SGFM Data Register (SGFMDATA) is a banked register and is used only for factory testing.

Address: 0x00d0\_0028 through 0x00d0\_002b

	Bit 31	30	29	28	27	26	25	Bit 24
Read:	RSVD31	RSVD30	RSVD29	RSVD28	RSVD27	RSVD26	RSVD25	RSVD24
Write:	RSVD31	RSVD30	RSVD29	RSVD28	RSVD27	RSVD26	RSVD25	RSVD24
Reset:	0	0	0	0	0	0	0	0
	Bit 23	22	21	20	19	18	17	Bit 16
Read:	RSVD23	RSVD22	RSVD21	RSVD20	RSVD19	RSVD18	RSVD17	RSVD16
Write:	RSVD23	RSVD22	RSVD21	RSVD20	RSVD19	RSVD18	RSVD17	RSVD16
Reset:	0	0	0	0	0	0	0	0
	Bit 15	14	13	12	11	10	9	Bit 8
Read:	RSVD15	RSVD14	RSVD13	RSVD12	RSVD11	RSVD10	RSVD9	RSVD8
Write:	RSVD15	RSVD14	RSVD13	RSVD12	RSVD11	RSVD10	RSVD9	RSVD8
Reset:	0	0	0	0	0	0	0	0
	Bit 7	6	5	4	3	2	1	Bit 0
Read:	RSVD7	RSVD6	RSVD5	RSVD4	RSVD3	RSVD2	RSVD1	RSVD0
Write:	RSVD7	RSVD6	RSVD5	RSVD4	RSVD3	RSVD2	RSVD1	RSVD0
Reset:	0	0	0	0	0	0	0	0

**Figure 10-17. SGFM Data Register (SGFMDATA)**

Accesses to SGFMDATA when not in test mode will result in a cycle termination transfer error.

## 10.8 SGFM User Mode

Normal operation of the SGFM occurs in user mode. The SGFM registers, subject to the restrictions previously noted, can generally be read and written. Reads of the SGFM array generally occur normally and writes behave according to the setting of the KEYACC bit in SGFMCR. Program, erase, and verify operations are initiated by the CPU. Special cases of user mode apply when the CPU is in low power or debug modes and when the MCU boots in master mode or emulation mode.

### 10.8.1 Read Operations

A valid read operation occurs whenever a transfer request is initiated by the M•CORE, the MLB address is equal to an address within the valid range of the SGFM memory space, and the read/write control indicates a read cycle. Aligned read accesses (byte, halfword, or word) complete in one system clock cycle. Misaligned accesses are not allowed and result in a cycle termination transfer error.

In order to reduce power at low system clock frequencies, the sense amplifier timeout (SATO) block minimizes the time during which the sense amplifiers are enabled for read operations. The sense amplifier enable signals to the FLASH timeout after approximately 50 ns.

### 10.8.2 Write Operations

A valid write operation occurs whenever a transfer request is initiated by the M•CORE, the MLB address is equal to an address within the valid range of the SGFM memory space, and the read/write control indicates a write cycle.

The action taken on a valid SGFM array write depends on the subsequent user command issued as part of a valid command sequence. Only aligned 32-bit write operations are allowed to the SGFM array. Byte and halfword write operations will result in a cycle termination transfer error.

### 10.8.3 Program and Erase Operations

Read and write operations are both used for the program and erase algorithms described in this subsection. These algorithms are controlled by a state machine whose timebase is derived from the SGFM module clock via a programmable counter.

The command register and associated address and data buffers operate as a two stage FIFO so that a new command along with the necessary address and data can be stored while the previous command is still in progress. This pipelining speeds when programming more than one word on a specific row, as the charge pumps can be kept on in between two programming commands, thus saving the overhead needed to setup the charge pumps. Buffer empty and command completion are indicated by flags in the SGFM User Status Register. Interrupts will be requested if enabled.

#### 10.8.3.1 Setting the SGFMCLKD Register

Prior to issuing any program or erase commands, SGFMCLKD must be written to set the FLASH state machine clock (FCLK). The SGFM module runs at the system clock frequency, but FCLK must be divided down from the system clock to a frequency between 150 kHz and 200 kHz. Use the following procedure to set the PRDIV8 and DIV[5:0] bits in SGFMCLKD:

1. If  $f_{SYS}$  is greater than 12.8 MHz,  $PRDIV8 = 1$ , otherwise  $PRDIV8 = 0$ .
2. Determine DIV[5:0] by using the following equation. Keep only the integer portion of the result and discard any fraction. Do not round the result.

$$DIV[5:0] = \frac{f_{SYS}}{1 + (PRDIV8 \times 7)} \div 200 \text{ kHz}$$

3. Thus the FLASH state machine clock will be:

$$FCLK = \frac{f_{SYS}}{DIV[5:0] + 1}$$

Consider the following example for  $f_{SYS} = 33$  MHz:

$$f_{SYS} = 12.8 \text{ MHz, so PRDIV8} = 1$$

$$DIV[5:0] = \frac{f_{SYS}}{1 + (PRDIV8 \times 7)} = \frac{33 \text{ MHz}}{1 + (1 \times 7)} = 20$$

$$FCLK = \frac{f_{SYS}}{DIV[5:0] + 1} = \frac{33 \text{ MHz}}{20 + 1} = 196.43 \text{ kHz}$$

So, for  $f_{SYS} = 33$  MHz, writing \$54 to SGFMCLKD will set FCLK to 196.43 kHz which is a valid frequency for the timing of program and erase operations.

**WARNING:** *For proper program and erase operations, it is critical to set FCLK between 150 kHz and 200 kHz. Array damage due to overstress can occur when FCLK is less than 150 kHz. Incomplete programming and erasure can occur when FCLK is greater than 200 kHz.*

**NOTE:** *Command execution time increases proportionally with the period of FCLK.*

When SGFMCLKD is written, the DIVLD bit is set automatically. If DIVLD is 0, SGFMCLKD has not been written since the last reset. Program and erase commands will not execute if this register has not been written (see [10.8.3.4 FLASH User Mode Illegal Operations](#)).

### 10.8.3.2 Program, Erase, and Verify Sequences

A command state machine is used to supervise the write sequencing of program, erase, and verify commands. Before any command write sequence is started, it is necessary to write the BKSEL field SGFMMCR to select the banked set of registers associated with the FLASH physical blocks to be programmed or erased (see [Figure 10-2](#) for more details). To prepare for a command, the CBEIF flag should be tested to ensure that the address, data, and command buffers are empty. If CBEIF is set, the command write sequence can be started.



This three-step command write sequence must be strictly followed. No intermediate writes to the SGFM module are permitted between these three steps. The command write sequence is:

1. Write the 32-bit word to be programmed to its location in the SGFM array. The address and data will be stored in internal buffers. All address bits are valid for program commands. The value of the data written for verify and erase commands is ignored. For mass erase or verify, the address can be any location in the SGFM array. For page erase, address bits [9:0] are ignored.

**NOTE:** *The page erase command operates simultaneously on adjacent erase pages in two interleaved FLASH physical blocks. Thus, a single erase page is effectively 1 Kbyte.*

2. Write the program, erase, or verify command to SGFMCMD, the command buffer. See [10.8.3.3 FLASH User Mode Valid Commands](#).
3. Launch the command by writing a 1 to the CBEIF flag. This will clear CBEIF. When command execution is complete, the FLASH state machine will set the CCIF flag. The CBEIF flag will also be set again, indicating that the address, data, and command buffers are ready for a new command sequence to begin.

**NOTE:** *On devices with 256 Kbytes of FLASH or more, concurrent command execution is possible. After a command is launched for the FLASH physical blocks serviced by the current set of banked registers, BKSEL[1:0] can be changed in order to launch a command for another pair of FLASH physical blocks. A command launched for one pair of FLASH physical blocks will not interfere with the execution of commands launched for other FLASH physical blocks and will only set the CCIF flag in the SGFMUSTAT register selected by BKSEL[1:0] at the time the command was launched.*

The FLASH state machine will flag errors in command write sequences by means of the ACCERR and PVIOL flags in the SGFMUSTAT register. An erroneous command write sequence will self-abort and set the appropriate flag. The ACCERR or PVIOL flags must be cleared before commencing another command write sequence.

Second Generation FLASH for M•CORE (SGFM)

**NOTE:** By writing a 0 to CBEIF, a command sequence can be aborted after the word write to the SGFM array or the command write to the SGFMCMD and before the command is launched. The ACCERR flag will be set on aborted commands and must be cleared before a new command write sequence.

A summary of the programming algorithm is shown in [Figure 10-18](#). The flow is similar for the erase and verify algorithms with the exceptions noted in step 1 above.

10.8.3.3 FLASH User Mode Valid Commands

[Table 10-6](#) summarizes the valid FLASH user commands.

**Table 10-6. FLASH User Mode Commands**

SGFMCMD	Meaning	Description
\$05	Erase verify	Verify that all 128 Kbytes of FLASH from two interleaving physical blocks are erased. If both blocks are erased, the BLANK bit will set in the SGFMUSTAT register upon command completion.
\$20	Program	Program a 32-bit word.
\$40	Page erase	Erase 1 Kbyte of FLASH. Two 512 byte pages from interleaving physical blocks are erased in this operation.
\$41	Mass erase	Erase all 128 Kbytes of FLASH from two interleaving physical blocks. A mass erase is only possible when no PROTECT bits are set for that block.

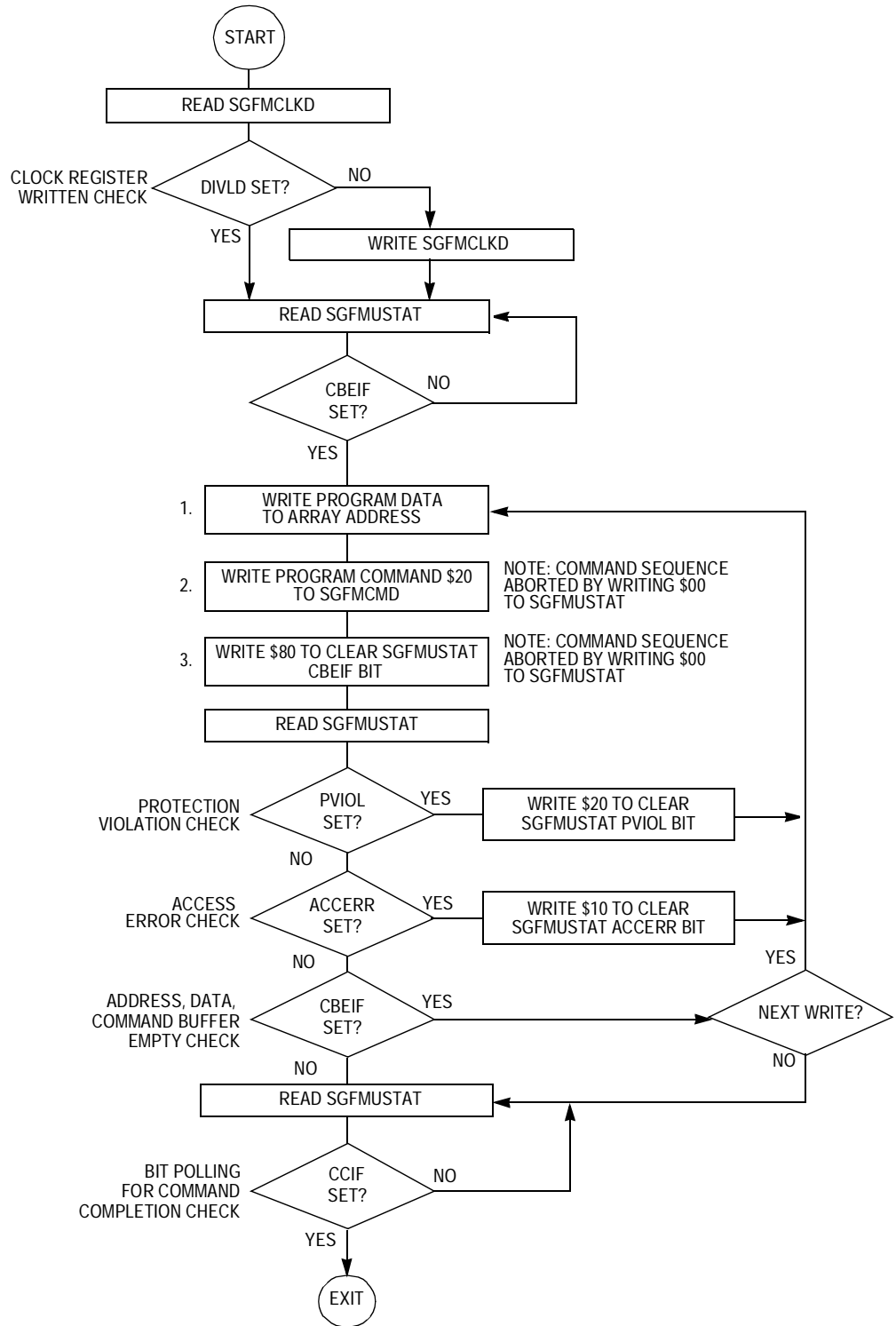

**Figure 10-18. Example Program Algorithm**

#### 10.8.3.4 FLASH User Mode Illegal Operations

The ACCERR flag will be set during a command write sequence if any of the illegal operations below are performed. Such operations will cause the command sequence to immediately abort.

1. Writing to the SGFM array before initializing SGFMCLKD.
2. Writing to the SGFM array while in emulation mode.
3. Writing a byte or a halfword to the SGFM array. Only 32-bit word programming is allowed.
4. Writing to the SGFM array at a location that does not match BKSEL[1:0]. Depending on the size of the FLASH array, MLB address bits [18:17] must match BKSEL[1:0].
5. Writing to the SGFM array while CBEIF is not set.
6. Writing a second word to the SGFM array before executing a command on the previously written word.
7. Writing an invalid user command to the SGFMCMD.
8. Writing to any SGFM other than SGFMCMD after writing a word to the SGFM array.
9. Writing a second command to SGFMCMD before executing the previously written command.
10. Writing to any SGFM register other than SGFMUSTAT (to clear CBEIF) after writing to the command register.
11. Entering stop mode while a program or erase command is in progress.
12. Aborting a command sequence by writing a 0 to CBEIF after the word write to the SGFM array or after writing a command to SGFMCMD and before launching it.

The PVIOL flag will be set during a command write sequence after the word write to the SGFM array if any of the illegal operations below are performed. Such operations will cause the command sequence to immediately abort.

1. Writing to an address in a protected area of the SGFM array.
2. Writing a mass erase command to SGFMCMD while any logical sector is protected (see [10.7.2.1 SGFM Protection Register](#)).

If a FLASH physical block is read during a program or erase operation on that block (SGFMUSTAT bit CCIF = 0), the read will return non-valid data and the ACCERR flag will not be set.

#### 10.8.4 Stop Mode

If a command is active (CCIF = 0) when the MCU enters stop mode, the command sequence monitor will perform the following:

1. The command in progress will be aborted.
2. The FLASH high voltage circuitry will be switched off and any pending command (CBEIF = 0) will not be executed when the MCU exits stop mode.
3. The CCIF and ACCERR flags will be set if a command is active when the MCU enters stop mode.

**NOTE:** *The state of any word(s) being programmed or any erase pages/physical blocks being erased is not guaranteed if the MCU enters stop mode with a command in progress.*

**WARNING:** *Active commands are immediately aborted when the MCU enters stop mode. Do not execute the STOP instruction during program and erase operations.*

**Second Generation FLASH for M•CORE (SGFM)****10.8.5 Master Mode**

If the MCU is booted in master mode with an external memory selected as the boot device, the SGFM will not respond to the first transfer request out of reset, even if the MLB address is equal to an address within the SGFM array. This will allow the external boot device to provide the reset vector and terminate the bus cycle.

**10.8.6 Emulation Mode**

In emulation mode, the SGFM module will not terminate the bus cycles by asserting  $\overline{TA}$  or  $\overline{TEA}$  in response to array read requests. External memory that emulates the FLASH will drive the data bus and the EBI emulation chip mechanism will terminate the bus cycle instead of the SGFM module.

**NOTE:** *In emulation mode, write accesses to the SGFM array will generate an SGFM access error and set the ACCERR bit.*

**10.8.7 Debug Mode**

In debug mode, the SGFM module behaves exactly as it does in user mode, except that the LOCK bit in SGFMMCR and the SGFMCLKD[6:0] register bits are always writable.

**10.9 FLASH Security Operation**

The SGFM array provides security information to the integration module and the rest of the MCU. A word in the FLASH configuration field stores this information. This word is read automatically after each reset and is stored in the SGFMSEC register.

In user mode, security can be bypassed via a back door access scheme using an 8-byte long key. Upon successful completion of the back door access sequence, the module output signal and status bit indicating that the chip is secure are cleared.

The SGFM may be unsecured via one of two methods:

1. Executing a back door access scheme.
2. Passing an erase verify check.

### 10.9.1 Back Door Access

If the KEYEN bit is set, security can be bypassed by:

1. Setting the KEYACC bit in the SGFM Configuration Register (SGFMMCR).
2. Writing the correct 8-byte back door comparison key to the SGFM array at addresses 0x0000\_0200 to 0x0000\_0207. This operation must consist of two 32-bit writes to address 0x0000\_0200 and 0x0000\_0204 in that order. The two back door write cycles can be separated by any number of bus cycles.
3. Clearing the KEYACC bit.
4. If all 8 bytes written match the array contents at addresses 0x0000\_0200 to 0x0000\_0207, then security is bypassed until the next reset.

**NOTE:** *The security of the FLASH as defined by the FLASH security word at address 0x0000\_0228 is not changed by the back door method of unsecuring the device. After the next reset the device is again secured and the same back door key remains in effect unless changed by program or erase operations. The back door method of unsecuring the device has no effect on the program and erase protections defined by the SGFM Protection Register (SGFMPROT).*

### 10.9.2 Erase Verify Check

Security can be disabled by verifying that the SGFM array is blank. If required, the mass erase command can be executed for each pair of FLASH physical blocks that comprise the array. The erase verify command must then be executed for all FLASH physical blocks within the array. The SGFM will be unsecured if the erase verify command determines that the entire array is blank. After the next reset, the security

state of the SGFM will be determined by the FLASH security word, which, after being erased, will read 0xffff\_ffff, thus unsecuring the module.

### 10.10 Resets

The SGFM array is not accessible for any operations via the address and data buses during reset. If a reset occurs while any command is in progress that command will immediately abort. The state of any word being programmed or any erase pages/physical blocks being erased is not guaranteed.

### 10.11 Interrupts

The SGFM module can request an interrupt when all commands are completed or when the address, data, and command buffers are empty.

**Table 10-7. SGFM Interrupt Sources**

Interrupt Source	Interrupt Flag	Local Enable	Global Mask (PSR)
Command, data and address buffers empty	CBEIF (SGFMUSTAT)	CBEIE (SGFMMCR)	IE/FE bit
All commands are completed	CCIF (SGFMUSTAT)	CCIE (SGFMMCR)	IE/FE bit

**Figure 10-19** shows the SGFM interrupt mechanism. This system uses the CBEIE and CCIE bits as well as the register bank select signals to enable interrupt requests. By taking into account the selected register bank, false interrupt requests are not generated when the command buffer is empty in an unselected register bank.



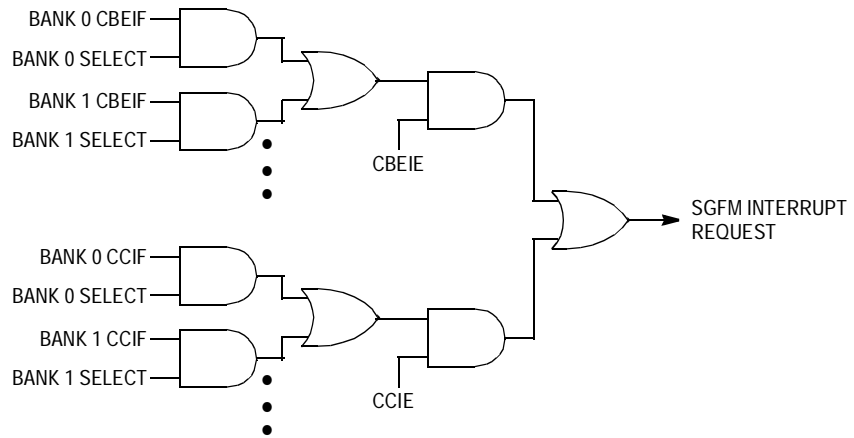

**Figure 10-19. SGFM Interrupt Implementation**



## Section 11. Clock Module

### 11.1 Contents

11.2	Introduction	244
11.3	Features	244
11.4	Modes of Operation	245
11.4.1	Normal PLL Mode	245
11.4.2	1:1 PLL Mode	245
11.4.3	External Clock Mode	245
11.4.4	Low-Power Options	245
11.4.4.1	Wait and Doze Modes	245
11.4.4.2	Stop Mode	246
11.5	Block Diagram	247
11.6	Signal Descriptions	248
11.6.1	EXTAL	248
11.6.2	XTAL	248
11.6.3	CLKOUT	248
11.6.4	PLLEN	248
11.6.5	RSTOUT	249
11.7	Memory Map and Registers	249
11.7.1	Module Memory Map	249
11.7.2	Register Descriptions	250
11.7.2.1	Synthesizer Control Register	250
11.7.2.2	Synthesizer Status Register	253
11.7.2.3	Synthesizer Test Register	256
11.7.2.4	Synthesizer Test Register 2	257
11.8	Functional Description	258
11.8.1	System Clock Modes	258
11.8.2	System Clocks Generation	259

11.8.3	PLL Lock Detection .....	259
11.8.3.1	PLL Loss of Lock Conditions .....	261
11.8.3.2	PLL Loss of Lock Reset .....	261
11.8.4	Loss of Clock Detection .....	261
11.8.4.1	Alternate Clock Selection .....	262
11.8.4.2	Loss-of-Clock Reset .....	265
11.8.5	Clock Operation During Reset .....	266
11.8.6	PLL Operation .....	266
11.8.6.1	Phase and Frequency Detector (PFD) .....	268
11.8.6.2	Charge Pump/Loop Filter .....	268
11.8.6.3	Voltage Control Output (VCO) .....	269
11.8.6.4	Multiplication Factor Divider (MFD) .....	269
11.9	Reset .....	269
11.10	Interrupts .....	269

## 11.2 Introduction

The clock module contains:

- Crystal oscillator (OSC)
- Phase-locked loop (PLL)
- Reduced frequency divider (RFD)
- Status and control registers
- Control logic

## 11.3 Features

Features of the clock module include:

- 2- to 10-MHz reference crystal oscillator
- Support for low-power modes
- Separate clock out signal

## 11.4 Modes of Operation

The clock module can be operated in normal PLL mode (default), 1:1 PLL mode, or external clock mode.

### 11.4.1 Normal PLL Mode

In normal PLL mode, the PLL is fully programmable. It can synthesize frequencies ranging from 2x to 9x the reference frequency and has a post divider capable of reducing this synthesized frequency without disturbing the PLL. The PLL reference can be either a crystal oscillator or an external clock.

### 11.4.2 1:1 PLL Mode

In 1:1 PLL mode, the PLL synthesizes a frequency equal to the external clock input reference frequency. The post divider is not active.

### 11.4.3 External Clock Mode

In external clock mode, the PLL is bypassed, and the external clock is applied to EXTAL. The resulting operating frequency is one-half the external clock frequency.

### 11.4.4 Low-Power Options

During wakeup from a low-power mode, the FLASH clock always clocks through at least 16 cycles before the CPU clocks are enabled. This allows the FLASH module time to recover from the low-power mode, and software can immediately resume fetching instructions from the memory.

#### 11.4.4.1 Wait and Doze Modes

In wait and doze modes, the system clocks to the peripherals are enabled, and the clocks to the CPU, FLASH, and SRAM are stopped. Each module can disable the module clocks locally at the module level.

#### 11.4.4.2 Stop Mode

In stop mode, all system clocks are disabled. There are several options for enabling/disabling the PLL and/or crystal oscillator in stop mode at the price of increased wakeup recovery time. The PLL can be disabled in stop mode, but then it requires a wakeup period before it can relock. The OSC can also be disabled during stop mode, but then it requires a wakeup period to restart.

When the PLL is enabled in stop mode (STPMD[1:0]), the external CLKOUT signal can support systems using CLKOUT as the clock source.

There is also a fast wakeup option for quickly enabling the system clocks during stop recovery. This eliminates the wakeup recovery time but at a risk of sending a potentially unstable clock to the system. To prevent a non-locked PLL frequency overshoot when using the fast wakeup option, change the RFD divisor to the current RFD value plus one before entering stop mode.

In external clock mode, there are no wakeup periods for OSC startup or PLL lock.

### 11.5 Block Diagram

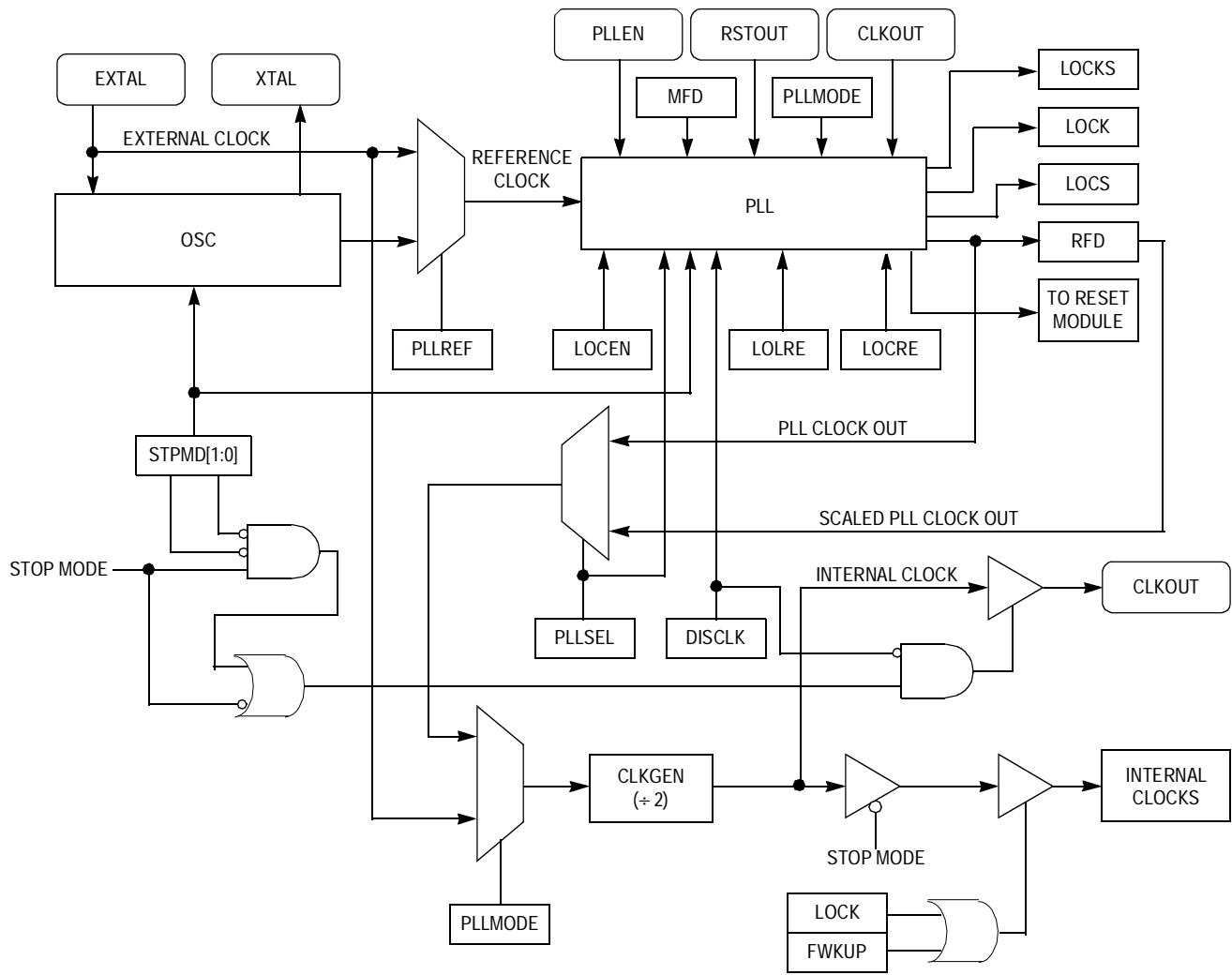

Figure 11-1. Clock Module Block Diagram

## 11.6 Signal Descriptions

The clock module signals are summarized in [Table 11-1](#) and a brief description follows. For more detailed information, refer to [Section 3. Signal Description](#).

**Table 11-1. Signal Properties**

Name	Function
EXTAL	Oscillator or clock input
XTAL	Oscillator output
CLKOUT	System clock output
PLLEN	PLL enable input
$\overline{\text{RSTOUT}}$	Reset signal from reset controller

### 11.6.1 EXTAL

This input is driven by an external clock except when used as a connection to the external crystal when using the internal oscillator.

### 11.6.2 XTAL

This output is an internal oscillator connection to the external crystal.

### 11.6.3 CLKOUT

This output reflects the internal system clock.

### 11.6.4 PLLEN

This input must be at  $V_{DD}$  potential to enable the PLL.



### 11.6.5 $\overline{\text{RSTOUT}}$

The  $\overline{\text{RSTOUT}}$  pin is asserted by:

- Internal system reset signal, or
- FRCRSTOUT bit in the Reset Control Status Register (RCR); see [5.6.1 Reset Control Register](#)

## 11.7 Memory Map and Registers

The clock programming model consists of these registers:

- Synthesizer Control Register (SYNCR) — Defines clock operation, refer to [11.7.2.1 Synthesizer Control Register](#)
- Synthesizer Status Register (SYNSR) — Reflects clock status, refer to [11.7.2.2 Synthesizer Status Register](#)
- Synthesizer Test Register (SYNTR) — Used for factory test, refer to [11.7.2.3 Synthesizer Test Register](#)
- Synthesizer Test Register 2 (SYNTR2) — Used only for factory test, refer to [11.7.2.4 Synthesizer Test Register 2](#)

### 11.7.1 Module Memory Map

**Table 11-2. Clock Module Memory Map**

Address	Register Name	Access <sup>(1)</sup>
0x00c3_0000	Synthesizer Control Register (SYNCR)	S
0x00c3_0002	Synthesizer Status Register (SYNSR)	S
0x00c3_0003	Synthesizer Test Register (SYNTR)	S
0x00c3_0004	Synthesizer Test Register 2 (SYNTR2)	S

1. S = CPU supervisor mode access only.

### 11.7.2 Register Descriptions

This subsection provides a description of the clock module registers.

#### 11.7.2.1 Synthesizer Control Register

The Synthesizer Control Register (SYNCR) is read/write always.

Address: 0x00c3\_0000 and 0x00c3\_0001

	Bit 15	14	13	12	11	10	9	Bit 8
Read:	LOLRE	MFD2	MFD1	MFD0	LOCRE	RFD2	RFD1	RFD0
Write:								
Reset:	0	0	1	0	0	0	0	1
	Bit 7	6	5	4	3	2	1	Bit 0
Read:	LOCEN	DISCLK	FWKUP	0	STMPD1	STMPD0	0	0
Write:								
Reset:	0	0	0	0	0	0	0	0

= Writes have no effect and the access terminates without a transfer error exception.

**Figure 11-2. Synthesizer Control Register (SYNCR)**

#### LOLRE — Loss of Lock Reset Enable Bit

The LOLRE bit determines how the system handles a loss of lock indication. When operating in normal mode or 1:1 PLL mode, the PLL must be locked before setting the LOLRE bit. Otherwise reset is immediately asserted. To prevent an immediate reset, the LOLRE bit must be cleared before writing the MFD[2:0] bits or entering stop mode with the PLL disabled.

- 1 = Reset on loss of lock
- 0 = No reset on loss of lock

**NOTE:** *In external clock mode, the LOLRE bit has no effect.*

**MFD[2:0]** — Multiplication Factor Divider Field

MFD[2:0] contain the binary value of the divider in the PLL feedback loop. See [Table 11-3](#). The MFD[2:0] value is the multiplication factor applied to the reference frequency. When MFD[2:0] are changed or the PLL is disabled in stop mode, the PLL loses lock. In 1:1 PLL mode, MFD[2:0] are ignored, and the multiplication factor is one.

**NOTE:** *In external clock mode, the MFD[2:0] bits have no effect. See [Table 11-6](#).*

**Table 11-3. System Frequency Multiplier of the Reference Frequency<sup>(1)</sup> in Normal PLL Mode**

		MFD[2:0]							
		000 <sup>(2)</sup> (2x)	001 (3x)	010 (4x) <sup>(3)</sup>	011 (5x)	100 (6x)	101 (7x)	110 (8x)	111 (9x)
<b>RFD[2:0]</b>	<b>000 (÷ 1)</b>	2	3	4	5	6	7	8	9
	<b>001 (÷ 2)<sup>(3)</sup></b>	1	3/2	2	5/2	3	7/2	4	9/2
	<b>010 (÷ 4)</b>	1/2	3/4	1	5/4	3/2	7/4	2	9/4
	<b>011 (÷ 8)</b>	1/4	3/8	1/2	5/8	3/4	7/8	1	9/8
	<b>100 (÷ 16)</b>	1/8	3/16	1/4	5/16	3/8	7/16	1/2	9/16
	<b>101 (÷ 32)</b>	1/16	3/32	1/8	5/32	3/16	7/32	1/4	9/32
	<b>110 (÷ 64)</b>	1/32	3/64	1/16	5/64	3/32	7/64	1/8	9/64
	<b>111 (÷ 128)</b>	1/64	3/128	1/32	5/128	3/64	7/128	1/16	9/128

1.  $f_{sys} = f_{ref} \times (MFD + 2)/2 \exp RFD$ ;  $f_{ref} \times (MFD + 2) \leq 80 \text{ MHz}$ ,  $f_{sys} \leq 33 \text{ MHz}$
2. MFD = 000 not valid for  $f_{ref} < 3 \text{ MHz}$
3. Default value out of reset

**LOCRES** — Loss of Clock Reset Enable Bit

The LOCRES bit determines how the system handles a loss of clock condition. When the LOCEN bit is clear, LOCRES has no effect. If the LOCS flag in SYNSR indicates a loss of clock condition, setting the LOCRES bit causes an immediate reset. To prevent an immediate reset, the LOCRES bit must be cleared before entering stop mode with the PLL disabled.

- 1 = Reset on loss of clock
- 0 = No reset on loss of clock

**NOTE:** *In external clock mode, the LOCRES bit has no effect.*

**RFD[2:0]** — Reduced Frequency Divider Field

The binary value written to RFD[2:0] is the PLL frequency divisor. See [Table 11-3](#). Changing RFD[2:0] does not affect the PLL or cause a relock delay. Changes in clock frequency are synchronized to the next falling edge of the current system clock. To avoid surpassing the allowable system operating frequency, write to RFD[2:0] only when the LOCK bit is set.

**NOTE:** *In external clock mode, the RFD[2:0] bits have no effect. See [Table 11-6](#).*

**LOCEN** — Loss of Clock Enable Bit

The LOCEN bit enables the loss of clock function. LOCEN does not affect the loss of lock function.

- 1 = Loss of clock function enabled
- 0 = Loss of clock function disabled

**NOTE:** *In external clock mode, the LOCEN bit has no effect.*

**DISCLK** — Disable CLKOUT Bit

The DISCLK bit determines whether CLKOUT is driven. Setting the DISCLK bit holds CLKOUT low.

- 1 = CLKOUT disabled
- 0 = CLKOUT enabled

**FWKUP** — Fast Wakeup Bit

The FWKUP bit determines when the system clocks are enabled during wakeup from stop mode.

- 1 = System clocks enabled on wakeup regardless of PLL lock status
- 0 = System clocks enabled only when PLL is locked or operating normally

**NOTE:** *When FWKUP = 0, if the PLL or OSC is enabled and unintentionally lost in stop mode, the PLL wakes up in self-clocked mode or reference clock mode depending on the clock that was lost.*

*In external clock mode, the FWKUP bit has no effect on the wakeup sequence.*

STPMD[1:0] — Stop Mode Bits

STPMD[1:0] control PLL and CLKOUT operation in stop mode as shown in [Table 11-4](#).

**Table 11-4. STPMD[1:0] Operation in Stop Mode**

STPMD[1:0]	Operation During Stop Mode			
	System Clocks	PLL	OSC	CLKOUT
00	Disabled	Enabled	Enabled	Enabled
01	Disabled	Enabled	Enabled	Disabled
10	Disabled	Disabled	Enabled	Disabled
11	Disabled	Disabled	Disabled	Disabled

11.7.2.2 Synthesizer Status Register

The Synthesizer Status Register (SYNSR) is a read-only register that can be read at any time. Writing to the SYNSR has no effect and terminates the cycle normally.

Address: 0x00c3\_0002

	Bit 7	6	5	4	3	2	1	Bit 0
Read:	PLLMODE	PLLSEL	PLLREF	LOCKS	LOCK	LOCS	0	0
Write:								
Reset:	Note 1	Note 1	Note 1	Note 2	Note 2	0	0	0

 = Writes have no effect and the access terminates without a transfer error exception.

Notes:

1. Reset state determined during reset configuration.
2. See the LOCKS and LOCK bit descriptions.

**Figure 11-3. Synthesizer Status Register (SYNSR)**

**PLLMODE — Clock Mode Bit**

The MODE bit is configured at reset and reflects the clock mode as shown in [Table 11-5](#).

- 1 = PLL clock mode
- 0 = External clock mode

**PLLSEL — PLL Select Bit**

The PLLSEL bit is configured at reset and reflects the PLL mode as shown in [Table 11-5](#).

- 1 = Normal PLL mode
- 0 = 1:1 PLL mode

**PLLREF — PLL Reference Bit**

The PLLREF bit is configured at reset and reflects the PLL reference source in normal PLL mode as shown in [Table 11-5](#).

- 1 = Crystal clock reference
- 0 = External clock reference

**Table 11-5. System Clock Modes**

PLLMODE:PLLSEL:PLLREF	Clock Mode
000	External clock mode
100	1:1 PLL mode
110	Normal PLL mode with external clock reference
111	Normal PLL mode with crystal oscillator reference

**LOCKS — Sticky PLL Lock Bit**

The LOCKS flag is a sticky indication of PLL lock status.

- 1 = No unintentional PLL loss of lock since last system reset or MFD change
- 0 = PLL loss of lock since last system reset or MFD change or currently not locked due to exit from STOP with FWKUP set

The lock detect function sets the LOCKS bit when the PLL achieves lock after:

- A system reset, or
- A write to SYNCR that changes the MFD[2:0] bits

When the PLL loses lock, LOCKS is cleared. When the PLL relocks, LOCKS remains cleared until one of the two listed events occurs.

In stop mode, if the PLL is intentionally disabled, then the LOCKS bit reflects the value prior to entering stop mode. However, if FWKUP is set, then LOCKS is cleared until the PLL regains lock. Once lock is regained, the LOCKS bit reflects the value prior to entering stop mode. Furthermore, reading the LOCKS bit at the same time that the PLL loses lock does not return the current loss of lock condition.

In external clock mode, LOCKS remains cleared after reset. In normal PLL mode and 1:1 PLL mode, LOCKS is set after reset.

#### LOCK — PLL Lock Flag

1 = PLL locked

0 = PLL not locked

The LOCK flag is set when the PLL is locked. PLL lock occurs when the synthesized frequency is within approximately 0.75 percent of the programmed frequency. The PLL loses lock when a frequency deviation of greater than approximately 1.5 percent occurs. Reading the LOCK flag at the same time that the PLL loses lock or acquires lock does not return the current condition of the PLL. The power-on reset circuit uses the LOCK bit as a condition for releasing reset.

If operating in external clock mode, LOCK remains cleared after reset.

#### LOCS — Sticky Loss Of Clock Flag

1 = Loss of clock detected since exiting reset or oscillator not yet recovered from exit from stop mode with FWKUP = 1

0 = Loss of clock not detected since exiting reset

The LOCS flag is a sticky indication of whether a loss of clock condition has occurred at any time since exiting reset in normal PLL and 1:1 PLL modes. LOCS = 0 when the system clocks are operating normally. LOCS = 1 when system clocks have failed due to a reference failure or PLL failure.

After entering stop mode with FWKUP set and the PLL and oscillator intentionally disabled (STPMD[1:0] = 11), the PLL exits stop mode in SCM while the oscillator starts up. During this time, LOCS is temporarily set regardless of LOCEN. It is cleared once the oscillator comes up and the PLL is attempting to lock.

If a read of the LOCS flag and a loss of clock condition occur simultaneously, the flag does not reflect the current loss of clock condition.

A loss of clock condition can be detected only if LOCEN = 1 or the oscillator has not yet returned from exit from stop mode with FWKUP = 1.

**NOTE:** The LOCS flag is always 0 in external clock mode.

### 11.7.2.3 Synthesizer Test Register

The Synthesizer Test Register (SYNTR) is only for factory testing. When not in test mode, SYNTR is read-only.

Address: 0x00c3\_0003

	Bit 7	6	5	4	3	2	1	Bit 0
Read:	0	0	0	0	0	0	0	0
Write:								
Reset:	0	0	0	0	0	0	0	0

= Writes have no effect and the access terminates without a transfer error exception.

**Figure 11-4. Synthesizer Test Register (SYNTR)**



11.7.2.4 Synthesizer Test Register 2

The Synthesizer Test Register 2 (SYNTR2) is only for factory testing.

Address: 0x00c3\_0004 through 0x00c3\_0007

	Bit 31	30	29	28	27	26	25	Bit 24
Read:	0	0	0	0	0	0	0	0
Write:								
Reset:	0	0	0	0	0	0	0	0
	Bit 23	22	21	20	19	18	17	Bit 16
Read:	0	0	0	0	0	0	0	0
Write:								
Reset:	0	0	0	0	0	0	0	0
	Bit 15	14	13	12	11	10	9	Bit 8
Read:	0	0	0	0	0	0	RSVD9	RSVD8
Write:								
Reset:	0	0	0	0	0	0	0	0
	Bit 7	6	5	4	3	2	1	Bit 0
Read:	RSVD7	RSVD6	RSVD5	RSVD4	RSVD3	RSVD2	RSVD1	RSVD0
Write:								
Reset:	0	0	0	0	0	0	0	0

= Writes have no effect and the access terminates without a transfer error exception.

**Figure 11-5. Synthesizer Test Register 2 (SYNTR2)**

**Bits 31–10**

Bits 31–10 are read-only. Writing to bits 31–10 has no effect.

**RSVD9–RSVD0 — Reserved**

The RSVD bits can be read at any time. Writes to these bits update the register values but have no effect on functionality.

## 11.8 Functional Description

This subsection provides a functional description of the clock module.

### 11.8.1 System Clock Modes

The system clock source is determined during reset (see [Table 4-7. Configuration During Reset](#)). The value of PLEN is latched during reset and is of no importance after reset is negated. If PLEN is changed during a reset other than power-on reset, the internal clocks may glitch as the clock source is changed between external clock mode and PLL clock mode. Whenever PLEN is changed in reset, an immediate loss of lock condition occurs.

[Table 11-6](#) shows the clock-out frequency to clock-in frequency relationships for the possible clock modes.

**Table 11-6. Clock-Out and Clock-In Relationships**

Clock Mode	PLL Options <sup>(1)</sup>
Normal PLL clock mode	$f_{\text{sys}} = f_{\text{ref}} \times (\text{MFD} + 2)/2^{\text{RFD}}$
1:1 PLL clock mode	$f_{\text{sys}} = f_{\text{ref}}$
External clock mode	$f_{\text{sys}} = f_{\text{ref}}/2$

- $f_{\text{ref}}$  = input reference frequency  
 $f_{\text{sys}}$  = CLKOUT frequency  
 MFD ranges from 0 to 7.  
 RFD ranges from 0 to 7.

**CAUTION:** *XTAL must be tied low in external clock mode when reset is asserted. If it is not, clocks could be suspended indefinitely.*

The external clock is divided by two internally to produce the system clocks.

## 11.8.2 System Clocks Generation

In normal PLL clock mode, the default system frequency is two times the reference frequency after reset. The RFD[2:0] and MFD[2:0] bits in SYNCR select the frequency multiplier.

When programming the PLL, do not exceed the maximum system clock frequency listed in the electrical specifications. Use this procedure to accommodate the frequency overshoot that occurs when the MFD bits are changed:

1. Determine the appropriate value for the MFD and RFD fields in SYNCR. The amount of jitter in the system clocks can be minimized by selecting the maximum MFD factor that can be paired with an RFD factor to provide the required frequency.
2. Write a value of RFD (from step 1) + 1 to the RFD field of SYNCR.
3. Write the MFD value from step 1 to SYNCR.
4. Monitor the LOCK flag in SYNSR. When the PLL achieves lock, write the RFD value from step 1 to the RFD field of SYNCR. This changes the system clocks frequency to the required frequency.

**NOTE:** *Keep the maximum system clock frequency below the limit given in [Section 23. Preliminary Electrical Specifications](#).*

## 11.8.3 PLL Lock Detection

The lock detect logic monitors the reference frequency and the PLL feedback frequency to determine when frequency lock is achieved. Phase lock is inferred by the frequency relationship, but is not guaranteed. The LOCK flag in SYNSR reflects the PLL lock status. A sticky lock flag, LOCKS, is also provided.

The lock detect function uses two counters. One is clocked by the reference and the other is clocked by the PLL feedback. When the reference counter has counted N cycles, its count is compared to that of the feedback counter. If the feedback counter has also counted N cycles, the process is repeated for N + K counts. Then, if the two counters still match, the lock criteria is relaxed by 1/2 and the system is notified that the PLL has achieved frequency lock.

After lock is detected, the lock circuit continues to monitor the reference and feedback frequencies using the alternate count and compare process. If the counters do not match at any comparison time, then the LOCK flag is cleared to indicate that the PLL has lost lock. At this point, the lock criteria is tightened and the lock detect process is repeated.

The alternate count sequences prevent false lock detects due to frequency aliasing while the PLL tries to lock. Alternating between tight and relaxed lock criteria prevents the lock detect function from randomly toggling between locked and non-locked status due to phase sensitivities. **Figure 11-6** shows the sequence for detecting locked and non-locked conditions.

In external clock mode, the PLL is disabled and cannot lock.

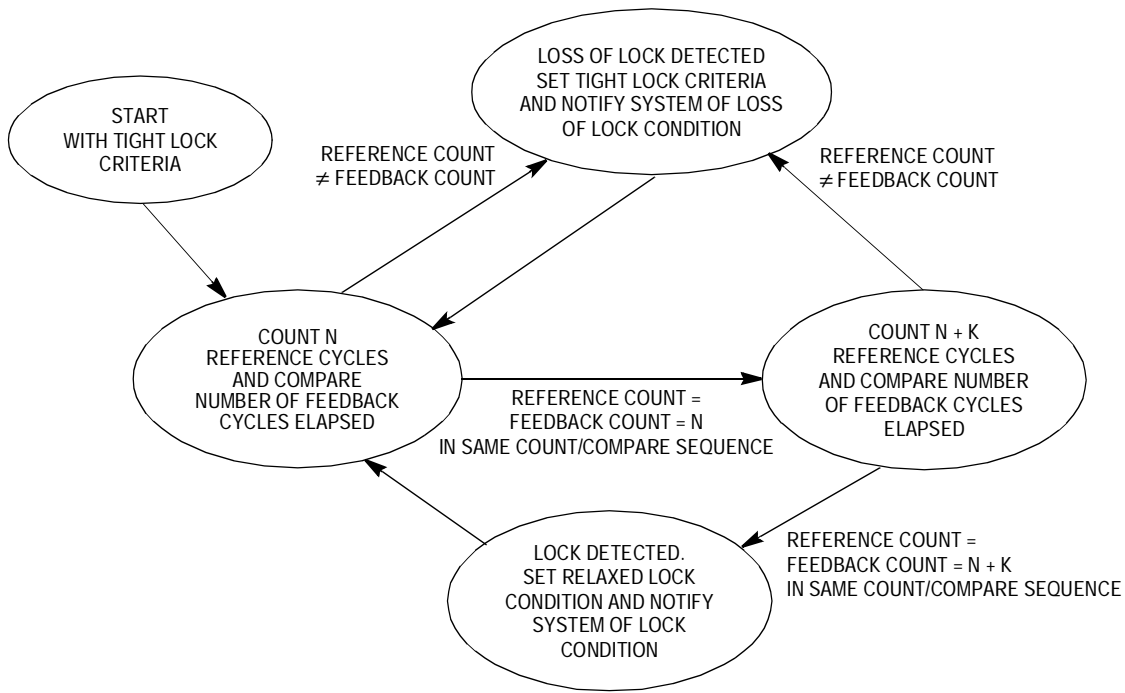

Figure 11-6. Lock Detect Sequence

### 11.8.3.1 PLL Loss of Lock Conditions

Once the PLL acquires lock after reset, the LOCK and LOCKS flags are set. If the MFD is changed, or if an unexpected loss of lock condition occurs, the LOCK and LOCKS flags are negated. While the PLL is in the non-locked condition, the system clocks continue to be sourced from the PLL as the PLL attempts to relock. Consequently, during the relocking process, the system clocks frequency is not well defined and may exceed the maximum system frequency, violating the system clock timing specifications.

However, once the PLL has relocked, the LOCK flag is set. The LOCKS flag remains cleared if the loss of lock is unexpected. The LOCKS flag is set when the loss of lock is caused by changing MFD. If the PLL is intentionally disabled during stop mode, then after exit from stop mode, the LOCKS flag reflects the value prior to entering stop mode once lock is regained.

### 11.8.3.2 PLL Loss of Lock Reset

If the LOLRE bit in SYNCR is set, a loss of lock condition asserts reset. Reset reinitializes the LOCK and LOCKS flags. Therefore, software must read the LOL bit in Reset Status Register (RSR) to determine if a loss of lock caused the reset. See [5.6.2 Reset Status Register](#).

To exit reset in PLL mode, the reference must be present, and the PLL must achieve lock.

In external clock mode, the PLL cannot lock. Therefore, a loss of lock condition cannot occur, and the LOLRE bit has no effect.

## 11.8.4 Loss of Clock Detection

The LOCEN bit in SYNCR enables the loss of clock detection circuit to monitor the input clocks to the phase and frequency detector (PFD). When either the reference or feedback clock frequency falls below the minimum frequency, the loss of clock circuit sets the sticky LOCS flag in SYNSR.

**NOTE:** *In external clock mode, the loss of clock circuit is disabled.*

### 11.8.4.1 Alternate Clock Selection

Depending on which clock source fails, the loss-of-clock circuit switches the system clocks source to the remaining operational clock. The alternate clock source generates the system clocks until reset is asserted. As [Table 11-7](#) shows, if the reference fails, the PLL goes out of lock and into self-clocked mode (SCM). The PLL remains in SCM until the next reset. When the PLL is operating in SCM, the system frequency depends on the value in the RFD field. The SCM system frequency stated in electrical specifications assumes that the RFD has been programmed to binary 000. If the loss-of-clock condition is due to PLL failure, the PLL reference becomes the system clocks source until the next reset, even if the PLL regains and rellocks.

**Table 11-7. Loss of Clock Summary**

Clock Mode	System Clock Source Before Failure	Reference Failure Alternate Clock Selected by LOC Circuit <sup>(1)</sup> Until Reset	PLL Failure Alternate Clock Selected by LOC Circuit Until Reset
PLL	PLL	PLL self-clocked mode	PLL reference
External	External clock	None	NA

1. The LOC circuit monitors the reference and feedback inputs to the PFD. See [Figure 11-8](#).

A special loss-of-clock condition occurs when both the reference and the PLL fail. The failures may be simultaneous, or the PLL may fail first. In either case, the reference clock failure takes priority and the PLL attempts to operate in SCM. If successful, the PLL remains in SCM until the next reset. If the PLL cannot operate in SCM, the system remains static until the next reset. Both the reference and the PLL must be functioning properly to exit reset.

**Table 11-8. Stop Mode Operation (Sheet 1 of 3)**

MODE In	LOCEN	LOCRE	LOLRE	PLL	OSC	FWKUP	Expected PLL Action at Stop	PLL Action During Stop	MODE Out	LOCKS	LOCK	LOCS	Comments
EXT	X	X	X	X	X	X	—	—	EXT	0	0	0	
								Lose reference clock	Stuck	—	—	—	
NRM	0	0	0	Off	Off	0	Lose lock, f.b. clock, reference clock	Regain	NRM	'LK	1	'LC	
								No regain	Stuck	—	—	—	
NRM	X	0	0	Off	Off	1	Lose lock, f.b. clock, reference clock	Regain clocks, but don't regain lock	SCM-> unstable NRM	0->'LK	0->1	1->'LC	Block LOCS and LOCKS until clock and lock respectively regain; enter SCM regardless of LOCEN bit until reference regained
								No reference clock regain	SCM->	0->	0->	1->	Block LOCS and LOCKS until clock and lock respectively regain; enter SCM regardless of LOCEN bit
								No f.b. clock regain	Stuck	—	—	—	
NRM	0	0	0	Off	On	0	Lose lock	Regain	NRM	'LK	1	'LC	Block LOCKS from being cleared
								Lose reference clock or no lock regain	Stuck	—	—	—	
								Lose reference clock, regain	NRM	'LK	1	'LC	Block LOCKS from being cleared
NRM	0	0	0	Off	On	1	Lose lock	No lock regain	Unstable NRM	0->'LK	0->1	'LC	Block LOCKS until lock regained
								Lose reference clock or no f.b. clock regain	Stuck	—	—	—	
								Lose reference clock, regain	Unstable NRM	0->'LK	0->1	'LC	LOCS not set because LOCEN = 0
NRM	0	0	0	On	On	0	—	—	NRM	'LK	1	'LC	
								Lose lock or clock	Stuck	—	—	—	
								Lose lock, regain	NRM	0	1	'LC	
								Lose clock and lock, regain	NRM	0	1	'LC	LOCS not set because LOCEN = 0
NRM	0	0	0	On	On	1	—	—	NRM	'LK	1	'LC	
								Lose lock	Unstable NRM	0	0->1	'LC	
								Lose lock, regain	NRM	0	1	'LC	
								Lose clock	Stuck	—	—	—	
								Lose clock, regain without lock	Unstable NRM	0	0->1	'LC	
								Lose clock, regain with lock	NRM	0	1	'LC	

**Clock Module**
**Table 11-8. Stop Mode Operation (Sheet 2 of 3)**

MODE In	LOCEN	LOCRE	LOLRE	PLL	OSC	FWKUP	Expected PLL Action at Stop	PLL Action During Stop	MODE Out	LOCKS	LOCK	LOCS	Comments
NRM	X	X	1	Off	X	X	Lose lock, f.b. clock, reference clock	RESET	RESET	—	—	—	Reset immediately
NRM	0	0	1	On	On	X	—	—	NRM	'LK	1	'LC	
								Lose lock or clock	RESET	—	—	—	Reset immediately
NRM	1	0	0	Off	Off	0	Lose lock, f.b. clock, reference clock	Regain	NRM	'LK	1	'LC	REF not entered during stop; SCM entered during stop only during OSC startup
								No regain	Stuck	—	—	—	
NRM	1	0	0	Off	On	0	Lose lock, f.b. clock	Regain	NRM	'LK	1	'LC	REF mode not entered during stop
								No f.b. clock or lock regain	Stuck	—	—	—	
								Lose reference clock	SCM	0	0	1	Wakeup without lock
NRM	1	0	0	Off	On	1	Lose lock, f.b. clock	Regain f.b. clock	Unstable NRM	0->'LK	0->1	'LC	REF mode not entered during stop
								No f.b. clock regain	Stuck	—	—	—	
								Lose reference clock	SCM	0	0	1	Wakeup without lock
NRM	1	0	0	On	On	0	—	—	NRM	'LK	1	'LC	
								Lose reference clock	SCM	0	0	1	Wakeup without lock
								Lose f.b. clock	REF	0	X	1	Wakeup without lock
								Lose lock	Stuck	—	—	—	
								Lose lock, regain	NRM	0	1	'LC	
NRM	1	0	0	On	On	1	—	—	NRM	'LK	1	'LC	
								Lose reference clock	SCM	0	0	1	Wakeup without lock
								Lose f.b. clock	REF	0	X	1	Wakeup without lock
								Lose lock	Unstable NRM	0	0->1	'LC	
NRM	1	0	1	On	On	X	—	—	NRM	'LK	1	'LC	
								Lose lock or clock	RESET	—	—	—	Reset immediately
NRM	1	1	X	Off	X	X	Lose lock, f.b. clock, reference clock	RESET	RESET	—	—	—	Reset immediately
NRM	1	1	0	On	On	0	—	—	NRM	'LK	1	'LC	
								Lose clock	RESET	—	—	—	Reset immediately
								Lose lock	Stuck	—	—	—	
								Lose lock, regain	NRM	0	1	'LC	



**Table 11-8. Stop Mode Operation (Sheet 3 of 3)**

MODE In	LOCEN	LOCRE	LOLRE	PLL	OSC	FWKUP	Expected PLL Action at Stop	PLL Action During Stop	MODE Out	LOCKS	LOCK	LOCS	Comments
NRM	1	1	0	On	On	1	—	—	NRM	'LK	1	'LC	
								Lose clock	RESET	—	—	—	Reset immediately
								Lose lock	Unstable NRM	0	0->1	'LC	
								Lose lock, regain	NRM	0	1	'LC	
NRM	1	1	1	On	On	X	—	—	NRM	'LK	1	'LC	
								Lose clock or lock	RESET	—	—	—	Reset immediately
REF	1	0	0	X	X	X	—	—	REF	0	X	1	
								Lose reference clock	Stuck	—	—	—	
SCM	1	0	0	Off	X	0	PLL disabled	Regain SCM	SCM	0	0	1	Wakeup without lock
SCM	1	0	0	Off	X	1	PLL disabled	Regain SCM	SCM	0	0	1	
SCM	1	0	0	On	On	0	—	—	SCM	0	0	1	Wakeup without lock
								Lose reference clock	SCM				
SCM	1	0	0	On	On	1	—	—	SCM	0	0	1	
								Lose reference clock	SCM				

PLL = PLL enabled during STOP mode. PLL = On when STPMD[1:0] = 00 or 01  
 OSC = OSC enabled during STOP mode. OSC = On when STPMD[1:0] = 00, 01, or 10

**MODES**

- NRM = normal PLL crystal clock reference or normal PLL external reference or PLL 1:1 mode. During PLL 1:1 or normal external reference mode, the oscillator is never enabled. Therefore, during these modes, refer to the OSC = On case regardless of STPMD values.
- EXT = external clock mode
- REF = PLL reference mode due to losing PLL clock or lock from NRM mode
- SCM = PLL self-clocked mode due to losing reference clock from NRM mode
- RESET = immediate reset

**LOCKS**

- 'LK = expecting previous value of LOCKS before entering stop
- 0->'LK = current value is 0 until lock is regained which then will be the previous value before entering stop
- 0-> = current value is 0 until lock is regained but lock is never expected to regain

**LOCS**

- 'LC = expecting previous value of LOCS before entering stop
- 1->'LC = current value is 1 until clock is regained which then will be the previous value before entering stop
- 1-> = current value is 1 until clock is regained but CLK is never expected to regain

**11.8.4.2 Loss-of-Clock Reset**

When a loss-of-clock condition is recognized, reset is asserted if the LOCRES bit in SYNCR is set. The LOCS bit in SYNCR is cleared after reset. Therefore, the LOCRES bit must be read in RSR to determine that a loss of clock condition occurred. LOCRES has no effect in external clock mode.

To exit reset in PLL mode, the reference must be present, and the PLL must acquire lock.

### 11.8.5 Clock Operation During Reset

In external clock mode, the system is static and does not recognize reset until a clock is applied to EXTAL.

In PLL mode, the PLL operates in self-clocked mode (SCM) during reset until the input reference clock to the PLL begins operating within the limits given in the electrical specifications.

If a PLL failure causes a reset, the system enters reset using the reference clock. Then the clock source changes to the PLL operating in SCM. If SCM is not functional, the system becomes static. Alternately, if the LOCEN bit in SYNCR is clear when the PLL fails, the system becomes static. If external reset is asserted, the system cannot enter reset unless the PLL is capable of operating in SCM.

### 11.8.6 PLL Operation

In PLL mode, the PLL synthesizes the system clocks. The PLL can multiply the reference clock frequency by 2x to 9x, provided that the system clock (CLKOUT) frequency remains within the range listed in electrical specifications. For example, if the reference frequency is 2 MHz, the PLL can synthesize frequencies of 4 MHz to 18 MHz. In addition, the RFD can reduce the system frequency by dividing the output of the PLL. The RFD is not in the feedback loop of the PLL, so changing the RFD divisor does not affect PLL operation.

**Figure 11-8** shows the external support circuitry for the crystal oscillator with example component values. Actual component values depend on crystal specifications.

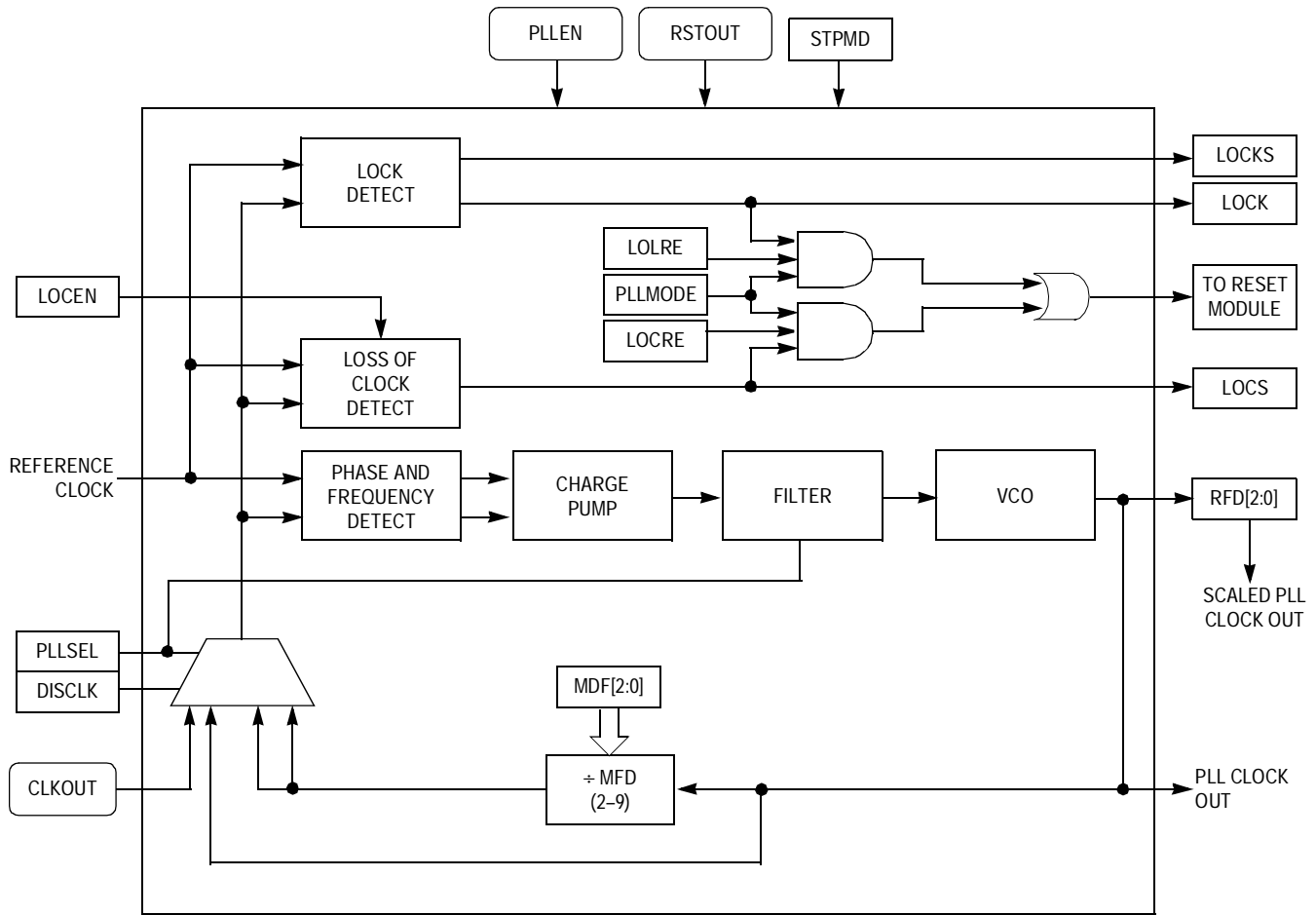

Figure 11-7. PLL Block Diagram

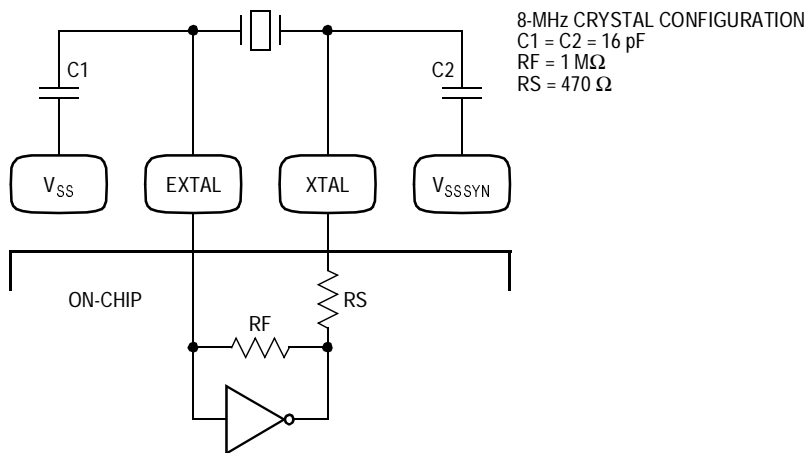

Figure 11-8. Crystal Oscillator Example

11.8.6.1 Phase and Frequency Detector (PFD)

The PFD is a dual-latch phase-frequency detector. It compares both the phase and frequency of the reference and feedback clocks. The reference clock comes from either the crystal oscillator or an external clock source. The feedback clock comes from:

- CLKOUT in 1:1 PLL mode, or
- VCO output divided by two if CLKOUT is disabled in 1:1 PLL mode, or
- VCO output divided by the MFD in normal PLL mode

When the frequency of the feedback clock equals the frequency of the reference clock, the PLL is frequency-locked. If the falling edge of the feedback clock lags the falling edge of the reference clock, the PFD pulses the UP signal. If the falling edge of the feedback clock leads the falling edge of the reference clock, the PFD pulses the DOWN signal. The width of these pulses relative to the reference clock depends on how much the two clocks lead or lag each other. Once phase lock is achieved, the PFD continues to pulse the UP and DOWN signals for very short durations during each reference clock cycle. These short pulses continually update the PLL and prevent the frequency drift phenomenon known as dead-banding.

11.8.6.2 Charge Pump/Loop Filter

In 1:1 PLL mode, the charge pump uses a fixed current. In normal mode the current magnitude of the charge pump varies with the MFD as shown in [Table 11-9](#).

**Table 11-9. Charge Pump Current and MFD in Normal Mode Operation**

Charge Pump Current	MFD
1X	$0 \leq \text{MFD} < 2$
2X	$2 \leq \text{MFD} < 6$
4X	$6 \leq \text{MFD}$

The UP and DOWN signals from the PFD control whether the charge pump applies or removes charge, respectively, from the loop filter. The filter is integrated on the chip.

#### 11.8.6.3 Voltage Control Output (VCO)

The voltage across the loop filter controls the frequency of the VCO output. The frequency-to-voltage relationship (VCO gain) is positive, and the output frequency is four times the target system frequency.

#### 11.8.6.4 Multiplication Factor Divider (MFD)

When the PLL is not in 1:1 PLL mode, the MFD divides the output of the VCO and feeds it back to the PFD. The PFD controls the VCO frequency via the charge pump and loop filter such that the reference and feedback clocks have the same frequency and phase. Thus, the frequency of the input to the MFD, which is also the output of the VCO, is the reference frequency multiplied by the same amount that the MFD divides by. For example, if the MFD divides the VCO frequency by six, the PLL is frequency locked when the VCO frequency is six times the reference frequency. The presence of the MFD in the loop allows the PLL to perform frequency multiplication, or synthesis.

In 1:1 PLL mode, the MFD is bypassed, and the effective multiplication factor is one.

## 11.9 Reset

The clock module can assert a reset when a loss of clock or loss of lock occurs as described in [11.8 Functional Description](#).

Reset initializes the clock module registers to a known startup state as described in [11.7 Memory Map and Registers](#).

## 11.10 Interrupts

The clock module does not generate interrupt requests.



## Section 12. Ports Module

### 12.1 Contents

12.2	Introduction .....	272
12.3	Signals .....	273
12.4	Memory Map and Registers .....	273
12.4.1	Memory Map .....	274
12.4.2	Register Descriptions .....	275
12.4.2.1	Port Output Data Registers .....	275
12.4.2.2	Port Data Direction Registers .....	276
12.4.2.3	Port Pin Data/Set Data Registers .....	277
12.4.2.4	Port Clear Output Data Registers .....	278
12.4.2.5	Port C/D Pin Assignment Register .....	279
12.4.2.6	Port E Pin Assignment Register .....	280
12.5	Functional Description .....	281
12.5.1	Pin Functions .....	282
12.5.2	Port Digital I/O Timing .....	283
12.6	Interrupts .....	283

## 12.2 Introduction

Many of the pins associated with the external interface may be used for several different functions. Their primary function is to provide an external interface to access off-chip resources. When not used for their primary functions, many of the pins may be used as general purpose digital input/output (I/O) pins. In some cases, the pin function is set by the operating mode, and the alternate pin functions are not supported.

To facilitate the general purpose digital I/O function, these pins are grouped into 8-bit ports. Each port has registers that configure the pins for the desired function, monitor the pins, and control the pins within the ports.

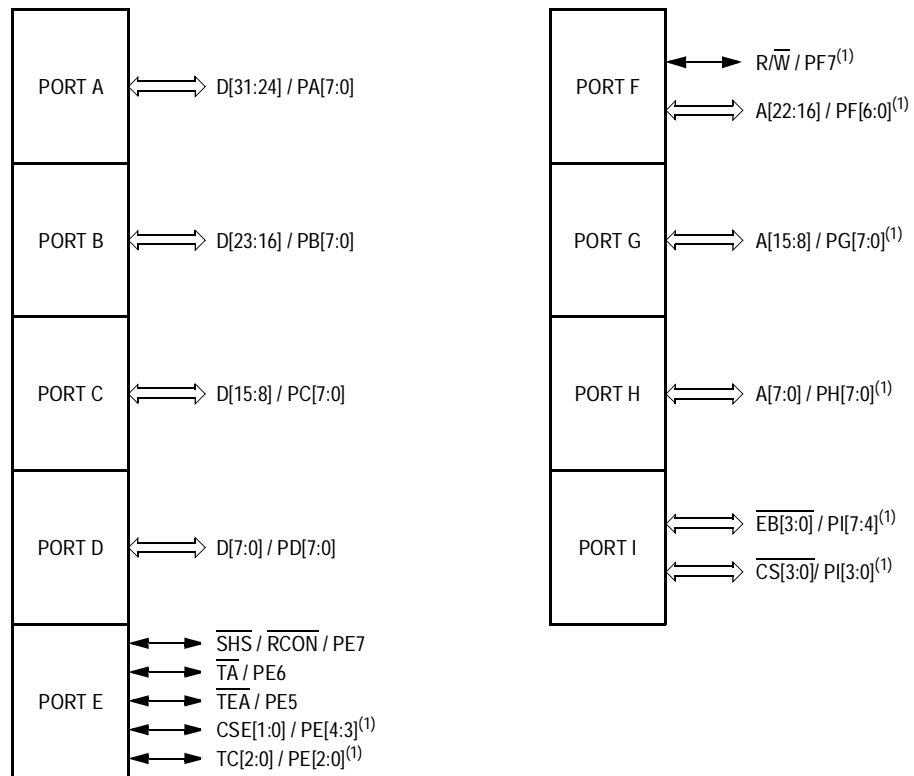

Note 1. These pins are found only on the 144-pin package.

Figure 12-1. Ports Module Block Diagram



## 12.3 Signals

See [Table 12-3](#) in [12.5 Functional Description](#) for signal location and naming convention.

## 12.4 Memory Map and Registers

The ports programming model consists of these registers:

- The port output data registers (PORTx) store the data to be driven on the corresponding port pins when the pins are configured for digital output.
- The port data direction registers (DDRx) control the direction of the port pin drivers when the pins are configured for digital I/O.
- Port pin data/set data registers (PORTxP/SETx):
  - Reflect the current state of the port pins
  - Allow for setting individual bits in PORTx
- The port clear output data registers (CLR<sub>x</sub>) allow for clearing individual bits in PORTx.
- The port pin assignment registers (PCDPAR and PEPAR) control the function of each pin of the C, D, E, I7, and I6 ports.

In emulation mode, accesses to the port registers are ignored and the port access goes external so that emulation hardware can satisfy the port access request. The cycle termination is always provided by the port logic, even in emulation mode.

All port registers are word-, half-word, and byte-accessible and are grouped to allow coherent access to port data register groups. Writing to reserved bits in the port registers has no effect and reading returns 0s.

The I/O ports have a base address of 0x00c0\_0000.

**12.4.1 Memory Map**
**Table 12-1. I/O Port Module Memory Map**

Address	Bits 31–24	Bits 23–16	Bits 15–8	Bits 7–0	Access <sup>(1)</sup>
0x00c0_0000	PORTA	PORTB	PORTC	PORTD	S/U
0x00c0_0004	PORTE	PORTF	PORTG	PORTH	S/U
0x00c0_0008	PORTI	Reserved <sup>(2)</sup>			S/U
0x00c0_000c	DDRA	DDRB	DDRC	DDRD	S/U
0x00c0_0010	DDRE	DDRF	DDRG	DDRH	S/U
0x00c0_0014	DDRI	Reserved <sup>(2)</sup>			S/U
0x00c0_0018	PORTAP/SETA	PORTBP/SETB	PORTCP/SETC	PORTDP/SETD	S/U
0x00c0_001c	PORTEP/SETE	PORTFP/SETF	PORTGP/SETG	PORTHP/SETH	S/U
0x00c0_0020	PORTIP/SETI	Reserved <sup>(2)</sup>			S/U
0x00c0_0024	CLRA	CLRB	CLRC	CLRD	S/U
0x00c0_0028	CLRE	CLRF	CLRG	CLRH	S/U
0x00c0_002c	CLRI	Reserved <sup>(2)</sup>			S/U
0x00c0_0030	PCDPAR	PEPAR	Reserved <sup>(2)</sup>		S/U
0x00c0_0034– 0x00c0_003c	Reserved <sup>(2)</sup>				S/U

1. S/U = CPU supervisor or user mode access. User mode accesses to supervisor only addresses have no effect and result in a cycle termination transfer error.
2. Writes have no effect, reads return 0s, and the access terminates without a transfer error exception.

## 12.4.2 Register Descriptions

This subsection provides a description of the I/O port registers.

### 12.4.2.1 Port Output Data Registers

The port output data registers (PORTx) store the data to be driven on the corresponding port x pins when the pins are configured for digital output. Reading PORTx returns the current value in the register, not the port x pin values.

The SETx and CLRx registers also affect the PORTx register bits. To set bits in PORTx, write 1s to the corresponding bits in PORTxP/SETx. To clear bits in PORTx, write 0s to the corresponding bits in CLRx.

PORTx are read/write registers when not in emulation mode. Reset sets PORTx.

Address: 0x00c0\_0000 — PORTA  
 0x00c0\_0001 — PORTB  
 0x00c0\_0002 — PORTC  
 0x00c0\_0003 — PORTD  
 0x00c0\_0004 — PORTE  
 0x00c0\_0005 — PORTF  
 0x00c0\_0006 — PORTG  
 0x00c0\_0007 — PORTH  
 0x00c0\_0008 — PORTI

	7	6	5	4	3	2	1	Bit 0
Read:	PORTx7	PORTx6	PORTx5	PORTx4	PORTx3	PORTx2	PORTx1	PORTx0
Write:								
Reset:	1	1	1	1	1	1	1	1

**Figure 12-2. Port Output Data Registers (PORTx)**

12.4.2.2 Port Data Direction Registers

A port data direction registers (DDR<sub>x</sub>) control the direction of the port x pin drivers when the pins are configured for digital I/O. Setting any bit in DDR<sub>x</sub> configures the corresponding port x pin as an output. Clearing any bit in DDR<sub>x</sub> configures the corresponding pin as an input. When a pin is not configured for digital I/O, its corresponding data direction bit has no effect.

DDR<sub>x</sub> are read/write registers when not in emulation mode. Reset clears DDR<sub>x</sub>.

- Address: 0x00c0\_000c — DDRA
- 0x00c0\_000d — DDRB
- 0x00c0\_000e — DDRC
- 0x00c0\_000f — DDRD
- 0x00c0\_0010 — DDRE
- 0x00c0\_0011 — DDRF
- 0x00c0\_0012 — DDRG
- 0x00c0\_0013 — DDRH
- 0x00c0\_0014 — DDRI

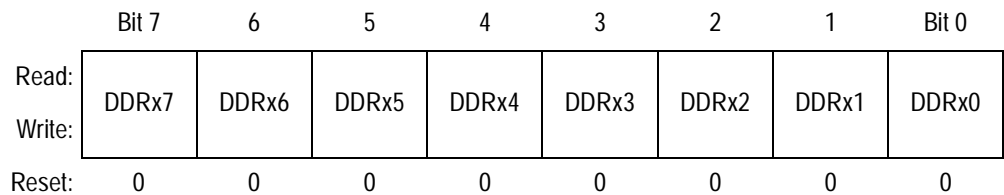

**Figure 12-3. Port Data Direction Registers (DDR<sub>x</sub>)**

DDR<sub>x</sub>[7:0] — Port x Data Direction Bits

1 = Pin configured as output

0 = Pin configured as input

### 12.4.2.3 Port Pin Data/Set Data Registers

Reading a Port Pin Data/Set Data Register (PORTxP/SETx) returns the current state of the port x pins.

Writing 1s to PORTxP/SETx sets the corresponding bits in PORTx. Writing 0s has no effect.

PORTxP/SETx are read/write registers when not in emulation mode.

Address: 0x00c0\_0018 — PORTAP/SETA  
 0x00c0\_0019 — PORTBP/SETB  
 0x00c0\_001a — PORTCP/SETC  
 0x00c0\_001b — PORTDP/SETD  
 0x00c0\_001c — PORTEP/SETE  
 0x00c0\_001d — PORTFP/SETF  
 0x00c0\_001e — PORTGP/SETG  
 0x00c0\_001f — PORTHP/SETH  
 0x00c0\_0020 — PORTIP/SETI

	Bit 7	6	5	4	3	2	1	Bit 0
Read:	PORTxP7	PORTxP6	PORTxP5	PORTxP4	PORTxP3	PORTxP2	PORTxP1	PORTxP0
Write:	SETx7	SETx6	SETx5	SETx4	SETx3	SETx2	SETx1	SETx0
Reset:	P	P	P	P	P	P	P	P

P = Current pin state

**Figure 12-4. Port Pin Data/Set Data Registers (PORTxP/SETx)**

12.4.2.4 Port Clear Output Data Registers

Writing 0s to a Port Clear Output Data Register (CLR<sub>x</sub>) clears the corresponding bits in PORT<sub>x</sub>. Writing 1s has no effect. Reading CLR<sub>x</sub> returns 0s.

CLR<sub>x</sub> are read/write registers when not in emulation mode.

Address: 0x00c0\_0024 — CLRA  
 0x00c0\_0025 — CLRB  
 0x00c0\_0026 — CLRC  
 0x00c0\_0027 — CLRD  
 0x00c0\_0028 — CLRE  
 0x00c0\_0029 — CLRF  
 0x00c0\_002a — CLRG  
 0x00c0\_002b — CLRH  
 0x00c0\_002c — CLRI

	Bit 7	6	5	4	3	2	1	Bit 0
Read:	0	0	0	0	0	0	0	0
Write:	CLR <sub>x</sub> 7	CLR <sub>x</sub> 6	CLR <sub>x</sub> 5	CLR <sub>x</sub> 4	CLR <sub>x</sub> 3	CLR <sub>x</sub> 2	CLR <sub>x</sub> 1	CLR <sub>x</sub> 0
Reset:	0	0	0	0	0	0	0	0

**Figure 12-5. Port Clear Output Data Registers (CLR<sub>x</sub>)**

12.4.2.5 Port C/D Pin Assignment Register

The Port C/D Pin Assignment Register (PCDPAR) controls the pin function of ports C, D, I7, and I6.

PCDPAR is a read/write register when not in emulation mode.

Address: 0x00c0\_0030

	Bit 7	6	5	4	3	2	1	Bit 0
Read:	PCDPA	0	0	0	0	0	0	0
Write:								
Reset:	See note	0	0	0	0	0	0	0

= Writes have no effect and the access terminates without a transfer error exception.

Note: Reset state determined during reset configuration. PCDPA = 1 except in single-chip mode or when an external boot device is selected with a 16-bit port size in master mode.

**Figure 12-6. Port C, D, I7, and I6 Pin Assignment Register (PCDPAR)**

PCDPA — Port C, D, I7, and I6 Pin Assignment Bit

1 = Port C, D, I7, and I6 pins configured for primary function

0 = Port C, D, I7, and I6 pins configured for digital I/O

12.4.2.6 Port E Pin Assignment Register

The Port E Pin Assignment Register (PEPAR) controls the pin function of port E.

PEPAR is a read/write register when not in emulation mode.

Address: 0x00c0\_0031

	Bit 7	6	5	4	3	2	1	Bit 0
Read:	PEPA7	PEPA6	PEPA5	PEPA4	PEPA3	PEPA2	PEPA1	PEPA0
Write:								
Reset:	See note							

Note: Reset state determined during reset configuration as shown in [Table 12-2](#).

**Figure 12-7. Port E Pin Assignment Register (PEPAR)**

PEPA[7:0] — Port E Pin Assignment Bits

1 = Port E pins configured for primary function

0 = Port E pins configured for digital I/O

**Table 12-2. PEPAR Reset Values**

PEPAR	Pin	Master Mode	Single-Chip Mode	Emulation Mode
PEPA7	$\overline{SHS}$	1	0	1
PEPA6	$\overline{TA}$	1	0	1
PEPA5	$\overline{TEA}$	1	0	1
PEPA[4:3]	CSE[1:0]	0	0	1
PEPA[2:0]	TC[2:0]	0	0	1



## 12.5 Functional Description

The initial pin function is determined during reset configuration (see [Section 4. Chip Configuration Module \(CCM\)](#)). The pin assignment registers (PCDPAR and PEPAR) allow the user to select between digital I/O or another pin function after reset.

In single-chip mode, all pins are configured as digital I/O by default.

Every digital I/O pin is individually configurable as an input or an output via a data direction register (DDRx).

Every port has an output data register (PORTx) and a pin data register (PORTxP/SETx) to monitor and control the state of its pins. Data written to PORTx is stored and then driven to the corresponding PORTx pins configured as outputs.

Reading PORTx returns the current state of the register regardless of the state of the corresponding pins.

Reading PORTxP returns the current state of the corresponding pins, regardless of whether the pins are input or output.

Every port has a set register (PORTxP/SETx) and a clear register (CLR<sub>x</sub>) for setting or clearing individual bits in PORTx.

In master mode and emulation mode, ports A and B function as the upper external data bus, D[31:16]. When the PCDDPA bit is set, ports C and D function as the lower external data bus, D[15:0]. Ports E–I are configured to support external memory and emulation functions.

In master mode, the function of  $\overline{EB[3:2]}$  is determined by the PCDDPA bit. The function of  $\overline{CS[3:0]}$  is determined by the individual chip select enable (CSEN<sub>x</sub>) bits.

**12.5.1 Pin Functions**
**Table 12-3. Ports A–I Supported Pin Functions**

Pin	Port	Master Mode	Single-Chip Mode	Emulation Mode <sup>(1)</sup>
D[31:24]	A	D[31:24] (I/O)	PA[7:0] (I/O)	D[31:24] (I/O)
D[23:16]	B	D[23:16] (I/O)	PB[7:0](I/O)	D[23:16](I/O)
D[15:8]	C	D[15:8] (I/O) (PCDPA = 1) or PC[7:0] (I/O) (PCDPA = 0)	PC[7:0] (I/O) (PCDPA = 0) <sup>(2)</sup>	D[15:8] (I/O) (PCDPA = 1)
D[7:0]	D	D[7:0] (I/O) (PCDPA = 1) or PD[7:0] (I/O) (PCDPA = 0)	PD[7:0] (I/O) (PCDPA = 0) <sup>(2)</sup>	D[7:0] (I/O) (PCDPA = 1)
$\overline{\text{SHS}}$ <sup>(3)</sup>	E	$\overline{\text{SHS}}$ (O) (PEPAR7 = 1) or PE7 (I/O) (PEPAR7 = 0)	PE7 (I/O) (PEPAR7 = 0) <sup>(4)</sup>	$\overline{\text{SHS}}$ (O) (PEPAR7 = 1)
$\overline{\text{TA}}$		$\overline{\text{TA}}$ (I) (PEPAR6 = 1) or PE6 (I/O) (PEPAR6 = 0)	PE6 (I/O) (PEPAR6 = 0) <sup>(4)</sup>	$\overline{\text{TA}}$ (I) (PEPAR6 = 1)
$\overline{\text{TEA}}$		$\overline{\text{TEA}}$ (I) (PEPAR5 = 1) or PE5 (I/O) (PEPAR5 = 0)	PE5 (I/O) (PEPAR5 = 0) <sup>(4)</sup>	$\overline{\text{TEA}}$ (I) (PEPAR5 = 1)
CSE[1:0]		CSE[1:0] (O) (PEPAR[4:3] = 1) <sup>(5)</sup> or PE[4:3] (I/O) (PEPAR[4:3] = 0)	PE[4:3] (I/O) (PEPAR[4:3] = 0) <sup>(4)</sup>	CSE[1:0] (O) (PEPAR[4:3] = 1)
TC[2:0]		TC[2:0] (O) (PEPAR[2:0] = 1) or PE[2:0] (I/O) (PEPAR[2:0] = 0)	PE[2:0] (I/O) (PEPAR[2:0] = 0) <sup>(4)</sup>	TC[2:0] (O) (PEPAR[2:0] = 1)
R/ $\overline{\text{W}}$		F	R/ $\overline{\text{W}}$ (O)	PF7 (I/O)
A[22:16]	F	A[22:16] (O)	PF[6:0] (I/O)	A[22:16] (O)
A[15:8]	G	A[15:8] (O)	PG[7:0] (I/O)	A[15:8] (O)
A[7:0]	H	A[7:0] (O)	PH[7:0] (I/O)	A[7:0] (O)
$\overline{\text{EB}}[3:2]$	I	$\overline{\text{EB}}[3:2]$ (O) (PCDPA = 1) or PI[7:6] (I/O) (PCDPA = 0)	PI[7:6] (I/O) (PCDPA = 0) <sup>(2)</sup>	$\overline{\text{EB}}[3:2]$ (O) (PCDPA = 1)
$\overline{\text{EB}}[1:0]$		$\overline{\text{EB}}[1:0]$ (O)	PI[5:4] (I/O)	$\overline{\text{EB}}[1:0]$ (O)
$\overline{\text{CS}}[3:0]$		$\overline{\text{CS}}[3:0]$ (O) (CSENx = 1) or PI[3:0] (I/O) (CSENx = 0)	PI[3:0] (I/O) <sup>(6)</sup>	$\overline{\text{CS}}[3:0]$ (O) <sup>(6)</sup>

1. Digital I/O pin function provided by port replacement unit.

2. Writing PCDPA = 1 has an undefined pin operation for D[31:16] and  $\overline{\text{EB}}[3:2]$  in single-chip mode.

3. This pin functions as the reset configuration override enable (RCON) during reset.

4. Writing PEPAX = 1 has an undefined pin operation for port E pins in single-chip mode.

5. Writing PEPAX = 1 has an undefined pin operation for these port E pins in single-chip and master modes.

6. CSENx has no effect on selecting  $\overline{\text{CS}}[3:0]$  pin function in single-chip or emulation modes.

### 12.5.2 Port Digital I/O Timing

Input data on all pins configured as digital I/O is synchronized to the rising edge of CLKOUT. See [Figure 12-8](#).

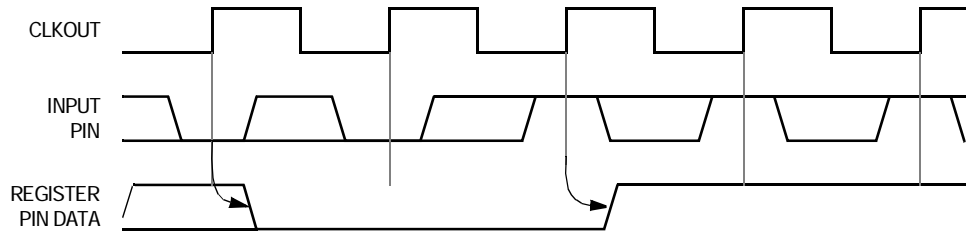

Figure 12-8. Digital Input Timing

Data written to PORTx of any pin configured as a digital output is immediately driven to its respective pin. See [Figure 12-9](#).

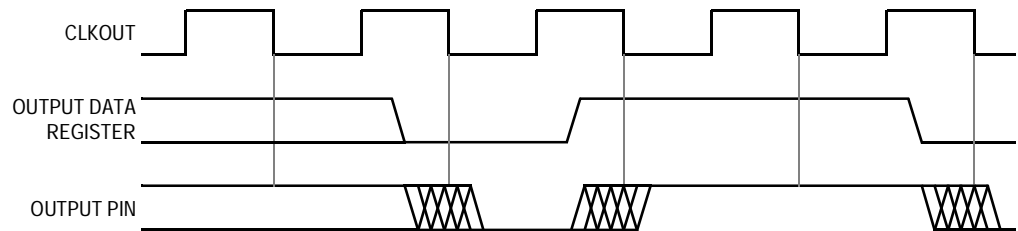

Figure 12-9. Digital Output Timing

### 12.6 Interrupts

The ports module does not generate interrupt requests.



## Section 13. Edge Port Module (EPORT)

### 13.1 Contents

13.2	Introduction	285
13.3	Low-Power Mode Operation	286
13.3.1	Wait and Doze Modes	286
13.3.2	Stop Mode	287
13.4	Interrupt/General-Purpose I/O Pin Descriptions	287
13.5	Memory Map and Registers	287
13.5.1	Memory Map	287
13.5.2	Registers	288
13.5.2.1	EPORT Pin Assignment Register	288
13.5.2.2	EPORT Data Direction Register	290
13.5.2.3	Edge Port Interrupt Enable Register	291
13.5.2.4	Edge Port Data Register	292
13.5.2.5	Edge Port Pin Data Register	292
13.5.2.6	Edge Port Flag Register	293

### 13.2 Introduction

The edge port module (EPORT) has eight external interrupt pins. Each pin can be configured individually as a low level-sensitive interrupt pin, an edge-detecting interrupt pin (rising edge, falling edge, or both), or a general-purpose input/output (I/O) pin. See [Figure 13-1](#).

Edge Port Module (EPORT)

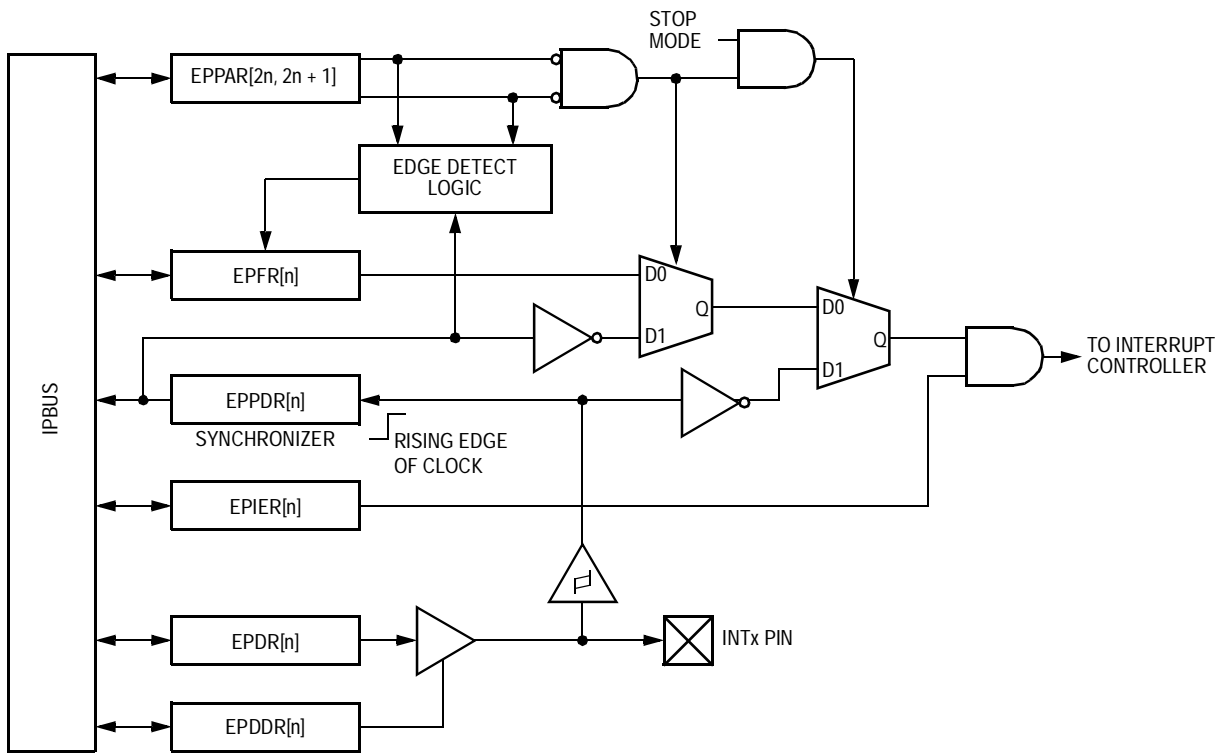

Figure 13-1. EPORT Block Diagram

### 13.3 Low-Power Mode Operation

This subsection describes the operation of the EPORT module in low-power modes.

#### 13.3.1 Wait and Doze Modes

In wait and doze modes, the EPORT module continues to operate normally and may be configured to exit the low-power modes by generating an interrupt request on either a selected edge or a low level on an external pin.

### 13.3.2 Stop Mode

In stop mode, there are no clocks available to perform the edge-detect function. Only the level-detect logic is active (if configured) to allow any low level on the external interrupt pin to generate an interrupt (if enabled) to exit stop mode.

**NOTE:** *The input pin synchronizer is bypassed for the level-detect logic since no clocks are available.*

## 13.4 Interrupt/General-Purpose I/O Pin Descriptions

All pins default to general-purpose input pins at reset. The pin value is synchronized to the rising edge of CLKOUT when read from the EPORT Pin Data Register (EPPDR). The values used in the edge/level detect logic are also synchronized to the rising edge of CLKOUT. These pins use Schmitt triggered input buffers which have built in hysteresis designed to decrease the probability of generating false edge-triggered interrupts for slow rising and falling input signals.

## 13.5 Memory Map and Registers

This subsection describes the memory map and register structure.

### 13.5.1 Memory Map

Refer to [Table 13-1](#) for a description of the EPORT memory map. The EPORT has a base address of 0x00c6\_0000.

**Table 13-1. Edge Port Module Memory Map**

Address	Bits 15–8	Bits 7–0	Access <sup>(1)</sup>
0x00c6_0000	EPORT Pin Assignment Register (EPPAR)		S
0x00c6_0002	EPORT Data Direction Register (EPDDR)	EPORT Interrupt Enable Register (EPIER)	S
0x00c6_0004	EPORT Data Register (EPDR)	EPORT Pin Data Register (EPPDR)	S/U
0x00c6_0006	EPORT Flag Register (EPFR)	Reserved <sup>(2)</sup>	S/U

1. S = CPU supervisor mode access only. S/U = CPU supervisor or user mode access. User mode accesses to supervisor only addresses have no effect and result in a cycle termination transfer error.
2. Writing to reserved address locations has no effect, and reading returns 0s.

### 13.5.2 Registers

The EPORT programming model consists of these registers:

- The EPORT Pin Assignment Register (EPPAR) controls the function of each pin individually.
- The EPORT Data Direction Register (EPDDR) controls the direction of each one of the pins individually.
- The EPORT Interrupt Enable Register (EPIER) enables interrupt requests for each pin individually.
- The EPORT Data Register (EPDR) holds the data to be driven to the pins.
- The EPORT Pin Data Register (EPPDR) reflects the current state of the pins.
- The EPORT Flag Register (EPFR) individually latches EPORT edge events.

#### 13.5.2.1 EPORT Pin Assignment Register

Address: 0x00c6\_0000 and 0x00c6\_0001

	Bit 15	14	13	12	11	10	9	Bit 8
Read:	EPPA7		EPPA6		EPPA5		EPPA4	
Write:	EPPA7		EPPA6		EPPA5		EPPA4	
Reset:	0	0	0	0	0	0	0	0
	Bit 7	6	5	4	3	2	1	Bit 0
Read:	EPPA3		EPPA2		EPPA1		EPPA0	
Write:	EPPA3		EPPA2		EPPA1		EPPA0	
Reset:	0	0	0	0	0	0	0	0

**Figure 13-2. EPORT Pin Assignment Register (EPPAR)**



**EPPA[7:0] — EPORT Pin Assignment Select Fields**

The read/write EPPAx fields configure EPORT pins for level detection and rising and/or falling edge detection as **Table 13-2** shows.

Pins configured as level-sensitive are inverted so that a logic 0 on the external pin represents a valid interrupt request. Level-sensitive interrupt inputs are not latched. To guarantee that a level-sensitive interrupt request is acknowledged, the interrupt source must keep the signal asserted until acknowledged by software. Level sensitivity must be selected to bring the device out of stop mode with an INTx interrupt.

Pins configured as edge-triggered are latched and need not remain asserted for interrupt generation. A pin configured for edge detection is monitored regardless of its configuration as input or output.

**Table 13-2. EPPAx Field Settings**

EPPAx	Pin Configuration
00	Pin INTx level-sensitive
01	Pin INTx rising edge triggered
10	Pin INTx falling edge triggered
11	Pin INTx both falling edge and rising edge triggered

Interrupt requests generated in the EPORT module can be masked by the interrupt controller module. EPPAR functionality is independent of the selected pin direction.

Reset clears the EPPAx fields.

13.5.2.2 EPORT Data Direction Register

Address: 0x00c6\_0002

	Bit 7	6	5	4	3	2	1	Bit 0
Read:	EPDD7	EPDD6	EPDD5	EPDD4	EPDD3	EPDD2	EPDD1	EPDD0
Write:								
Reset:	0	0	0	0	0	0	0	0

**Figure 13-3. EPORT Data Direction Register (EPDDR)**

EPDD[7:0] — Edge Port Data Direction Bits

Setting any bit in the EPDDR configures the corresponding pin as an output. Clearing any bit in EPDDR configures the corresponding pin as an input. Pin direction is independent of the level/edge detection configuration. Reset clears EPDD[7:0].

To use an EPORT pin as an external interrupt request source, its corresponding bit in EPDDR must be clear. Software can generate interrupt requests by programming the EPORT Data Register when the EPDDR selects output.

- 1 = Corresponding EPORT pin configured as output
- 0 = Corresponding EPORT pin configured as input

13.5.2.3 Edge Port Interrupt Enable Register

Address: 0x00c6\_0003

	Bit 7	6	5	4	3	2	1	Bit 0
Read:	EPIE7	EPIE6	EPIE5	EPIE4	EPIE3	EPIE2	EPIE1	EPIE0
Write:	EPIE7	EPIE6	EPIE5	EPIE4	EPIE3	EPIE2	EPIE1	EPIE0
Reset:	0	0	0	0	0	0	0	0

**Figure 13-4. EPORT Port Interrupt Enable Register (EPIER)**

EPIE[7:0] — Edge Port Interrupt Enable Bits

The read/write EPIE[7:0] bits enable EPORT interrupt requests. If a bit in EPIER is set, EPORT generates an interrupt request when:

- The corresponding bit in the EPORT Flag Register (EPFR) is set or later becomes set, or
- The corresponding pin level is low and the pin is configured for level-sensitive operation

Clearing a bit in EPIER negates any interrupt request from the corresponding EPORT pin. Reset clears EPIE[7:0].

- 1 = Interrupt requests from corresponding EPORT pin enabled
- 0 = Interrupt requests from corresponding EPORT pin disabled

Edge Port Module (EPORT)

13.5.2.4 Edge Port Data Register

Address: 0x00c6\_0004

	Bit 7	6	5	4	3	2	1	Bit 0
Read:	EPD7	EPD6	EPD5	EPD4	EPD3	EPD2	EPD1	EPD0
Write:								
Reset:	1	1	1	1	1	1	1	1

Figure 13-5. EPORT Port Data Register (EPDR)

EPD[7:0] — Edge Port Data Bits

Data written to EPDR is stored in an internal register; if any pin of the port is configured as an output, the bit stored for that pin is driven onto the pin. Reading EPDR returns the data stored in the register. Reset sets EPD[7:0].

13.5.2.5 Edge Port Pin Data Register

Address: 0x00c6\_0005

	Bit 7	6	5	4	3	2	1	Bit 0
Read:	EPPD7	EPPD6	EPPD5	EPPD4	EPPD3	EPPD2	EPPD1	EPPD0
Write:								
Reset:	P	P	P	P	P	P	P	P

= Writes have no effect and the access terminates without a transfer error exception.

P = Current pin state

Figure 13-6. EPORT Port Pin Data Register (EPPDR)

EPPD[7:0] — Edge Port Pin Data Bits

The read-only EPPDR reflects the current state of the EPORT pins. Writing to EPPDR has no effect, and the write cycle terminates normally. Reset does not affect EPPDR.

13.5.2.6 Edge Port Flag Register

Address: 0x00c6\_0006

	Bit 7	6	5	4	3	2	1	Bit 0
Read:	EPF7	EPF6	EPF5	EPF4	EPF3	EPF2	EPF1	EPF0
Write:								
Reset:	0	0	0	0	0	0	0	0

**Figure 13-7. EPORT Port Flag Register (EPFR)**

EPF[7:0] — Edge Port Flag Bits

When an EPORT pin is configured for edge triggering, its corresponding read/write bit in EPFR indicates that the selected edge has been detected. Reset clears EPF[7:0].

1 = Selected edge for INTx pin has been detected.

0 = Selected edge for INTx pin has not been detected.

Bits in this register are set when the selected edge is detected on the corresponding pin. A bit remains set until cleared by writing a 1 to it. Writing 0 has no effect. If a pin is configured as level-sensitive (EPPARx = 00), pin transitions do not affect this register.



## Section 14. Watchdog Timer Module

### 14.1 Contents

14.2	Introduction . . . . .	295
14.3	Modes of Operation . . . . .	296
14.3.1	Wait Mode . . . . .	296
14.3.2	Doze Mode . . . . .	296
14.3.3	Stop Mode . . . . .	296
14.3.4	Debug Mode . . . . .	296
14.4	Block Diagram . . . . .	297
14.5	Signals . . . . .	297
14.6	Memory Map and Registers . . . . .	298
14.6.1	Memory Map . . . . .	298
14.6.2	Registers . . . . .	298
14.6.2.1	Watchdog Control Register . . . . .	299
14.6.2.2	Watchdog Modulus Register . . . . .	301
14.6.2.3	Watchdog Count Register . . . . .	302
14.6.2.4	Watchdog Service Register . . . . .	303

### 14.2 Introduction

The watchdog timer is a 16-bit timer used to help software recover from runaway code. The watchdog timer has a free-running down-counter (watchdog counter) that generates a reset on underflow. To prevent a reset, software must periodically restart the countdown by servicing the watchdog.

## 14.3 Modes of Operation

This subsection describes the operation of the watchdog timer in low-power modes and debug mode of operation.

### 14.3.1 Wait Mode

In wait mode with the WAIT bit set in the Watchdog Control Register (WCR), watchdog timer operation stops. In wait mode with the WAIT bit clear, the watchdog timer continues to operate normally.

### 14.3.2 Doze Mode

In doze mode with the DOZE bit set in WCR, watchdog timer module operation stops. In doze mode with the DOZE bit clear, the watchdog timer continues to operate normally.

### 14.3.3 Stop Mode

The watchdog operation stops in stop mode. When stop mode is exited, the watchdog operation continues operation from the state it was in prior to entering stop mode.

### 14.3.4 Debug Mode

In debug mode with the DBG bit set in WCR, watchdog timer module operation stops. In debug mode with the DBG bit clear, the watchdog timer continues to operate normally. When debug mode is exited, watchdog timer operation continues from the state it was in before entering debug mode, but any updates made in debug mode remain.



### 14.4 Block Diagram

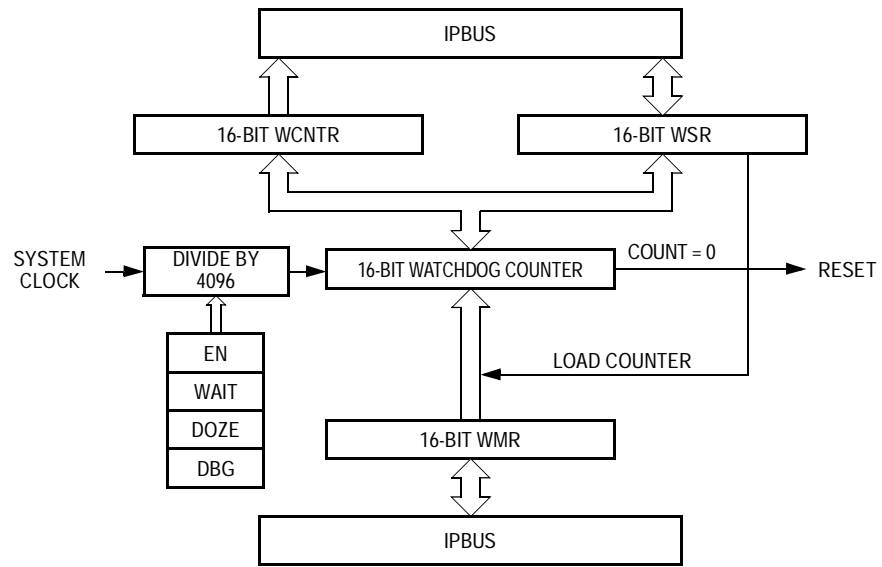

Figure 14-1. Watchdog Timer Block Diagram

### 14.5 Signals

The watchdog timer module has no off-chip signals.

## 14.6 Memory Map and Registers

This subsection describes the memory map and registers for the watchdog timer. The watchdog timer has a base address of 0x00c7\_0000.

### 14.6.1 Memory Map

Refer to [Table 14-1](#) for an overview of the watchdog memory map.

**Table 14-1. Watchdog Timer Module Memory Map**

Address	Bits 15–8	Bits 7–0	Access <sup>(1)</sup>
0x00c7_0000	Watchdog Control Register (WCR)		S
0x00c7_0002	Watchdog Modulus Register (WMR)		S
0x00c7_0004	Watchdog Count Register (WCNTR)		S/U
0x00c7_0006	Watchdog Service Register (WSR)		S/U

1. S = CPU supervisor mode access only. S/U = CPU supervisor or user mode access. User mode accesses to supervisor only addresses have no effect and result in a cycle termination transfer error.

### 14.6.2 Registers

The watchdog timer programming model consists of these registers:

- The Watchdog Control Register (WCR) configures watchdog timer operation. See [14.6.2.1 Watchdog Control Register](#).
- The Watchdog Modulus Register (WMR) determines the timer modulus reload value. See [14.6.2.2 Watchdog Modulus Register](#).
- The Watchdog Count Register (WCNTR) provides visibility to the watchdog counter value. See [14.6.2.3 Watchdog Count Register](#).
- The Watchdog Service Register (WSR) requires a service sequence to prevent reset. See [14.6.2.4 Watchdog Service Register](#).

14.6.2.1 Watchdog Control Register

The 16-bit read/write Watchdog Control Register (WCR) configures watchdog timer operation.

Address: 0x00c7\_0000 and 0x00c7\_0001

	Bit 15	14	13	12	11	10	9	Bit 8
Read:	0	0	0	0	0	0	0	0
Write:								
Reset:	0	0	0	0	0	0	0	0
	Bit 7	6	5	4	3	2	1	Bit 0
Read:	0	0	0	0	WAIT	DOZE	DBG	EN
Write:								
Reset:	0	0	0	0	1	1	1	1

= Writes have no effect and the access terminates without a transfer error exception.

**Figure 14-2. Watchdog Control Register (WCR)**

**WAIT — Wait Mode Bit**

The read-always, write-once WAIT bit controls the function of the watchdog timer in wait mode. Once written, the WAIT bit is not affected by further writes except in debug mode. Reset sets WAIT.

- 1 = Watchdog timer stopped in wait mode
- 0 = Watchdog timer not affected in wait mode

**DOZE — Doze Mode Bit**

The read-always, write-once DOZE bit controls the function of the watchdog timer in doze mode. Once written, the DOZE bit is not affected by further writes except in debug mode. Reset sets DOZE.

- 1 = Watchdog timer stopped in doze mode
- 0 = Watchdog timer not affected in doze mode

**DBG — Debug Mode Bit**

The read-always, write-once DBG bit controls the function of the watchdog timer in debug mode. Once written, the DBG bit is not affected by further writes except in debug mode.

During debug mode, watchdog timer registers can be written and read normally. When debug mode is exited, timer operation continues from the state it was in before entering debug mode, but any updates made in debug mode remain. If a write-once register is written for the first time in debug mode, the register is still writable when debug mode is exited.

1 = Watchdog timer stopped in debug mode

0 = Watchdog timer not affected in debug mode

**NOTE:** *Changing the DBG bit from 1 to 0 during debug mode starts the watchdog timer. Changing the DBG bit from 0 to 1 during debug mode stops the watchdog timer.*

**EN — Watchdog Enable Bit**

The read-always, write-once EN bit enables the watchdog timer. Once written, the EN bit is not affected by further writes except in debug mode. When the watchdog timer is disabled, the watchdog counter and prescaler counter are held in a stopped state.

1 = Watchdog timer enabled

0 = Watchdog timer disabled

14.6.2.2 Watchdog Modulus Register

Address: 0x00c7\_0002 and 0x00c7\_0003

	Bit 15	14	13	12	11	10	9	Bit 8
Read:	WM15	WM14	WM13	WM12	WM11	WM10	WM9	WM8
Write:								
Reset:	1	1	1	1	1	1	1	1
	Bit 7	6	5	4	3	2	1	Bit 0
Read:	WM7	WM6	WM5	WM4	WM3	WM2	WM1	WM0
Write:								
Reset:	1	1	1	1	1	1	1	1

**Figure 14-3. Watchdog Modulus Register (WMR)**

WM[15:0] — Watchdog Modulus Field

The read-always, write-once WM[15:0] field contains the modulus that is reloaded into the watchdog counter by a service sequence. Once written, the WM[15:0] field is not affected by further writes except in debug mode. Writing to WMR immediately loads the new modulus value into the watchdog counter. The new value is also used at the next and all subsequent reloads. Reading WMR returns the value in the modulus register.

Reset initializes the WM[15:0] field to 0xFFFF.

**NOTE:** *The prescaler counter is reset anytime a new value is loaded into the watchdog counter and also during reset.*

**Watchdog Timer Module**

14.6.2.3 Watchdog Count Register

Address: 0x00c7\_0004 and 0x00c7\_0005

	Bit 15	14	13	12	11	10	9	Bit 8
Read:	WC15	WC14	WC13	WC12	WC11	WC10	WC9	WC8
Write:								
Reset:	1	1	1	1	1	1	1	1
	Bit 7	6	5	4	3	2	1	Bit 0
Read:	WC7	WC6	WC5	WC4	WC3	WC2	WC1	WC0
Write:								
Reset:	1	1	1	1	1	1	1	1

 = Writes have no effect and the access terminates without a transfer error exception.

**Figure 14-4. Watchdog Count Register (WCNTR)**

WC[15:0] — Watchdog Count Field

The read-only WC[15:0] field reflects the current value in the watchdog counter. Reading the 16-bit WCNTR with two 8-bit reads is not guaranteed to return a coherent value. Writing to WCNTR has no effect, and write cycles are terminated normally.

14.6.2.4 Watchdog Service Register

When the watchdog timer is enabled, writing 0x5555 and then 0xAAAA to the Watchdog Service Register (WSR) before the watchdog counter times out prevents a reset. If WSR is not serviced before the timeout, the watchdog timer sends a signal to the reset controller module which sets the WDR bit and asserts a system reset.

Both writes must occur in the order listed before the timeout, but any number of instructions can be executed between the two writes. However, writing any value other than 0x5555 or 0xAAAA to WSR resets the servicing sequence, requiring both values to be written to keep the watchdog timer from causing a reset.

Address: 0x00c7\_0006 and 0x00c7\_0007

	Bit 15	14	13	12	11	10	9	Bit 8
Read:	WS15	WS14	WS13	WS12	WS11	WS10	WS9	WS8
Write:								
Reset:	0	0	0	0	0	0	0	0
	Bit 7	6	5	4	3	2	1	Bit 0
Read:	WS7	WS6	WS5	WS4	WS3	WS2	WS1	WS0
Write:								
Reset:	0	0	0	0	0	0	0	0

**Figure 14-5. Watchdog Service Register (WSR)**





## **Section 15. Programmable Interrupt Timer Modules (PIT1 and PIT2)**

### **15.1 Contents**

15.2	Introduction .....	306
15.3	Block Diagram .....	306
15.4	Modes of Operation .....	307
15.4.1	Wait Mode .....	307
15.4.2	Doze Mode .....	307
15.4.3	Stop Mode .....	307
15.4.4	Debug Mode .....	307
15.5	Signals .....	307
15.6	Memory Map and Registers .....	308
15.6.1	Memory Map .....	308
15.6.2	Registers .....	308
15.6.2.1	PIT Control and Status Register .....	309
15.6.2.2	PIT Modulus Register .....	312
15.6.2.3	PIT Count Register .....	313
15.7	Functional Description .....	314
15.7.1	Set-and-Forget Timer Operation .....	314
15.7.2	Free-Running Timer Operation .....	315
15.7.3	Timeout Specifications .....	315
15.8	Interrupt Operation .....	316

### 15.2 Introduction

The programmable interrupt timer (PIT) is a 16-bit timer that provides precise interrupts at regular intervals with minimal processor intervention. The timer can either count down from the value written in the modulus latch, or it can be a free-running down-counter.

This device has two programmable interrupt timers. PIT1 has a base address located at 0x00c8\_0000. PIT2 base address is 0x00c9\_0000.

### 15.3 Block Diagram

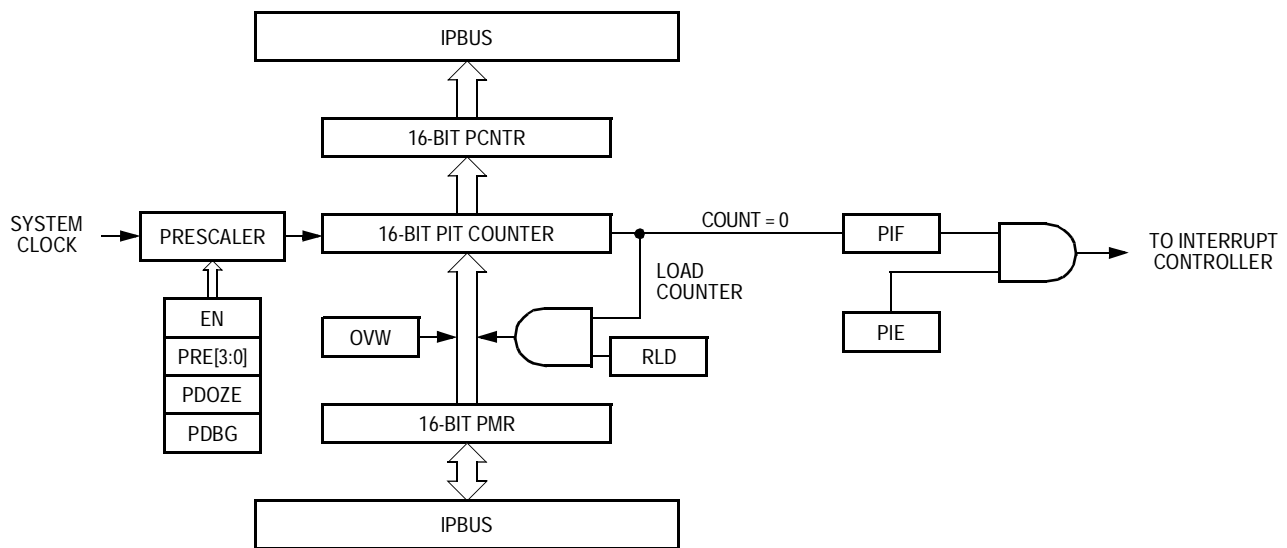

Figure 15-1. PIT Block Diagram

## 15.4 Modes of Operation

This subsection describes the three low-power modes and the debug mode.

### 15.4.1 Wait Mode

In wait mode, the PIT module continues to operate normally and can be configured to exit the low-power mode by generating an interrupt request.

### 15.4.2 Doze Mode

In doze mode with the PDOZE bit set in the PIT Control and Status Register (PCSR), PIT module operation stops. In doze mode with the PDOZE bit clear, doze mode does not affect PIT operation. When doze mode is exited, PIT operation continues from the state it was in before entering doze mode.

### 15.4.3 Stop Mode

In stop mode, the system clock is absent, and PIT module operation stops.

### 15.4.4 Debug Mode

In debug mode with the PDBG bit set in PCSR, PIT module operation stops. In debug mode with the PDBG bit clear, debug mode does not affect PIT operation. When debug mode is exited, PIT operation continues from the state it was in before entering debug mode, but any updates made in debug mode remain.

## 15.5 Signals

The PIT module has no off-chip signals.

**Programmable Interrupt Timer Modules (PIT1 and PIT2)**

**15.6 Memory Map and Registers**

This subsection describes the memory map and register structure for PIT1 and PIT2.

**15.6.1 Memory Map**

Refer to [Table 15-1](#) for a description of the memory map.

This device has two programmable interrupt timers. PIT1 has a base address located at 0x00c8\_0000. PIT2 base address is 0x00c9\_0000.

**Table 15-1. Programmable Interrupt Timer Modules Memory Map**

PIT1 Address	PIT2 Address	Bits 15–8	Bits 7–0	Access <sup>(1)</sup>
0x00c8_0000	0x00c9_0000	PIT Control and Status Register (PCSR)		S
0x00c8_0002	0x00c9_0002	PIT Modulus Register (PMR)		S
0x00c8_0004	0x00c9_0004	PIT Count Register (PCNTR)		S/U
0x00c8_0006	0x00c9_0006	Unimplemented <sup>(2)</sup>		—

1. S = CPU supervisor mode access only. S/U = CPU supervisor or user mode access. User mode accesses to supervisor only addresses have no effect and result in a cycle termination transfer error.  
 2. Accesses to unimplemented address locations have no effect and result in a cycle termination transfer error.

**15.6.2 Registers**

The PIT programming model consists of these registers:

- The PIT Control and Status Register (PCSR) configures the timer’s operation. See [15.6.2.1 PIT Control and Status Register](#).
- The PIT Modulus Register (PMR) determines the timer modulus reload value. See [15.6.2.2 PIT Modulus Register](#).
- The PIT Count Register (PCNTR) provides visibility to the counter value. See [15.6.2.3 PIT Count Register](#).

## 15.6.2.1 PIT Control and Status Register

Address: PIT1 — 0x00c8\_0000 and 0x00c8\_0001  
PIT2 — 0x00c9\_0000 and 0x00c9\_0001

	Bit 15	14	13	12	11	10	9	Bit 8
Read:	0	0	0	0	PRE3	PRE2	PRE1	PRE0
Write:								
Reset:	0	0	0	0	0	0	0	0
	Bit 7	6	5	4	3	2	1	Bit 0
Read:	0	PDOZE	PDBG	OVW	PIE	PIF	RLD	EN
Write:								
Reset:	0	0	0	0	0	0	0	0

= Writes have no effect and the access terminates without a transfer error exception.

**Figure 15-2. PIT Control and Status Register (PCSR)**

### PRE[3:0] — Prescaler Bits

The read/write PRE[3:0] bits select the system clock divisor to generate the PIT clock as [Table 15-2](#) shows.

To accurately predict the timing of the next count, change the PRE[3:0] bits only when the enable bit (EN) is clear. Changing the PRE[3:0] resets the prescaler counter. System reset and the loading of a new value into the counter also reset the prescaler counter. Setting the EN bit and writing to PRE[3:0] can be done in this same write cycle. Clearing the EN bit stops the prescaler counter.

### PDOZE — Doze Mode Bit

The read/write PDOZE bit controls the function of the PIT in doze mode. Reset clears PDOZE.

- 1 = PIT function stopped in doze mode
- 0 = PIT function not affected in doze mode

When doze mode is exited, timer operation continues from the state it was in before entering doze mode.

Table 15-2. Prescaler Select Encoding

PRE[3:0]	System Clock Divisor
0000	1
0001	2
0010	4
0011	8
0100	16
0101	32
0110	64
0111	128
1000	256
1001	512
1010	1,024
1011	2,048
1100	4,096
1101	8,192
1110	16,384
1111	32,768

PDBG — Debug Mode Bit

The read/write PDBG bit controls the function of the PIT in debug mode. Reset clears PDBG.

1 = PIT function stopped in debug mode

0 = PIT function not affected in debug mode

During debug mode, register read and write accesses function normally. When debug mode is exited, timer operation continues from the state it was in before entering debug mode, but any updates made in debug mode remain.

**NOTE:** *Changing the PDBG bit from 1 to 0 during debug mode starts the PIT timer. Likewise, changing the PDBG bit from 0 to 1 during debug mode stops the PIT timer.*

**OVW — Overwrite Bit**

The read/write OVW bit enables writing to PMR to immediately overwrite the value in the PIT counter.

- 1 = Writing PMR immediately replaces value in PIT counter.
- 0 = Value in PMR replaces value in PIT counter when count reaches 0x0000.

**PIE — PIT Interrupt Enable Bit**

The read/write PIE bit enables the PIF flag to generate interrupt requests.

- 1 = PIF interrupt requests enabled
- 0 = PIF interrupt requests disabled

**PIF — PIT Interrupt Flag**

The read/write PIF flag is set when the PIT counter reaches 0x0000. Clear PIF by writing a 1 to it or by writing to PMR. Writing 0 has no effect. Reset clears PIF.

- 1 = PIT count has reached 0x0000.
- 0 = PIT count has not reached 0x0000.

**RLD — Reload Bit**

The read/write RLD bit enables loading the value of PMR into the PIT counter when the count reaches 0x0000.

- 1 = Counter reloaded from PMR on count of 0x0000
- 0 = Counter rolls over to 0xFFFF on count of 0x0000

**EN — PIT Enable Bit**

The read/write EN bit enables PIT operation. When the PIT is disabled, the counter and prescaler are held in a stopped state.

- 1 = PIT enabled
- 0 = PIT disabled

**Programmable Interrupt Timer Modules (PIT1 and PIT2)**

15.6.2.2 PIT Modulus Register

The 16-bit read/write PIT Modulus Register (PMR) contains the timer modulus value for loading into the PIT counter when the count reaches 0x0000 and the RLD bit is set.

When the OVW bit is set, PMR is transparent, and the value written to PMR is immediately loaded into the PIT counter. The prescaler counter is reset anytime a new value is loaded into the PIT counter and also during reset. Reading the PMR returns the value written in the modulus latch. Reset initializes PMR to 0xFFFF.

Address: PIT1 — 0x00c8\_0002 and 0x00c8\_0003  
 PIT2 — 0x00c9\_0002 and 0x00c9\_0003

	Bit 15	14	13	12	11	10	9	Bit 8
Read:	PM15	PM14	PM13	PM12	PM11	PM10	PM9	PM8
Write:								
Reset:	1	1	1	1	1	1	1	1
	Bit 7	6	5	4	3	2	1	Bit 0
Read:	PM7	PM6	PM5	PM4	PM3	PM2	PM1	PM0
Write:								
Reset:	1	1	1	1	1	1	1	1

**Figure 15-3. PIT Modulus Register (PMR)**



15.6.2.3 PIT Count Register

The 16-bit, read-only PIT Control Register (PCNTR) contains the counter value. Reading the 16-bit counter with two 8-bit reads is not guaranteed to be coherent. Writing to PCNTR has no effect, and write cycles are terminated normally.

Address: PIT1 — 0x00c8\_0004 and 0x00c8\_0005  
PIT2 — 0x00c9\_0004 and 0x00c9\_0005

	Bit 15	14	13	12	11	10	9	Bit 8
Read:	PC15	PC14	PC13	PC12	PC11	PC10	PC9	PC8
Write:								
Reset:	1	1	1	1	1	1	1	1
	Bit 7	6	5	4	3	2	1	Bit 0
Read:	PC7	PC6	PC5	PC4	PC3	PC2	PC1	PC0
Write:								
Reset:	1	1	1	1	1	1	1	1

= Writes have no effect and the access terminates without a transfer error exception.

**Figure 15-4. PIT Count Register (PCNTR)**

## 15.7 Functional Description

This subsection describes the PIT functional operation.

### 15.7.1 Set-and-Forget Timer Operation

This mode of operation is selected when the RLD bit in the PCSR register is set.

When the PIT counter reaches a count of 0x0000, the PIF flag is set in PCSR. The value in the modulus latch is loaded into the counter, and the counter begins decrementing toward 0x0000. If the PIE bit is set in PCSR, the PIF flag issues an interrupt request to the CPU.

When the OVW bit is set in PCSR, the counter can be directly initialized by writing to PMR without having to wait for the count to reach 0x0000.

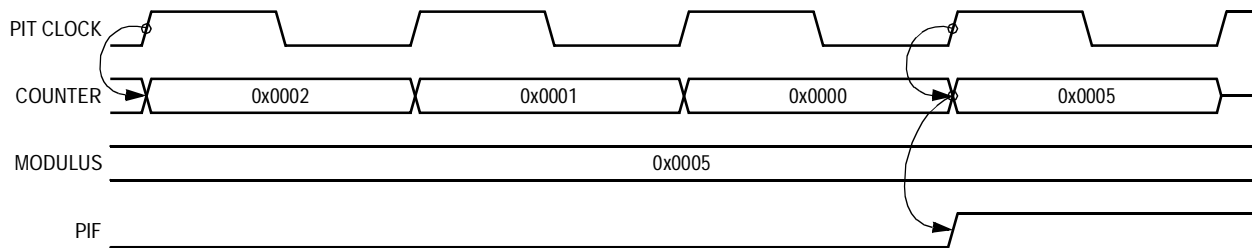

Figure 15-5. Counter Reloading from the Modulus Latch

### 15.7.2 Free-Running Timer Operation

This mode of operation is selected when the RLD bit in PCSR is clear. In this mode, the counter rolls over from 0x0000 to 0xFFFF without reloading from the modulus latch and continues to decrement.

When the counter reaches a count of 0x0000, the PIF flag is set in PCSR. If the PIE bit is set in PCSR, the PIF flag issues an interrupt request to the CPU.

When the OVW bit is set in PCSR, the counter can be directly initialized by writing to PMR without having to wait for the count to reach 0x0000.

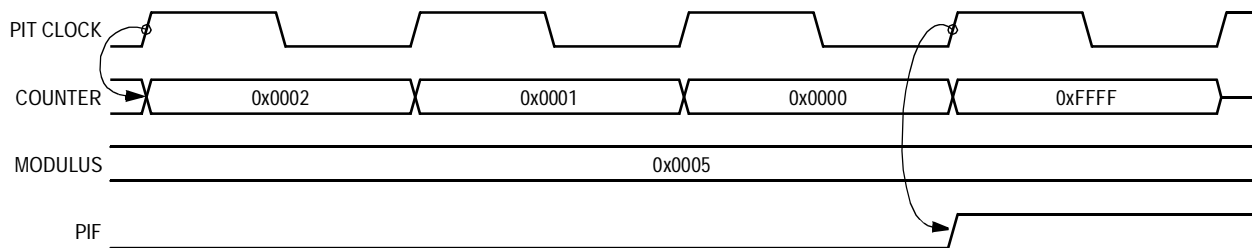

**Figure 15-6. Counter in Free-Running Mode**

### 15.7.3 Timeout Specifications

The 16-bit PIT counter and prescaler supports different timeout periods. The prescaler divides the system clock as selected by the PRE[3:0] bits in PCSR. The PM[15:0] bits in PMR select the timeout period.

$$\text{timeout period} = \text{PRE}[3:0] \times (\text{PM}[15:0] + 1) \text{ clocks}$$

## 15.8 Interrupt Operation

**Table 15-3** lists the interrupt requests generated by the PIT.

**Table 15-3. PIT Interrupt Requests**

Interrupt Request	Flag	Enable Bit
Timeout	PIF	PIE

The PIF flag is set when the PIT counter reaches 0x0000. The PIE bit enables the PIF flag to generate interrupt requests. Clear PIF by writing a 1 to it or by writing to the PMR.

## Section 16. Timer Modules (TIM1 and TIM2)

### 16.1 Contents

16.2	Introduction .....	319
16.3	Features .....	319
16.4	Block Diagram .....	320
16.5	Modes of Operation .....	321
16.5.1	Supervisor and User Modes .....	321
16.5.2	Run Mode .....	321
16.5.3	Stop Mode .....	321
16.5.4	Wait, Doze, and Debug Modes .....	321
16.5.5	Test Mode .....	322
16.6	Signal Description .....	322
16.6.1	ICOC[2:0] .....	322
16.6.2	ICOC3 .....	322
16.7	Memory Map and Registers .....	323
16.7.1	Timer Input Capture/Output Compare Select Register ..	324
16.7.2	Timer Compare Force Register .....	325
16.7.3	Timer Output Compare 3 Mask Register .....	326
16.7.4	Timer Output Compare 3 Data Register .....	327
16.7.5	Timer Counter Registers .....	328
16.7.6	Timer System Control Register 1 .....	329
16.7.7	Timer Toggle-On-Overflow Register .....	330
16.7.8	Timer Control Register 1 .....	331
16.7.9	Timer Control Register 2 .....	332
16.7.10	Timer Interrupt Enable Register .....	333
16.7.11	Timer System Control Register 2 .....	334
16.7.12	Timer Flag Register 1 .....	336
16.7.13	Timer Flag Register 2 .....	337
16.7.14	Timer Channel Registers .....	338

**Timer Modules (TIM1 and TIM2)**

- 16.7.15 Pulse Accumulator Control Register ..... 339
- 16.7.16 Pulse Accumulator Flag Register ..... 341
- 16.7.17 Pulse Accumulator Counter Registers ..... 342
- 16.7.18 Timer Port Data Register ..... 343
- 16.7.19 Timer Port Data Direction Register ..... 344
- 16.7.20 Timer Test Register ..... 345
  
- 16.8 Functional Description ..... 345
  - 16.8.1 Prescaler ..... 345
  - 16.8.2 Input Capture ..... 345
  - 16.8.3 Output Compare ..... 346
  - 16.8.4 Pulse Accumulator ..... 347
    - 16.8.4.1 Event Counter Mode ..... 347
    - 16.8.4.2 Gated Time Accumulation Mode ..... 348
  - 16.8.5 General-Purpose I/O Ports ..... 349
  
- 16.9 Reset ..... 351
  
- 16.10 Interrupts ..... 351
  - 16.10.1 Timer Channel Interrupts (CxI) ..... 351
  - 16.10.2 Pulse Accumulator Overflow (PAOVF) ..... 352
  - 16.10.3 Pulse Accumulator Input (PAIF) ..... 352
  - 16.10.4 Timer Overflow (TOF) ..... 352

## 16.2 Introduction

The MMC2114, MMC2113 and MMC2112 have two 4-channel timer modules (TIM1 and TIM2). Each consists of a 16-bit programmable counter driven by a 7-stage programmable prescaler. Each of the four timer channels can be configured for input capture or output compare. Additionally, one of the channels, channel 3, can be configured as a pulse accumulator.

A timer overflow function allows software to extend the timing capability of the system beyond the 16-bit range of the counter. The input capture and output compare functions allow simultaneous input waveform measurements and output waveform generation. The input capture function can capture the time of a selected transition edge. The output compare function can generate output waveforms and timer software delays. The 16-bit pulse accumulator can operate as a simple event counter or a gated time accumulator. The pulse accumulator shares timer channel 3 when in event mode.

## 16.3 Features

Features of the timer include:

- Four 16-bit input capture/output compare channels
- 16-bit architecture
- Programmable prescaler
- Pulse widths variable from microseconds to seconds
- Single 16-bit pulse accumulator
- Toggle-on-overflow feature for pulse-width modulator (PWM) generation

Timer Modules (TIM1 and TIM2)

16.4 Block Diagram

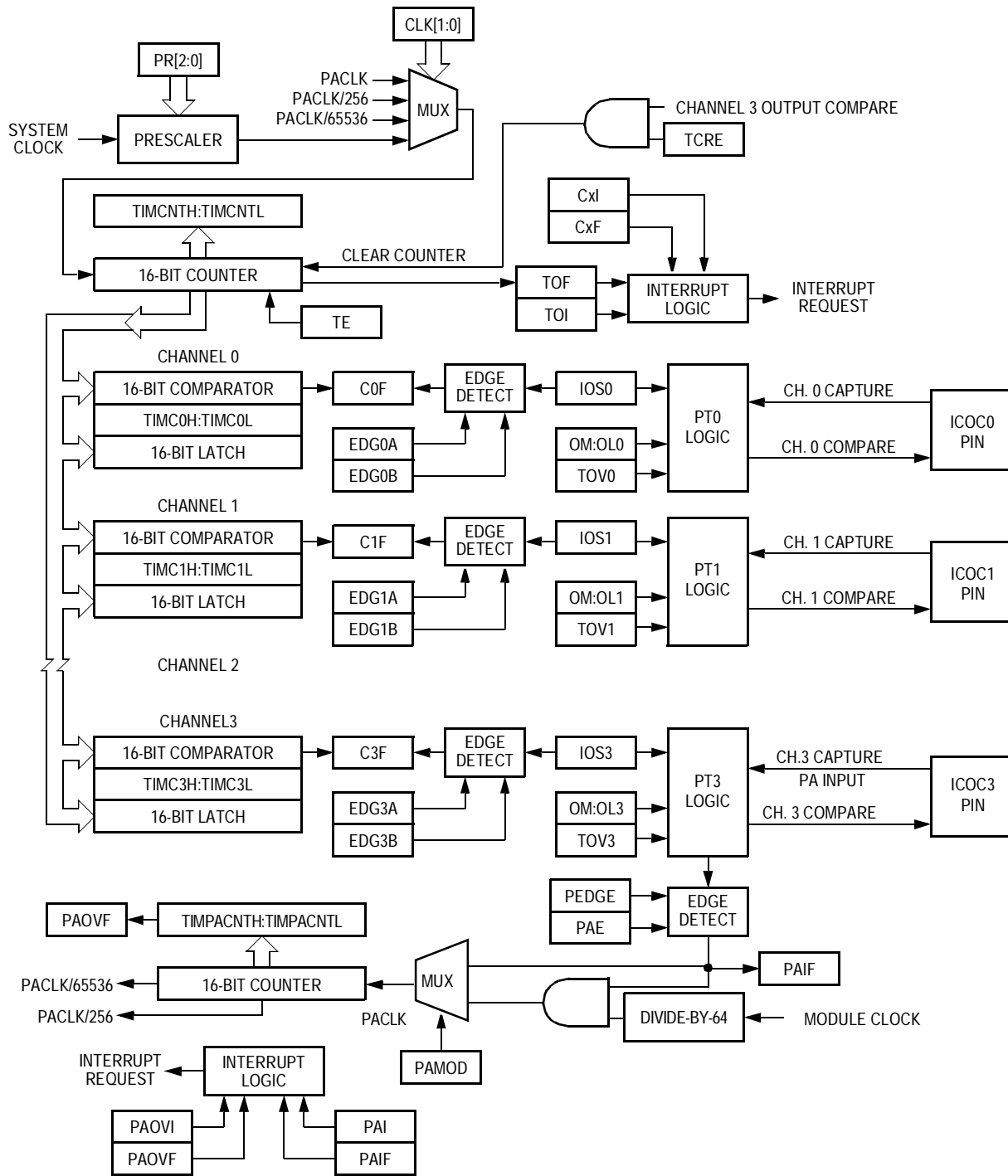

Figure 16-1. Timer Block Diagram



## 16.5 Modes of Operation

This subsection describes the supervisor and user modes, the five low-power options, and test mode.

### 16.5.1 Supervisor and User Modes

The SO bit in the Chip-Select Control Register determines whether the processor is operating in user mode or supervisor mode. Accessing supervisor address locations while not in supervisor mode causes the timer to assert a transfer error. See [Figure 21-2. Chip Select Control Register 0 \(CSCR0\)](#).

### 16.5.2 Run Mode

Clearing the TIMEN bit in the Timer System Control Register 1 (TIMSCR1) or the PAE bit in the Pulse Accumulator Control Register (TIMPACTL) reduces power consumption in run mode. Timer registers are still accessible, but all timer functions are disabled. See [Figure 16-8. Timer System Control Register \(TIMSCR1\)](#) and [Figure 16-19. Pulse Accumulator Control Register \(TIMPACTL\)](#).

### 16.5.3 Stop Mode

If the central processor unit (CPU) enters stop mode, timer operation stops. Upon exiting stop mode, the timer resumes operation unless stop mode was exited by reset.

### 16.5.4 Wait, Doze, and Debug Modes

The timer is unaffected by these low-power modes.

**Timer Modules (TIM1 and TIM2)**

**16.5.5 Test Mode**

A high signal on the TEST pin puts the processor in test mode or special mode. The timer behaves as in user mode, except that timer test registers are accessible.

**16.6 Signal Description**

**Table 16-1** provides an overview of the signal properties.

**Table 16-1. Signal Properties**

Pin Name <sup>(1)</sup>	TIMPORT Register Bit	Function	Reset State	Pullup
ICOCx0	PORTT0	Timer x channel 0 IC/OC pin	Pin state	Active
ICOCx1	PORTT1	Timer x channel 1 IC/OC pin	Pin state	Active
ICOCx2	PORTT2	Timer x channel 2 IC/OC pin	Pin state	Active
ICOCx3	PORTT3	Timer x channel 3 IC/OC or PA pin	Pin state	Active

1. x is timer designation 1 or 2

**16.6.1 ICOC[2:0]**

The ICOC[2:0] pins are for channel 2–0 input capture and output compare functions. These pins are available for general-purpose input/output (I/O) when not configured for timer functions.

**16.6.2 ICOC3**

The ICOC3 pin is for channel 3 input capture and output compare functions or for the pulse accumulator input. This pin is available for general-purpose I/O when not configured for timer functions.

## 16.7 Memory Map and Registers

See [Table 16-2](#) for a memory map of the two timer modules. Timer 1 has a base address of 0x00ce\_0000. Timer 2 has a base address of 0x00cf\_0000.

**NOTE:** Reading reserved or unimplemented locations returns 0s. Writing to reserved or unimplemented locations has no effect.

**Table 16-2. Timer Modules Memory Map**

Address		Bits 7–0	Access <sup>(1)</sup>
TIM1	TIM2		
0x00ce_0000	0x00cf_0000	Timer IC/OC Select Register (TIMIOS)	S
0x00ce_0001	0x00cf_0001	Timer Compare Force Register (TIMCFORC)	S
0x00ce_0002	0x00cf_0002	Timer Output Compare 3 Mask Register (TIMOC3M)	S
0x00ce_0003	0x00cf_0003	Timer Output Compare 3 Data Register (TIMOC3D)	S
0x00ce_0004	0x00cf_0004	Timer Counter Register High (TIMCNTH)	S
0x00ce_0005	0x00cf_0005	Timer Counter Register Low (TIMCNTL)	S
0x00ce_0006	0x00cf_0006	Timer System Control Register 1 (TIMSCR1)	S
0x00ce_0007	0x00cf_0007	Reserved <sup>(2)</sup>	—
0x00ce_0008	0x00cf_0008	Timer Toggle-on-Overflow Register (TMTOV)	S
0x00ce_0009	0x00cf_0009	Timer Control Register 1 (TIMCTL1)	S
0x00ce_000a	0x00cf_000a	Reserved <sup>(2)</sup>	—
0x00ce_000b	0x00cf_000b	Timer Control Register 2 (TIMCTL2)	S
0x00ce_000c	0x00cf_000c	Timer Interrupt Enable Register (TIMIE)	S
0x00ce_000d	0x00cf_000d	Timer System Control Register 2 (TIMSCR2)	S
0x00ce_000e	0x00cf_000e	Timer Flag Register 1 (TIMFLG1)	S
0x00ce_000f	0x00cf_000f	Timer Flag Register 2 (TIMFLG2)	S
0x00ce_0010	0x00cf_0010	Timer Channel 0 Register High (TIMC0H)	S
0x00ce_0011	0x00cf_0011	Timer Channel 0 Register Low (TIMC0L)	S
0x00ce_0012	0x00cf_0012	Timer Channel 1 Register High (TIMC1H)	S
0x00ce_0013	0x00cf_0013	Timer Channel 1 Register Low (TIMC1L)	S
0x00ce_0014	0x00cf_0014	Timer Channel 2 Register High (TIMC2H)	S
0x00ce_0015	0x00cf_0015	Timer Channel 2 Register Low (TIMC2L)	S
0x00ce_0016	0x00cf_0016	Timer Channel 3 Register High (TIMC3H)	S

Table 16-2. Timer Modules Memory Map (Continued)

Address		Bits 7–0	Access <sup>(1)</sup>
TIM1	TIM2		
0x00ce_0017	0x00cf_0017	Timer Channel 3 Register Low (TIMC3L)	S
0x00ce_0018	0x00cf_0018	Pulse Accumulator Control Register (TIMPACTL)	S
0x00ce_0019	0x00cf_0019	Pulse Accumulator Flag Register (TIMPAFLG)	S
0x00ce_001a	0x00cf_001a	Pulse Accumulator Counter Register High (TIMPACNTH)	S
0x00ce_001b	0x00cf_001b	Pulse Accumulator Counter Register Low (TIMPACNTL)	S
0x00ce_001c	0x00cf_001c	Reserved <sup>(2)</sup>	—
0x00ce_001d	0x00cf_001d	Timer Port Data Register (TIMPORT)	S
0x00ce_001e	0x00cf_001e	Timer Port Data Direction Register (TIMDDR)	S
0x00ce_001f	0x00cf_001f	Timer Test Register (TIMTST)	S

1. S = CPU supervisor mode access only.
2. Writes have no effect, reads return 0s, and the access terminates without a transfer error exception.

### 16.7.1 Timer Input Capture/Output Compare Select Register

Address: TIM1 — 0x00ce\_0000  
 TIM2 — 0x00cf\_0000

	Bit 7	6	5	4	3	2	1	Bit 0
Read:	0	0	0	0	IOS3	IOS2	IOS1	IOS0
Write:					IOS3	IOS2	IOS1	IOS0
Reset:	0	0	0	0	0	0	0	0

= Writes have no effect and the access terminates without a transfer error exception.

Figure 16-2. Timer Input Capture/Output Compare Select Register (TIMIOS)

Read: Anytime; always read \$00

Write: Anytime

IOS[3:0] — I/O Select Bits

The IOS[3:0] bits enable input capture or output compare operation for the corresponding timer channels.

- 1 = Output compare enabled
- 0 = Input capture enabled

**16.7.2 Timer Compare Force Register**

Address: TIM1 — 0x00ce\_0001  
TIM2 — 0x00cf\_0001

	Bit 7	6	5	4	3	2	1	Bit 0
Read:	0	0	0	0	0	0	0	0
Write:					FOC3	FOC2	FOC1	FOC0
Reset:	0	0	0	0	0	0	0	0

= Writes have no effect and the access terminates without a transfer error exception.

**Figure 16-3. Timer Compare Force Register (TIMCFORC)**

Read: Anytime

Write: Anytime

FOC[3:0] — Force Output Compare Bits

Setting an FOC bit causes an immediate output compare on the corresponding channel. Forcing an output compare does not set the output compare flag.

- 1 = Force output compare
- 0 = No effect

**NOTE:** *A successful channel 3 output compare overrides any channel 2:0 compares. For each OC3M bit that is set, the output compare action reflects the corresponding OC3D bit.*

Timer Modules (TIM1 and TIM2)

16.7.3 Timer Output Compare 3 Mask Register

Address: TIM1 — 0x00ce\_0002  
 TIM2 — 0x00cf\_0002

	Bit 7	6	5	4	3	2	1	Bit 0
Read:	0	0	0	0	OC3M3	OC3M2	OC3M1	OC3M0
Write:								
Reset:	0	0	0	0	0	0	0	0

= Writes have no effect and the access terminates without a transfer error exception.

**Figure 16-4. Timer Output Compare 3 Mask Register (TIMOC3M)**

Read: Anytime

Write: Anytime

OC3M[3:0] — Output Compare 3 Mask Bits

Setting an OC3M bit configures the corresponding TIMPORT pin to be an output. OC3Mx makes the timer port pin an output regardless of the data direction bit when the pin is configured for output compare (IOSx = 1). The OC3Mx bits do not change the state of the TIMDDR bits.

- 1 = Corresponding TIMPORT pin configured as output
- 0 = No effect

### 16.7.4 Timer Output Compare 3 Data Register

Address: TIM1 — 0x00ce\_0003  
TIM2 — 0x00cf\_0003

	Bit 7	6	5	4	3	2	1	Bit 0
Read:	0	0	0	0	OC3D3	OC3D2	OC3D1	OC3D0
Write:					OC3D3	OC3D2	OC3D1	OC3D0
Reset:	0	0	0	0	0	0	0	0

= Writes have no effect and the access terminates without a transfer error exception.

**Figure 16-5. Timer Output Compare 3 Data Register (TIMOC3D)**

Read: Anytime

Write: Anytime

OC3D[3:0] — Output Compare 3 Data Bits

When a successful channel 3 output compare occurs, these bits transfer to the Timer Port Data Register if the corresponding OC3Mx bits are set.

**NOTE:** *A successful channel 3 output compare overrides any channel 2:0 compares. For each OC3M bit that is set, the output compare action reflects the corresponding OC3D bit.*

Timer Modules (TIM1 and TIM2)

16.7.5 Timer Counter Registers

Address: TIM1 — 0x00ce\_0004  
 TIM2 — 0x00cf\_0004

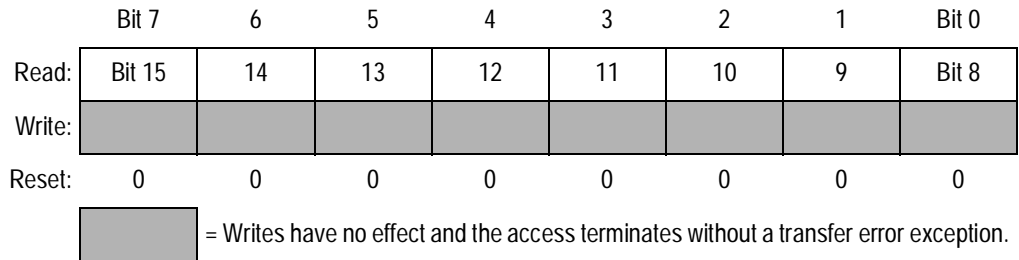

**Figure 16-6. Timer Counter Register High (TIMCNTH)**

Address: TIM1 — 0x00ce\_0005  
 TIM2 — 0x00cf\_0005

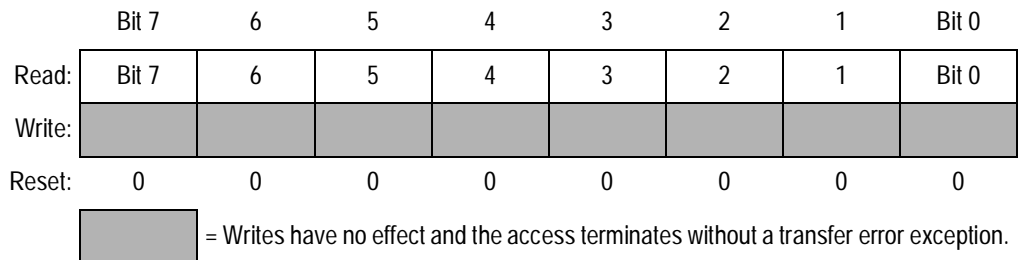

**Figure 16-7. Timer Counter Register Low (TIMCNTL)**

Read: Anytime

Write: Only in test (special) mode; has no effect in normal modes

To ensure coherent reading of the timer counter, such that a timer rollover does not occur between two back-to-back 8-bit reads, it is recommended that only half-word (16-bit) accesses be used.

A write to TIMCNT may have an extra cycle on the first count because the write is not synchronized with the prescaler clock. The write occurs at least one cycle before the synchronization of the prescaler clock.



### 16.7.6 Timer System Control Register 1

Address: TIM1 — 0x00ce\_0006  
TIM2 — 0x00cf\_0006

	Bit 7	6	5	4	3	2	1	Bit 0
Read:	TIMEN	0	0	TFFCA	0	0	0	0
Write:								
Reset:	0	0	0	0	0	0	0	0

= Writes have no effect and the access terminates without a transfer error exception.

**Figure 16-8. Timer System Control Register (TIMSCR1)**

Read: Anytime

Write: Anytime

**TIMEN** — Timer Enable Bit

TIMEN enables the timer. When the timer is disabled, only the registers are accessible. Clearing TIMEN reduces power consumption.

- 1 = Timer enabled
- 0 = Timer and timer counter disabled

**TFFCA** — Timer Fast Flag Clear All Bit

TFFCA enables fast clearing of the main timer interrupt flag registers (TIMFLG1 and TIMFLG2) and the PA Flag Register (TIMPAFLG). TFFCA eliminates the software overhead of a separate clear sequence.

When TFFCA is set:

- An input capture read or a write to an output compare channel clears the corresponding channel flag, CxF.
- Any access of the timer count registers (TIMCNTH/L) clears the TOF flag.
- Any access of the PA counter registers (TIMPACNT) clears both the PAOVF and PAIF flags in TIMPAFLG.

Writing logic 1s to the flags clears them only when TFFCA is clear.

- 1 = Fast flag clearing
- 0 = Normal flag clearing

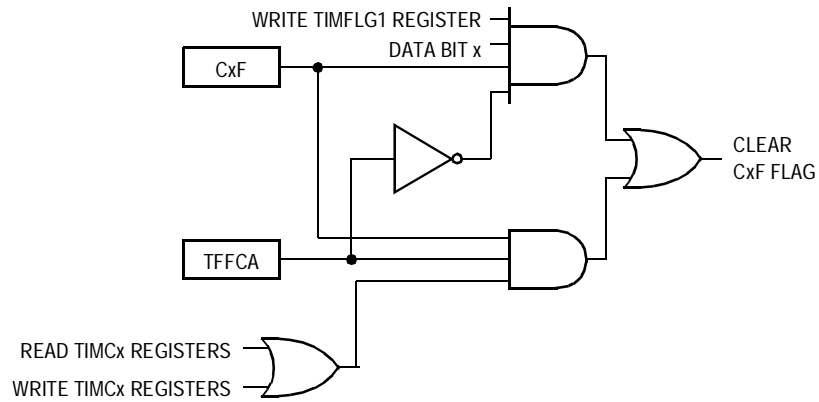

Figure 16-9. Fast Clear Flag Logic

### 16.7.7 Timer Toggle-On-Overflow Register

Address: TIM1 — 0x00ce\_0008  
 TIM2 — 0x00cf\_0008

	Bit 7	6	5	4	3	2	1	Bit 0
Read:	0	0	0	0	TOV3	TOV2	TOV1	TOV0
Write:								
Reset:	0	0	0	0	0	0	0	0

= Writes have no effect and the access terminates without a transfer error exception.

Figure 16-10. Timer Toggle-On-Overflow Register (TIMTOV)

Read: Anytime

Write: Anytime

TOV[3:0]— Toggle-On-Overflow Bits

TOV[3:0] toggles the output compare pin on overflow. This feature only takes effect when in output compare mode. When set, it takes precedence over forced output compare but not channel 3 override events.

- 1 = Toggle output compare pin on overflow feature enabled
- 0 = Toggle output compare pin on overflow feature disabled

### 16.7.8 Timer Control Register 1

Address: TIM1 — 0x00ce\_0009  
TIM2 — 0x00cf\_0009

	Bit 7	6	5	4	3	2	1	Bit 0
Read:	OM3	OL3	OM2	OL2	OM1	OL1	OM0	OL0
Write:								
Reset:	0	0	0	0	0	0	0	0

**Figure 16-11. Timer Control Register 1 (TIMCTL1)**

Read: Anytime

Write: Anytime

OMx/OLx — Output Mode/Output Level Bits

These bit pairs select the output action to be taken as a result of a successful output compare. When either OMx or OLx is set and the IOSx bit is set, the pin is an output regardless of the state of the corresponding DDR bit.

**Table 16-3. Output Compare Action Selection**

OMx:OLx	Action on Output Compare
00	Timer disconnected from output pin logic
01	Toggle OCx output line
10	Clear OCx output line
11	Set OCx line

Channel 3 shares a pin with the pulse accumulator input pin. To use the PAI input, clear both the OM3 and OL3 bits and clear the OC3M3 bit in the Output Compare 3 Mask Register.

**Timer Modules (TIM1 and TIM2)**

**16.7.9 Timer Control Register 2**

Address: TIM1 — 0x00ce\_000b  
 TIM2 — 0x00cf\_000b

	Bit 7	6	5	4	3	2	1	Bit 0
Read:	EDG3B	EDG3A	EDG2B	EDG2A	EDG1B	EDG1A	EDG0B	EDG10
Write:								
Reset:	0	0	0	0	0	0	0	0

**Figure 16-12. Timer Control Register 2 (TIMCTL2)**

Read: Anytime

Write: Anytime

EDGx[B:A] — Input Capture Edge Control Bits

These eight bit pairs configure the input capture edge detector circuits.

**Table 16-4. Input Capture Edge Selection**

EDGx[B:A]	Edge Selection
00	Input capture disabled
01	Input capture on rising edges only
10	Input capture on falling edges only
11	Input capture on any edge (rising or falling)

**16.7.10 Timer Interrupt Enable Register**

Address: TIM1 — 0x00ce\_000c  
TIM2 — 0x00cf\_000c

	Bit 7	6	5	4	3	2	1	Bit 0
Read:	0	0	0	0	C3I	C2I	C1I	C0I
Write:					C3I	C2I	C1I	C0I
Reset:	0	0	0	0	0	0	0	0

= Writes have no effect and the access terminates without a transfer error exception.

**Figure 16-13. Timer Interrupt Enable Register (TIMIE)**

Read: Anytime

Write: Anytime

C[3:0]I — Channel Interrupt Enable Bits

C[3:0]I enable the C[3:0]F flags in Timer Flag Register 1 to generate interrupt requests.

1 = Corresponding channel interrupt requests enabled

0 = Corresponding channel interrupt requests disabled

Timer Modules (TIM1 and TIM2)

16.7.11 Timer System Control Register 2

Address: TIM1 — 0x00ce\_000d  
 TIM2 — 0x00cf\_000d

	Bit 7	6	5	4	3	2	1	Bit 0
Read:	TOI	0	PUPT	RDPT	TCRE	PR2	PR1	PR0
Write:								
Reset:	0	0	0	0	0	0	0	0

= Writes have no effect and the access terminates without a transfer error exception.

Figure 16-14. Timer System Control Register 2 (TIMSCR2)

Read: Anytime

Write: Anytime

TOI — Timer Overflow Interrupt Enable Bit

TOI enables timer overflow interrupt requests.

1 = Overflow interrupt requests enabled

0 = Overflow interrupt requests disabled

PUPT — Timer Pullup Enable Bit

PUPT enables pullup resistors on the timer ports when the ports are configured as inputs.

1 = Pullup resistors enabled

0 = Pullup resistors disabled

RDPT — Timer Drive Reduction Bit

RDPT reduces the output driver size.

1 = Output drive reduction enabled

0 = Output drive reduction disabled

TCRE — Timer Counter Reset Enable Bit

TCRE enables a counter reset after a channel 3 compare.

1 = Counter reset enabled

0 = Counter reset disabled

**NOTE:** When the timer channel 3 registers contain \$0000 and TCRE is set, the timer counter registers remain at \$0000 all the time.

*When the timer channel 3 registers contain \$FFFF and TCRE is set, TOF never gets set even though the timer counter registers go from \$FFFF to \$0000.*

**PR[2:0] — Prescaler Bits**

These bits select the prescaler divisor for the timer counter.

**Table 16-5. Prescaler Selection**

PR[2:0]	Prescaler Divisor
000	1
001	2
010	4
011	8
100	16
101	32
110	64
111	128

**NOTE:** *The newly selected prescaled clock does not take effect until the next synchronized edge of the prescaled clock when the clock count transitions to \$0000.)*

Timer Modules (TIM1 and TIM2)

16.7.12 Timer Flag Register 1

Address: TIM1 — 0x00ce\_000e  
 TIM2 — 0x00cf\_000e

	Bit 7	6	5	4	3	2	1	Bit 0
Read:	0	0	0	0	C3F	C2F	C1F	C0F
Write:								
Reset:	0	0	0	0	0	0	0	0

= Writes have no effect and the access terminates without a transfer error exception.

Figure 16-15. Timer Flag Register 1 (TIMFLG1)

Read: Anytime

Write: Anytime; writing 1 clears flag; writing 0 has no effect

C[3:0]F — Channel Flags

A channel flag is set when an input capture or output compare event occurs. Clear a channel flag by writing a 1 to the flag.

**NOTE:** When the fast flag clear all bit, TFFCA, is set, an input capture read or an output compare write clears the corresponding channel flag. TFFCA is in timer System Control Register 1 (TIMSCR1).

When a channel flag is set, it does not inhibit subsequent output compares or input captures.



**16.7.13 Timer Flag Register 2**

Address: TIM1 — 0x00ce\_000f  
TIM2 — 0x00cf\_000f

	Bit 7	6	5	4	3	2	1	Bit 0
Read:	TOF	0	0	0	0	0	0	0
Write:								
Reset:	0	0	0	0	0	0	0	0

= Writes have no effect and the access terminates without a transfer error exception.

**Figure 16-16. Timer Flag Register 2 (TIMFLG2)**

Read: Anytime

Write: Anytime; writing 1 clears flag; writing 0 has no effect

TOF — Timer Overflow Flag

TOF is set when the timer counter rolls over from \$FFFF to \$0000. If the TOI bit in TIMSCR2 is also set, TOF generates an interrupt request. Clear TOF by writing a 1 to it.

1 = Timer overflow

0 = No timer overflow

**NOTE:** When the timer channel 3 registers contain \$FFFF and TCRE is set, TOF never gets set even though the timer counter registers go from \$FFFF to \$0000.

When the fast flag clear all bit, TFFCA, is set, any access to the timer counter registers clears Timer Flag Register 2. The TFFCA bit is in timer System Control Register 1 (TIMSCR1).

When TOF is set, it does not inhibit subsequent overflow events.

**Timer Modules (TIM1 and TIM2)**

**16.7.14 Timer Channel Registers**

Address: TIMC0H — 0x00ce\_0010/0x00cf\_0010  
 TIMC1H — 0x00ce\_0012/0x00cf\_0012  
 TIMC2H — 0x00ce\_0014/0x00cf\_0014  
 TIMC3H — 0x00ce\_0016/0x00cf\_0016

	Bit 7	6	5	4	3	2	1	Bit 0
Read:	Bit 15	14	13	12	11	10	9	Bit 8
Write:								
Reset:	0	0	0	0	0	0	0	0

**Figure 16-17. Timer Channel [0:3] Register High (TIMCxH)**

Address: TIMC0L — 0x00ce\_0011/0x00cf\_0011  
 TIMC1L — 0x00ce\_0013/0x00cf\_0013  
 TIMC2L — 0x00ce\_0015/0x00cf\_0015  
 TIMC3L — 0x00ce\_0017/0x00cf\_0017

	Bit 7	6	5	4	3	2	1	Bit 0
Read:	Bit 7	6	5	4	3	2	1	Bit 0
Write:								
Reset:	0	0	0	0	0	0	0	0

**Figure 16-18. Timer Channel [0:3] Register Low (TIMCxL)**

Read: Anytime

Write: Output compare channel, anytime; input capture channel, no effect

When a channel is configured for input capture (IOSx = 0), the timer channel registers latch the value of the free-running counter when a defined transition occurs on the corresponding input capture pin.

When a channel is configured for output compare (IOSx = 1), the timer channel registers contain the output compare value.

To ensure coherent reading of the timer counter, such that a timer rollover does not occur between back-to-back 8-bit reads, it is recommended that only half-word (16-bit) accesses be used.

### 16.7.15 Pulse Accumulator Control Register

Address: TIM1 — 0x00ce\_0018  
TIM2 — 0x00cf\_0018

	Bit 7	6	5	4	3	2	1	Bit 0
Read:	0	PAE	PAMOD	PEDGE	CLK1	CLK0	PAOVI	PAI
Write:								
Reset:	0	0	0	0	0	0	0	0

= Writes have no effect and the access terminates without a transfer error exception.

**Figure 16-19. Pulse Accumulator Control Register (TIMPACTL)**

Read: Anytime

Write: Anytime

PAE — Pulse Accumulator Enable Bit

PAE enables the pulse accumulator.

1 = Pulse accumulator enabled

0 = Pulse accumulator disabled

**NOTE:** *The pulse accumulator can operate in event mode even when the timer enable bit, TIMEN, is clear.*

PAMOD — Pulse Accumulator Mode Bit

PAMOD selects event counter mode or gated time accumulation mode.

1 = Gated time accumulation mode

0 = Event counter mode

PEDGE — Pulse Accumulator Edge Bit

PEDGE selects falling or rising edges on the PAI pin to increment the counter.

In event counter mode (PAMOD = 0):

1 = Rising PAI edge increments counter

0 = Falling PAI edge increments counter

**Timer Modules (TIM1 and TIM2)**

In gated time accumulation mode (PAMOD = 1):

1 = Low PAI input enables divide-by-64 clock to pulse accumulator and trailing rising edge on PAI sets PAIF flag.

0 = High PAI input enables divide-by-64 clock to pulse accumulator and trailing falling edge on PAI sets PAIF flag.

**NOTE:** *The timer prescaler generates the divide-by-64 clock. If the timer is not active, there is no divide-by-64 clock.*

To operate in gated time accumulation mode:

1. Apply logic 0 to  $\overline{\text{RESET}}$  pin.
2. Initialize registers for pulse accumulator mode test.
3. Apply appropriate level to PAI pin.
4. Enable timer.

CLK[1:0] — Clock Select Bits

CLK[1:0] select the timer counter input clock as shown in [Table 16-6](#).

**Table 16-6. Clock Selection**

CLK[1:0]	Timer Counter Clock <sup>(1)</sup>
00	Timer prescaler clock <sup>(2)</sup>
01	PACLK
10	PACLK/256
11	PACLK/65536

1. Changing the CLKx bits causes an immediate change in the timer counter clock input.  
 2. When PAE = 0, the timer prescaler clock is always the timer counter clock.

PAOVI — Pulse Accumulator Overflow Interrupt Enable Bit

PAOVI enables the PAOVF flag to generate interrupt requests.

- 1 = PAOVF interrupt requests enabled
- 0 = PAOVF interrupt requests disabled

PAI — Pulse Accumulator Input Interrupt Enable Bit

PAI enables the PAIF flag to generate interrupt requests.

- 1 = PAIF interrupt requests enabled
- 0 = PAIF interrupt requests disabled

### 16.7.16 Pulse Accumulator Flag Register

Address: TIM1 — 0x00ce\_0019  
TIM2 — 0x00cf\_0019

	Bit 7	6	5	4	3	2	1	Bit 0
Read:	0	0	0	0	0	0	PAOVF	PAIF
Write:								
Reset:	0	0	0	0	0	0	0	0

= Writes have no effect and the access terminates without a transfer error exception.

**Figure 16-20. Pulse Accumulator Flag Register (TIMPAFLG)**

Read: Anytime

Write: Anytime; writing 1 clears the flag; writing 0 has no effect

PAOVF — Pulse Accumulator Overflow Flag

PAOVF is set when the 16-bit pulse accumulator rolls over from \$FFFF to \$0000. If the PAOVI bit in TIMPACTL is also set, PAOVF generates an interrupt request. Clear PAOVF by writing a 1 to it.

- 1 = Pulse accumulator overflow
- 0 = No pulse accumulator overflow

PAIF — Pulse Accumulator Input Flag

PAIF is set when the selected edge is detected at the PAI pin. In event counter mode, the event edge sets PAIF. In gated time accumulation mode, the trailing edge of the gate signal at the PAI pin sets PAIF. If the PAI bit in TIMPACTL is also set, PAIF generates an interrupt request. Clear PAIF by writing a 1 to it.

- 1 = Active PAI input
- 0 = No active PAI input

**NOTE:** When the fast flag clear all enable bit, TFFCA, is set, any access to the pulse accumulator counter registers clears all the flags in TIMPAFLG.

Timer Modules (TIM1 and TIM2)

16.7.17 Pulse Accumulator Counter Registers

Address: TIM1 — 0x00ce\_001a  
 TIM2 — 0x00cf\_001a

	Bit 7	6	5	4	3	2	1	Bit 0
Read:	Bit 15	14	13	12	11	10	9	Bit 8
Write:								
Reset:	0	0	0	0	0	0	0	0

Figure 16-21. Pulse Accumulator Counter Register High (TIMPACNTH)

Address: TIM1 — 0x00ce\_001b  
 TIM2 — 0x00cf\_001b

	Bit 7	6	5	4	3	2	1	Bit 0
Read:	Bit 7	6	5	4	3	2	1	Bit 0
Write:								
Reset:	0	0	0	0	0	0	0	0

Figure 16-22. Pulse Accumulator Counter Register Low (TIMPACNTL)

Read: Anytime

Write: Anytime

These registers contain the number of active input edges on the PAI pin since the last reset.

**NOTE:** Reading the pulse accumulator counter registers immediately after an active edge on the PAI pin may miss the last count since the input first has to be synchronized with the bus clock.

To ensure coherent reading of the PA counter, such that the counter does not increment between back-to-back 8-bit reads, it is recommended that only half-word (16-bit) accesses be used.

**16.7.18 Timer Port Data Register**

Address: TIM1 — 0x00ce\_001d  
TIM2 — 0x00cf\_001d

	Bit 7	6	5	4	3	2	1	Bit 0
Read:	0	0	0	0	PORTT3	PORTT2	PORTT1	PORTT0
Write:								
Reset:	0	0	0	0	0	0	0	0

= Writes have no effect and the access terminates without a transfer error exception.

**Figure 16-23. Timer Port Data Register (TIMPORT)**

Read: Anytime; read pin state when corresponding TIMDDR bit is 0;  
read pin driver state when corresponding TIMDDR bit is 1

Write: Anytime

PORTT[3:0] — Timer Port Input Capture/Output Compare Data Bits

Data written to TIMPORT is buffered and drives the pins only when they are configured as general-purpose outputs.

Reading an input (DDR bit = 0) reads the pin state; reading an output (DDR bit = 1) reads the latch.

Writing to a pin configured as a timer output does not change the pin state.

Timer Modules (TIM1 and TIM2)

16.7.19 Timer Port Data Direction Register

Address: TIM1 — 0x00ce\_001e  
 TIM2 — 0x00cf\_001e

	Bit 7	6	5	4	3	2	1	Bit 0
Read:	0	0	0	0	DDRT3	DDRT2	DDRT1	DDRT0
Write:								
Reset:	0	0	0	0	0	0	0	0
Timer function:					IC/OC3	IC/OC2	IC/OC1	IC/OC0
Pulse accumulator function:					PAI			

= Writes have no effect and the access terminates without a transfer error exception.

**Figure 16-24. Timer Port Data Direction Register (TIMDDR)**

Read: Anytime

Write: Anytime

DDRT[3:0] — TIMPORT Data Direction Bits

These bits control the port logic of TIMPORT. Reset clears the Timer Port Data Direction Register, configuring all timer port pins as inputs.

- 1 = Corresponding pin configured as output
- 0 = Corresponding pin configured as input



### 16.7.20 Timer Test Register

The Timer Test Register (TIMTST) is only for factory testing. When not in test mode, TIMTST is read-only.

Address: TIM1 — 0x00ce\_001f  
TIM2 — 0x00cf\_001f

	Bit 7	6	5	4	3	2	1	Bit 0
Read:	0	0	0	0	0	0	0	0
Write:								
Reset:	0	0	0	0	0	0	0	0

= Writes have no effect and the access terminates without a transfer error exception.

**Figure 16-25. Timer Test Register (TIMTST)**

## 16.8 Functional Description

The timer module is a 16-bit, 4-channel timer with input capture and output compare functions and a pulse accumulator.

### 16.8.1 Prescaler

The prescaler divides the module clock by 1, 2, 4, 8, 16, 32, 64, or 128. The PR[2:0] bits in TIMSCR2 select the prescaler divisor.

### 16.8.2 Input Capture

Clearing an I/O select bit, IOSx, configures channel x as an input capture channel. The input capture function captures the time at which an external event occurs. When an active edge occurs on the pin of an input capture channel, the timer transfers the value in the timer counter into the timer channel registers, TIMCxH and TIMCxL.

The minimum pulse width for the input capture input is greater than two module clocks.

The input capture function does not force data direction. The Timer Port Data Direction Register controls the data direction of an input capture pin. Pin conditions such as rising or falling edges can trigger an input capture only on a pin configured as an input.

An input capture on channel x sets the CxF flag. The CxI bit enables the CxF flag to generate interrupt requests.

### 16.8.3 Output Compare

Setting an I/O select bit, IOSx, configures channel x as an output compare channel. The output compare function can generate a periodic pulse with a programmable polarity, duration, and frequency. When the timer counter reaches the value in the channel registers of an output compare channel, the timer can set, clear, or toggle the channel pin. An output compare on channel x sets the CxF flag. The CxI bit enables the CxF flag to generate interrupt requests.

The output mode and level bits, OMx and OLx, select, set, clear, or toggle on output compare. Clearing both OMx and OLx disconnects the pin from the output logic.

Setting a force output compare bit, FOCx, causes an output compare on channel x. A forced output compare does not set the channel flag.

A successful output compare on channel 3 overrides output compares on all other output compare channels. A channel 3 output compare can cause bits in the Output Compare 3 Data Register to transfer to the Timer Port Data Register, depending on the Output Compare 3 Mask Register. The Output Compare 3 Mask Register masks the bits in the Output Compare 3 Data Register. The timer counter reset enable bit, TCRE, enables channel 3 output compares to reset the timer counter. A channel 3 output compare can reset the timer counter even if the OC3/PAI pin is being used as the pulse accumulator input.

An output compare overrides the data direction bit of the output compare pin but does not change the state of the data direction bit.

Writing to the timer port bit of an output compare pin does not affect the pin state. The value written is stored in an internal latch. When the pin becomes available for general-purpose output, the last value written to the bit appears at the pin.

#### 16.8.4 Pulse Accumulator

The pulse accumulator (PA) is a 16-bit counter that can operate in two modes:

1. Event counter mode — Counts edges of selected polarity on the pulse accumulator input pin, PAI
2. Gated time accumulation mode — Counts pulses from a divide-by-64 clock

The PA mode bit, PAMOD, selects the mode of operation.

The minimum pulse width for the PAI input is greater than two module clocks.

##### 16.8.4.1 Event Counter Mode

Clearing the PAMOD bit configures the PA for event counter operation. An active edge on the PAI pin increments the PA. The PA edge bit, PEDGE, selects falling edges or rising edges to increment the PA.

An active edge on the PAI pin sets the PA input flag, PAIF. The PA input interrupt enable bit, PAI, enables the PAIF flag to generate interrupt requests.

**NOTE:** *The PAI input and timer channel 3 use the same pin. To use the PAI input, disconnect it from the output logic by clearing the channel 3 output mode and output level bits, OM3 and OL3. Also clear the channel 3 output compare 3 mask bit, OC3M3.*

The PA counter registers, TIMPACNTH/L, reflect the number of active input edges on the PAI pin since the last reset.

Timer Modules (TIM1 and TIM2)

The PA overflow flag, PAOVF, is set when the PA rolls over from \$FFFF to \$0000. The PA overflow interrupt enable bit, PAOVI, enables the PAOVF flag to generate interrupt requests.

**NOTE:** *The PA can operate in event counter mode even when the timer enable bit, TIMEN, is clear.*

16.8.4.2 Gated Time Accumulation Mode

Setting the PAMOD bit configures the PA for gated time accumulation operation. An active level on the PAI pin enables a divide-by-64 clock to drive the PA. The PA edge bit, PEDGE, selects low levels or high levels to enable the divide-by-64 clock.

The trailing edge of the active level at the PAI pin sets the PA input flag, PAIF. The PA input interrupt enable bit, PAI, enables the PAIF flag to generate interrupt requests.

**NOTE:** *The PAI input and timer channel 3 use the same pin. To use the PAI input, disconnect it from the output logic by clearing the channel 3 output mode and output level bits, OM3 and OL3. Also clear the channel 3 output compare mask bit, OC3M3.*

The PA counter registers, TIMPACNTH/L reflect the number of pulses from the divide-by-64 clock since the last reset.

**NOTE:** *The timer prescaler generates the divide-by-64 clock. If the timer is not active, there is no divide-by-64 clock.*

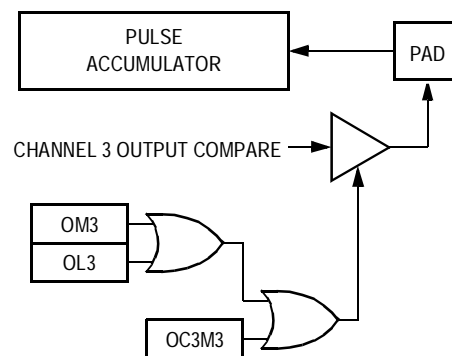

Figure 16-26. Channel 3 Output Compare/Pulse Accumulator Logic

### 16.8.5 General-Purpose I/O Ports

An I/O pin used by the timer defaults to general-purpose I/O unless an internal function which uses that pin is enabled.

The timer pins can be configured for either an input capture function or an output compare function. The IOSx bits in the Timer IC/OC Select Register configure the timer port pins as either input capture or output compare pins.

The Timer Port Data Direction Register controls the data direction of an input capture pin. External pin conditions trigger input captures on input capture pins configured as inputs.

To configure a pin for input capture:

1. Clear the pin's IOS bit in TIMIOS.
2. Clear the pin's DDR bit in TIMDDR.
3. Write to TIMCTL2 to select the input edge to detect.

TIMDDR does not affect the data direction of an output compare pin. The output compare function overrides the Data Direction Register but does not affect the state of the Data Direction Register.

To configure a pin for output compare:

1. Set the pin's IOS bit in TIMIOS.
2. Write the output compare value to TIMCxH/L.
3. Clear the pin's DDR bit in TIMDDR.
4. Write to the OMx/OLx bits in TIMCTL1 to select the output action.

**Table 16-7** shows how various timer settings affect pin functionality.

**Timer Modules (TIM1 and TIM2)**
**Table 16-7. Timer Settings and Pin Functions**

TIMEN	DDR <sup>(1)</sup>	TIMIOS	EDGx [B:A]	OMx/OLx <sup>(2)</sup>	OC3Mx <sup>(3)</sup>	Pin Data Direction	Pin Driven by	Pin Function	Comments
0	0	X <sup>(4)</sup>	X	X	X	In	Ext.	Digital input	Timer disabled by TIMEN = 0
0	1	X	X	X	X	Out	Data reg.	Digital output	Timer disabled by TIMEN = 0
1	0	0 (IC)	0 (IC disabled)	X	0	In	Ext.	Digital input	Input capture disabled by EDGx setting
1	1	0	0	X	0	Out	Data reg.	Digital output	Input capture disabled by EDGx setting
1	0	0	<>0	X	0	In	Ext.	IC and digital input	Normal settings for input capture
1	1	0	<>0	X	0	Out	Data reg.	Digital output	Input capture of data driven to output pin by CPU
1	0	0	<>0	X	1	In	Ext.	IC and digital input	OC3M setting has no effect because IOS = 0
1	1	0	<>0	X	1	Out	Data reg.	Digital output	OC3M setting has no effect because IOS = 0; input capture of data driven to output pin by CPU
1	0	1 (OC)	X <sup>(3)</sup>	0 <sup>(5)</sup>	0	In	Ext.	Digital input	Output compare takes place but does not affect the pin because of the OMx/OLx setting
1	1	1	X	0	0	Out	Data reg.	Digital output	Output compare takes place but does not affect the pin because of the OMx/OLx setting
1	0	1	X	<>0	0	Out	OC action	Output compare	Pin readable only if DDR = 0 <sup>(6)</sup>
1	1	1	X	<>0	0	Out	OC action	Output compare	Pin driven by OC action <sup>(6)</sup>
1	0	1	X	X	1	Out	OC action/OC3Dx	Output compare (ch 3)	Pin readable only if DDR = 0 <sup>(6)</sup>
1	1	1	X	X	1	Out	OC action/OC3Dx	Output compare/OC3Dx (ch 3)	Pin driven by channel OC action and OC3Dx via channel 3 OC <sup>(6)</sup>

- When DDR set the pin as input (0), reading the data register will return the state of the pin. When DDR set the pin as output (1), reading the data register will return the content of the data latch. Pin conditions such as rising or falling edges can trigger an input capture on a pin configured as an input.
- OMx/OLx bit pairs select the output action to be taken as a result of a successful output compare. When either OMx or OLx is set and the IOSx bit is set, the pin is an output regardless of the state of the corresponding DDR bit.
- Setting an OC3M bit configures the corresponding TIMPORT pin to be output. OC3Mx makes the timer port pin an output regardless of the data direction bit when the pin is configured for output compare (IOSx = 1). The OC3Mx bits do not change the state of the TIMDDR bits.
- X = Don't care
- An output compare overrides the data direction bit of the output compare pin but does not change the state of the data direction bit. Enabling output compare disables data register drive of the pin.
- A successful output compare on channel 3 causes an output value determined by OC3Dx value to temporarily override the output compare pin state of any other output compare channel. The next OC action for the specific channel will still be output to the pin. A channel 3 output compare can cause bits in the output compare 3 data register to transfer to the timer port data register, depending on the output compare 3 mask register.

## 16.9 Reset

Reset initializes the timer registers to a known startup state as described in [16.7 Memory Map and Registers](#).

## 16.10 Interrupts

[Table 16-8](#) lists the interrupt requests generated by the timer.

**Table 16-8. Timer Interrupt Requests**

Interrupt Request	Flag	Enable Bit
Channel 3 IC/OC	C3F	C3I
Channel 2 IC/OC	C2F	C2I
Channel 1 IC/OC	C1F	C1I
Channel 0 IC/OC	C0F	C0I
PA overflow	PAOVF	PAOVI
PA input	PAIF	PAI
Timer overflow	TOF	TOI

### 16.10.1 Timer Channel Interrupts (CxF)

A channel flag is set when an input capture or output compare event occurs. Clear a channel flag by writing a 1 to the flag.

**NOTE:** *When the fast flag clear all bit, TFFCA, is set, an input capture read or an output compare write clears the corresponding channel flag. TFFCA is in Timer System Control Register 1 (TIMSCR1).*

*When a channel flag is set, it does not inhibit subsequent output compares or input captures*

## Timer Modules (TIM1 and TIM2)

## 16.10.2 Pulse Accumulator Overflow (PAOVF)

PAOVF is set when the 16-bit pulse accumulator rolls over from \$FFFF to \$0000. If the PAOVI bit in TIMPACTL is also set, PAOVF generates an interrupt request. Clear PAOVF by writing a 1 to this flag.

**NOTE:** *When the fast flag clear all enable bit, TFFCA, is set, any access to the pulse accumulator counter registers clears all the flags in TIMPAFLG.*

## 16.10.3 Pulse Accumulator Input (PAIF)

PAIF is set when the selected edge is detected at the PAI pin. In event counter mode, the event edge sets PAIF. In gated time accumulation mode, the trailing edge of the gate signal at the PAI pin sets PAIF. If the PAI bit in TIMPACTL is also set, PAIF generates an interrupt request. Clear PAIF by writing a 1 to this flag.

**NOTE:** *When the fast flag clear all enable bit, TFFCA, is set, any access to the pulse accumulator counter registers clears all the flags in TIMPAFLG.*

## 16.10.4 Timer Overflow (TOF)

TOF is set when the timer counter rolls over from \$FFFF to \$0000. If the TOI bit in TIMSCR2 is also set, TOF generates an interrupt request. Clear TOF by writing a 1 to this flag.

**NOTE:** *When the timer channel 3 registers contain \$FFFF and TCRE is set, TOF never gets set even though the timer counter registers go from \$FFFF to \$0000.*

*When the fast flag clear all bit, TFFCA, is set, any access to the timer counter registers clears Timer Flag Register 2. The TFFCA bit is in Timer System Control Register 1 (TIMSCR1).*

*When TOF is set, it does not inhibit future overflow events.*



## **Section 17. Serial Communications Interface Modules (SCI1 and SCI2)**

### **17.1 Contents**

17.2	Introduction .....	354
17.3	Features .....	355
17.4	Block Diagram .....	356
17.5	Modes of Operation .....	357
17.5.1	Doze Mode .....	357
17.5.2	Stop Mode .....	357
17.6	Signal Description .....	358
17.6.1	RXD .....	358
17.6.2	TXD .....	358
17.7	Memory Map and Registers .....	358
17.7.1	SCI Baud Rate Registers .....	360
17.7.2	SCI Control Register 1 .....	361
17.7.3	SCI Control Register 2 .....	364
17.7.4	SCI Status Register 1 .....	366
17.7.5	SCI Status Register 2 .....	369
17.7.6	SCI Data Registers .....	370
17.7.7	SCI Pullup and Reduced Drive Register .....	371
17.7.8	SCI Port Data Register .....	372
17.7.9	SCI Data Direction Register .....	373
17.8	Functional Description .....	374
17.9	Data Format .....	374
17.10	Baud Rate Generation .....	375
17.11	Transmitter .....	376
17.11.1	Frame Length .....	377
17.11.2	Transmitting a Frame .....	378

17.11.3	Break Frames . . . . .	380
17.11.4	Idle Frames . . . . .	380
17.12	Receiver . . . . .	381
17.12.1	Frame Length . . . . .	381
17.12.2	Receiving a Frame . . . . .	381
17.12.3	Data Sampling . . . . .	382
17.12.4	Framing Errors . . . . .	387
17.12.5	Baud Rate Tolerance . . . . .	387
17.12.5.1	Slow Data Tolerance . . . . .	388
17.12.5.2	Fast Data Tolerance . . . . .	389
17.12.6	Receiver Wakeup . . . . .	390
17.12.6.1	Idle Input Line Wakeup (WAKE = 0) . . . . .	390
17.12.6.2	Address Mark Wakeup (WAKE = 1) . . . . .	391
17.13	Single-Wire Operation . . . . .	392
17.14	Loop Operation . . . . .	393
17.15	I/O Ports . . . . .	394
17.16	Reset . . . . .	395
17.17	Interrupts . . . . .	395
17.17.1	Transmit Data Register Empty . . . . .	395
17.17.2	Transmission Complete . . . . .	395
17.17.3	Receive Data Register Full . . . . .	396
17.17.4	Idle Receiver Input . . . . .	396
17.17.5	Overrun . . . . .	396

## 17.2 Introduction

The serial communications interface (SCI) allows asynchronous serial communications with peripheral devices and other microcontroller units (MCU).

The MMC2114, MMC2113, and MMC2112 have two identical SCI modules, each with its own control registers and input/output (I/O) pins.

In the text that follows, SCI register names are denoted generically. Thus, SCI<sub>PORT</sub> refers interchangeably to SCI<sub>1PORT</sub> and SCI<sub>2PORT</sub>, the port data registers for SCI<sub>1</sub> and SCI<sub>2</sub>, respectively.

## 17.3 Features

Features of each SCI module include:

- Full-duplex operation
- Standard mark/space non-return-to-zero (NRZ) format
- 13-bit baud rate selection
- Programmable 8-bit or 9-bit data format
- Separately enabled transmitter and receiver
- Separate receiver and transmitter central processor unit (CPU) interrupt requests
- Programmable transmitter output polarity
- Two receiver wakeup methods:
  - Idle line wakeup
  - Address mark wakeup
- Interrupt-driven operation with eight flags:
  - Transmitter empty
  - Transmission complete
  - Receiver full
  - Idle receiver input
  - Receiver overrun
  - Noise error
  - Framing error
  - Parity error
- Receiver framing error detection
- Hardware parity checking
- 1/16 bit-time noise detection
- General-purpose, I/O capability

### 17.4 Block Diagram

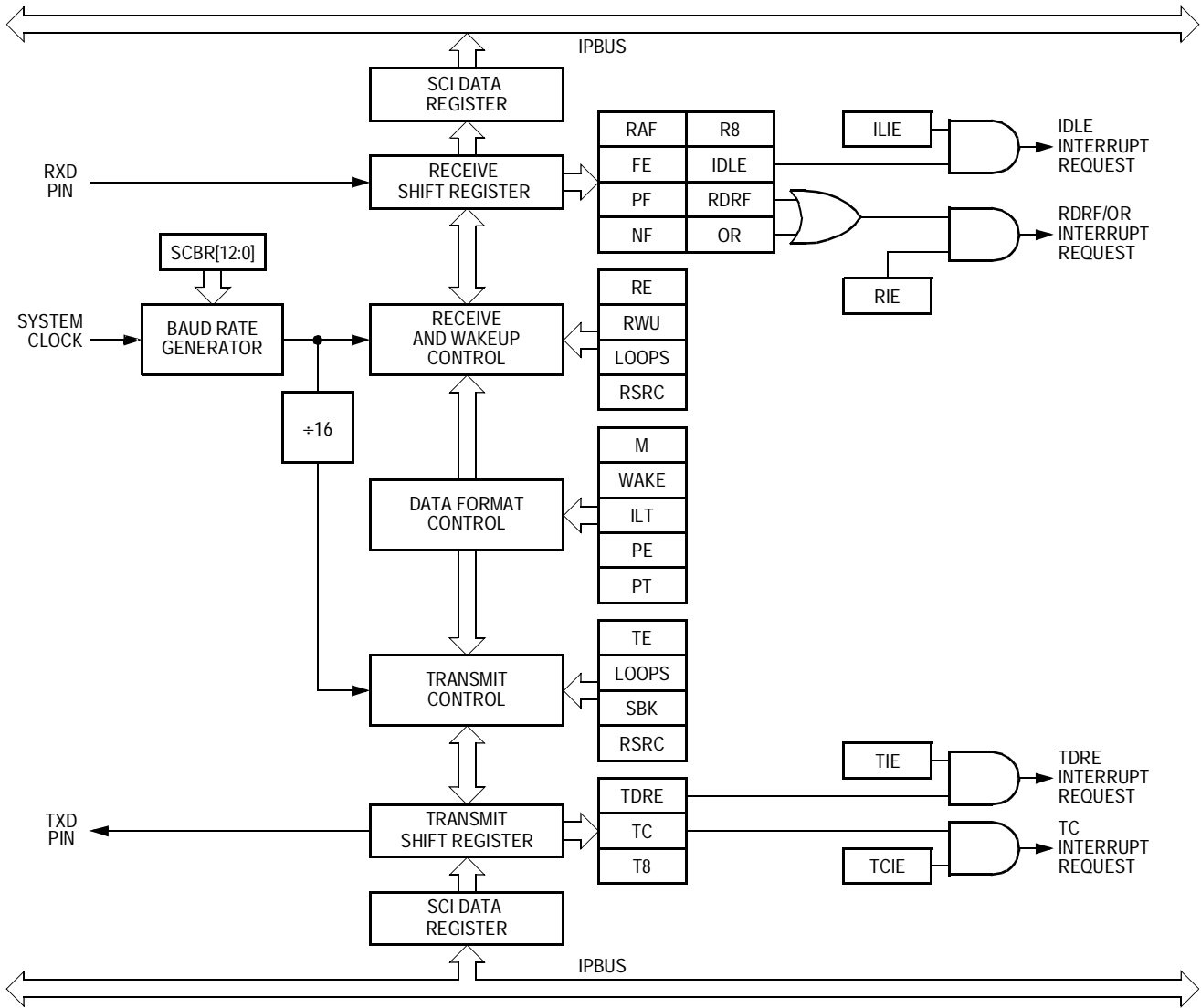

Figure 17-1. SCI Block Diagram

## 17.5 Modes of Operation

SCI operation is identical in run, special, and emulation modes. The SCI has two low-power modes, doze and stop.

**NOTE:** *Run mode is the normal mode of operation and the WAIT instruction does not affect SCI operation.*

### 17.5.1 Doze Mode

When the SCIDOZ bit in the SCI Pullup and Reduced Drive (SCIPURD) Register is set, the DOZE instruction stops the SCI clock and puts the SCI in a low-power state. The DOZE instruction does not affect SCI register states. Any transmission or reception in progress stops at doze mode entry and resumes when an internal or external interrupt request brings the CPU out of doze mode. Exiting doze mode by reset aborts any transmission or reception in progress and resets the SCI. See [17.7.7 SCI Pullup and Reduced Drive Register](#).

When the SCIDOZ bit is clear, execution of the DOZE instruction has no effect on the SCI. Normal module operation continues, allowing any SCI interrupt to bring the CPU out of doze mode.

### 17.5.2 Stop Mode

The STOP instruction stops the SCI clock and puts the SCI in a low-power state. The STOP instruction does not affect SCI register states. Any transmission or reception in progress halts at stop mode entry and resumes when an external interrupt request brings the CPU out of stop mode. Exiting stop mode by reset aborts any transmission or reception in progress and resets the SCI.

## 17.6 Signal Description

**Table 17-1** gives an overview of the signals which are described here.

**Table 17-1. Signal Properties**

Name	Function	Port	Reset State	Default Pullup State
RXD	Receive data pin	SCIPORT0	0	Disabled
TXD	Transmit data pin	SCIPORT1	0	Disabled

### 17.6.1 RXD

RXD is the SCI receiver pin. RXD is available for general-purpose I/O when it is not configured for receiver operation.

### 17.6.2 TXD

TXD is the SCI transmitter pin. TXD is available for general-purpose I/O when it is not configured for transmitter operation.

## 17.7 Memory Map and Registers

**Table 17-1** shows the SCI memory map.

**NOTE:** *Reading unimplemented addresses (0x00cc\_000b through 0x00cc\_000f) returns 0s. Writing to unimplemented addresses has no effect. Accessing unimplemented addresses does not generate an error response.*

**Table 17-2. Serial Communications Interface Module Memory Map<sup>(1)</sup>**

Address		Bits 7–0	Access <sup>(2)</sup>
SCI1	SCI2		
0x00cc_0000	0x00cd_0000	SCI Baud Register High (SCIBDH)	S/U
0x00cc_0001	0x00cd_0001	SCI Baud Register Low (SCIBDL)	S/U
0x00cc_0002	0x00cd_0002	SCI Control Register 1 (SCICR1)	S/U
0x00cc_0003	0x00cd_0003	SCI Control Register 2 (SCICR2)	S/U
0x00cc_0004	0x00cd_0004	SCI Status Register 1 (SCISR1)	S/U
0x00cc_0005	0x00cd_0005	SCI Status Register 2 (SCISR2)	S/U
0x00cc_0006	0x00cd_0006	SCI Data Register High (SCIDRH)	S/U
0x00cc_0007	0x00cd_0007	SCI Data Register Low (SCIDRL)	S/U
0x00cc_0008	0x00cd_0008	SCI Pullup and Reduced Drive Register (SCIPURD)	S/U
0x00cc_0009	0x00cd_0009	SCI Port Data Register (SCIPOINT)	S/U
0x00cc_000a	0x00cd_000a	SCI Data Direction Register (SCIDDR)	S/U
0x00cc_000b to 0x00cc_000f	0x00cd_000b to 0x00cd_000f	Reserved <sup>(3)</sup>	S/U

1. Each module is assigned 64 Kbytes of address space, all of which may not be decoded. Accesses outside of the specified module memory map generate a bus error exception.
2. S/U = CPU supervisor or user mode access. User mode accesses to supervisor only addresses have no effect and result in a cycle termination transfer error.
3. Within the specified module memory map, accessing reserved addresses does not generate a bus error exception. Reads of reserved addresses return 0s and writes have no effect.

17.7.1 SCI Baud Rate Registers

Address: SCI1 — 0x00cc\_0000  
 SCI2 — 0x00cd\_0000

	Bit 7	6	5	4	3	2	1	Bit 0
Read:	0	0	0	SBR12	SBR11	SBR10	SBR9	SBR8
Write:								
Reset:	0	0	0	0	0	0	0	0

= Writes have no effect and the access terminates without a transfer error exception.

**Figure 17-2. SCI Baud Rate Register High (SCIBDH)**

Address: SCI1 — 0x00cc\_0001  
 SCI2 — 0x00cd\_0001

	Bit 7	6	5	4	3	2	1	Bit 0
Read:	SBR7	SBR6	SBR5	SBR4	SBR3	SBR2	SBR1	SBR0
Write:								
Reset:	0	0	0	0	0	1	0	0

**Figure 17-3. SCI Baud Rate Register Low (SCIBDL)**

Read: Anytime

Write: Anytime

SBR[12:8], SBR[7:0] — SCI Baud Rate Bits

These read/write bits control the SCI baud rate:

$$\text{SCI baud rate} = \frac{f_{\text{sys}}}{16 \times \text{SBR}[12:0]}$$

where:

$$1 \leq \text{SBR}[12:0] \leq 8191$$

**NOTE:** The baud rate generator is disabled until the TE bit or the RE bit in SCICR2 is set for the first time after reset. The baud rate generator is disabled when SBR[12:0] = 0.

Writing to SCIBDH has no effect without also writing to SCIBDL. Writing to SCIBDH puts the data in a temporary location until data is written to SCIBDL.



## 17.7.2 SCI Control Register 1

Address: SCI1 — 0x00cc\_0002  
SCI2 — 0x00cd\_0002

	Bit 7	6	5	4	3	2	1	Bit 0
Read:	LOOPS	WOMS	RSRC	M	WAKE	ILT	PE	PT
Write:								
Reset:	0	0	0	0	0	0	0	0

**Figure 17-4. SCI Control Register 1 (SCICR1)**

Read: Anytime

Write: Anytime

**LOOPS** — Loop Select Bit

This read/write control bit switches the SCI between normal mode and loop mode. Reset clears LOOPS.

- 1 = Loop mode SCI operation
- 0 = Normal mode SCI operation

The SCI operates normally (LOOPS = 0, RSRC = X) when the output of its transmitter is connected to the TXD pin, and the input of its receiver is connected to the RXD pin.

In loop mode (LOOPS = 1, RSRC = 0), the input to the SCI receiver is internally disconnected from the RXD pin logic and instead connected to the output of the SCI transmitter. The behavior of TXD is governed by the DDRSC1 bit in SCIDDR. If DDRSC1 = 1, the TXD pin is driven with the output of the SCI transmitter. If DDRSC1 = 0, the TXD pin idles high. See [17.14 Loop Operation](#) for additional information.

For either loop mode or single-wire mode to function, both the SCI receiver and transmitter must be enabled by setting the RE and TE bits in SCIXCR2.

**NOTE:** *The RXD pin becomes general-purpose I/O when LOOPS = 1, regardless of the state of the RSRC bit. DDRSC0 in SCIDDR is the data direction bit for the RXD pin.*

[Table 17-3](#) shows how the LOOPS, RSRC, and DDRSC0 bits affect SCI operation and the configuration of the RXD and TXD pins.

**Table 17-3. SCI Normal, Loop, and Single-Wire Mode Pin Configurations**

LOOPS	RSRC	SCI Mode	Receiver Input	RXD Pin Function	DDRSCO	Transmitter Output	TXD Pin Function
0	X	Normal	Tied to RXD input buffer	Receive pin	X	Tied to TXD output driver	Transmit pin
1	0	Loop	Tied to transmitter output	General-purpose I/O	0	Tied to receiver input only	None (idles high)
					1	Tied to receiver input and TXD output driver	Transmit pin
	1	Single-wire	Tied to TXD		0	No connection	Receive pin
					1	Tied to TXD output driver	Transmit pin

**WOMS — Wired-OR Mode Select Bit**

This read/write bit configures the TXD and RXD pins for open-drain operation. This allows all of the TXD pins to be tied together in a multiple-transmitter system. WOMS also affects the TXD and RXD pins when they are general-purpose outputs. External pullup resistors are necessary on open-drain outputs. Reset clears WOMS.

- 1 = TXD and RXD pins open-drain when outputs
- 0 = TXD and RXD pins CMOS drive when outputs

**RSRC — Receiver Source Bit**

This read/write bit selects the internal feedback path to the receiver input when LOOPS = 1. Reset clears RSRC.

- 1 = Receiver input tied to TXD pin when LOOPS = 1
- 0 = Receiver input tied to transmitter output when LOOPS = 1

**M — Data Format Mode Bit**

This read/write bit selects 11-bit or 10-bit frames. Reset clears M.

- 1 = Frames have 1 start bit, 9 data bits, and 1 stop bit.
- 0 = Frames have 1 start bit, 8 data bits, and 1 stop bit.

**WAKE — Wakeup Bit**

This read/write bit selects the condition that wakes up the SCI receiver when it has been placed in a standby state by setting the RWU bit in SCICR2. When WAKE is set, a logic 1 (address mark) in the most significant bit position of a received data character wakes the receiver. An idle condition on the RXD pin does so when WAKE = 0. Reset clears WAKE.

- 1 = Address mark receiver wakeup
- 0 = Idle line receiver wakeup

**ILT — Idle Line Type Bit**

This read/write bit determines when the receiver starts counting logic 1s as idle character bits. The counting begins either after the start bit or after the stop bit. If the count begins after the start bit, then a string of logic 1s preceding the stop bit may cause false recognition of an idle character. Beginning the count after the stop bit avoids false idle character recognition, but requires properly synchronized transmissions. Reset clears ILT.

- 1 = Idle frame bit count begins after stop bit.
- 0 = Idle frame bit count begins after start bit.

**PE — Parity Enable Bit**

This read/write bit enables the parity function. When enabled, the parity function inserts a parity bit in the most significant bit position of an SCI data word. Reset clears PE.

- 1 = Parity function enabled
- 0 = Parity function disabled

**PT — Parity Type Bit**

This read/write bit selects even parity or odd parity. With even parity, an even number of 1s clears the parity bit and an odd number of 1s sets the parity bit. With odd parity, an odd number of 1s clears the parity bit and an even number of 1s sets the parity bit. Reset clears PT.

- 1 = Odd parity when PE = 1
- 0 = Even parity when PE = 1

**17.7.3 SCI Control Register 2**

Address: SCI1 — 0x00cc\_0003  
 SCI2 — 0x00cd\_0003

	Bit 7	6	5	4	3	2	1	Bit 0
Read:	TIE	TCIE	RIE	ILIE	TE	RE	RWU	SBK
Write:								
Reset:	0	0	0	0	0	0	0	0

**Figure 17-5. SCI Control Register 2 (SCICR2)**

Read: Anytime

Write: Anytime

**TIE** — Transmitter Interrupt Enable Bit

This read/write bit allows the TDRE flag to generate interrupt requests. Reset clears TIE.

- 1 = TDRE interrupt requests enabled
- 0 = TDRE interrupt requests disabled

**TCIE** — Transmission Complete Interrupt Enable Bit

This read/write bit allows the TC flag to generate interrupt requests. Reset clears TCIE.

- 1 = TC interrupt requests enabled
- 0 = TC interrupt requests disabled

**RIE** — Receiver Interrupt Enable Bit

This read/write bit allows the RDRF and OR flags to generate interrupt requests. Reset clears RIE.

- 1 = RDRF and OR interrupt requests enabled
- 0 = RDRF and OR interrupt requests disabled

**ILIE** — Idle Line Interrupt Enable Bit

This read/write bit allows the IDLE flag to generate interrupt requests. Reset clears ILIE.

- 1 = IDLE interrupt requests enabled
- 0 = IDLE interrupt requests disabled

## TE — Transmitter Enable Bit

This read/write bit enables the transmitter and configures the TXD pin as the transmitter output. Toggling TE queues an idle frame. Reset clears TE.

- 1 = Transmitter enabled
- 0 = Transmitter disabled

## RE — Receiver Enable Bit

This read/write bit enables the receiver. Reset clears RE.

- 1 = Receiver enabled
- 0 = Receiver disabled

**NOTE:** *When LOOPS = 0 and TE = RE = 1, the RXD pin is an input and the TXD pin is an output regardless of the state of the DDRSC1 (TXD) and DDRSC0 (RXD) bits.*

## RWU — Receiver Wakeup Bit

This read/write bit puts the receiver in a standby state that inhibits receiver interrupt requests. The WAKE bit determines whether an idle input or an address mark wakes up the receiver and clears RWU. Reset clears RWU.

- 1 = Receiver asleep when RE = 1
- 0 = Receiver awake when RE = 1

## SBK — Send Break Bit

Setting this read/write bit causes the SCI to send break frames of 10 (M = 0) or 11 (M = 1) logic 0s. To send one break frame, set SBK and then clear it before the break frame is finished transmitting. As long as SBK is set, the transmitter continues to send break frames.

- 1 = Transmitter sends break frames.
- 0 = Transmitter does not send break frames.

17.7.4 SCI Status Register 1

Address: SCI1 — 0x00cc\_0004  
 SCI2 — 0x00cd\_0004

	Bit 7	6	5	4	3	2	1	Bit 0
Read:	TDRE	TC	RDRF	IDLE	OR	NF	FE	PF
Write:								
Reset:	1	1	0	0	0	0	0	0

= Writes have no effect and the access terminates without a transfer error exception.

Figure 17-6. SCI Status Register 1 (SCISR1)

Read: Anytime

Write: Has no meaning or effect

TDRE — Transmit Data Register Empty Flag

The TDRE flag is set when the transmit shift register receives a word from the SCI Data Register. It signals that the SCIDRH and SCIDRL are empty and can receive new data to transmit. If the TIE bit in the SCICR2 is also set, TDRE generates an interrupt request. Clear TDRE by reading SCISR1 and then writing to SCIDRL. Reset sets TDRE.

- 1 = Transmit data register empty
- 0 = Transmit data register not empty

TC — Transmit Complete Flag

The TC flag is set when TDRE = 1 and no data, preamble, or break frame is being transmitted. It signals that no transmission is in progress. If the TCIE bit is set in SCICR2, TC generates an interrupt request. When TC is set, the TXD pin is idle (logic 1). TC is cleared automatically when a data, preamble, or break frame is queued. Clear TC by reading SCISR1 with TC set and then writing to SCIDRL. TC cannot be cleared while a transmission is in progress. Reset sets TC.

- 1 = No transmission in progress
- 0 = Transmission in progress

**RDRF — Receive Data Register Full Flag**

The RDRF flag is set when the data in the receive shift register is transferred to SCIDRH and SCIDRL. It signals that the received data is available to the MCU. If the RIE bit is set in SCICR2, RDRF generates an interrupt request. Clear RDRF by reading the SCISR1 and then reading SCIDRL. Reset clears RDRF.

- 1 = Received data available in SCIDRH and SCIDRL
- 0 = Received data not available in SCIDRH and SCIDRL

**IDLE — Idle Line Flag**

The IDLE flag is set when 10 (if M = 0) or 11 (if M = 1) consecutive logic 1s appear on the receiver input. If the ILIE bit in SCICR2 is set, IDLE generates an interrupt request. Once IDLE is cleared, a valid frame must again set the RDRF flag before an idle condition can set the IDLE flag. Clear IDLE by reading SCISR1 and then reading SCIDRL. Reset clears IDLE.

- 1 = Receiver idle
- 0 = Receiver active or idle since reset or idle since IDLE flag last cleared

**NOTE:** *When RWU of SCICR2 = 1, an idle line condition does not set the IDLE flag.*

**OR — Overrun Flag**

The OR flag is set if data is not read from SCIDRL before the receive shift register receives the stop bit of the next frame. This is a receiver overrun condition. If the RIE bit in SCICR2 is set, OR generates an interrupt request. The data in the shift register is lost, but the data already in the SCIDRH and SCIDRL is not affected. Clear OR by reading SCISR1 and then reading SCIDRL. Reset clears OR.

- 1 = Overrun
- 0 = No overrun

**NF — Noise Flag**

The NF flag is set when the SCI detects noise on the receiver input. NF is set during the same cycle as the RDRF flag but does not get set in the case of an overrun. Clear NF by reading SCISR1 and then reading SCIDRL. Reset clears NF.

- 1 = Noise
- 0 = No noise

**FE — Framing Error Flag**

The FE flag is set when a logic 0 is accepted as the stop bit. FE is set during the same cycle as the RDRF flag but does not get set in the case of an overrun. FE inhibits further data reception until it is cleared. Clear FE by reading SCISR1 and then reading SCIDRL. Reset clears FE.

- 1 = Framing error
- 0 = No framing error

**PF — Parity Error Flag**

The PF flag is set when PE = 1 and the parity of the received data does not match its parity bit. Clear PF by reading SCISR1 and then reading SCIDRL. Reset clears PF.

- 1 = Parity error
- 0 = No parity error



**17.7.5 SCI Status Register 2**

Address: SCI1 — 0x00cc\_0005  
SCI2 — 0x00cd\_0005

	Bit 7	6	5	4	3	2	1	Bit 0
Read:	0	0	0	0	0	0	0	RAF
Write:								
Reset:	0	0	0	0	0	0	0	0

= Writes have no effect and the access terminates without a transfer error exception.

**Figure 17-7. SCI Status Register 2 (SCISR2)**

Read: Anytime

Write: Has no meaning or effect

RAF — Receiver Active Flag

The RAF flag is set when the receiver detects a logic 0 during the RT1 time period of the start bit search. When the receiver detects an idle character, it clears RAF. Reset clears RAF.

1 = Reception in progress

0 = No reception in progress

17.7.6 SCI Data Registers

Address: SCI1 — 0x00cc\_0006  
 SCI2 — 0x00cd\_0006

	Bit 7	6	5	4	3	2	1	Bit 0
Read:	R8	T8	0	0	0	0	0	0
Write:								
Reset:	0	0	0	0	0	0	0	0

= Writes have no effect and the access terminates without a transfer error exception.

Figure 17-8. SCI Data Register High (SCIDRH)

Address: SCI1 — 0x00cc\_0007  
 SCI2 — 0x00cd\_0007

	Bit 7	6	5	4	3	2	1	Bit 0
Read:	R7	R6	R5	R4	R3	R2	R1	R0
Write:	T7	T6	T5	T4	T3	T2	T1	T0
Reset:	0	0	0	0	0	0	0	0

Figure 17-9. SCI Data Register Low (SCIDRL)

Read: Anytime

Write: Anytime; writing to R8 has no effect

R8 — Receive Bit 8

The R8 bit is the ninth received data bit when using the 9-bit data format (M = 1). Reset clears R8.

T8 — Transmit Bit 8

The T8 bit is the ninth transmitted data bit when using the 9-bit data format (M = 1). Reset clears T8.

R[7:0] — Receive Bits [7:0]

The R[7:0] bits are receive bits [7:0] when using the 9-bit or 8-bit data format. Reset clears R[7:0].

T[7:0] — Transmit Bits [7:0]

The T[7:0] bits are transmit bits [7:0] when using the 9-bit or 8-bit data format. Reset clears T[7:0].

**NOTE:** *If the value of T8 is the same as in the previous transmission, T8 does not have to be rewritten. The same value is transmitted until T8 is rewritten.*

*When using the 8-bit data format, only SCIDRL needs to be accessed.*

*When using 8-bit write instructions to transmit 9-bit data, write first to SCIDRH, then to SCIDRL.*

## 17.7.7 SCI Pullup and Reduced Drive Register

Address: SCI1 — 0x00cc\_0008  
SCI2 — 0x00cd\_0008

	Bit 7	6	5	4	3	2	1	Bit 0
Read:	SCISDOZ	0	RSVD5	RDPSCI	0	0	RSVD1	PUPSCI
Write:								
Reset:	0	0	0	0	0	0	0	0

 = Writes have no effect and the access terminates without a transfer error exception.

**Figure 17-10. SCI Pullup and Reduced Drive Register (SCIPURD)**

Write: Anytime

**SCISDOZ** — SCI Stop in Doze Mode Bit

The SCISDOZ bit disables the SCI in doze mode.

1 = SCI disabled in doze mode

0 = SCI enabled in doze mode

**RSVD[5:1]** — Reserved

Writing to these read/write bits updates their values but has no effect on functionality.

**RDPSCI** — Reduced Drive Bit

This read/write bit controls the drive capability of TXD and RXD.

1 = Reduced TXD and RXD pin drive

0 = Full TXD and RXD pin drive

PUPSCI — Pullup Enable Bit

This read/write bit enables the pullups on pins TXD and RXD. If a pin is programmed as an output, the pullup is disabled.

- 1 = TXD and RXD pullups enabled
- 0 = TXD and RXD pullups disabled

17.7.8 SCI Port Data Register

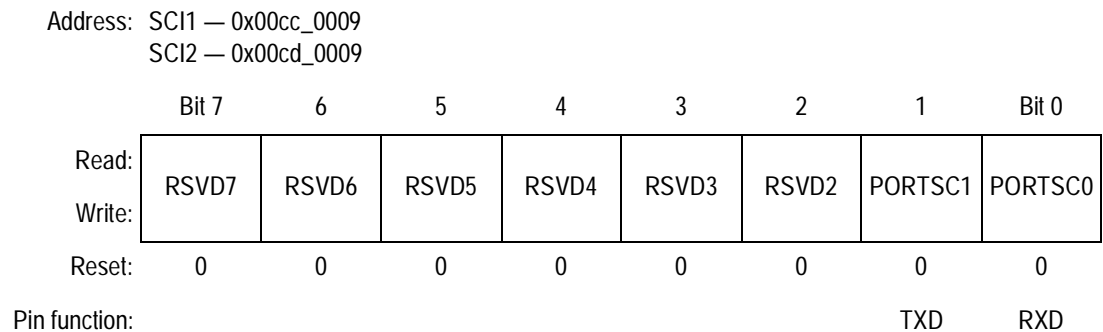

Figure 17-11. SCI Port Data Register (SCIPOINT)

Read: Anytime; when DDRSCx = 0, its pin is configured as an input, and reading PORTSCx returns the pin level; when DDRSCx = 1, its pin is configured as an output, and reading PORTSCx returns the pin driver output level.

Write: Anytime; data stored in internal latch drives pin only if DDRSC bit = 1

RSVD[7:2] — Reserved

Writing to these read/write bits updates their values but has no effect on functionality.

PORTSC[1:0] — SCIPOINT Data Bits

These are the read/write data bits of the SCI port.

**NOTE:** Writes to SCIPOINT do not change the pin state when the pin is configured for SCI input.

To ensure correct reading of the SCI pin values from SCIPOINT, always wait at least one cycle after writing to SCIDDR before reading SCIPOINT.

### 17.7.9 SCI Data Direction Register

Address: SCI1 — 0x00cc\_000a  
SCI2 — 0x00cd\_000a

	Bit 7	6	5	4	3	2	1	Bit 0
Read:	RSVD7	RSVD6	RSVD5	RSVD4	RSVD3	RSVD2	DDRSC1	DDRSC0
Write:								
Reset:	0	0	0	0	0	0	0	0

**Figure 17-12. SCI Data Direction Register (SCIDDR)**

Read: Anytime

Write: Anytime

RSVD[7:2] — Reserved

Writing to these read/write bits updates their values but has no effect on functionality.

DDRSC[1:0] — SCIPOINT Data Direction Bits

These bits control the data direction of the SCIPOINT pins. Reset clears DDRSC[1:0].

1 = Corresponding pin configured as output

0 = Corresponding pin configured as input

**NOTE:** When  $LOOPS = 0$  and  $TE = RE = 1$ , the RXD pin is an input and the TXD pin is an output regardless of the state of the DDRSC1 (TXD) and DDRSC0 (RXD) bits.

### 17.8 Functional Description

The SCI allows full-duplex, asynchronous, non-return-to-zero (NRZ) serial communication between the MCU and remote devices, including other MCUs. The SCI transmitter and receiver operate independently, although they use the same baud rate generator. The CPU monitors the status of the SCI, writes the data to be transmitted, and processes received data.

### 17.9 Data Format

The SCI uses the standard NRZ mark/space data format shown in [Figure 17-13](#).

Each frame has a start bit, eight or nine data bits, and one or two stop bits. Clearing the M bit in SCCR1 configures the SCI for 10-bit frames. Setting the M bit configures the SCI for 11-bit frames.

When the SCI is configured for 9-bit data, the ninth data bit is the T8 bit in SCI Data Register high (SCIDRH). It remains unchanged after transmission and can be used repeatedly without rewriting it. A frame with nine data bits has a total of 11 bits.

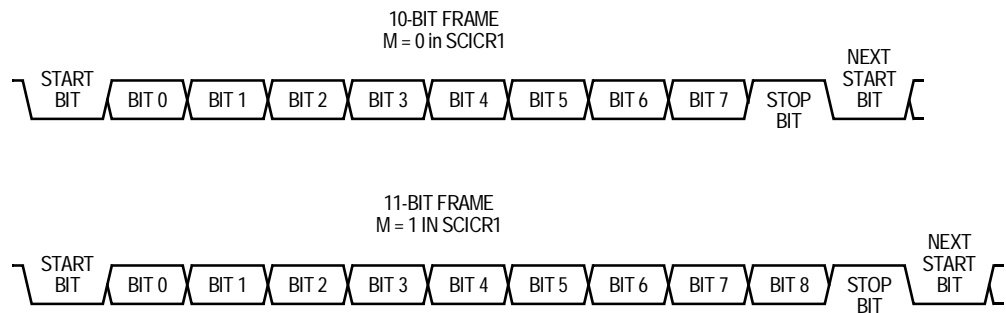

Figure 17-13. SCI Data Formats

## 17.10 Baud Rate Generation

A 13-bit modulus counter in the baud rate generator derives the baud rate for both the receiver and the transmitter. The value from 0 to 8191 written to SCIBDH and SCIBDL determines the system clock divisor. The baud rate clock is synchronized with the bus clock and drives the receiver. The baud rate clock divided by 16 drives the transmitter. The receiver acquisition rate is 16 samples per bit time.

Baud rate generation is subject to two sources of error:

1. Integer division of the module clock may not give the exact target frequency.
2. Synchronization with the bus clock can cause phase shift.

**Table 17-4. Example Baud Rates  
(System Clock = 33 MHz)**

SBR[12:0]	Receiver Clock (Hz)	Transmitter Clock (Hz)	Target Baud Rate	Percent Error
0x0012	1,833,333.3	114,583.3	115,200	0.54
0x0024	916,666.7	57,291.7	57,600	0.54
0x0036	611,111.1	38,194.4	38,400	0.54
0x003d	540,983.6	33,811.4	33,600	0.63
0x0048	458,333.3	28,645.8	28,800	0.54
0x006b	308,411.2	19,275.7	19,200	0.39
0x0008f	230,769.2	14,423.1	14,400	0.16
0x00d7	153,488.4	9,593.0	9,600	0.07
0x01ae	76,744.2	4,796.5	4,800	0.07
0x035b	38,416.8	2,401.0	2,400	0.04
0x06b7	19,197.2	1,199.8	1,200	0.01
0x0d6d	9,601.4	600.1	600	0.01
0x1adb	4,800.0	300.0	300	0

17.11 Transmitter

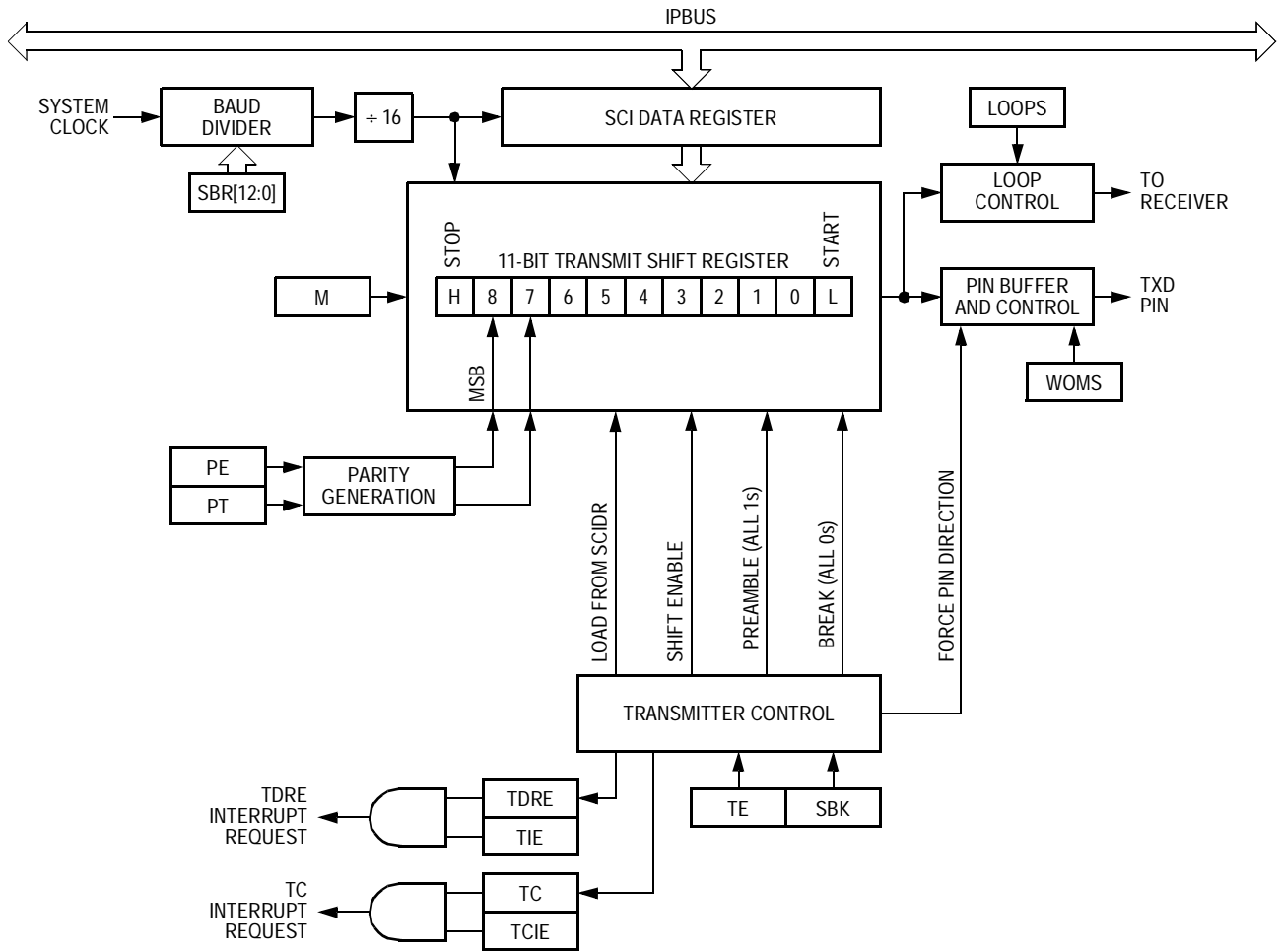

Figure 17-14. Transmitter Block Diagram

Freescale Semiconductor, Inc.



### 17.11.1 Frame Length

The transmitter can generate either 10-bit or 11-bit frames. In SCICR1, the M bit selects frame length, and the PE bit enables the parity function. One data bit may be an address mark or an extra stop bit. All frames begin with a start bit and end with one or two stop bits. When transmitting 9-bit data, bit T8 in SCI Data Register high (SCIDRH) is the ninth bit (bit 8).

**Table 17-5. Example 10-Bit and 11-Bit Frames**

M Bit	Frame Length	Start Bit	Data Bits	Parity Bit	Address Mark <sup>(1)</sup>	Stop Bit(s)
0	10 bits	1	8	No	No	1
		1	7	No	No	2
		1	7	No	Yes	1
		1	7	Yes	No	1
1	11 bits	1	9	No	No	1
		1	8	No	No	2
		1	8	No	Yes	1
		1	8	Yes	No	1
		1	7	No	Yes	2
		1	7	Yes	No	2

1. When implementing a multidrop network using the SCI, the address mark bit is used to designate subsequent data frames as a network address and not device data.

### 17.11.2 Transmitting a Frame

To begin an SCI transmission:

1. Configure the SCI:
  - a. Write a baud rate value to SCIBDH and SCIBDL.
  - b. Write to SCICR1 to:
    - i. Enable or disable loop mode and select the receiver feedback path
    - ii. Select open-drain or wired-OR SCI outputs
    - iii. Select 10-bit or 11-bit frames
    - iv. Select the receiver wakeup condition: address mark or idle line
    - v. Select idle line type
    - vi. Enable or disable the parity function and select odd or even parity
  - c. Write to SCICR2 to:
    - i. Enable or disable TDRE, TC, RDRF, and IDLE interrupt requests
    - ii. Enable the transmitter and queue a break frame
    - iii. Enable or disable the receiver
    - iv. Put the receiver in standby if required
2. Transmit a byte:
  - a. Clear the TDRE flag by reading SCISR1 and, if sending 9-bit data, write the ninth data bit to SCDRH.
  - b. Write the byte to be transmitted (or low-order 8 bits if sending 9-bit data) to SCIDRL.
3. Repeat step 2 for each subsequent transmission.

Writing the TE bit from 0 to 1 loads the transmit shift register with a preamble of 10 (if  $M = 0$ ) or 11 (if  $M = 1$ ) logic 1s. When the preamble shifts out, the SCI transfers the data from SCIDRH and SCIDRL to the transmit shift register. The transmit shift register prefaces the data with a 0 start bit and appends the data with a 1 stop bit and begins shifting out the frame.

The SCI sets the TDRE flag every time it transfers data from SCIDRH and SCIDRL to the transmit shift register. TDRE indicates that SCIDRH

and SCIDRL can accept new data. If the TIE bit is set, TDRE generates an interrupt request.

**NOTE:** *SCIDRH and SCIDRL transfer data to the transmit shift register and sets TDRE 9/16ths of a bit time after the previous frame's stop bit starts to shift out.*

Hardware supports odd or even parity. When parity is enabled, the most significant data bit is the parity bit.

When the transmit shift register is not transmitting a frame, the TXD pin goes to the idle condition, logic 1. Clearing the TE bit while the transmitter is idle will return control of the TXD pin to the SCI data direction (SCIDDR) and SCI port (SCIPORT) registers.

If the TE bit is cleared while a transmission is in progress (while TC = 0), the frame in the transmit shift register continues to shift out. Then the TXD pin reverts to being a general-purpose I/O pin even if there is data pending in the SCI Data Register. To avoid accidentally cutting off a message, always wait until TDRE is set after the last frame before clearing TE.

To separate messages with preambles with minimum idle line time, use this sequence between messages:

1. Write the last byte of the first message to SCIDRH and SCIDRL.
2. Wait until the TDRE flag is set, indicating the transfer of the last frame to the transmit shift register.
3. Queue a preamble by clearing and then setting the TE bit.
4. Write the first byte of the second message to SCIDRH and SCIDRL.

When the SCI relinquishes the TXD pin, the SCIPORT and SCIDDR registers control the TXD pin.

To force TXD high when turning off the transmitter, set bit 1 of the SCI Port Register (SCIPORT) and bit 1 of the SCI Data Direction Register (SCIDDR). The TXD pin goes high as soon as the SCI relinquishes control of it. See [17.7.8 SCI Port Data Register](#) and [17.7.9 SCI Data Direction Register](#).

### 17.11.3 Break Frames

Setting the SBK bit in SCICR2 loads the transmit shift register with a break frame. A break frame contains all logic 0s and has no start, stop, or parity bit. Break frame length depends on the M bit in the SCICR1 register. As long as SBK is set, the SCI continuously loads break frames into the transmit shift register. After SBK is clear, the transmit shift register finishes transmitting the last break frame and then transmits at least one logic 1. The automatic logic 1 at the end of a break frame guarantees the recognition of the next start bit.

The SCI recognizes a break frame when a start bit is followed by eight or nine 0 data bits and a 0 where the stop bit should be. Receiving a break frame has these effects on SCI registers:

- Sets the FE flag
- Sets the RDRF flag
- Clears the SCIDRH and SCIDRL
- May set the OR flag, NF flag, PE flag, or the RAF flag

### 17.11.4 Idle Frames

An idle frame contains all logic 1s and has no start, stop, or parity bit. Idle frame length depends on the M bit in the SCICR1 register. The preamble is a synchronizing idle frame that begins the first transmission after writing the TE bit from 0 to 1.

If the TE bit is cleared during a transmission, the TXD pin becomes idle after completion of the transmission in progress. Clearing and then setting the TE bit during a transmission queues an idle frame to be sent after the frame currently being transmitted.

**NOTE:** *When queueing an idle frame, return the TE bit to logic 1 before the stop bit of the current frame shifts out to the TXD pin. Setting TE after the stop bit appears on TXD causes data previously written to SCIDRH and SCIDRL to be lost. Toggle TE to queue an idle frame, while the TDRE flag is set, immediately before writing new data to SCIDRH and SCIDRL.*

## 17.12 Receiver

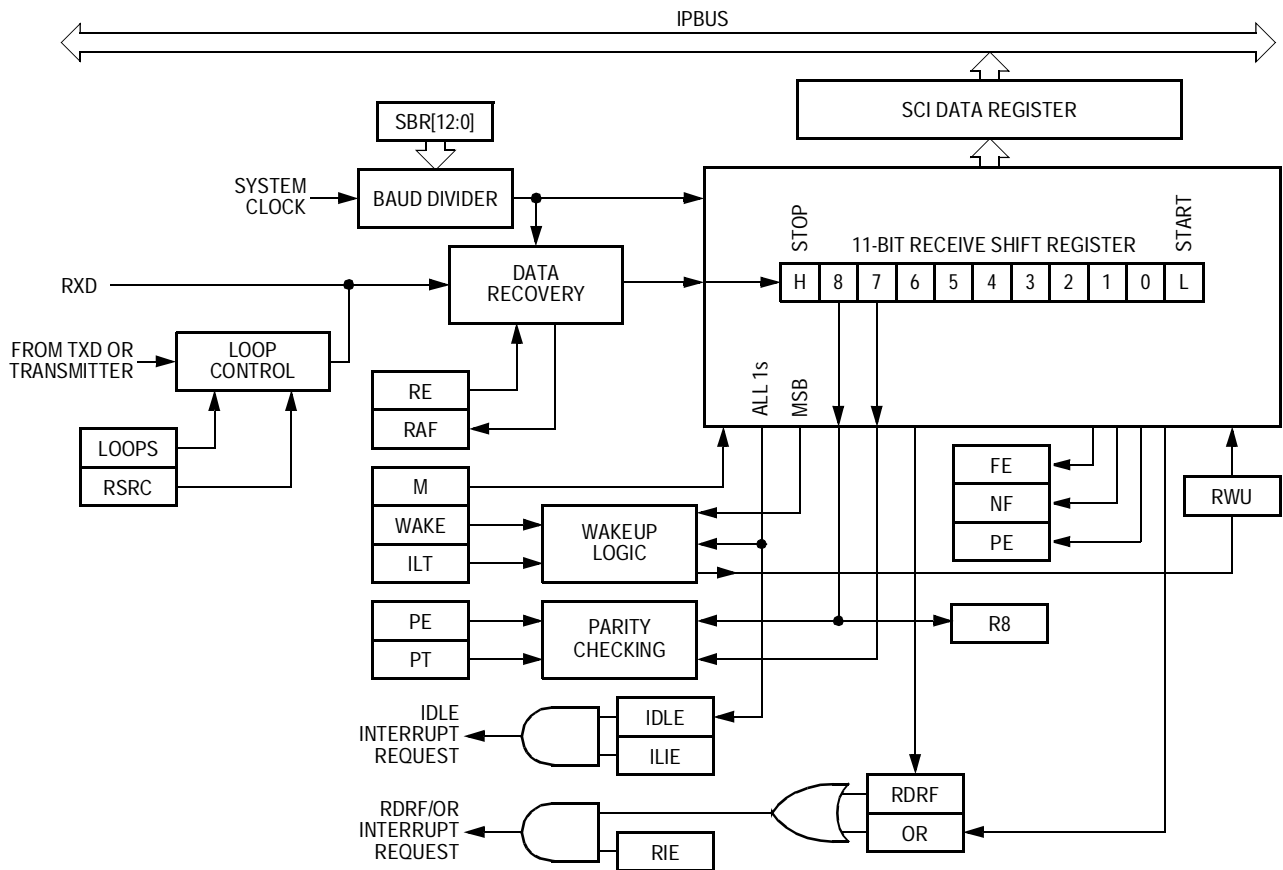

**Figure 17-15. SCI Receiver Block Diagram**

### 17.12.1 Frame Length

The receiver can handle either 8-bit or 9-bit data. The state of the M bit in SCICR1 selects frame length. When receiving 9-bit data, bit R8 in SCIDRH is the ninth bit (bit 8).

### 17.12.2 Receiving a Frame

When the SCI receives a frame, the receive shift register shifts the frame in from the RXD pin.

After an entire frame shifts into the receive shift register, the data portion of the frame transfers to SCIDRH and SCIDRL. The RDRF flag is set, indicating that the received data can be read. If the RIE bit is also set, RDRF generates an interrupt request.

### 17.12.3 Data Sampling

The receiver samples the RXD pin at the RT clock rate. The RT clock is an internal signal with a frequency 16 times the baud rate. To adjust for baud rate mismatch, the RT clock resynchronizes:

- After every start bit
- After the receiver detects a data bit change from logic 1 to logic 0 (after the majority of data bit samples at RT8, RT9, and RT10 returns a valid logic 1 and the majority of the next RT8, RT9, and RT10 samples returns a valid logic 0)

To locate the start bit, data recovery logic does an asynchronous search for a 0 preceded by three 1s. When the falling edge of a possible start bit occurs, the RT clock begins to count to 16.

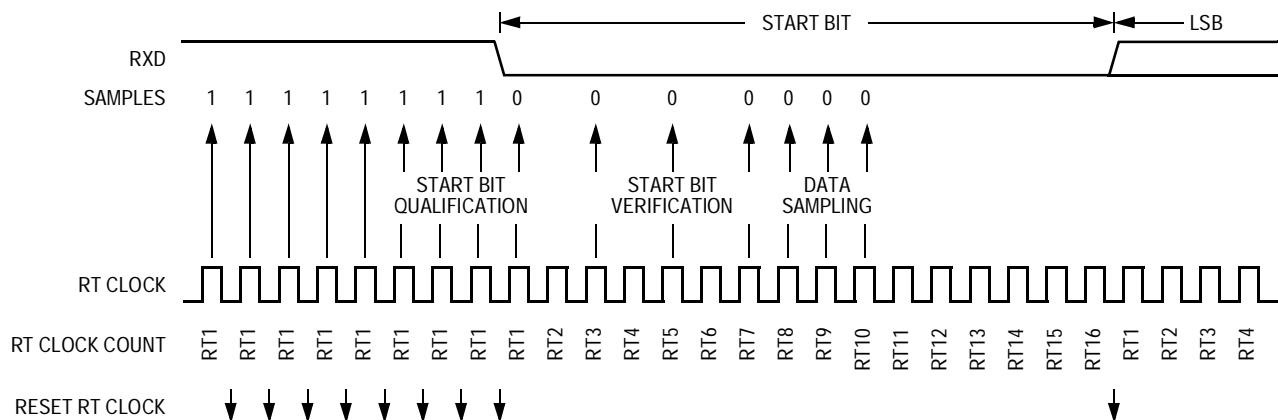

Figure 17-16. Receiver Data Sampling

To verify the start bit and to detect noise, data recovery logic takes samples at RT3, RT5, and RT7.

**Table 17-6. Start Bit Verification**

RT3, RT5, and RT7 Samples	Start Bit Verification	Noise Flag
000	Yes	0
001	Yes	1
010	Yes	1
011	No	0
100	Yes	1
101	No	0
110	No	0
111	No	0

If start bit verification is not successful, the RT clock is reset and a new search for a start bit begins.

To determine the value of a data bit and to detect noise, recovery logic takes samples at RT8, RT9, and RT10.

**Table 17-7. Data Bit Recovery**

RT8, RT9, and RT10 Samples	Data Bit Determination	Noise Flag
000	0	0
001	0	1
010	0	1
011	1	1
100	0	1
101	1	1
110	1	1
111	1	0

**NOTE:** *The RT8, RT9, and RT10 data samples do not affect start bit verification. If any or all of the RT8, RT9, and RT10 samples are logic 1s following a successful start bit verification, the NF flag is set and the receiver interprets the bit as a start bit (logic 0).*

The RT8, RT9, and RT10 samples also verify stop bits.

Table 17-8. Stop Bit Recovery

RT8, RT9, and RT10 Samples	Framing Error Flag	Noise Flag
000	1	0
001	1	1
010	1	1
011	0	1
100	1	1
101	0	1
110	0	1
111	0	0

In Figure 17-17, the verification samples RT3 and RT5 determine that the first low detected was noise and not the beginning of a start bit. The RT clock is reset and the start bit search begins again. The NF flag is not set because the noise occurred before the start bit was verified.

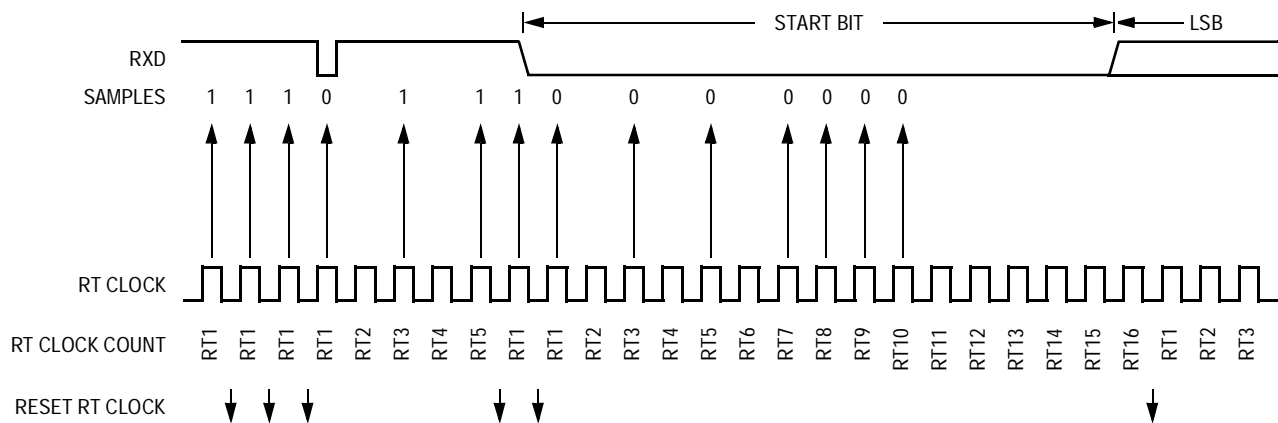
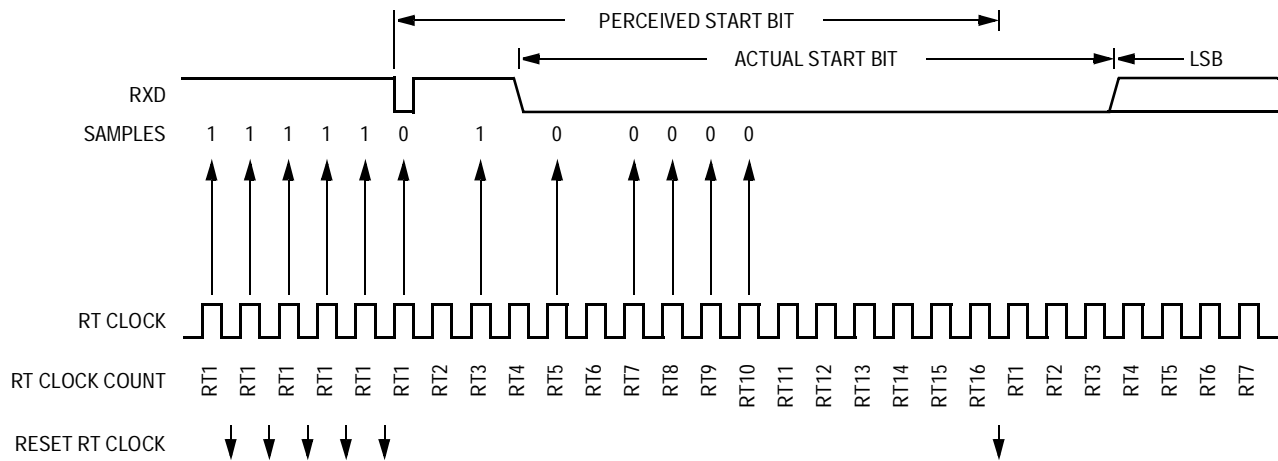

Figure 17-17. Start Bit Search Example 1



In **Figure 17-18**, noise is perceived as the beginning of a start bit although the RT3 sample is high. The RT3 sample sets the noise flag. Although the perceived bit time is misaligned, the RT8, RT9, and RT10 data samples are within the bit time, and data recovery is successful.



**Figure 17-18. Start Bit Search Example 2**

In **Figure 17-19** a large burst of noise is perceived as the beginning of a start bit, although the RT5 sample is high. The RT5 sample sets the noise flag. Although this is a worst-case misalignment of perceived bit time, the data samples RT8, RT9, and RT10 are within the bit time and data recovery is successful.

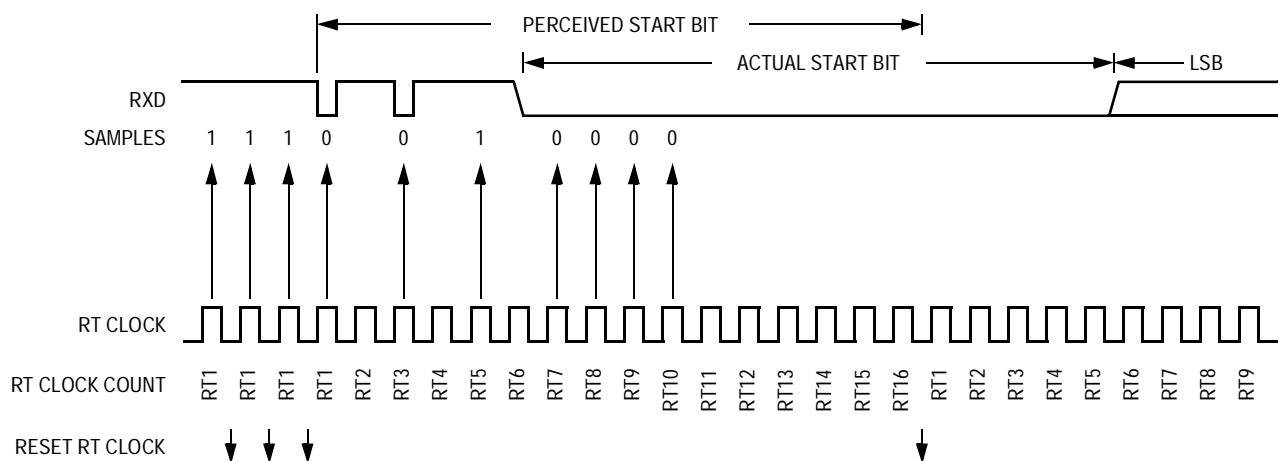

**Figure 17-19. Start Bit Search Example 3**

Figure 17-20 shows the effect of noise early in the start bit time. Although this noise does not affect proper synchronization with the start bit time, it does set the noise flag.

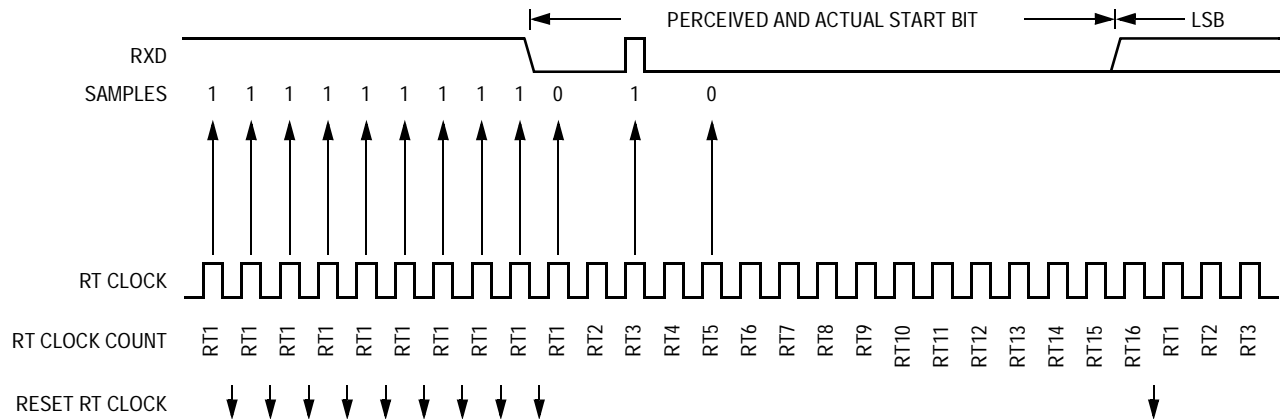

Figure 17-20. Start Bit Search Example 4

Figure 17-21 shows a burst of noise near the beginning of the start bit that resets the RT clock. The sample after the reset is low but is not preceded by three high samples that would qualify as a falling edge. Depending on the timing of the start bit search and on the data, the frame may be missed entirely or it may set the framing error flag.

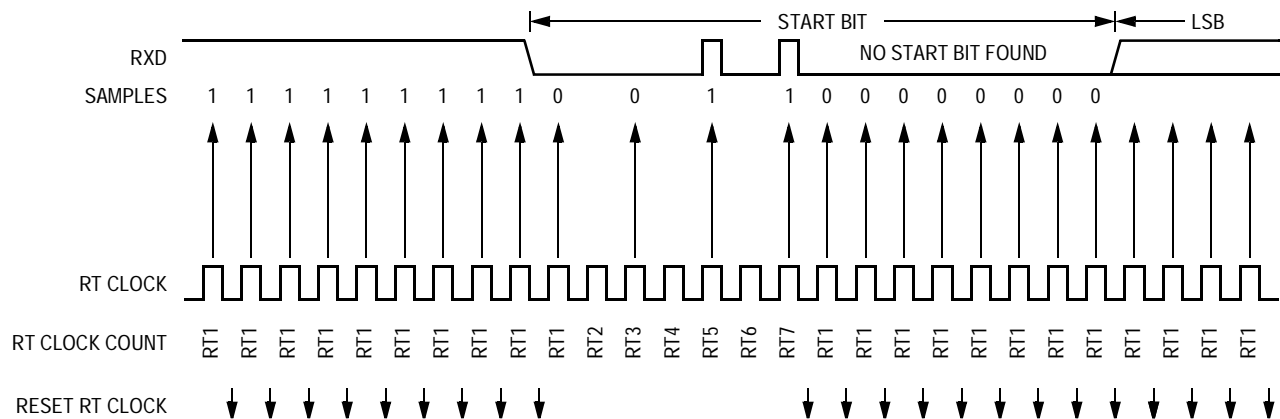
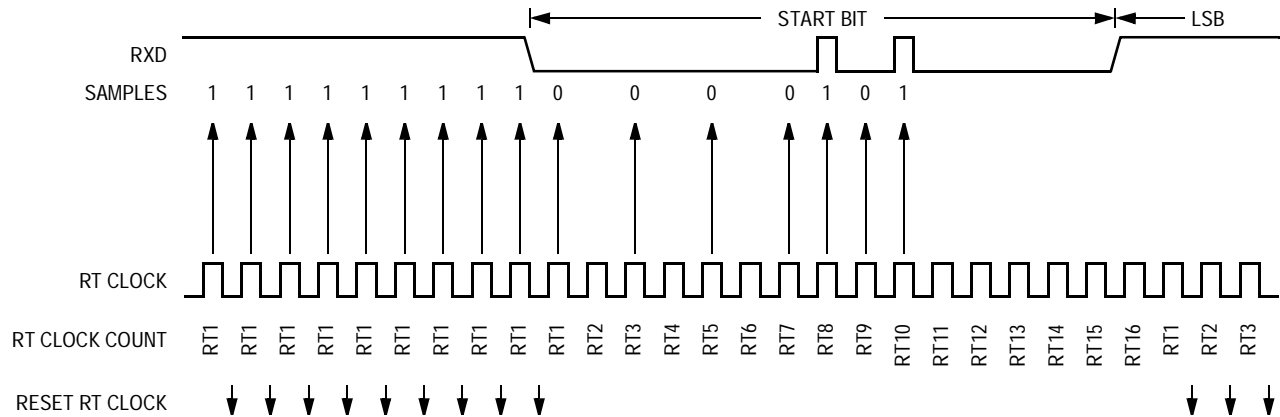

Figure 17-21. Start Bit Search Example 5

In **Figure 17-22** a noise burst makes the majority of data samples RT8, RT9, and RT10 high. This sets the noise flag but does not reset the RT clock. In start bits only, the RT8, RT9, and RT10 data samples are ignored.



**Figure 17-22. Start Bit Search Example 6**

### 17.12.4 Framing Errors

If the data recovery logic does not detect a 1 where the stop bit should be in an incoming frame, it sets the FE flag in SCISR1. A break frame also sets the FE flag because a break frame has no stop bit. The FE flag is set at the same time that the RDRF flag is set.

### 17.12.5 Baud Rate Tolerance

A transmitting device may be operating at a baud rate below or above the receiver baud rate. Accumulated bit time misalignment can cause one of the RT8, RT9, and RT10 stop bit data samples to fall outside the stop bit. A noise error occurs if the samples are not all the same value. If more than one of the samples is outside the stop bit, a framing error occurs. In most applications, the baud rate tolerance is much more than the degree of misalignment that is likely to occur.

As the receiver samples an incoming frame, it resynchronizes the RT clock on any valid falling edge within the frame. Resynchronization within frames corrects misalignments between transmitter bit times and receiver bit times.

17.12.5.1 Slow Data Tolerance

Figure 17-23 shows how much a slow received frame can be misaligned without causing a noise error or a framing error. The slow stop bit begins at RT8 instead of RT1 but arrives in time for the stop bit data samples at RT8, RT9, and RT10.

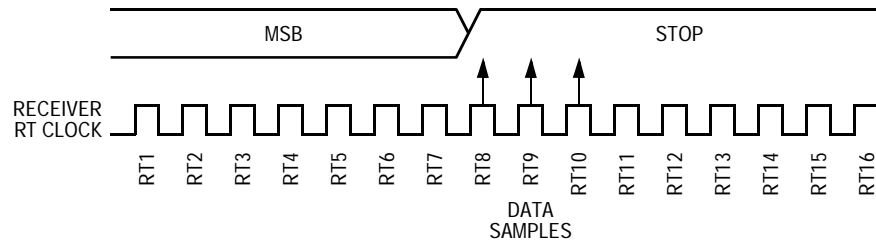

Figure 17-23. Slow Data

For 8-bit data, sampling of the stop bit takes the receiver:

$$9 \text{ bit times} \times 16 \text{ RT cycles} + 10 \text{ RT cycles} = 154 \text{ RT cycles.}$$

With the misaligned data shown in Figure 17-23, the receiver counts 154 RT cycles at the point when the count of the transmitting device is:

$$9 \text{ bit times} \times 16 \text{ RT cycles} + 3 \text{ RT cycles} = 147 \text{ RT cycles.}$$

The maximum percent difference between the receiver count and the transmitter count for slow 8-bit data with no errors is:

$$\left| \frac{154 - 147}{154} \right| \times 100 = 4.54\%$$

For 9-bit data, sampling of the stop bit takes the receiver:

$$10 \text{ bit times} \times 16 \text{ RT cycles} + 10 \text{ RT cycles} = 170 \text{ RT cycles.}$$

With the misaligned data shown in Figure 17-23, the receiver counts 170 RT cycles at the point when the count of the transmitting device is:

$$10 \text{ bit times} \times 16 \text{ RT cycles} + 3 \text{ RT cycles} = 163 \text{ RT cycles.}$$

The maximum percent difference between the receiver count and the transmitter count for slow 9-bit data with no errors is:

$$\left| \frac{170 - 163}{170} \right| \times 100 = 4.12\%$$

17.12.5.2 Fast Data Tolerance

**Figure 17-24** shows how much a fast received frame can be misaligned without causing a noise error or a framing error. The fast stop bit ends at RT10 instead of RT16 but is still sampled at RT8, RT9, and RT10.

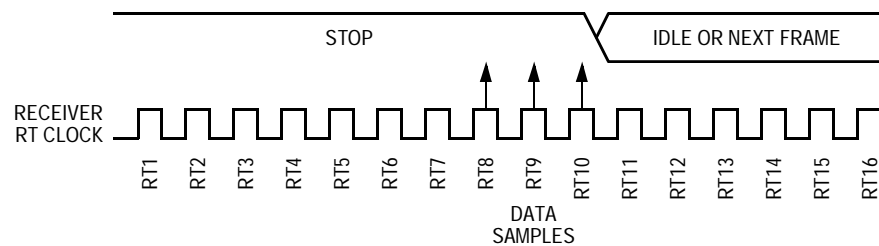

**Figure 17-24. Fast Data**

For 8-bit data, sampling of the stop bit takes the receiver:

$$9 \text{ bit times} \times 16 \text{ RT cycles} + 10 \text{ RT cycles} = 154 \text{ RT cycles.}$$

With the misaligned data shown in **Figure 17-24**, the receiver counts 154 RT cycles at the point when the count of the transmitting device is:

$$10 \text{ bit times} \times 16 \text{ RT cycles} = 160 \text{ RT cycles.}$$

The maximum percent difference between the receiver count and the transmitter count for fast 8-bit data with no errors is:

$$\left| \frac{154 - 160}{154} \right| \times 100 = 3.90\%$$

For 9-bit data, sampling of the stop bit takes the receiver:

$$10 \text{ bit times} \times 16 \text{ RT cycles} + 10 \text{ RT cycles} = 170 \text{ RT cycles.}$$

With the misaligned data shown in **Figure 17-24**, the receiver counts 170 RT cycles at the point when the count of the transmitting device is:

$$11 \text{ bit times} \times 16 \text{ RT cycles} = 176 \text{ RT cycles.}$$

The maximum percent difference between the receiver count and the transmitter count for fast 9-bit data with no errors is:

$$\left| \frac{170 - 176}{170} \right| \times 100 = 3.53\%$$

### 17.12.6 Receiver Wakeup

So that the SCI can ignore transmissions intended only for other devices in multiple-receiver systems, the receiver can be put into a standby state. Setting the RWU bit in SCICR2 puts the receiver into a standby state during which receiver interrupts are disabled.

The transmitting device can address messages to selected receivers by including addressing information in the initial frame or frames of each message.

The WAKE bit in SCICR1 determines how the SCI is brought out of the standby state to process an incoming message. The WAKE bit enables either idle line wakeup or address mark wakeup.

#### 17.12.6.1 Idle Input Line Wakeup (WAKE = 0)

When WAKE = 0, an idle condition on the RXD pin clears the RWU bit and wakes up the receiver. The initial frame or frames of every message contain addressing information. All receivers evaluate the addressing information, and receivers for which the message is addressed process the frames that follow. Any receiver for which a message is not addressed can set its RWU bit and return to the standby state. The RWU bit remains set and the receiver remains on standby until another idle frame appears on the RXD pin.

Idle line wakeup requires that messages be separated by at least one idle frame and that no message contains idle frames.

The idle frame that wakes up the receiver does not set the IDLE flag or the RDRF flag.

The ILT bit in SCICR1 determines whether the receiver begins counting logic 1s as idle frame bits after the start bit or after the stop bit.

### 17.12.6.2 Address Mark Wakeup (WAKE = 1)

When WAKE = 1, an address mark clears the RWU bit and wakes up the receiver. An address mark is a 1 in the most significant data bit position. The receiver interprets the data as address data. When using address mark wakeup, the MSB of all non-address data must be 0. User code must compare the address data to the receiver's address and, if the addresses match, the receiver processes the frames that follow. If the addresses do not match, user code must put the receiver back to sleep by setting the RWU bit. The RWU bit remains set and the receiver remains on standby until another address frame appears on the RXD pin.

The address mark clears the RWU bit before the stop bit is received and sets the RDRF flag.

Address mark wakeup allows messages to contain idle frames but requires that the most significant byte (MSB) be reserved for address data.

**NOTE:** *With the WAKE bit clear, setting the RWU bit after the RXD pin has been idle can cause the receiver to wake up immediately.*

### 17.13 Single-Wire Operation

Normally, the SCI uses the TXD pin for transmitting and the RXD pin for receiving (LOOPS = 0, RSRC = X). In single-wire mode, the RXD pin is disconnected from the SCI and is available as a general-purpose I/O pin. The SCI uses the TXD pin for both receiving and transmitting.

In single-wire mode (LOOPS = 1, RXRC = 1), setting the data direction bit for the TXD pin configures TXD as the output for transmitted data. Clearing the data direction bit configures TXD as the input for received data.

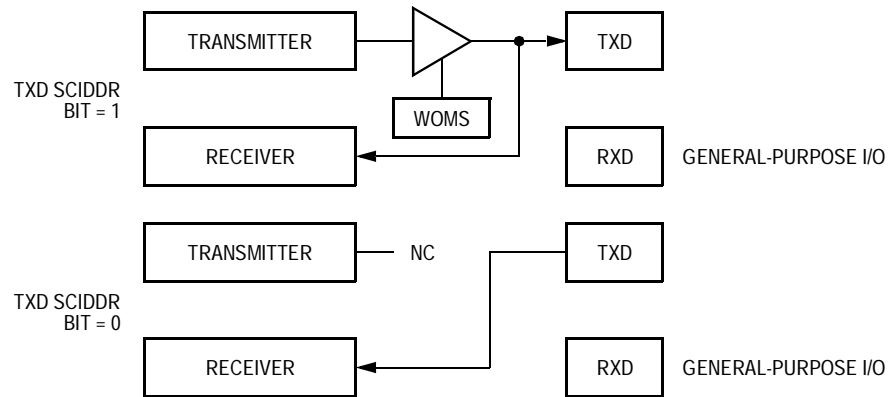

Figure 17-25. Single-Wire Operation (LOOPS = 1, RSRC = 1)

Enable single-wire operation by setting the LOOPS bit and the RSRC bit in SCICR1. Setting the LOOPS bit disables the path from the RXD pin to the receiver. Setting the RSRC bit connects the receiver input to the output of the TXD pin driver. Both the transmitter and receiver must be enabled (TE = 1 and RE = 1).

The WOMS bit in the SCICR1 register configures the TXD pin for full CMOS drive or for open-drain drive. WOMS controls the TXD pin in both normal operation and in single-wire operation. When WOMS is set, the DDR bit for the TXD pin does not have to be cleared for transmitter to receive data.



### 17.14 Loop Operation

In loop mode (LOOPS = 1, RSRC = 0), the transmitter output goes to the receiver input. The RXD pin is disconnected from the SCI and is available as a general-purpose I/O pin.

Setting the DDR bit for the TXD pin connects the transmitter output to the TXD pin. Clearing the data direction bit disconnects the transmitter output from the TXD pin.

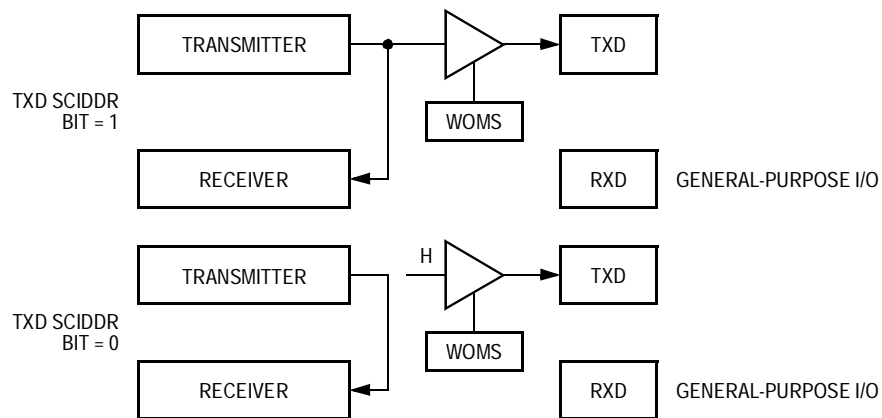

**Figure 17-26. Loop Operation (LOOPS = 1, RSRC = 0)**

Enable loop operation by setting the LOOPS bit and clearing the RSRC bit in SCICR1. Setting the LOOPS bit disables the path from the RXD pin to the receiver. Clearing the RSRC bit connects the transmitter output to the receiver input. Both the transmitter and receiver must be enabled (TE = 1 and RE = 1).

The WOMS bit in SCICR1 configures the TXD pin for full CMOS drive or for open-drain drive. WOMS controls the TXD pin during both normal operation and loop operation.

### 17.15 I/O Ports

The SCIPORT register is associated with two pins:

- The TXD pin is connected to SCIPORT1.
- The RXD pin is connected to SCIPORT0.

The SCI Data Direction Register (SCIDDR) configures the pins as inputs or outputs (see [17.7.9 SCI Data Direction Register](#)). The SCI Pullup and Reduced Drive Register (SCIPURD) controls pin drive capability and enables or disables pullups (see [17.7.7 SCI Pullup and Reduced Drive Register](#)). The WOMS bit in SCI Control Register 1 (SCICR1) configures output ports as full CMOS drive outputs or as open-drain outputs (see [17.7.2 SCI Control Register 1](#)).

**Table 17-9. SCI Port Control Summary**

Pullup Enable Control			Reduced Drive Control			Wired-OR Mode Control		
Register	Bit	Reset State	Register	Bit	Reset State	Register	Bit	Reset State
SCIPURD	PUPSCI	0	SCIPURD	RDPSCI	0	SCICR1	WOMS	CMOS drive

## 17.16 Reset

Reset initializes the SCI registers to a known startup state as described in [17.7 Memory Map and Registers](#).

## 17.17 Interrupts

**Table 17-10** lists the five interrupt requests associated with each SCI module.

**Table 17-10. SCI Interrupt Request Sources**

Source	Flag	Enable Bit
Transmitter	TDRE	TIE
	TC	TCIE
Receiver	RDRF	RIE
	OR	RIE
	IDLE	ILIE

### 17.17.1 Transmit Data Register Empty

The TDRE flag is set when the transmit shift register receives a byte from the SCI Data Register. It signals that SCIDRH and SCIDRL are empty and can receive new data to transmit. If the TIE bit in SCICR2 is also set, TDRE generates an interrupt request. Clear TDRE by reading SCISR1 and then writing to SCIDRL. Reset sets TDRE.

### 17.17.2 Transmission Complete

The TC flag is set when TDRE = 1 and no data, preamble, or break frame is being transmitted. It signals that no transmission is in progress. If the TCIE bit is set in SCICR2, TC generates an interrupt request. When TC is set, the TXD pin is idle (logic 1). TC is cleared automatically when a data, preamble, or break frame is queued. Clear TC by reading SCISR1 with TC set and then writing to the SCIDRL register. TC cannot be cleared while a transmission is in progress.

### 17.17.3 Receive Data Register Full

The RDRF flag is set when the data in the receive shift register transfers to SCIDRH and SCIDRL. It signals that the received data is available to be read. If the RIE bit is set in SCICR2, RDRF generates an interrupt request. Clear RDRF by reading SCISR1 and then reading SCIDRL.

### 17.17.4 Idle Receiver Input

The IDLE flag is set when 10 (if M = 0) or 11 (if M = 1) consecutive logic 1s appear on the receiver input. This signals an idle condition on the receiver input. If the ILIE bit in SCICR2 is set, IDLE generates an interrupt request. Once IDLE is cleared, a valid frame must again set the RDRF flag before an idle condition can set the IDLE flag. Clear IDLE by reading SCISR1 with IDLE set and then reading SCIDRL.

### 17.17.5 Overrun

The OR flag is set if data is not read from SCIDRL before the receive shift register receives the stop bit of the next frame. This signals a receiver overrun condition. If the RIE bit in SCICR2 is set, OR generates an interrupt request. The data in the shift register is lost, but the data already in SCIDRH and SCIDRL is not affected. Clear OR by reading SCISR1 and then reading SCIDRL.

## Section 18. Serial Peripheral Interface Module (SPI)

### 18.1 Contents

18.2	Introduction . . . . .	398
18.3	Features . . . . .	398
18.4	Modes of Operation . . . . .	399
18.5	Block Diagram . . . . .	399
18.6	Signal Description . . . . .	400
18.6.1	MISO (Master In/Slave Out) . . . . .	400
18.6.2	MOSI (Master Out/Slave In) . . . . .	400
18.6.3	SCK (Serial Clock) . . . . .	401
18.6.4	SS (Slave Select) . . . . .	401
18.7	Memory Map and Registers . . . . .	401
18.7.1	SPI Control Register 1 . . . . .	402
18.7.2	SPI Control Register 2 . . . . .	405
18.7.3	SPI Baud Rate Register . . . . .	406
18.7.4	SPI Status Register . . . . .	408
18.7.5	SPI Data Register . . . . .	409
18.7.6	SPI Pullup and Reduced Drive Register . . . . .	410
18.7.7	SPI Port Data Register . . . . .	411
18.7.8	SPI Port Data Direction Register . . . . .	412
18.8	Functional Description . . . . .	413
18.8.1	Master Mode . . . . .	414
18.8.2	Slave Mode . . . . .	415
18.8.3	Transmission Formats . . . . .	416
18.8.3.1	Transfer Format When CPHA = 1 . . . . .	416
18.8.3.2	Transfer Format When CPHA = 0 . . . . .	417
18.8.4	SPI Baud Rate Generation . . . . .	420
18.8.5	Slave-Select Output . . . . .	420
18.8.6	Bidirectional Mode . . . . .	421

18.8.7 Error Conditions .....422

18.8.7.1 Write Collision Error .....422

18.8.7.2 Mode Fault Error .....422

18.8.8 Low-Power Mode Options .....423

18.8.8.1 Run Mode .....423

18.8.8.2 Doze Mode.....423

18.8.8.3 Stop Mode .....424

18.9 Reset .....424

18.10 Interrupts.....424

18.10.1 Mode Fault (MODF) Flag .....424

18.10.2 SPI Interrupt Flag (SPIF) .....424

**18.2 Introduction**

The serial peripheral interface (SPI) module allows full-duplex, synchronous, serial communication between the microcontroller unit (MCU) and peripheral devices. Software can poll the SPI status flags or SPI operation can be interrupt driven.

**18.3 Features**

Features include:

- Master mode and slave mode
- Wired-OR mode
- Slave-select output
- Mode fault error flag with central processor unit (CPU) interrupt capability
- Double-buffered operation
- Serial clock with programmable polarity and phase
- Control of SPI operation during doze mode
- Reduced drive control for lower power consumption

## 18.4 Modes of Operation

The SPI functions in these three modes:

1. Run mode — Run mode is the normal mode of operation.
2. Doze mode — Doze mode is a configurable low-power mode.
3. Stop mode — The SPI is inactive in stop mode.

## 18.5 Block Diagram

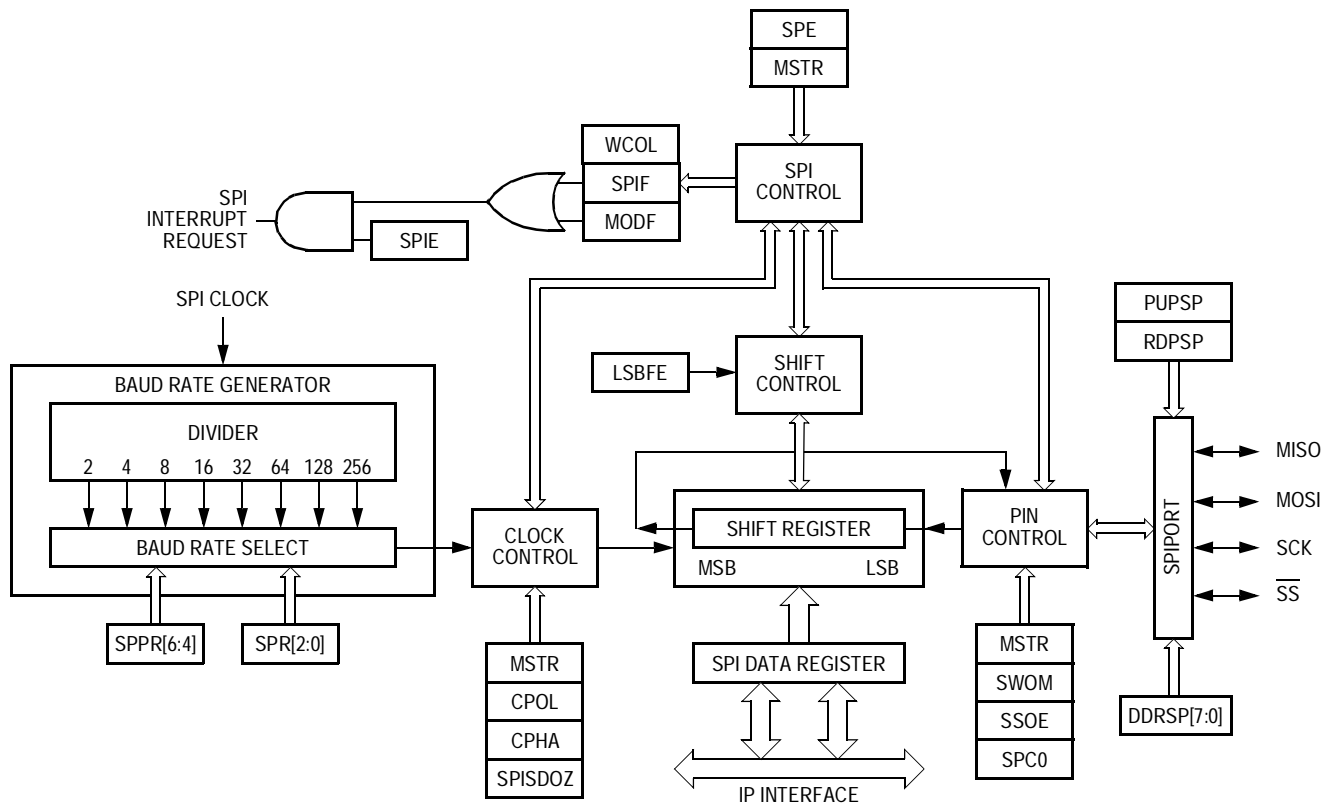

**Figure 18-1. SPI Block Diagram**

## 18.6 Signal Description

An overview of the signals is provided in [Table 18-1](#).

**Table 18-1. Signal Properties**

Name	Port	Function <sup>(1)</sup>	Reset State
MISO	SPIPORT0	Master data in/slave data out	0
MOSI	SPIPORT1	Master data out/slave data in	0
SCK	SPIPORT2	Serial clock	0
$\overline{SS}$	SPIPORT3	Slave select	0

1. The SPI ports (MISO, MOSI, SCK, and  $\overline{SS}$ ) are general-purpose I/O ports when the SPI is disabled (SPE = 0).

### 18.6.1 MISO (Master In/Slave Out)

MISO is one of the two SPI data pins.

- In master mode, MISO is the data input.
- In slave mode,  $\overline{MISO}$  is the data output and is three-stated until a master drives the  $\overline{SS}$  input pin low.
- In bidirectional mode, a slave MISO pin is the SISO pin (slave in/slave out).
- In a multiple-master system, all MISO pins are tied together.

### 18.6.2 MOSI (Master Out/Slave In)

MOSI is one of the two SPI data pins.

- In master mode, MOSI is the data output.
- In slave mode, MOSI is the data input.
- In bidirectional mode, a master MOSI pin is the MOMI pin (master out/master in).
- In a multiple-master system, all MOSI pins are tied together.



### 18.6.3 SCK (Serial Clock)

The SCK pin is the serial clock pin for synchronizing transmissions between master and slave devices.

- In master mode, SCK is an output.
- In slave mode, SCK is an input.
- In a multiple-master system, all SCK pins are tied together.

### 18.6.4 $\overline{SS}$ (Slave Select)

In master mode, the  $\overline{SS}$  pin can be:

- A mode-fault input
- A general-purpose input
- A general-purpose output
- A slave-select output

In slave mode, the  $\overline{SS}$  pin is always a slave-select input.

## 18.7 Memory Map and Registers

**Table 18-2** shows the SPI memory map.

**NOTE:** Reading reserved addresses (0x00cb\_004 and 0x00cb\_0009 through 0x00cb\_000b) and unimplemented addresses (0x00cb\_000c through 0x00cb\_000f) returns 0s. Writing to unimplemented addresses has no effect. Accessing unimplemented addresses does not generate an error response.

Table 18-2. SPI Memory Map

Address	Bits 7-0	Access <sup>(1)</sup>
0x00cb_0000	SPI Control Register 1 (SPICR1)	S/U
0x00cb_0001	SPI Control Register 2 (SPICR2)	S/U
0x00cb_0002	SPI Baud Rate Register (SPIBR)	S/U
0x00cb_0003	SPI Status Register (SPISR)	S/U
0x00cb_0005	SPI Data Register (SPIDR)	S/U
0x00cb_0006	SPI Pullup and Reduced Drive Register (SPIPURD)	S/U
0x00cb_0007	SPI Port Data Register (SPIPORT)	S/U
0x00cb_0008	SPI Port Data Direction Register (SPIDDR)	S/U

1. S/U = CPU supervisor or user mode access. User mode accesses to supervisor only addresses have no effect and result in a cycle termination transfer error.

### 18.7.1 SPI Control Register 1

Address: 0x00cb\_0000

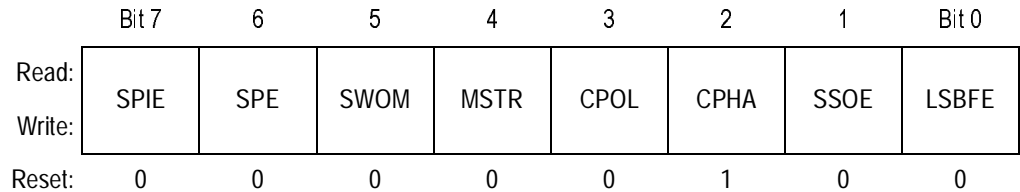

Figure 18-2. SPI Control Register 1 (SPICR1)

Read: Anytime

Write: Anytime

SPIE — SPI Interrupt Enable Bit

The SPIE bit enables the SPIF and MODF flags to generate interrupt requests. Reset clears SPIE.

1 = SPIF and MODF interrupt requests enabled

0 = SPIF and MODF interrupt requests disabled

**SPE — SPI System Enable Bit**

The SPE bit enables the SPI and dedicates SPI port pins [3:0] to SPI functions. When SPE is clear, the SPI system is initialized but in a low-power disabled state. Reset clears SPE.

1 = SPI enabled

0 = SPI disabled

**SWOM — SPI Wired-OR Mode Bit**

The SWOM bit configures the output buffers of SPI port pins [3:0] as open-drain outputs. SWOM controls SPI port pins [3:0] whether they are SPI outputs or general-purpose outputs. Reset clears SWOM.

1 = Output buffers of SPI port pins [3:0] open-drain

0 = Output buffers of SPI port pins [3:0] CMOS drive

**MSTR — Master Bit**

The MSTR bit selects SPI master mode or SPI slave mode operation. Reset clears MSTR.

1 = Master mode

0 = Slave mode

**CPOL — Clock Polarity Bit**

The CPOL bit selects an inverted or non-inverted SPI clock. To transmit data between SPI modules, the SPI modules must have identical CPOL values. Reset clears CPOL.

1 = Active-low clock; SCK idles high

0 = Active-high clock; SCK idles low

**CPHA — Clock Phase Bit**

The CPHA bit delays the first edge of the SCK clock. Reset sets CPHA.

1 = First SCK edge at start of transmission

0 = First SCK edge 1/2 cycle after start of transmission

SSOE — Slave Select Output Enable Bit

The SSOE bit and the DDRSP3 bit configure the  $\overline{SS}$  pin as a general-purpose input or a slave-select output. Reset clears SSOE.

Table 18-3.  $\overline{SS}$  Pin I/O Configurations

DDRSP3	SSOE	Master Mode	Slave Mode
0	0	Mode-fault input	Slave-select input
0	1	General-purpose input	Slave-select input
1	0	General-purpose output	Slave-select input
1	1	Slave-select output	Slave-select input

**NOTE:** Setting the SSOE bit disables the mode fault detect function.

LSBFE — LSB-First Enable Bit

The LSBFE enables data to be transmitted LSB first. Reset clears LSBFE.

1 = Data transmitted LSB first.

0 = Data transmitted MSB first

**NOTE:** In SPIDR, the MSB is always bit 7 regardless of the LSBFE bit.

**18.7.2 SPI Control Register 2**

Address: 0x00cb\_0001

	Bit 7	6	5	4	3	2	1	Bit 0
Read:	0	0	0	0	0	0	SPISDOZ	SPC0
Write:								
Reset:	0	0	0	0	0	1	0	0

= Writes have no effect and the access terminates without a transfer error exception.

**Figure 18-3. SPI Control Register 2 (SPICR2)**

Read: Anytime

Write: Anytime; writing to unimplemented bits has no effect

**SPISDOZ — SPI Stop in Doze Bit**

The SPISDOZ bit stops the SPI clocks when the CPU is in doze mode.  
 Reset clears SPISDOZ.

1 = SPI inactive in doze mode

0 = SPI active in doze mode

**SPC0 — Serial Pin Control Bit 0**

The SPC0 bit enables the bidirectional pin configurations shown in  
[Table 18-4](#). Reset clears SPC0.

**Table 18-4. Bidirectional Pin Configurations**

	Pin Mode	SPC0	MSTR	MISO Pin <sup>(1)</sup>	MOSI Pin <sup>(2)</sup>	SCK Pin <sup>(3)</sup>	$\overline{SS}$ Pin <sup>(4)</sup>
<b>A</b>	Normal	0	0	Slave data output	Slave data input	SCK input	Slave-select input
<b>B</b>			1	Master data input	Master data output	SCK output	MODF/GP input (DDRSP3 = 0) or GP output (DDRSP3 = 1)
<b>C</b>	Bidirectional	1	0	Slave data I/O	GP <sup>(5)</sup> I/O	SCK input	Slave-select input
<b>D</b>			1	GP I/O	Master data I/O	SCK output	MODF/GP input (DDRSP3 = 0) or GP output (DDRSP3 = 1)

- Slave output is enabled if SPIDDR bit 0 = 1,  $\overline{SS}$  = 0, and MSTR = 0 (A, C).
- Master output is enabled if SPIDDR bit 1 = 1 and MSTR = 1 (B, D).
- SCK output is enabled if SPIDDR bit 2 = 1 and MSTR = 1 (B, D).
- $\overline{SS}$  output is enabled if SPIDDR bit 3 = 1, SPICR1 bit 1 (SSOE) = 1, and MSTR = 1 (B, D). MODF input is enabled if SPI DDR bit 3 = 0 and SSOE = 0. GP input is enabled if SPI DDR bit 3 = 0 and SSOE = 1.
- GP = General-purpose

Serial Peripheral Interface Module (SPI)

18.7.3 SPI Baud Rate Register

Address: 0x00cb\_0002

	Bit 7	6	5	4	3	2	1	Bit 0
Read:	0	SPPR6	SPPR5	SPPR4	0	SPR2	SPR1	SPR0
Write:		SPPR6	SPPR5	SPPR4		SPR2	SPR1	SPR0
Reset:	0	0	0	0	0	0	0	0

= Writes have no effect and the access terminates without a transfer error exception.

Figure 18-4. SPI Baud Rate Register (SPIBR)

Read: Anytime

Write: Anytime; writing to unimplemented bits has no effect

SPPR[6:4] — SPI Baud Rate Preselection Bits

The SPPR[6:4] and SPR[2:0] bits select the SPI clock divisor as shown in [Table 18-5](#). Reset clears SPPR[6:4] and SPR[2:0], selecting an SPI clock divisor of 2.

SPR[2:0] — SPI Baud Rate Bits

The SPPR[6:4] and SPR[2:0] bits select the SPI clock divisor as shown in [Table 18-5](#). Reset clears SPPR[6:4] and SPR[2:0], selecting an SPI clock divisor of 2.

**NOTE:** Writing to SPIBR during a transmission may cause spurious results.

**Table 18-5. SPI Baud Rate Selection (33-MHz Module Clock)**

SPPR[6:4]	SPR[2:0]	SPI Clock Divisor	Baud Rate	SPPR[6:4]	SPR[2:0]	SPI Clock Divisor	Baud Rate
000	000	2	16.5 MHz	100	000	10	3.3 MHz
000	001	4	8.25 MHz	100	001	20	1.65 MHz
000	010	8	4.125 MHz	100	010	40	825 MHz
000	011	16	2.06 MHz	100	011	80	412.5 kHz
000	100	32	1.03 MHz	100	100	160	206.25 kHz
000	101	64	515.62 kHz	100	101	320	103.13 kHz
000	110	128	257.81 kHz	100	110	640	51.56 kHz
000	111	256	128.9 kHz	100	111	1280	25.78 kHz
001	000	4	8.25 MHz	101	000	12	2.75 MHz
001	001	8	4.12 MHz	101	001	24	1.375 MHz
001	010	16	2.06 MHz	101	010	48	687.5 kHz
001	011	32	1.03 MHz	101	011	96	343.75 kHz
001	100	64	515.62 kHz	101	100	192	171.88 kHz
001	101	128	257.81 kHz	101	101	384	85.94 kHz
001	110	256	128.9 kHz	101	110	768	42.97 kHz
001	111	512	64.45 kHz	101	111	1536	21.48 kHz
010	000	6	5.5 MHz	110	000	14	2.36 MHz
010	001	12	2.75 MHz	110	001	28	1.18 MHz
010	010	24	1.375 MHz	110	010	56	589.29 kHz
010	011	48	687.5 kHz	110	011	112	296.64 kHz
010	100	96	343.75 kHz	110	100	224	147.32 kHz
010	101	192	171.88 kHz	110	101	448	73.66 kHz
010	110	384	85.94 kHz	110	110	896	36.83 kHz
010	111	768	42.97 kHz	110	111	1792	18.42 kHz
011	000	8	4.13 MHz	111	000	16	2.06 MHz
011	001	16	2.06 MHz	111	001	32	1.03 MHz
011	010	32	1.03 MHz	111	010	64	515.63 kHz
011	011	64	515.63 kHz	111	011	128	257.81 kHz
011	100	128	257.81 kHz	111	100	256	128.91 kHz
011	101	256	128.91 kHz	111	101	512	64.45 kHz
011	110	512	64.45 kHz	111	110	1024	32.23 kHz
011	111	1024	32.23 kHz	111	111	2048	16.11 kHz

**Serial Peripheral Interface Module (SPI)**

**18.7.4 SPI Status Register**

Address: 0x00cb\_0003

	Bit 7	6	5	4	3	2	1	Bit 0
Read:	SPIF	WCOL	0	MODF	0	0	0	0
Write:								
Reset:	0	0	0	0	0	0	0	0

 = Writes have no effect and the access terminates without a transfer error exception.

**Figure 18-5. SPI Status Register (SPISR)**

Read: Anytime

Write: Has no meaning or effect

**SPIF — SPI Interrupt Flag**

The SPIF flag is set after the eighth SCK cycle in a transmission when received data transfers from the shift register to SPIDR. If the SPIE bit is also set, SPIF generates an interrupt request. Once SPIF is set, no new data can be transferred into SPIDR until SPIF is cleared. Clear SPIF by reading SPISR with SPIF set and then accessing SPIDR. Reset clears SPIF.

- 1 = New data available in SPIDR
- 0 = No new data available in SPIDR

**WCOL — Write Collision Flag**

The WCOL flag is set when software writes to SPIDR during a transmission. Clear WCOL by reading SPISR with WCOL set and then accessing SPIDR. Reset clears WCOL.

- 1 = Write collision
- 0 = No write collision

**MODF — Mode Fault Flag**

The MODF flag is set when the  $\overline{SS}$  pin of a master SPI is driven low and the  $\overline{SS}$  pin is configured as a mode-fault input. If the SPIE bit is also set, MODF generates an interrupt request. A mode fault clears the SPE, MSTR, and DDRSP[2:0] bits. Clear MODF by reading SPISR with MODF set and then writing to SPICR1. Reset clears MODF.

- 1 = Mode fault
- 0 = No mode fault



**18.7.5 SPI Data Register**

Address: 0x00cb\_0005

	Bit 7	6	5	4	3	2	1	Bit 0
Read:	BIT 7	6	5	4	3	2	1	BIT 0
Write:								
Reset:	0	0	0	0	0	0	0	0

**Figure 18-6. SPI Data Register (SPIDR)**

Read: Anytime; normally read only after SPIF is set

Write: Anytime; see WCOL

SPIDR is both the input and output register for SPI data. Writing to SPIDR while a transmission is in progress sets the WCOL flag and disables the attempted write. Read SPIDR after the SPIF flag is set and before the end of the next transmission. If the SPIF flag is not serviced before a new byte enters the shift register, the new byte and any successive bytes are lost. The byte already in the SPIDR remains there until SPIF is serviced.

**Serial Peripheral Interface Module (SPI)**

**18.7.6 SPI Pullup and Reduced Drive Register**

Address: 0x00cb\_0006

	Bit 7	6	5	4	3	2	1	Bit 0
Read:	0	0	RSVD5	RDPSP	0	0	RSVD1	PUPSP
Write:								
Reset:	0	0	0	0	0	0	0	0

= Writes have no effect and the access terminates without a transfer error exception.

**Figure 18-7. SPI Pullup and Reduced Drive Register (SPIPURD)**

Read: Anytime

Write: Anytime; writing to unimplemented bits has no effect

RSVD5 and RSVD1 — Reserved

Writing to these read/write bits updates their values but has no effect on functionality.

RDPSP — SPI Port Reduced Drive Control Bit

- 1 = Reduced drive capability on SPIPORT bits [7:4]
- 0 = Full drive enabled on SPIPORT bits [7:4]

PUPSP — SPI Port Pullup Enable Bit

- 1 = Pullup devices enabled for SPIPORT bits [3:0]
- 0 = Pullup devices disabled for SPIPORT bits [3:0]

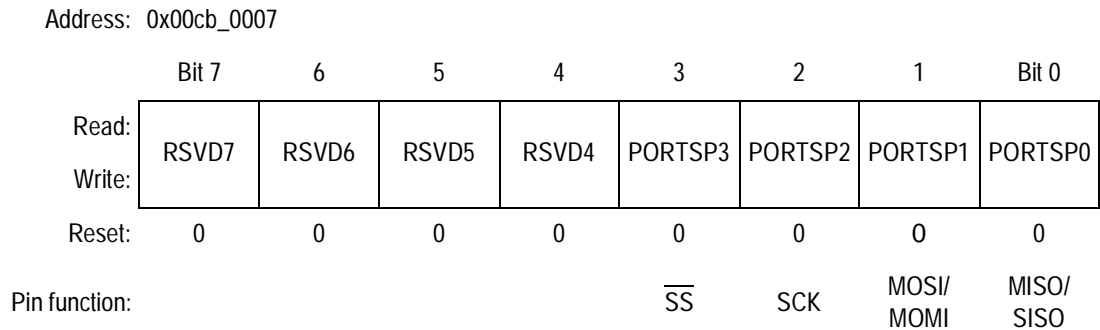
**18.7.7 SPI Port Data Register**

**Figure 18-8. SPI Port Data Register (SPIPORT)**

Read: Anytime

Write: Anytime

RSVD[7:4] — Reserved

Writing to these read/write bits updates their values but has no effect on functionality.

PORTSP[3:0] — SPI Port Data Bits

Data written to SPIPORT drives pins only when they are configured as general-purpose outputs.

Reading an input (DDRSP bit clear) returns the pin level; reading an output (DDRSP bit set) returns the pin driver input level.

Writing to any of the PORTSP[3:0] pins does not change the pin state when the pin is configured for SPI output.

SPIPORT I/O function depends upon the state of the SPE bit in SPICR1 and the state the DDRSP bits in SPIDDR.

**Table 18-6. SPI Port Summary**

Pullup Enable Control			Reduced Drive Control			Wired-OR Mode Control		
Register	Bit	Reset State	Register	Bit	Reset State	Register	Bit	Reset State
SPIPURD	PUPSP	0	SPIPURD	RDPSP[1:0]	Full drive	SPICR1	SWOM	Normal

Serial Peripheral Interface Module (SPI)

18.7.8 SPI Port Data Direction Register

Address: 0x00cb\_0008

	Bit 7	6	5	4	3	2	1	Bit 0
Read:	RSVD7	RSVD6	RSVD5	RSVD4	DDRSP3	DDRSP2	DDRSP1	DDRSP0
Write:								
Reset:	0	0	0	0	0	0	0	0
Pin function:					$\overline{SS}$	SCK	MOSI/ MOMI	MISO/ SISO

Figure 18-9. SPI Port Data Direction Register (SPIDDR)

Read: Anytime

Write: Anytime

RSVD[7:4] — Reserved

Writing to these read/write bits updates their values but has no effect on functionality.

DDRSP[3:0] — Data Direction Bits

The DDRSP[3:0] bits control the data direction of SPIPORT pins. Reset clears DDRSP[3:0].

- 1 = Corresponding pin configured as output
- 0 = Corresponding pin configured as input

In slave mode, DDRSP3 has no meaning or effect. In master mode, the DDRSP3 and the SSOE bits determine whether SPI port pin 3 is a mode-fault input, a general-purpose input, a general-purpose output, or a slave-select output.

**NOTE:** When the SPI is enabled ( $SPE = 1$ ), the MISO, MOSI, and SCK pins:

- Are inputs if their SPI functions are input functions regardless of the state of their DDRSP bits.
- Are outputs if their SPI functions are output functions only if their DDRSP bits are set.

## 18.8 Functional Description

The SPI module allows full-duplex, synchronous, serial communication between the MCU and peripheral devices. Software can poll the SPI status flags or SPI operation can be interrupt driven.

Setting the SPE bit in SPICR1 enables the SPI and dedicates four SPI port pins to SPI functions:

- Slave select ( $\overline{SS}$ )
- Serial clock (SCK)
- Master out/slave in (MOSI)
- Master in/slave out (MISO)

When the SPE bit is clear, the  $\overline{SS}$ , SCK, MOSI, and MISO pins are general-purpose I/O pins controlled by SPIDDR.

The 8-bit shift register in a master SPI is linked by the MOSI and MISO pins to the 8-bit shift register in the slave. The linked shift registers form a distributed 16-bit register. In an SPI transmission, the SCK clock from the master shifts the data in the 16-bit register eight bit positions, and the master and slave exchange data. Data written to the master SPIDR register is the output data to the slave. After the exchange, data read from the master SPIDR is the input data from the slave.

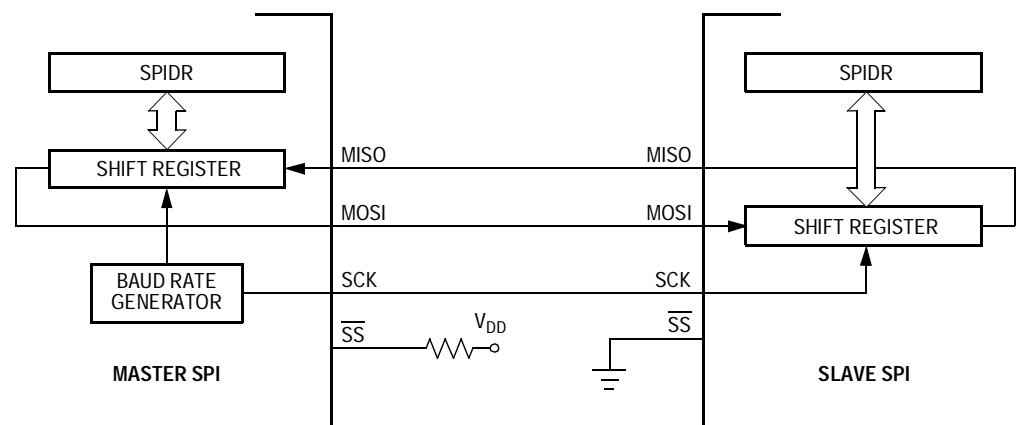

**Figure 18-10. Full-Duplex Operation**

### 18.8.1 Master Mode

Setting the MSTR bit in SPICR1 puts the SPI in master mode. Only a master SPI can initiate a transmission. Writing to the master SPIDR begins a transmission. If the shift register is empty, the byte transfers to the shift register and begins shifting out on the MOSI pin under the control of the master SCK clock. The SCK clock starts one-half SCK cycle after writing to SPIDR.

The SPR[2:0] and SPPR[6:4] bits in SPIBR control the baud rate generator and determine the speed of the shift register. The SCK pin is the SPI clock output. Through the SCK pin, the baud rate generator of the master controls the shift register of the slave.

The MSTR bit in SPICR1 and the SPC0 bit in SPICR2 control the function of the data pins, MOSI and MISO.

The  $\overline{SS}$  pin is normally an input that remains in the inactive high state. Setting the DDRSP3 bit in SPIDDR configures  $\overline{SS}$  as an output. The DDRSP3 bit and the SSOE bit in SPICR1 can configure  $\overline{SS}$  for general-purpose I/O, mode fault detection, or slave selection. See [Table 18-3](#).

The  $\overline{SS}$  output goes low during each transmission and is high when the SPI is in the idle state. Driving the master  $\overline{SS}$  input low sets the MODF flag in SPISR, indicating a mode fault. More than one master may be trying to drive the MOSI and SCK lines simultaneously. A mode fault clears the data direction bits of the MISO, MOSI (or MOMI), and SCK pins to make them inputs. A mode fault also clears the SPE and MSTR bits in SPICR1. If the SPIE bit is also set, the MODF flag generates an interrupt request.

## 18.8.2 Slave Mode

Clearing the MSTR bit in SPICR1 puts the SPI in slave mode. The SCK pin is the SPI clock input from the master, and the  $\overline{SS}$  pin is the slave-select input. For a transmission to occur, the  $\overline{SS}$  pin must be driven low and remain low until the transmission is complete.

The MSTR bit and the SPC0 bit in SPICR2 control the function of the data pins, MOSI and MISO. The  $\overline{SS}$  input also controls the MISO pin. If  $\overline{SS}$  is low, the MSB in the shift register shifts out on the MISO pin. If  $\overline{SS}$  is high, the MISO pin is in a high impedance state, and the slave ignores the SCK input.

**NOTE:** *When using peripherals with full-duplex capability, do not simultaneously enable two receivers that drive the same MISO output line.*

As long as only one slave drives the master input line, it is possible for several slaves to receive the same transmission simultaneously.

If the CPHA bit in SPICR1 is clear, odd-numbered edges on the SCK input latch the data on the MOSI pin. Even-numbered edges shift the data into the LSB position of the SPI shift register and shift the MSB out to the MISO pin.

If the CPHA bit is set, even-numbered edges on the SCK input latch the data on the MOSI pin. Odd-numbered edges shift the data into the LSB position of the SPI shift register and shift the MSB out to the MISO pin.

The transmission is complete after the eighth shift. The received data transfers to SPIDR, setting the SPIF flag in SPISR.

### 18.8.3 Transmission Formats

The CPHA and CPOL bits in SPICR1 select one of four combinations of serial clock phase and polarity. Clock phase and polarity must be identical for the master SPI device and the communicating slave device.

#### 18.8.3.1 Transfer Format When CPHA = 1

Some peripherals require the first SCK edge to occur before the slave MSB becomes available at its MISO pin. When the CPHA bit is set, the master SPI waits for a synchronization delay of one-half SCK clock cycle. Then it issues the first SCK edge at the beginning of the transmission. The first edge causes the slave to transmit its MSB to the MISO pin of the master. The second edge and the following even-numbered edges latch the data. The third edge and the following odd-numbered edges shift the latched slave data into the master shift register and shift master data out on the master MOSI pin.

After the 16th and final SCK edge:

- Data that was in the master SPIDR register is in the slave SPIDR. Data that was in the slave SPIDR register is in the master SPIDR.
- The SCK clock stops and the SPIF flag in SPISR is set, indicating that the transmission is complete. If the SPIE bit in SPCR1 is set, SPIF generates an interrupt request.

**Figure 18-11** shows the timing of a transmission with the CPHA bit set. The  $\overline{SS}$  pin of the master must be either high or configured as a general-purpose output not affecting the SPI.

When CPHA = 1, the slave  $\overline{SS}$  line can remain low between bytes. This format is good for systems with a single master and a single slave driving the MISO data line.

Writing to SPIDR while a transmission is in progress sets the WCOL flag to indicate a write collision and inhibits the write. WCOL does not generate an interrupt request; the SPIF interrupt request comes at the end of the transfer that was in progress at the time of the error.



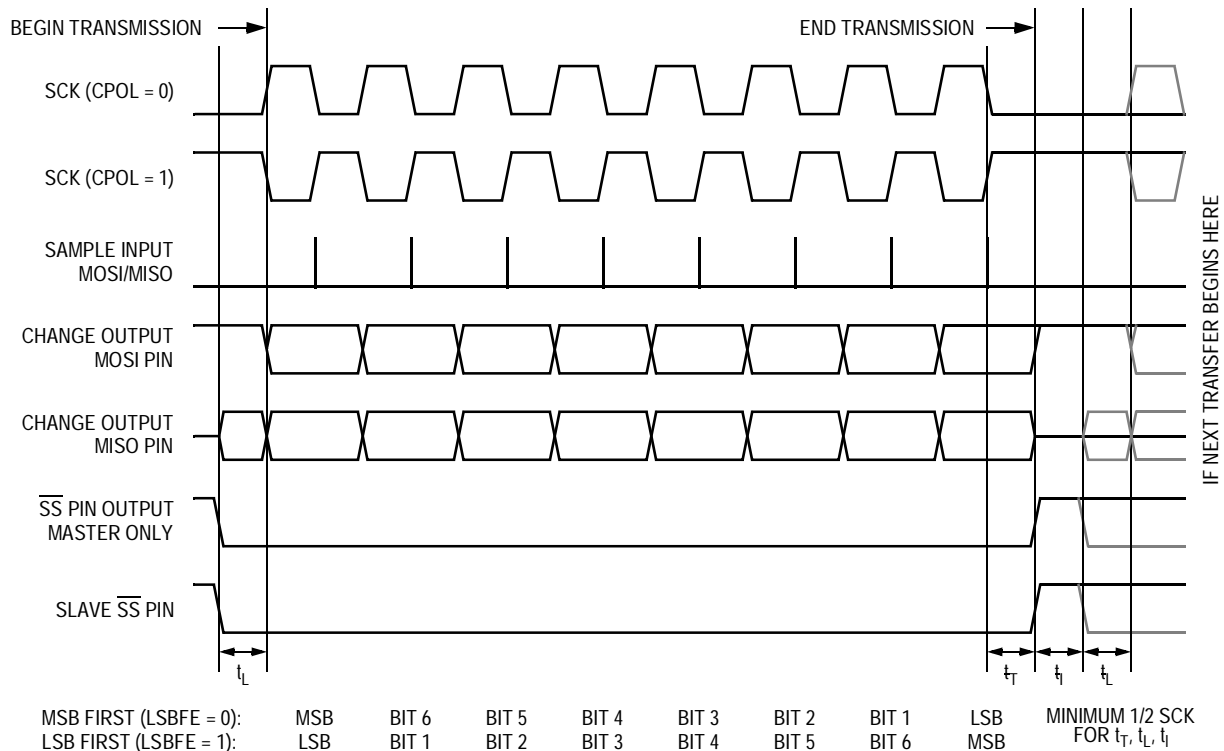

Legend:  
 $t_L$  = Minimum leading time before the first SCK edge  
 $t_T$  = Minimum trailing time after the last SCK edge  
 $t_I$  = Minimum idling time between transmissions (minimum SS high time)  
 $t_L$ ,  $t_T$ , and  $t_I$  are guaranteed for master mode and required for slave mode.

**Figure 18-11. SPI Clock Format 1 (CPHA = 1)**

### 18.8.3.2 Transfer Format When CPHA = 0

In some peripherals, the slave MSB is available at its MISO pin as soon as the slave is selected. When the CPHA bit is clear, the master SPI delays its first SCK edge for half a SCK cycle after the transmission starts. The first edge and all following odd-numbered edges latch the slave data. Even-numbered SCK edges shift slave data into the master shift register and shift master data out on the master MOSI pin.

Serial Peripheral Interface Module (SPI)

After the 16th and final SCK edge:

- Data that was in the master SPIDR is in the slave SPIDR. Data that was in the slave SPIDR is in the master SPIDR.
- The SCK clock stops and the SPIF flag in SPISR is set, indicating that the transmission is complete. If the SPIE bit in SPCR1 is set, SPIF generates an interrupt request.

Figure 18-12 shows the timing of a transmission with the CPHA bit clear. The  $\overline{SS}$  pin of the master must be either high or configured as a general-purpose output not affecting the SPI.

When CPHA = 0, the slave  $\overline{SS}$  pin must be negated and reasserted between bytes.

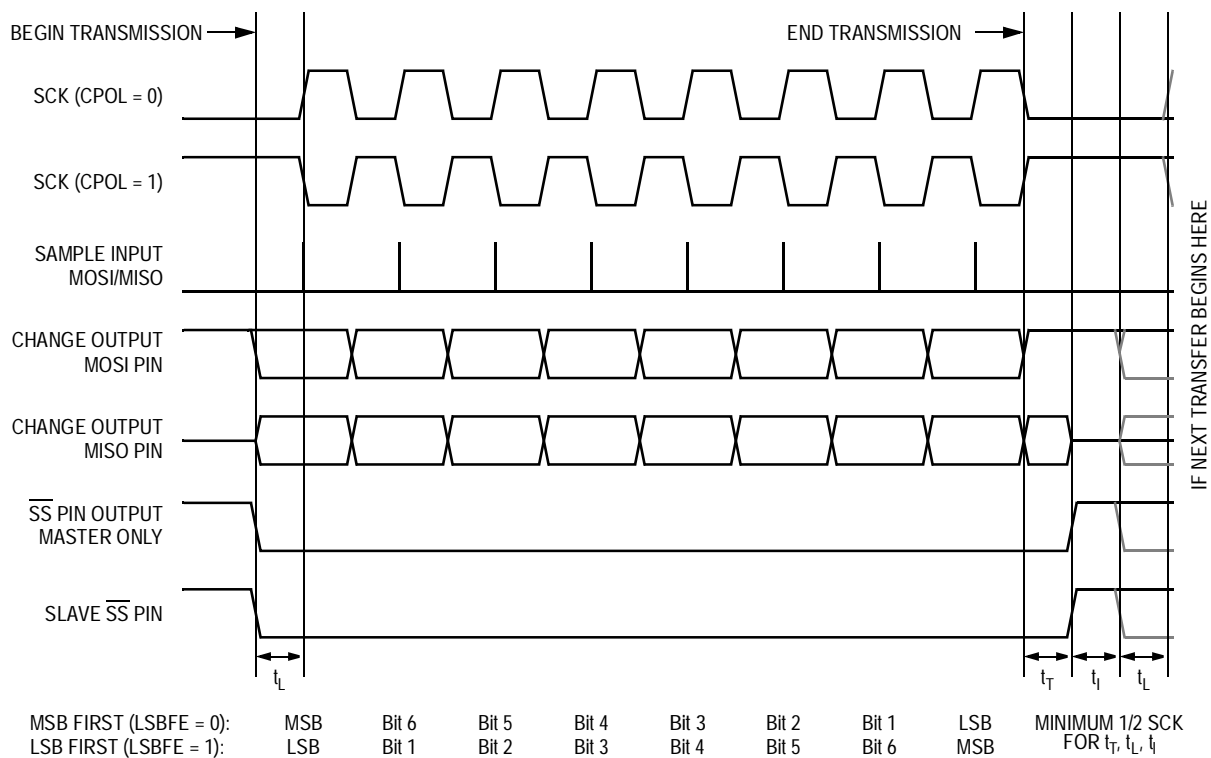

Legend:  
 $t_L$  = Minimum leading time before the first SCK edge  
 $t_T$  = Minimum trailing time after the last SCK edge  
 $t_I$  = Minimum idling time between transmissions (minimum  $\overline{SS}$  high time)  
 $t_L$ ,  $t_T$ , and  $t_I$  are guaranteed for master mode and required for slave mode.

Figure 18-12. SPI Clock Format 0 (CPHA = 0)

**NOTE:** Clock skew between the master and slave can cause data to be lost when:

- $CPHA = 0$ , and,
- The baud rate is the SPI clock divided by two, and
- The master SCK frequency is half the slave SPI clock frequency, and
- Software writes to the slave SPIDR just before the synchronized  $\overline{SS}$  signal goes low.

The synchronized  $\overline{SS}$  signal is synchronized to the SPI clock. **Figure 18-13** shows an example with the synchronized  $\overline{SS}$  signal almost a full SPI clock cycle late. While the synchronized  $\overline{SS}$  of the slave is high, writing is allowed even though the  $\overline{SS}$  pin is already low. The write can change the MISO pin while the master is sampling the MISO line. The first bit of the transfer may not be stable when the master samples it, so the byte sent to the master may be corrupted.

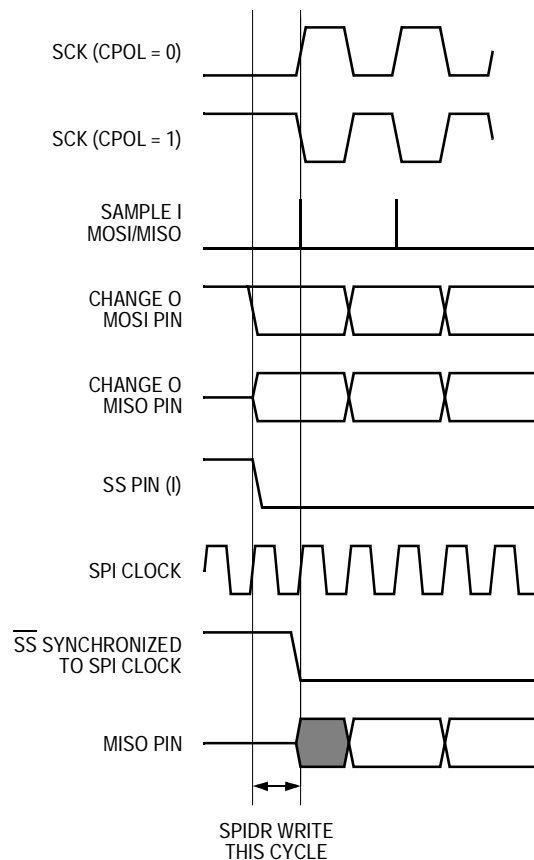

**Figure 18-13. Transmission Error Due to Master/Slave Clock Skew**

Also, if the slave generates a late write, its state machine may not have time to reset, causing it to incorrectly receive a byte from the master.

This error is most likely when the SCK frequency is half the slave SPI clock frequency. At other baud rates, the SCK skew is no more than one SPI clock, and there is more time between the synchronized  $\overline{SS}$  signal and the first SCK edge. For example, with a SCK frequency one-fourth the slave SPI clock frequency, there are two SPI clocks between the fall of  $\overline{SS}$  and the SCK edge.

As long as another late SPIDR write does not occur, the following bytes to and from the slave are correctly transmitted.

#### 18.8.4 SPI Baud Rate Generation

The baud rate generator divides the SPI clock to produce the SPI baud clock. The SPPR[6:4] and SPR[2:0] bits in SPIBR select the SPI clock divisor:

$$\text{SPI clock divisor} = (\text{SPPR} + 1) \times 2(\text{SPR} + 1)$$

where:

SPPR = the value written to bits SPPR[6:4]

SPR = the value written to bits SPR[2:0]

The baud rate generator is active only when the SPI is in master mode and transmitting. Otherwise, the divider is inactive to reduce  $I_{DD}$  current.

#### 18.8.5 Slave-Select Output

The slave-select output feature automatically drives the  $\overline{SS}$  pin low during transmission to select external devices and drives it high during idle to deselect external devices. When  $\overline{SS}$  output is selected, the  $\overline{SS}$  output pin is connected to the  $\overline{SS}$  input pin of the external device.

In master mode only, setting the SSOE bit in SPICR1 and the DDRSP[3] bit in SPIDDR configures the  $\overline{SS}$  pin as a slave-select output.

Setting the SSOE bit disables the mode fault feature.

**NOTE:** *Be careful when using the slave-select output feature in a multimaster system. The mode fault feature is not available for detecting system errors between masters.*

### 18.8.6 Bidirectional Mode

Setting the SPC0 bit in SPICR1 selects bidirectional mode (see [Table 18-7](#)). The SPI uses only one data pin for the interface with external device(s). The MSTR bit determines which pin to use. In master mode, the MOSI pin is the master out/master in pin, MOMI. In slave mode, the MISO pin is the slave out/slave in pin, SISO. The MISO pin in master mode and MOSI pin in slave mode are general-purpose I/O pins.

The direction of each data I/O pin depends on its data direction register bit. A pin configured as an output is the output from the shift register. A pin configured as an input is the input to the shift register, and data coming out of the shift register is discarded.

The SCK pin is an output in master mode and an input in slave mode.

The  $\overline{SS}$  pin can be an input or an output in master mode, and it is always an input in slave mode.

In bidirectional mode, a mode fault does not clear DDRSP0, the data direction bit for the SISO pin.

**Table 18-7. Normal Mode and Bidirectional Mode**

SPE = 1	Master Mode, MSTR = 1	Slave Mode, MSTR = 0
<b>Normal Mode</b> SPC0 = 0		
<b>Bidirectional Mode</b> SPC0 = 1		

## Serial Peripheral Interface Module (SPI)

## 18.8.7 Error Conditions

The SPI has two error conditions:

- Write collision error
- Mode fault error

## 18.8.7.1 Write Collision Error

The WCOL flag in SPISR indicates that a serial transfer was in progress when the MCU tried to write new data to SPIDR. Valid write times are listed below (see [Figure 18-11](#) and [Figure 18-12](#) for definitions of  $t_T$  and  $t_I$ ):

- In master mode, a valid write is within  $t_I$  (when  $\overline{SS}$  is high).
- In slave phase 0, a valid write within  $t_I$  (when  $\overline{SS}$  is high).
- In slave phase 1, a valid write is within  $t_T$  or  $t_I$  (after the last SCK edge and before  $\overline{SS}$  goes low), excluding the first two SPI clocks after the last SCK edge (the beginning of  $t_T$  is an illegal write).

A write during any other time causes a WCOL error. The write is disabled to avoid writing over the data being transmitted. WCOL does not generate an interrupt request because the WCOL flag can be read upon completion of the transmission that was in progress at the time of the error.

## 18.8.7.2 Mode Fault Error

If the  $\overline{SS}$  input of a master SPI goes low, it indicates a system error in which more than one master may be trying to drive the MOSI and SCK lines simultaneously. This condition is not permitted in normal operation; it sets the MODF flag in SPISR. If the SPIE bit in SPICR1 is also set, MODF generates an interrupt request.

Configuring the  $\overline{SS}$  pin as a general-purpose output or a slave-select output disables the mode fault function.

A mode fault clears the SPE and MSTR bits and the DDRSP bits of the SCK, MISO, and MOSI (or MOMI) pins. This forces those pins to be high-impedance inputs to avoid any conflict with another output driver.

If the mode fault error occurs in bidirectional mode, the DDRSP bit of the SISO pin is not affected, since it is a general-purpose I/O pin.

## 18.8.8 Low-Power Mode Options

This subsection describes the low-power mode options.

### 18.8.8.1 Run Mode

Clearing the SPE bit in SPICR1 puts the SPI in a disabled, low-power state. SPI registers are accessible, but SPI clocks are disabled.

### 18.8.8.2 Doze Mode

SPI operation in doze mode depends on the state of the SPISDOZ bit in SPICR2.

- If SPISDOZ is clear, the SPI operates normally in doze mode.
- If SPISDOZ is set, the SPI clock stops, and the SPI enters a low-power state in doze mode.
  - Any master transmission in progress stops at doze mode entry and resumes at doze mode exit.
  - Any slave transmission in progress continues if a master continues to drive the slave SCK pin. The slave stays synchronized to the master SCK clock.

**NOTE:** *Although the slave shift register can receive MOSI data, it cannot transfer data to SPIDR or set the SPIF flag in doze or stop mode. If the slave enters doze mode in an idle state and exits doze mode in an idle state, SPIF remains clear and no transfer to SPIDR occurs.*

### 18.8.8.3 Stop Mode

SPI operation in stop mode is the same as in doze mode with the SPISDOZ bit set.

## 18.9 Reset

Reset initializes the SPI registers to a known startup state as described in **18.7 Memory Map and Registers**. A transmission from a slave after reset and before writing to the SPIDR register is either indeterminate or the byte last received from the master before the reset. Reading the SPIDR after reset returns 0s.

## 18.10 Interrupts

**Table 18-8. SPI Interrupt Request Sources**

Interrupt Request	Flag	Enable Bit
Mode fault	MODF	SPIE
Transmission complete	SPIF	

### 18.10.1 Mode Fault (MODF) Flag

MODF is set when the  $\overline{SS}$  pin of a master SPI is driven low and the  $\overline{SS}$  pin is configured as a mode-fault input. If the SPIE bit is also set, MODF generates an interrupt request. A mode fault clears the SPE, MSTR, and DDRSP[2:0] bits. Clear MODF by reading SPISR with MODF set and then writing to SPICR1. Reset clears MODF.

### 18.10.2 SPI Interrupt Flag (SPIF)

SPIF is set after the eighth SCK cycle in a transmission when received data transfers from the shift register to SPIDR. If the SPIE bit is also set, SPIF generates an interrupt request. Once SPIF is set, no new data can be transferred into SPIDR until SPIF is cleared. Clear SPIF by reading SPISR with SPIF set and then accessing SPIDR. Reset clears SPIF.



## Section 19. Queued Analog-to-Digital Converter (QADC)

### 19.1 Contents

19.2	Introduction	427
19.3	Features	428
19.4	Block Diagram	429
19.5	Modes of Operation	430
19.5.1	Debug Mode	430
19.5.2	Stop Mode	431
19.6	Signals	431
19.6.1	Port QA Pin Functions	432
19.6.1.1	Port QA Analog Input Pins	432
19.6.1.2	Port QA Digital Input/Output Pins	433
19.6.2	Port QB Pin Functions	433
19.6.2.1	Port QB Analog Input Pins	433
19.6.2.2	Port QB Digital Input Pins	433
19.6.3	External Trigger Input Pins	434
19.6.4	Multiplexed Address Output Pins	434
19.6.5	Multiplexed Analog Input Pins	435
19.6.6	Voltage Reference Pins	435
19.6.7	Dedicated Analog Supply Pins	435
19.6.8	Dedicated Digital I/O Port Supply Pin	435
19.7	Memory Map	436
19.8	Register Descriptions	437
19.8.1	QADC Module Configuration Register (QADCMCR)	437
19.8.2	QADC Test Register (QADCTEST)	438
19.8.3	Port Data Registers (PORTQA and PORTQB)	438
19.8.4	Port QA and QB Data Direction Register (DDRQA and DDRQB)	440

**Queued Analog-to-Digital Converter (QADC)**

19.8.5	Control Registers . . . . .	442
19.8.5.1	QADC Control Register 0 (QACR0) . . . . .	442
19.8.5.2	QADC Control Register 1 (QACR1) . . . . .	445
19.8.5.3	QADC Control Register 2 (QACR2) . . . . .	448
19.8.6	Status Registers . . . . .	453
19.8.6.1	QADC Status Register 0 (QASR0) . . . . .	453
19.8.6.2	QADC Status Register 1 (QASR1) . . . . .	462
19.8.7	Conversion Command Word Table (CCW) . . . . .	463
19.8.8	Result Registers . . . . .	468
19.8.8.1	Right-Justified Unsigned Result Register (RJURR) . . . . .	468
19.8.8.2	Left-Justified Signed Result Register (LJSRR) . . . . .	469
19.8.8.3	Left-Justified Unsigned Result Register (LJURR) . . . . .	470
19.9	Functional Description . . . . .	470
19.9.1	Result Coherency . . . . .	470
19.9.2	External Multiplexing . . . . .	471
19.9.2.1	External Multiplexing Operation . . . . .	471
19.9.2.2	Module Version Options . . . . .	473
19.9.3	Analog Subsystem . . . . .	474
19.9.3.1	Analog-to-Digital Converter Operation . . . . .	474
19.9.3.2	Conversion Cycle Times . . . . .	475
19.9.3.3	Channel Decode and Multiplexer . . . . .	476
19.9.3.4	Sample Buffer . . . . .	476
19.9.3.5	Digital-to-Analog Converter (DAC) Array . . . . .	476
19.9.3.6	Comparator . . . . .	477
19.9.3.7	Bias . . . . .	477
19.9.3.8	Successive Approximation Register . . . . .	477
19.9.3.9	State Machine . . . . .	477
19.10	Digital Control . . . . .	478
19.10.1	Queue Priority Timing Examples . . . . .	478
19.10.1.1	Queue Priority . . . . .	478
19.10.1.2	Queue Priority Schemes . . . . .	481
19.10.2	Boundary Conditions . . . . .	492
19.10.3	Scan Modes . . . . .	493
19.10.4	Disabled Mode . . . . .	494
19.10.5	Reserved Mode . . . . .	494
19.10.6	Single-Scan Modes . . . . .	494
19.10.6.1	Software-Initiated Single-Scan Mode . . . . .	495

19.10.6.2	Externally Triggered Single-Scan Mode . . . . .	496
19.10.6.3	Externally Gated Single-Scan Mode . . . . .	497
19.10.6.4	Interval Timer Single-Scan Mode . . . . .	497
19.10.7	Continuous-Scan Modes . . . . .	499
19.10.7.1	Software-Initiated Continuous-Scan Mode . . . . .	500
19.10.7.2	Externally Triggered Continuous-Scan Mode . . . . .	501
19.10.7.3	Externally Gated Continuous-Scan Mode . . . . .	501
19.10.7.4	Periodic Timer Continuous-Scan Mode . . . . .	502
19.10.8	QADC Clock (QCLK) Generation . . . . .	503
19.10.9	Periodic/Interval Timer . . . . .	504
19.10.10	Conversion Command Word Table . . . . .	505
19.10.11	Result Word Table . . . . .	509
19.11	Pin Connection Considerations . . . . .	509
19.11.1	Analog Reference Pins . . . . .	509
19.11.2	Analog Power Pins . . . . .	510
19.11.3	Conversion Timing Schemes . . . . .	512
19.11.4	Analog Supply Filtering and Grounding . . . . .	515
19.11.5	Accommodating Positive/Negative Stress Conditions . . . . .	517
19.11.6	Analog Input Considerations . . . . .	519
19.11.7	Analog Input Pins . . . . .	521
19.11.7.1	Settling Time for the External Circuit . . . . .	522
19.11.7.2	Error Resulting from Leakage . . . . .	523
19.12	Interrupts . . . . .	524
19.12.1	Interrupt Operation . . . . .	524
19.12.2	Interrupt Sources . . . . .	525

## 19.2 Introduction

The queued analog-to-digital converter (QADC) is a 10-bit, unipolar, successive approximation converter. Up to eight analog input channels can be supported using internal multiplexing. A maximum of 18 input channels can be supported in the expanded, externally multiplexed mode.

The QADC consists of an analog front-end and a digital control subsystem, which includes an IPbus interface block.

## Queued Analog-to-Digital Converter (QADC)

The analog section includes input pins, an analog multiplexer, and sample and hold analog circuits. The analog conversion is performed by the digital-to-analog converter (DAC) resistor-capacitor (RC) array and a high-gain comparator.

The digital control section contains queue control logic to sequence the conversion process and interrupt generation logic. Also included are the periodic/interval timer, control and status registers, the conversion command word (CCW) table, random-access memory (RAM), and the result table RAM.

The bus interface unit (BIU) provides access to registers that configure the QADC, control the analog-to-digital converter and queue mechanism, and present formatted conversion results.

### 19.3 Features

Features of the QADC module include:

- Internal sample and hold
- Up to eight analog input channels using internal multiplexing
- Up to four external analog multiplexers directly supported
- Up to 18 total input channels with internal and external multiplexing
- Programmable input sample time for various source impedances
- Two conversion command word (CCW) queues with a total of 64 entries for setting conversion parameters of each A/D conversion
- Subqueues possible using pause mechanism
- Queue complete and pause interrupts available on both queues
- Queue pointers indicating current location for each queue
- Automated queue modes initiated by:
  - External edge trigger and gated trigger
  - Periodic/interval timer, within QADC module (queues 1 and 2)
  - Software command

- Single scan or continuous scan of queues
- 64 result registers
- Output data readable in three formats:
  - Right-justified unsigned
  - Left-justified signed
  - Left-justified unsigned
- Unused analog channels can be used as discrete input/output pins.

### 19.4 Block Diagram

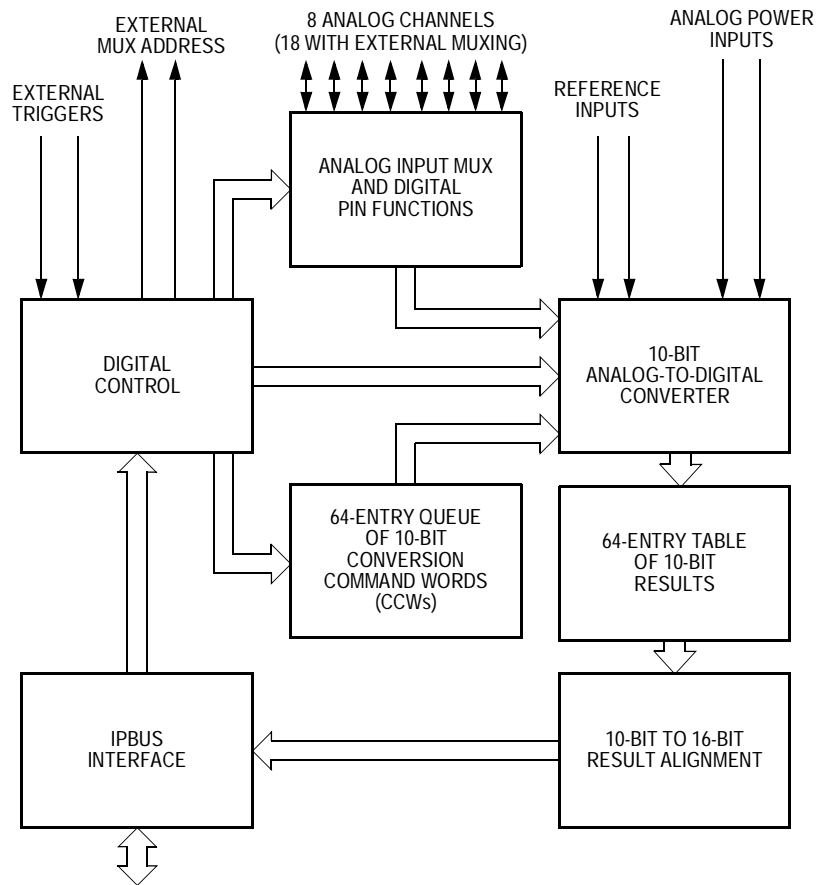

**Figure 19-1. QADC Block Diagram**

## 19.5 Modes of Operation

This subsection describes the two modes of operation in which the QADC does not perform conversions in a regular fashion:

- Debug mode
- Stop mode

### 19.5.1 Debug Mode

The QDBG bit in the Module Configuration Register (QADCMCR) governs behavior of the QADC when the CPU enters background debug mode. When QDBG is clear, the QADC operates normally and is unaffected by CPU background debug mode. See [19.8.1 QADC Module Configuration Register \(QADCMCR\)](#).

When QDBG is set and the CPU enters background debug mode, the QADC finishes any conversion in progress and then freezes. This is QADC debug mode. Depending on when debug mode is entered, the three possible queue freeze scenarios are:

- When a queue is not executing, the QADC freezes immediately.
- When a queue is executing, the QADC completes the current conversion and then freezes.
- If during the execution of the current conversion, the queue operating mode for the active queue is changed, or a queue 2 abort occurs, the QADC freezes immediately.

When the QADC enters debug mode while a queue is active, the current CCW location of the queue pointer is saved.

Debug mode:

- Stops the analog clock
- Holds the periodic/interval timer in reset
- Prevents external trigger events from being captured
- Keeps all QADC registers and RAM accessible

Although the QADC saves a pointer to the next CCW in the current queue, software can force the QADC to execute a different CCW by reconfiguring the QADC. When the QADC exits debug mode, it looks at the queue operating modes, the current queue pointer, and any pending trigger events to decide which CCW to execute.

## 19.5.2 Stop Mode

The QADC enters a low-power idle state whenever the QSTOP bit is set or the CPU enters low-power stop mode.

QADC stop:

- Disables the analog-to-digital converter, effectively turning off the analog circuit
- Aborts the conversion sequence in progress
- Makes the Data Direction Register (DDRQA), Port Data Registers (PORTQA and PORTQB), Control Registers (QACR2, QACR1, and QACR0) and the Status Registers (QASR1 and QASR0) read-only. Only the Module Configuration Register (QADCMCR) remains writable.
- Makes the RAM inaccessible, so that valid data cannot be read from RAM (result word table and CCW) or written to RAM (result word table and CCW)
- Resets QACR1, QACR2, QASR0, and QASR1
- Holds the QADC periodic/interval timer in reset

Because the bias currents to the analog circuit are turned off in stop mode, the QADC requires some recovery time ( $t_{SR}$ ) to stabilize the analog circuits.

## 19.6 Signals

The QADC uses the external pins shown in [Figure 19-2](#). There are eight channel/port pins that can support up to 18 channels when external multiplexing is used (including internal channels). All of the channel pins

**Queued Analog-to-Digital Converter (QADC)**

also have some general-purpose input or input/output functionality. In addition, there are also two analog reference pins and two analog submodule power pins.

The QADC has external trigger inputs and multiplexer outputs that are shared with some of the analog input pins.

**19.6.1 Port QA Pin Functions**

The four port QA pins can be used as analog inputs or as a bidirectional 4-bit digital input/output port.

*19.6.1.1 Port QA Analog Input Pins*

When used as analog inputs, the four port QA pins are referred to as AN[56:55, 53:52]. Due to the digital output drivers associated with port QA, the analog characteristics of port QA may be different from those of port QB.

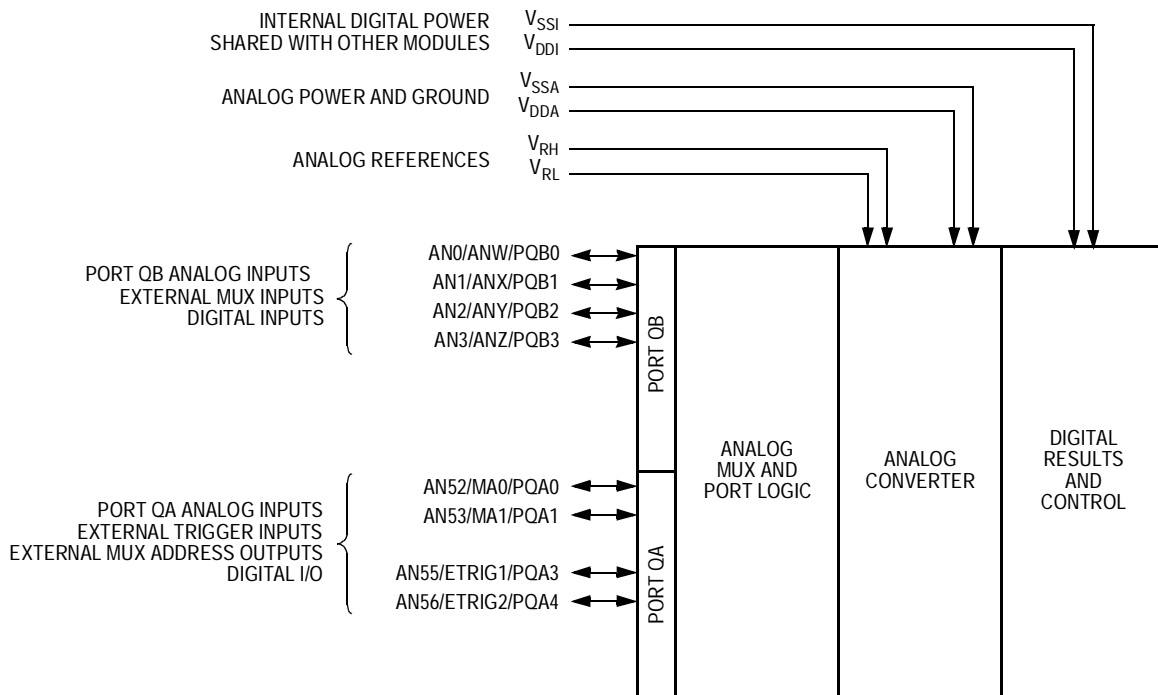

**Figure 19-2. QADC Input and Output Signals**



### 19.6.1.2 Port QA Digital Input/Output Pins

Port QA pins are referred to as PQA[4:3, 1:0] when used as a bidirectional 4-bit digital input/output port. These four pins may be used for general-purpose digital input signals or digital output signals.

Port QA pins are connected to a digital input synchronizer during reads and may be used as general-purpose digital inputs when the applied voltages meet high-voltage input ( $V_{IH}$ ) and low-voltage input ( $V_{IL}$ ) requirements.

Each port QA pin is configured as an input or output by programming the Port Data Direction Register (DDRQA). The digital input signal states are read from the port QA Data Register (PORTQA) when DDRQA specifies that the pins are inputs. The digital data in PORTQA is driven onto the port QA pins when the corresponding bits in DDRQA specify output. See [19.8.4 Port QA and QB Data Direction Register \(DDRQA and DDRQB\)](#).

## 19.6.2 Port QB Pin Functions

The four port QB pins can be used as analog inputs or as a 4-bit digital input-only port.

### 19.6.2.1 Port QB Analog Input Pins

When used as analog inputs, the four port QB pins are referred to as AN[3:0]. Because port QB functions as analog and digital input only, the analog characteristics may be different from those of port QA.

### 19.6.2.2 Port QB Digital Input Pins

Port QB pins are referred to as PQB[3:0] when used as a 4-bit digital input/output port. In addition to functioning as analog input pins, the port QB pins are also connected to the input of a synchronizer during reads and may be used as general-purpose digital inputs when the applied voltages meet  $V_{IH}$  and  $V_{IL}$  requirements.

## Queued Analog-to-Digital Converter (QADC)

Each port QB pin is configured as an input or output by programming the Port Data Direction Register (DDRQB). The digital input signal states are read from the port QB Data Register (PORTQB) when DDRQB specifies that the pins are inputs. The digital data in PORTQB is driven onto the port QB pins when the corresponding bits in DDRQB specify output. See [19.8.4 Port QA and QB Data Direction Register \(DDRQA and DDRQB\)](#).

### 19.6.3 External Trigger Input Pins

The QADC has two external trigger pins, ETRIG2 and ETRIG1. Each external trigger input is associated with one of the scan queues, queue 1 or queue 2. The assignment of ETRIG[2:1] to a queue is made by the TRG bit in QADC Control Register 0 (QACR0). When TRG = 0, ETRIG1 triggers queue 1 and ETRIG2 triggers queue 2. When TRG = 1, ETRIG1 triggers queue 2 and ETRIG2 triggers queue 1. See [19.8.5 Control Registers](#).

### 19.6.4 Multiplexed Address Output Pins

In non-multiplexed mode, the QADC analog input pins are connected to an internal multiplexer which routes the analog signals into the internal A/D converter.

In externally multiplexed mode, the QADC allows automatic channel selection through up to four external 4-to-1 multiplexer chips. The QADC provides a 2-bit multiplexed address output to the external multiplexer chips to allow selection of one of four inputs. The multiplexed address output signals, MA1 and MA0, can be used as multiplexed address output bits or as general-purpose I/O when external multiplexed mode is not being used.

MA[1:0] are used as the address inputs for up to four 4-channel multiplexer chips. Because the MA[1:0] pins are digital outputs in multiplexed mode, the state of their corresponding data direction bits in DDRQA is ignored.

### 19.6.5 Multiplexed Analog Input Pins

In external multiplexed mode, four of the port QB pins are redefined to each represent four analog input channels. See [Table 19-1](#).

**Table 19-1. Multiplexed Analog Input Channels**

Multiplexed Analog Input	Channels
ANw	Even numbered channels from 0 to 6
ANx	Odd numbered channels from 1 to 7
ANy	Even numbered channels from 16 to 22
ANz	Odd numbered channels from 17 to 23

### 19.6.6 Voltage Reference Pins

$V_{RH}$  and  $V_{RL}$  are the dedicated input pins for the high and low reference voltages. Separating the reference inputs from the power supply pins allows for additional external filtering, which increases reference voltage precision and stability, and subsequently contributes to a higher degree of conversion accuracy.

**NOTE:**  $V_{RH}$  and  $V_{RL}$  must be set to  $V_{DDA}$  and  $V_{SSA}$  potential, respectively.

### 19.6.7 Dedicated Analog Supply Pins

The  $V_{DDA}$  and  $V_{SSA}$  pins supply power to the analog subsystems of the QADC module. Dedicated power is required to isolate the sensitive analog circuitry from the normal levels of noise present on the digital power supply.

### 19.6.8 Dedicated Digital I/O Port Supply Pin

$V_{DDH}$  provides 5-V power to the digital I/O functions of QADC port QA and port QB. This allows those pins to tolerate 5 volts when configured as inputs and drive 5 volts when configured as outputs.

**Queued Analog-to-Digital Converter (QADC)**
**19.7 Memory Map**

The QADC occupies 1 Kbyte, or 512 half-word (16-bit) entries, of address space. Ten half-word registers are control, port, and status registers, 64 half-word entries are the CCW table, and 64 half-word entries are the result table which occupies 192 half-word address locations because the result data is readable in three data alignment formats. **Table 19-2** is the QADC memory map.

**Table 19-2. QADC Memory Map**

Address	MSB	LSB	Access <sup>(1)</sup>
0x00ca_0000	QADC Module Configuration Register (QADCMCR)		S
0x00ca_0002	QADC Test Register (QADCTEST) <sup>(2)</sup>		S
0x00ca_0004	Reserved <sup>(3)</sup>		—
0x00ca_0006	Port QA Data Register (PORTQA)	Port QB Data Register (PORTQB)	S/U
0x00ca_0008	Port QA Data Direction Register (DDRQA)	Port QB Data Direction Register (DDRQB)	S/U
0x00ca_000a	QADC Control Register 0 (QACR0)		S/U
0x00ca_000c	QADC Control Register 1 (QACR1)		S/U
0x00ca_000e	QADC Control Register 2 (QACR2)		S/U
0x00ca_0010	QADC Status Register 0 (QASR0)		S/U
0x00ca_0012	QADC Status Register 1 (QASR1)		S/U
0x00ca_0014– 0x00ca_01fe	Reserved <sup>(3)</sup>		—
0x00ca_0200– 0x00ca_027e	Conversion Command Word Table (CCW)		S/U
0x00ca_0280– 0x00ca_02fe	Right Justified, Unsigned Result Register (RJURR)		S/U
0x00ca_0300– 0x00ca_037e	Left Justified, Signed Result Register (LJSRR)		S/U
0x00ca_0380– 0x00ca_03fe	Left Justified, Unsigned Result Register (LJURR)		S/U

1. S = CPU supervisor mode access only. S/U = CPU supervisor or user mode access. User mode accesses to supervisor only addresses have no effect and result in a cycle termination transfer error.
2. Access results in the module generating an access termination transfer error if not in test mode.
3. Read/writes have no effect and the access terminates with a transfer error exception.

## 19.8 Register Descriptions

This subsection describes the QADC registers.

### 19.8.1 QADC Module Configuration Register (QADCMCR)

QADCMCR contains bits that control QADC debug and stop modes and determines the privilege level required to access most registers.

Address: 0x00ca\_0000 and 0x00ca\_0001

	Bit 15	14	13	12	11	10	9	Bit 8
Read:	QSTOP	QDBG	0	0	0	0	0	0
Write:								
Reset:	0	0	0	0	0	0	0	0
	Bit 7	6	5	4	3	2	1	Bit 0
Read:	SUPV	0	0	0	0	0	0	0
Write:								
Reset:	1	0	0	0	0	0	0	0

= Writes have no effect and the access terminates without a transfer error exception.

**Figure 19-3. QADC Module Configuration Register (QADCMCR)**

**QSTOP** — Stop Enable Bit

- 1 = Force QADC to idle state.
- 0 = QADC operates normally.

**QDBG** — Debug Enable Bit

- 1 = Finish any conversion in progress, then freeze in debug mode
- 0 = QADC operates normally.

**SUPV** — Supervisor/Unrestricted Data Space Bit

- 1 = All QADC registers are accessible in supervisor mode only; user mode accesses have no effect and result in a cycle termination error.
- 0 = Only QADCMCR and QADCTEST require supervisor mode access; access to all other QADC registers is unrestricted

**Queued Analog-to-Digital Converter (QADC)**

**19.8.2 QADC Test Register (QADCTEST)**

QADCTEST is used only during factory testing of the MCU. Attempts to access this register outside of factory test mode will result in access privilege violation.

Address: 0x00ca\_0002 and 0x00ca\_0003

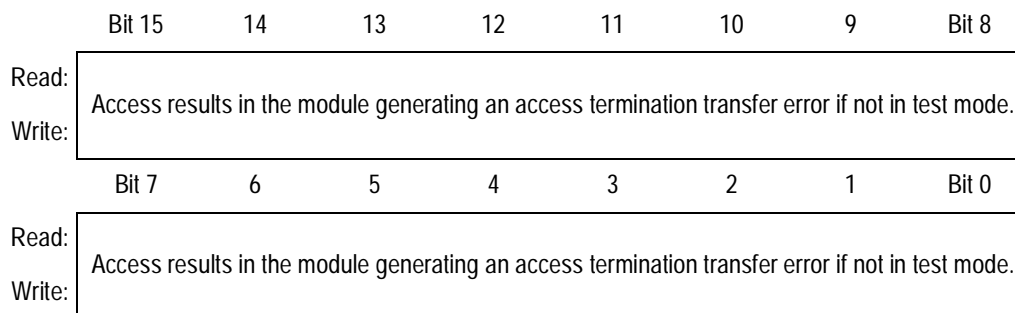

**Figure 19-4. QADC Test Register (QADCTEST)**

**19.8.3 Port Data Registers (PORTQA and PORTQB)**

QADC ports QA and QB are accessed through two 8-bit port data registers (PORTQA and PORTQB).

Port QA pins are referred to as PQA[4:3, 1:0] when used as a bidirectional, 4-bit, input/output port. Port QA can also be used for analog inputs (AN[56:55, 53:52]), external trigger inputs (ETRIG[2:1]), and external multiplexer address outputs (MA[1:0]).

Port QB pins are referred to as PQB[3:0] when used as a 4-bit, digital input-only port. Port QB can also be used for non-multiplexed (AN[3:0]) and multiplexed (ANz, ANy, ANx, ANw) analog inputs.

PORTQA and PORTQB are not initialized by reset.

Address: 0x00ca\_0006

	Bit 7	6	5	4	3	2	1	Bit 0
Read:	0	0	0	PQA4	PQA3	0	PQA1	PQA0
Write:								
Reset:	0	0	0	P	P	0	P	P

= Writes have no effect and the access terminates without a transfer error exception.

P = Current pin state if DDR is input; otherwise, undefined

Analog Channel:	AN56	AN55	AN53	AN52
Muxed Address Outputs:			MA1	MA0
External Trigger Inputs:	ETRIG2	ETRIG1		

**Figure 19-5. QADC Port QA Data Register (PORTQA)**

Address: 0x00ca\_0007

	Bit 7	6	5	4	3	2	1	Bit 0
Read:	0	0	0	0	PQB3	PQB2	PQB1	PQB0
Write:								
Reset:	0	0	0	0	P	P	P	P

= Writes have no effect and the access terminates without a transfer error exception.

P = Current pin state if DDR is input; otherwise, undefined

Analog Channel:	AN3	AN2	AN1	AN0
Muxed Analog Inputs:	AN2	ANy	ANx	ANw

**Figure 19-6. QADC Port QB Data Register (PORTQB)**

Read: Anytime

Write: Anytime except during stop mode

#### 19.8.4 Port QA and QB Data Direction Register (DDRQA and DDRQB)

The Port QA and QB Data Direction Register (DDRQA and DDRQB) are associated with port QA and QB digital I/O pins. Setting a bit in these registers configures the corresponding pin as an output. Clearing a bit in these registers configures the corresponding pin as an input. During QADC initialization, port QA and QB pins that will be used as direct or multiplexed analog inputs must have their corresponding data direction register bits cleared. When a port QA or QB pin that is programmed as an output is selected for analog conversion, the voltage sampled is that of the output digital driver as influenced by the load.

When the MUX (externally multiplexed) bit is set in QACR0, the data direction register settings are ignored for the bits corresponding to PQA[1:0], the two multiplexed address (MA[1:0]) output pins. The MA[1:0] pins are forced to be digital outputs, regardless of their data direction setting, and the multiplexed address outputs are driven. The data returned during a port data register read is the value of the MA[1:0] pins, regardless of their data direction setting.

Similarly, when the external trigger pins are assigned to port pins and external trigger queue operating mode is selected, the data direction setting for the corresponding pins, PQA3 and/or PQA4, is ignored. The port pins are forced to be digital inputs for ETRIG1 and/or ETRIG2. The data returned during a port data register read is the value of ETRIG[2:1] pins, regardless of their data direction setting.

**NOTE:** *Use caution when mixing digital and analog inputs. They should be isolated as much as possible. Rise and fall times should be as large as possible to minimize ac coupling effects.*



Address: 0x00ca\_0008 and 0x00ca\_0009

	Bit 15	14	13	12	11	10	9	Bit 8
Read:	0	0	0	DDQA4	DDQA3	0	DDQA1	DDQA0
Write:								
Reset:	0	0	0	0	0	0	0	0
	Bit 7	6	5	4	3	2	1	Bit 0
Read:	0	0	0	0	DDQB3	DDQB2	DDQB1	DDQB0
Write:								
Reset:	0	0	0	0	0	0	0	0

= Writes have no effect and the access terminates without a transfer error exception.

**Figure 19-7. QADC Port QA Data Direction Register (DDRQA) and Port QB Data Direction Register (DDRQB)**

Read: Anytime

Write: Anytime except during stop mode

**Queued Analog-to-Digital Converter (QADC)**

**19.8.5 Control Registers**

This subsection describes the QADC control registers.

*19.8.5.1 QADC Control Register 0 (QACR0)*

QADC Control Register 0 (QACR0) establishes the QADC sampling clock (QCLK) with prescaler parameter fields and defines whether external multiplexing is enabled. Typically, these bits are written once when the QADC is initialized and not changed thereafter.

Address: 0x00ca\_000a and 0x00ca\_000b

	Bit 15	14	13	12	11	10	9	Bit 8
Read:	MUX	0	0	TRG	0	0	0	0
Write:								
Reset:	0	0	0	0	0	0	0	0
	Bit 7	6	5	4	3	2	1	Bit 0
Read:	0	QPR6	QPR5	QPR4	QPR3	QPR2	QPR1	QPR0
Write:								
Reset:	0	0	0	1	0	0	1	1

= Writes have no effect and the access terminates without a transfer error exception.

**Figure 19-8. QADC Control Register 0 (QACR0)**

Read: Anytime

Write: Anytime except during stop mode

MUX — Externally Multiplexed Mode Bit

The MUX bit configures the QADC for operation in externally multiplexed mode, which affects the interpretation of the channel numbers and forces the MA[1:0] pins to be outputs.

1 = Externally multiplexed, up to 18 possible channels

0 = Internally multiplexed, up to 8 possible channels

## TRG — Trigger Assignment Bit

The TRG bit determines the queue assignment of the ETRIG[2:1] pins.

- 1 = ETRIG1 triggers queue 2; ETRIG2 triggers queue 1.
- 0 = ETRIG1 triggers queue 1; ETRIG2 triggers queue 2.

## QPR[6:0] — Prescaler Clock Divider Bits

The read/write QPR[6:0] bits select the system clock divisor to generate the QADC clock as [Table 19-3](#) shows. The resulting QADC clock rate can be given as:

$$f_{\text{QCLK}} = \frac{f_{\text{SYS}}}{\text{QPR}[6:0] + 1}$$

where:

$$1 \leq \text{QPR}[6:0] \leq 127.$$

If QPR[6:0] = 0, then the QPR register field value is read as a 1 and the prescaler divisor is 2.

The prescaler should be selected so that the QADC clock rate is within the required fQCLK range. See [Table 23-8. QADC Conversion Specifications \(Operating\)](#).

**Queued Analog-to-Digital Converter (QADC)**
**Table 19-3. Prescaler  $f_{SYS}$  Divide-by Values**

QPR[6:0]	$f_{SYS}$ Divisor	QPR[6:0]	$f_{SYS}$ Divisor	QPR[6:0]	$f_{SYS}$ Divisor	QPR[6:0]	$f_{SYS}$ Divisor
0000000	2	0100000	33	1000000	65	1100000	97
0000001	2	0100001	34	1000001	66	1100001	98
0000010	3	0100010	35	1000010	67	1100010	99
0000011	4	0100011	36	1000011	68	1100011	100
0000100	5	0100100	37	1000100	69	1100100	101
0000101	6	0100101	38	1000101	70	1100101	102
0000110	7	0100110	39	1000110	71	1100110	103
0000111	8	0100111	40	1000111	72	1100111	104
0001000	9	0101000	41	1001000	73	1101000	105
0001001	10	0101001	42	1001001	74	1101001	106
0001010	11	0101010	43	1001010	75	1101010	107
0001011	12	0101011	44	1001011	76	1101011	108
0001100	13	0101100	45	1001100	77	1101100	109
0001101	14	0101101	46	1001101	78	1101101	110
0001110	15	0101110	47	1001110	79	1101110	111
0001111	16	0101111	48	1001111	80	1101111	112
0010000	17	0110000	49	1010000	81	1110000	113
0010001	18	0110001	50	1010001	82	1110001	114
0010010	19	0110010	51	1010010	83	1110010	115
0010011	20	0110011	52	1010011	84	1110011	116
0010100	21	0110100	53	1010100	85	1110100	117
0010101	22	0110101	54	1010101	86	1110101	118
0010110	23	0110110	55	1010110	87	1110110	119
0010111	24	0110111	56	1010111	88	1110111	120
0011000	25	0111000	57	1011000	89	1111000	121
0011001	26	0111001	58	1011001	90	1111001	122
0011010	27	0111010	59	1011010	91	1111010	123
0011011	28	0111011	60	1011011	92	1111011	124
0011100	29	0111100	61	1011100	93	1111100	125
0011101	30	0111101	62	1011101	94	1111101	126
0011110	31	0111110	63	1011110	95	1111110	127
0011111	32	0111111	64	1011111	96	1111111	128

19.8.5.2 QADC Control Register 1 (QACR1)

QADC Control Register 1 (QACR1) is the mode control register for queue 1. This register governs queue operating mode and the use of completion and/or pause interrupts. Typically, these bits are written once when the QADC is initialized and not changed thereafter.

Stop mode resets this register (\$0000).

Address: 0x00ca\_000c and 0x00ca\_000d

	Bit 15	14	13	12	11	10	9	Bit 8
Read:	CIE1	PIE1	0	MQ112	MQ111	MQ110	MQ19	MQ18
Write:			SSE1					
Reset:	0	0	0	0	0	0	0	0
	Bit 7	6	5	4	3	2	1	Bit 0
Read:	0	0	0	0	0	0	0	0
Write:								
Reset:	0	0	0	0	0	0	0	0

= Writes have no effect and the access terminates without a transfer error exception.

**Figure 19-9. QADC Control Register 1 (QACR1)**

Read: Anytime

Write: Anytime except during stop mode

CIE1 — Queue 1 Completion Interrupt Enable Bit

CIE1 enables an interrupt request upon completion of queue 1. The interrupt request is initiated when the conversion is complete for the last CCW in queue 1.

1 = Enable queue 1 completion interrupt.

0 = Disable queue 1 completion interrupt.

**Queued Analog-to-Digital Converter (QADC)**
**PIE1 — Queue 1 Pause Interrupt Enable Bit**

PIE1 enables an interrupt request when queue 1 enters the pause state. The interrupt request is initiated when conversion is complete for a CCW that has the pause bit set.

1 = Enable the queue 1 pause interrupt.

0 = Disable the queue 1 pause interrupt.

**SSE1 — Queue 1 Single-Scan Enable Bit**

SSE1 enables a single-scan of queue 1 after a trigger event occurs. SSE1 may be set during the same write cycle that sets the MQ1 bits for one of the single-scan queue operating modes. The single-scan enable bit can be written to 1 or 0, but is always read as a 0, unless the QADC is in test mode. The QADC clears SSE1 when the single-scan is complete.

1 = Allow a trigger event to start queue 1 in a single-scan mode.

0 = Trigger events are ignored for queue 1 single-scan modes.

**MQ1[12:8] — Queue 1 Operating Mode Field**

The MQ1 field selects the operating mode for queue 1.

**Table 19-4** shows the bits in the MQ1 field which enable different queue 1 operating modes.

**Table 19-4. Queue 1 Operating Modes**

MQ1[12:8]	Operating Mode
00000	Disabled mode, conversions do not occur
00001	Software-triggered single-scan mode (started with SSE1)
00010	External-trigger rising-edge single-scan mode
00011	External-trigger falling-edge single-scan mode
00100	Interval timer single-scan mode: time = QCLK period $\times 2^7$
00101	Interval timer single-scan mode: time = QCLK period $\times 2^8$
00110	Interval timer single-scan mode: time = QCLK period $\times 2^9$
00111	Interval timer single-scan mode: time = QCLK period $\times 2^{10}$
01000	Interval timer single-scan mode: time = QCLK period $\times 2^{11}$
01001	Interval timer single-scan mode: time = QCLK period $\times 2^{12}$

**Table 19-4. Queue 1 Operating Modes (Continued)**

MQ1[12:8]	Operating Mode
01010	Interval timer single-scan mode: time = QCLK period $\times 2^{13}$
01011	Interval timer single-scan mode: time = QCLK period $\times 2^{14}$
01100	Interval timer single-scan mode: time = QCLK period $\times 2^{15}$
01101	Interval timer single-scan mode: time = QCLK period $\times 2^{16}$
01110	Interval timer single-scan mode: time = QCLK period $\times 2^{17}$
01111	Externally gated single-scan mode (started with SSE1)
10000	Reserved mode
10001	Software-triggered continuous-scan mode
10010	External-trigger rising-edge continuous-scan mode
10011	External-trigger falling-edge continuous-scan mode
10100	Periodic timer continuous-scan mode: time = QCLK period $\times 2^7$
10101	Periodic timer continuous-scan mode: time = QCLK period $\times 2^8$
10110	Periodic timer continuous-scan mode: time = QCLK period $\times 2^9$
10111	Periodic timer continuous-scan mode: time = QCLK period $\times 2^{10}$
11000	Periodic timer continuous-scan mode: time = QCLK period $\times 2^{11}$
11001	Periodic timer continuous-scan mode: time = QCLK period $\times 2^{12}$
11010	Periodic timer continuous-scan mode: time = QCLK period $\times 2^{13}$
11011	Periodic timer continuous-scan mode: time = QCLK period $\times 2^{14}$
11100	Periodic timer continuous-scan mode: time = QCLK period $\times 2^{15}$
11101	Periodic timer continuous-scan mode: time = QCLK period $\times 2^{16}$
11110	Periodic timer continuous-scan mode: time = QCLK period $\times 2^{17}$
11111	Externally gated continuous-scan mode

**Queued Analog-to-Digital Converter (QADC)**

19.8.5.3 QADC Control Register 2 (QACR2)

QADC Control Register 2 (QACR2) is the mode control register for queue 2. This register governs queue operating mode and the use of completion and/or pause interrupts. Typically, these bits are written once when the QADC is initialized and not changed thereafter.

Stop mode resets this register (\$007f).

Address: 0x00ca\_000e and 0x00ca\_000f

	Bit 15	14	13	12	11	10	9	Bit 8
Read:	CIE2	PIE2	0	MQ212	MQ211	MQ210	MQ29	MQ28
Write:			SSE2					
Reset:	0	0	0	0	0	0	0	0
	Bit 7	6	5	4	3	2	1	Bit 0
Read:	RESUME	BQ26	BQ25	BQ24	BQ23	BQ22	BQ21	BQ20
Write:								
Reset:	0	1	1	1	1	1	1	1

**Figure 19-10. QADC Control Register 2 (QACR2)**

Read: Anytime

Write: Anytime except during stop mode

CIE2 — Queue 2 Completion Software Interrupt Enable Bit

CIE2 enables an interrupt request upon completion of queue 2. The interrupt request is initiated when the conversion is complete for the last CCW in queue 2.

- 1 = Enable queue 2 completion interrupts.
- 0 = Disable queue 2 completion interrupts.



**PIE2 — Queue 2 Pause Software Interrupt Enable Bit**

PIE2 enables an interrupt request when queue 2 enters the pause state. The interrupt request is initiated when conversion is complete for a CCW that has the pause bit set.

1 = Enable the queue 2 pause interrupt.

0 = Disable the queue 2 pause interrupt.

**SSE2 — Queue 2 Single-Scan Enable Bit**

SSE2 enables a single-scan of queue 2 after a trigger event occurs. SSE2 may be set during the same write cycle that sets the MQ2 bits for one of the single-scan queue operating modes. The single-scan enable bit can be written to 1 or 0, but is always read as a 0, unless the QADC is in test mode. The QADC clears SSE2 when the single-scan is complete.

1 = Allow a trigger event to start queue 2 in a single-scan mode.

0 = Trigger events are ignored for queue 2 single-scan modes.

**MQ2[12:8] — Queue 2 Operating Mode Field**

The MQ2 field selects the operating mode for queue 2.

**Table 19-5** shows the bits in the MQ2 field which enable different queue 2 operating modes.

**Table 19-5. Queue 2 Operating Modes**

MQ2[12:8]	Operating Modes
00000	Disabled mode, conversions do not occur
00001	Software triggered single-scan mode (started with SSE2)
00010	Externally triggered rising edge single-scan mode
00011	Externally triggered falling edge single-scan mode
00100	Interval timer single-scan mode: time = QCLK period x 2 <sup>7</sup>
00101	Interval timer single-scan mode: time = QCLK period x 2 <sup>8</sup>
00110	Interval timer single-scan mode: time = QCLK period x 2 <sup>9</sup>
00111	Interval timer single-scan mode: time = QCLK period x 2 <sup>10</sup>
01000	Interval timer single-scan mode: time = QCLK period x 2 <sup>11</sup>
01001	Interval timer single-scan mode: time = QCLK period x 2 <sup>12</sup>

**Table 19-5. Queue 2 Operating Modes (Continued)**

MQ2[12:8]	Operating Modes
01010	Interval timer single-scan mode: time = QCLK period x 2 <sup>13</sup>
01011	Interval timer single-scan mode: time = QCLK period x 2 <sup>14</sup>
01100	Interval timer single-scan mode: time = QCLK period x 2 <sup>15</sup>
01101	Interval timer single-scan mode: time = QCLK period x 2 <sup>16</sup>
01110	Interval timer single-scan mode: time = QCLK period x 2 <sup>17</sup>
01111	Reserved mode
10000	Reserved mode
10001	Software triggered continuous-scan mode
10010	Externally triggered rising edge continuous-scan mode
10011	Externally triggered falling edge continuous-scan mode
10100	Periodic timer continuous-scan mode: time = QCLK period x 2 <sup>7</sup>
10101	Periodic timer continuous-scan mode: time = QCLK period x 2 <sup>8</sup>
10110	Periodic timer continuous-scan mode: time = QCLK period x 2 <sup>9</sup>
10111	Periodic timer continuous-scan mode: time = QCLK period x 2 <sup>10</sup>
11000	Periodic timer continuous-scan mode: time = QCLK period x 2 <sup>11</sup>
11001	Periodic timer continuous-scan mode: time = QCLK period x 2 <sup>12</sup>
11010	Periodic timer continuous-scan mode: time = QCLK period x 2 <sup>13</sup>
11011	Periodic timer continuous-scan mode: time = QCLK period x 2 <sup>14</sup>
11100	Periodic timer continuous-scan mode: time = QCLK period x 2 <sup>15</sup>
11101	Periodic timer continuous-scan mode: time = QCLK period x 2 <sup>16</sup>
11110	Periodic timer continuous-scan mode: time = QCLK period x 2 <sup>17</sup>
11111	Reserved mode

## RESUME — Queue 2 Resume Bit

RESUME selects the resumption point for queue 2 after its operation is suspended due to a queue 1 trigger event. If RESUME is changed during the execution of queue 2, the change is not recognized until an end-of-queue condition is reached or the operating mode of queue 2 is changed.

The primary reason for selecting re-execution of the entire queue or subqueue is to guarantee that all samples are taken consecutively in one scan (coherency).

When subqueues are not used, queue 2 execution restarts after suspension with the first CCW in queue 2. When a pause has previously occurred in queue 2 execution, queue execution restarts after suspension with the first CCW in the current subqueue.

A subqueue is considered to be a stand-alone sequence of conversions. Once a pause flag has been set to report subqueue completion, that subqueue is not repeated until all CCWs in queue 2 are executed.

An example of using the RESUME bit is when the frequency of queue 1 trigger events prohibit queue 2 completion. If the rate of queue 1 execution is too high, it is best for queue 2 execution to continue with the CCW that was being converted when queue 2 was suspended. This allows queue 2 to eventually complete execution.

- 1 = After suspension, begin execution with the aborted CCW in queue 2.
- 0 = After suspension, begin execution with the first CCW of queue 2 or the current subqueue of queue 2.

## BQ2[6:0] — Beginning of Queue 2 Field

BQ2[6:0] denotes the CCW location where queue 2 begins. This allows the length of queue 1 and queue 2 to vary. The BQ2 field also serves as an end-of-queue condition for queue 1.

The beginning of queue 2 is defined by programming the BQ2 field in QACR2. BQ2 is usually set before or at the same time as the queue operating mode for queue 2 is selected. If  $BQ2[6:0] \geq 64$ , queue 2 has no entries, the entire CCW table is dedicated to queue 1, and CCW63 is the end-of-queue 1. If BQ2[6:0] is 0, the entire CCW table is dedicated to queue 2. A special case occurs when an operating mode

**Queued Analog-to-Digital Converter (QADC)**

is selected for queue 1 and a trigger event occurs for queue 1 with BQ2 set to 0. Queue 1 execution starts momentarily, but is terminated after CCW0 is read. No conversions occur.

The BQ2[6:0] pointer may be changed dynamically to alternate between queue 2 scan sequences. A change in BQ2 after queue 2 has begun or when queue 2 has a trigger pending does not affect queue 2 until it is started again. For example, two scan sequences could be defined as follows: The first sequence starts at CCW10, with a pause after CCW11 and an end of queue (EOQ) programmed in CCW15; the second sequence starts at CCW16, with a pause after CCW17 and an EOQ programmed in CCW39.

With BQ2[6:0] set to CCW10 and the continuous-scan mode selected, queue execution begins. When the pause is encountered in CCW11, an interrupt service routine can retarget BQ2[6:0] to CCW16. When the end-of-queue is recognized in CCW15, an internal retrigger event is generated and execution restarts at CCW16. When the pause software interrupt occurs again, BQ2 can be changed back to CCW10. After the end-of-queue is recognized in CCW39, an internal retrigger event is created and execution now restarts at CCW10.

If BQ2[6:0] is changed while queue 1 is active, the effect of BQ2[6:0] as an end-of-queue indication for queue 1 is immediate. However, beware of the risk of losing the end-of-queue 1 when changing BQ2[6:0]. Using EOQ (channel 63) to end queue 1 is recommended.

**NOTE:** *If BQ2[6:0] was assigned to the CCW that queue 1 is currently working on, then that conversion is completed before the change to BQ2[6:0] takes effect.*

Each time a CCW is read for queue 1, the CCW location is compared with the current value of the BQ2[6:0] pointer to detect a possible end-of-queue condition. For example, if BQ2[6:0] is changed to CCW3 while queue 1 is converting CCW2, queue 1 is terminated after the conversion is completed. However, if BQ2[6:0] is changed to CCW1 while queue 1 is converting CCW2, the QADC would not recognize a BQ2[6:0] end-of-queue condition until queue 1 execution reached CCW1 again, presumably on the next pass through the queue.

## 19.8.6 Status Registers

This subsection describes the QADC status registers.

### 19.8.6.1 QADC Status Register 0 (QASR0)

QADC Status Register 0 (QASR0) contains information about the state of each queue and the current A/D conversion.

Stop mode resets this register (\$0000).

Address: 0x00ca\_0010 and 0x00ca\_0011

	Bit 15	14	13	12	11	10	9	Bit 8
Read:	CF1	PF1	CF2	PF2	TOR1	TOR2	QS9	QS8
Write:								
Reset:	0	0	0	0	0	0	0	0
	Bit 7	6	5	4	3	2	1	Bit 0
Read:	QS7	QS6	CWP5	CWP4	CWP3	CWP2	CWP1	CWP0
Write:								
Reset:	0	0	0	0	0	0	0	0

= Writes have no effect and the access terminates without a transfer error exception.

**Figure 19-11. QADC Status Register 0 (QASR0)**

Read: Anytime

Write:

For flag bits (CF1, PF1, CF2, PF2, TOR1, TOR2): Writing a 1 has no effect, write a 0 to clear.

For QS[9:6] and CWP: Writes have no effect.

**CF1** — Queue 1 Completion Flag

CF1 indicates that a queue 1 scan has been completed. CF1 is set by the QADC when the input channel sample requested by the last CCW in queue 1 is converted, and the result is stored in the result table.

The end-of-queue 1 is identified when execution is complete on the CCW in the location prior to that pointed to by BQ2, when the current CCW contains the end-of-queue code (channel 63) instead of a valid channel number, or when the currently completed CCW is in the last location of the CCW RAM.

When CF1 is set and queue 1 completion interrupts are enabled (CIE1 = 1), the QADC requests an interrupt. The interrupt request is cleared when a 0 is written to the CF1 bit after it has been read as a 1. Once set, CF1 can be cleared only by a reset or by writing a 0 to it.

CF1 is updated by the QADC regardless of whether the corresponding interrupt is enabled. This allows polled recognition of queue 1 scan completion.

#### PF1 — Queue 1 Pause Flag

PF1 indicates that a queue 1 scan has reached a pause. PF1 is set by the QADC when the current queue 1 CCW has the pause bit set, the selected input channel has been converted, and the result has been stored in the result table.

Once PF1 is set, the queue enters the paused state and waits for a trigger event to allow queue execution to continue. However, a special case occurs when the CCW with the pause bit set is the last CCW in a queue; queue execution is complete. The queue status becomes idle, not paused, and both the pause and completion flags are set.

Another special case occurs when queue 1 is operating in software-initiated single-scan or continuous-scan mode and a CCW pause bit is set. The QADC will set PF1 and will also automatically generate a retrigger event that restarts execution after two QCLK cycles. Pause mode is never entered.

When PF1 is set and interrupts are enabled (PIE1 = 1), the QADC requests an interrupt. The interrupt request is cleared when a 0 is written to PF1, after it has been read as a 1. Once set, PF1 can be cleared only by reset or by writing a 0 to it.

In externally gated single-scan and continuous-scan mode, the behavior of PF1 has been redefined. When the gate closes before the end-of-queue 1 is reached, PF1 is set to indicate that an incomplete scan has occurred. In single-scan mode, a resultant interrupt can be

used to determine if queue 1 should be enabled again. In either externally gated mode, setting PF1 indicates that the results for queue 1 have not been collected during one scan (coherently).

**NOTE:** *If a set CCW pause bit is encountered in either externally gated mode, the pause flag will not set, and execution continues without pausing. This has allowed for the modified behavior of PF1 in the externally gated modes.*

PF1 is maintained by the QADC regardless of whether the corresponding interrupt is enabled. PF1 may be polled to determine if the QADC has reached a pause in scanning a queue.

1 = Queue 1 has reached a pause or gate closed before end-of-queue in gated mode.

0 = Queue 1 has not reached a pause or gate has not closed before end-of-queue in gated mode.

See [Table 19-6](#) for a summary of CCW pause bit response in all scan modes.

**Table 19-6. CCW Pause Bit Response**

Scan Mode	Queue Operation	PF Asserts?
Externally triggered single-scan	Pauses	Yes
Externally triggered continuous-scan	Pauses	Yes
Interval timer trigger single-scan	Pauses	Yes
Interval timer continuous-scan	Pauses	Yes
Software-initiated single-scan	Continues	Yes
Software-initiated continuous-scan	Continues	Yes
Externally gated single-scan	Continues	No
Externally gated continuous-scan	Continues	No

#### CF2 — Queue 2 Completion Flag

CF2 indicates that a queue 2 scan has been completed. CF2 is set by the QADC when the input channel sample requested by the last CCW in queue 2 is converted, and the result is stored in the result table.

The end-of-queue 2 is identified when the current CCW contains an end-of-queue code (channel 63) instead of a valid channel number

## Queued Analog-to-Digital Converter (QADC)

or when the currently completed CCW is in the last location of the CCW RAM.

When CF2 is set and queue 2 completion interrupts are enabled (CIE2 = 1), the QADC requests an interrupt. The interrupt request is cleared when a 0 is written to the CF2 bit after it has been read as a 1. Once set, CF2 can be cleared only by a reset or by writing a 0 to it. CF2 is updated by the QADC regardless of whether the corresponding interrupt is enabled. This allows polled recognition of queue 2 scan completion.

## PF2 — Queue 2 Pause Flag

PF2 indicates that a queue 2 scan has reached a pause. PF2 is set by the QADC when the current queue 2 CCW has the pause bit set, the selected input channel has been converted, and the result has been stored in the result table.

Once PF2 is set, the queue enters the paused state and waits for a trigger event to allow queue execution to continue. However, a special case occurs when the CCW with the pause bit set is the last CCW in a queue: Queue execution is complete. The queue status becomes idle, not paused, and both the pause and completion flags are set.

Another special case occurs when queue 2 is operating in software-initiated single-scan or continuous-scan mode and a CCW pause bit is set. The QADC will set PF2 and will also automatically generate a retrigger event that restarts execution after two QCLK cycles. Pause mode is never entered.

When PF2 is set and interrupts are enabled (PIE2 = 1), the QADC requests an interrupt. The interrupt request is cleared when a 0 is written to PF2, after it has been read as a 1. Once set, PF2 can be cleared only by a reset or by writing a 0 to it.

PF2 is maintained by the QADC regardless of whether the corresponding interrupt is enabled. PF2 may be polled to determine if the QADC has reached a pause in scanning a queue.

1 = Queue 2 has reached a pause.

0 = Queue 2 has not reached a pause.

See [Table 19-6](#) for a summary of pause response in all scan modes.



### TOR1 — Queue 1 Trigger Overrun Flag

TOR1 indicates that an unexpected trigger event has occurred for queue 1. TOR1 can be set only while queue 1 is in the active state.

A trigger event generated by a transition on the external trigger pin or by the periodic/interval timer may be captured as a trigger overrun. TOR1 cannot be set when the software-initiated single-scan mode or the software-initiated continuous-scan mode is selected.

TOR1 is set when a trigger event is received while a queue is executing and before the scan has completed or paused. TOR1 has no effect on queue execution.

After a trigger event has occurred for queue 1, and before the scan has completed or paused, additional queue 1 trigger events are not retained. Such trigger events are considered unexpected, and the QADC sets the TOR1 error status bit. An unexpected trigger event may denote a system overrun situation.

In externally gated continuous-scan mode, the behavior of TOR1 has been redefined. In the case when queue 1 reaches an end-of-queue condition for the second time during an open gate, TOR1 is set. This is considered an overrun condition. In this case CF1 has been set for the first end-of-queue 1 condition and then TOR1 sets for the second end-of-queue 1 condition. For TOR1 to set, CF2 must not be cleared before the second end-of-queue 1.

Once set, TOR1 is cleared only by a reset or by writing a 0 to it.

1 = At least one unexpected queue 1 trigger event has occurred or queue 1 reaches an end-of-queue condition for the second time in externally gated continuous scan.

0 = No unexpected queue 1 trigger events have occurred.

### TOR2 — Queue 2 Trigger Overrun Flag

TOR2 indicates that an unexpected trigger event has occurred for queue 2. TOR2 can be set when queue 2 is in the active, suspended, and trigger pending states.

The TOR2 trigger overrun can occur only when using an external trigger mode or a periodic/interval timer mode. Trigger overruns cannot occur when the software-initiated single-scan mode and the software-initiated continuous-scan mode are selected.

**Queued Analog-to-Digital Converter (QADC)**

TOR2 is set when a trigger event is received while queue 2 is executing, suspended, or a trigger is pending. TOR2 has no effect on queue execution. A trigger event that causes a trigger overrun is not retained since it is considered unexpected. An unexpected trigger event may be a system overrun situation.

Once set, TOR2 is cleared only by a reset or by writing a 0 to it.

- 1 = At least one unexpected queue 2 trigger event has occurred.
- 0 = No unexpected queue 2 trigger events have occurred.

**QS[9:6] — Queue Status Field**

The 4-bit read-only QS field indicates the current condition of queue 1 and queue 2. The five queue status conditions are:

- Idle
- Active
- Paused
- Suspended
- Trigger pending

The two most significant bits are associated primarily with queue 1, and the remaining two bits are associated with queue 2. Because the priority scheme between the two queues causes the status to be interlinked, the status bits must be considered as one 4-bit field.

**Table 19-7** shows the bits in the QS field and how they denote the status of queue 1 and queue 2.

**Table 19-7. Queue Status**

QS[9:6]	Queue 1/Queue 2 States
0000	Queue 1 idle, queue 2 idle
0001	Queue 1 idle, queue 2 paused
0010	Queue 1 idle, queue 2 active
0011	Queue 1 idle, queue 2 trigger pending
0100	Queue 1 paused, queue 2 idle
0101	Queue 1 paused, queue 2 paused
0110	Queue 1 paused, queue 2 active

**Table 19-7. Queue Status (Continued)**

QS[9:6]	Queue 1/Queue 2 States
0111	Queue 1 paused, queue 2 trigger pending
1000	Queue 1 active, queue 2 idle
1001	Queue 1 active, queue 2 paused
1010	Queue 1 active, queue 2 suspended
1011	Queue 1 active, queue 2 trigger pending
1100	Reserved
1101	Reserved
1110	Reserved
1111	Reserved

One or both queues may be in the idle state. When a queue is idle, CCWs are not being executed for that queue, the queue is not in the pause state, and no trigger is pending.

The idle state occurs when a queue is disabled, when a queue is in a reserved mode, or when a queue is in a valid queue operating mode awaiting a trigger event to initiate queue execution.

A queue is in the active state when a valid queue operating mode is selected, when the selected trigger event has occurred, or when the QADC is performing a conversion specified by a CCW from that queue.

Only one queue can be active at a time. One or both queues can be in the paused state. A queue is paused when the previous CCW executed from that queue had the pause bit set. The QADC does not execute any CCWs from the paused queue until a trigger event occurs. Consequently, the QADC can service queue 2 while queue 1 is paused.

Only queue 2 can be in the suspended state. When a trigger event occurs on queue 1 while queue 2 is executing, the current queue 2 conversion is aborted. The queue 2 status is reported as suspended. Queue 2 transitions back to the active state when queue 1 becomes idle or paused.

A trigger pending state is required because both queues cannot be active at the same time. The status of queue 2 is changed to trigger pending when a trigger event occurs for queue 2 while queue 1 is active. In the opposite case, when a trigger event occurs for queue 1 while queue 2 is active, queue 2 is aborted and the status is reported as queue 1 active, queue 2 suspended. So due to the priority scheme, only queue 2 can be in the trigger pending state.

Two transition cases cause the queue 2 status to be trigger pending before queue 2 is shown to be in the active state. When queue 1 is active and there is a trigger pending on queue 2, after queue 1 completes or pauses, queue 2 continues to be in the trigger pending state for a few clock cycles. The fleeting status conditions are:

- Queue 1 idle with queue 2 trigger pending
- Queue 1 paused with queue 2 trigger pending

**Figure 19-12** displays the status conditions of the QS field as the QADC goes through the transition from queue 1 active to queue 2 active.

The queue status field is affected by QADC stop mode. Because all of the analog logic and control registers are reset, the queue status field is reset to queue 1 idle, queue 2 idle.

During debug mode, the queue status field is not modified. The queue status field retains the status it held prior to freezing. As a result, the queue status can show queue 1 active, queue 2 idle, even though neither queue is being executed during freeze.

#### CWP[5:0] — Command Word Pointer Field

The command word pointer (CWP) denotes which CCW is executing at present or was last completed. CWP is a read-only field with a valid range of 0 to 63; write operations have no effect.

When a queue enters the paused state, CWP points to the CCW with the pause bit set. While in pause, the CWP value is maintained until a trigger event occurs on either queue. Usually, the CWP is updated a few clock cycles before the queue status field shows that the queue has become active. For example, a read of CWP may point to a CCW in queue 2, while the queue status field shows queue 1 paused and queue 2 trigger pending.

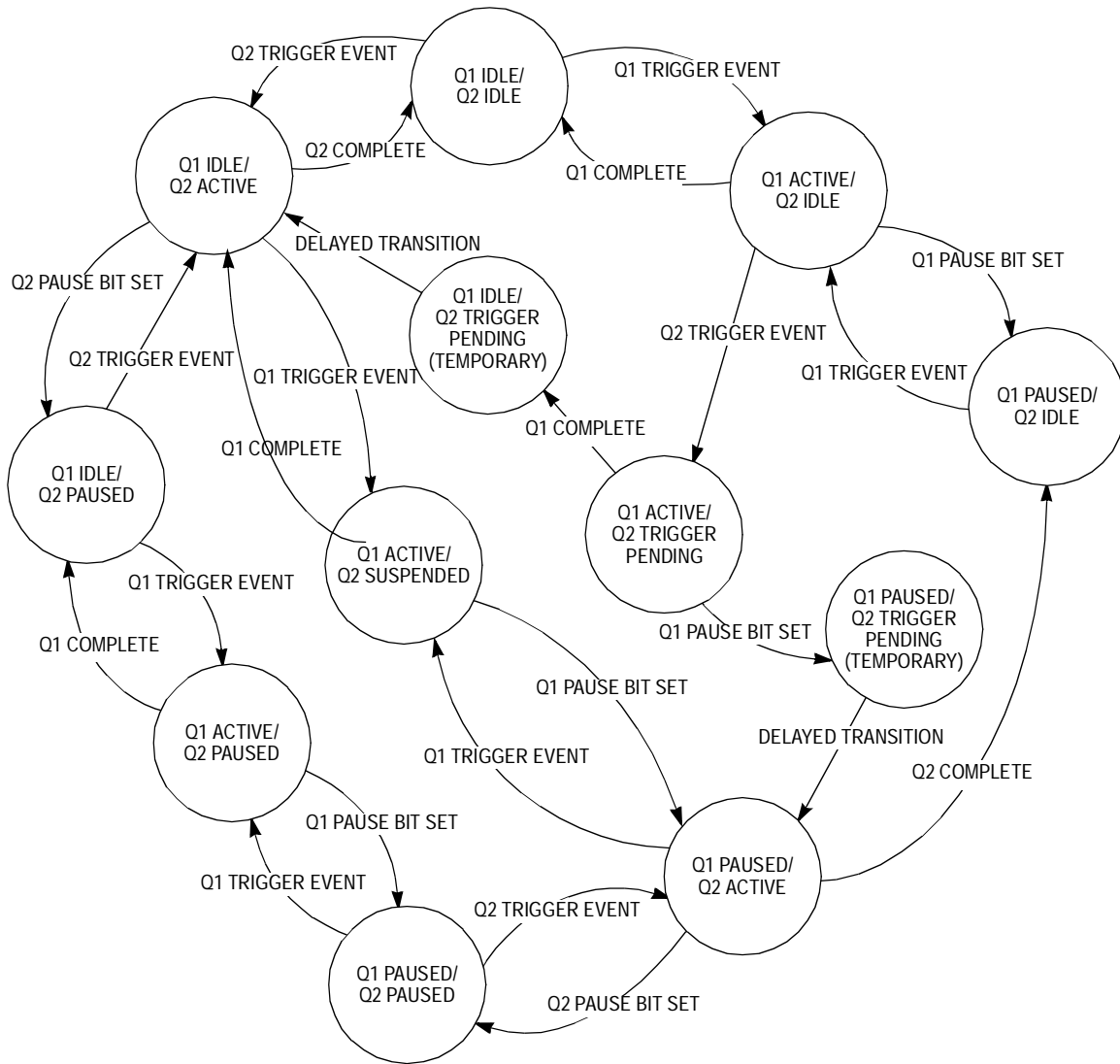

**Figure 19-12. Queue Status Transition**

When the QADC finishes a queue scan, the CWP points to the CCW where the end-of-queue condition was detected. Therefore, when the end-of-queue condition is a CCW with the EOQ code (channel 63), the CWP points to the CCW containing the EOQ.

When the last CCW in a queue is the last CCW table location (CCW63), and it does not contain the EOQ code, the end-of-queue is detected when the following CCW is read, so the CWP points to word CCW0.

**Queued Analog-to-Digital Converter (QADC)**

Finally, when queue 1 operation is terminated after a CCW is read that is pointed to by BQ2, the CWP points to the same CCW as BQ2. During stop mode, CWP is reset to 0 because the control registers and the analog logic are reset. When debug mode is entered, CWP is not changed; it points to the last executed CCW.

19.8.6.2 QADC Status Register 1 (QASR1)

Stop mode resets this register (\$3f3f).

Address: 0x00ca\_0012 and 0x00ca\_0013

	Bit 15	14	13	12	11	10	9	Bit 8
Read:	0	0	CWPQ15	CWPQ14	CWPQ13	CWPQ12	CWPQ11	CWPQ10
Write:								
Reset:	0	0	1	1	1	1	1	1
	Bit 7	6	5	4	3	2	1	Bit 0
Read:	0	0	CWPQ25	CWPQ24	CWPQ23	CWPQ22	CWPQ21	CWPQ20
Write:								
Reset:	0	0	1	1	1	1	1	1

= Writes have no effect and the access terminates without a transfer error exception.

**Figure 19-13. QADC Status Register 1 (QASR1)**

Read: Anytime

Write: Never

**CWPQ1[5:0] — Queue 1 Command Word Pointer Field**

CWPQ1[5:0] points to the last queue 1 CCW executed. This is a read-only field with a valid range of 0 to 63; writes have no effect. CWPQ1 always points to the last executed CCW in queue 1, regardless of which queue is active.

In contrast to CWP, CPWQ1 is updated when a conversion result is written. When the QADC finishes a conversion in queue 1, both the result register is written and CWPQ1 is updated.

Finally, when queue 1 operation is terminated after a CCW is read that is pointed to by BQ2, CWP points to BQ2 while CWPQ1 points to the last queue 1 CCW.

During stop mode, CWPQ1 is reset to 63, because the control registers and the analog logic are reset. When debug mode is entered, CWPQ1 is not changed; it points to the last executed CCW in queue 1.

#### CWPQ2[5:0] — Queue 2 Command Word Pointer Field

CWPQ2[5:0] points to the last queue 2 CCW executed. This is a read-only field with a valid range of 0 to 63; writes have no effect. CWPQ2 always points to the last executed CCW in queue 2, regardless which queue is active.

In contrast to CWP, CPWQ2 is updated when a conversion result is written. When the QADC finishes a conversion in queue 2, both the result register is written and CWPQ2 is updated.

During stop mode, CWPQ2 is reset to 63 because the control registers and the analog logic are reset. When debug mode is entered, CWPQ2 is not changed; it points to the last executed CCW in queue 2.

### 19.8.7 Conversion Command Word Table (CCW)

The conversion command word (CCW) table is 64 half-word (128 byte) long RAM with 10 bits of each entry implemented. The CCW table is written by the user and is not modified by the QADC. Each CCW requests the conversion of one analog channel to a digital result. The CCW specifies the analog channel number, the input sample time, and whether the queue is to pause after the current CCW.

**Queued Analog-to-Digital Converter (QADC)**

Address: 0x00ca\_0200 through 0x00ca\_027e

	Bit 15	14	13	12	11	10	9	Bit 8
Read:	0	0	0	0	0	0	P	BYP
Write:								
Reset:	0	0	0	0	0	0	U	U
	Bit 7	6	5	4	3	2	1	Bit 0
Read:	IST1	IST0	CHAN5	CHAN4	CHAN3	CHAN2	CHAN1	CHAN0
Write:								
Reset:	U	U	U	U	U	U	U	U

= Writes have no effect and the access terminates without a transfer error exception.

U = Unaffected

**Figure 19-14. Conversion Command Word Table (CCW)**

Read: Anytime except reads during stop mode are invalid

Write: Anytime except during stop mode

P — Pause Bit

The pause bit allows subqueues to be created within queue 1 and queue 2. The QADC performs the conversion specified by the CCW with the pause bit set and then the queue enters the pause state. Another trigger event causes execution to continue from the pause to the next CCW.

1 = Enter pause state after execution of current CCW.

0 = Do not enter pause state after execution of current CCW.

**NOTE:** *The P bit does not cause the queue to pause in the software. Initiated modes or externally gated modes.*

BYP — Sample Amplifier Bypass Bit

Setting BYP in a CCW enables the amplifier bypass mode for a conversion and subsequently changes the timing. The initial sample time is eliminated, reducing the potential conversion time by two QCLKs. However, due to internal RC effects, a minimum final sample time of four QCLKs must be allowed. When using this mode, the



external circuit should be of low source impedance. Loading effects of the external circuitry need to be considered because the benefits of the sample amplifier are not present.

1 = Amplifier bypass mode enabled

0 = Amplifier bypass mode disabled

**NOTE:** *BYP is maintained for software compatibility but has no functional benefit on this version of the QADC.*

#### IST[1:0] — Input Sample Time Field

The IST field specifies the length of the sample window. The input sample time can be varied, under software control, to accommodate various input channel source impedances. Longer sample times permit more accurate A/D conversions of signals with higher source impedances.

**Table 19-8** shows the four selectable input sample times.

**Table 19-8. Input Sample Times**

IST[1:0]	Input Sample Times
00	Input sample time = QCLK period × 2
01	Input sample time = QCLK period × 4
10	Input sample time = QCLK period × 8
11	Input sample time = QCLK period × 16

The programmable sample time can also be used to adjust queue execution time or sampling rate by increasing the time interval between conversions.

#### CHAN[5:0] — Channel Number Field

The CHAN field selects the input channel number. The CCW channel field is programmed with the channel number corresponding to the analog input pin to be sampled and converted. The analog input pin channel number assignments and the pin definitions vary depending on whether the QADC multiplexed or non-multiplexed mode is used by the application. As far as queue scanning operations are concerned, there is no distinction between an internally or externally multiplexed analog input.

**Queued Analog-to-Digital Converter (QADC)**

**Table 19-9** shows the channel number assignments for non-multiplexed mode. **Table 19-10** shows the channel number assignments for multiplexed mode.

Programming the channel field to channel 63 denotes the end of the queue. Channels 60 to 62 are special internal channels. When one of the special channels is selected, the sampling amplifier is not used. The value of  $V_{RL}$ ,  $V_{RH}$ , or  $(V_{RH}-V_{RL})/2$  is converted directly.

Programming any input sample time other than two has no benefit for the special internal channels except to lengthen the overall conversion time.

**Table 19-9. Non-Multiplexed Channel Assignments and Pin Designations**

Non-Multiplexed Input Pins				Channel Number <sup>(1)</sup> in CCW CHAN Field	
Port Pin Name	Analog Pin Name	Other Functions	Pin Type	Binary	Decimal
PQB0	AN0	—	Input	000000	0
PQB1	AN1	—	Input	000001	1
PQB2	AN2	—	Input	000010	2
PQB3	AN3	—	Input	000011	3
PQA0	AN52	—	Input/output	110100	52
PQA1	AN53	—	Input/output	110101	53
PQA3	AN55	ETRIG1	Input/output	110111	55
PQA4	AN56	ETRIG2	Input/output	111000	56
$V_{RL}$	Low reference	—	Input	111100	60
$V_{RH}$	High reference	—	Input	111101	61
—	—	$(V_{RH}-V_{RL})/2$	—	111110	62
—	—	End-of-queue code	—	111111	63

1. All channels not listed are reserved or unimplemented and return undefined results.

**Table 19-10. Multiplexed Channel Assignments  
 and Pin Designations**

Multiplexed Input Pins				Channel Number <sup>(1)</sup> in CCW CHAN Field	
Port Pin Name	Analog Pin Name	Other Functions	Pin Type	Binary	Decimal
PQB0	ANw	—	Input	000XX0	0, 2, 4, 6
PQB1	ANx	—	Input	000XX1	1, 3, 5, 7
PQB2	ANy	—	Input	010XX0	16, 18, 20, 22
PQB3	ANz	—	Input	010XX1	17, 19, 21, 23
PQA0	—	MA0	Output	110100	52
PQA1	—	MA1	Output	110101	53
PQA3	AN55	ETRIG1	Input/output	110111	55
PQA4	AN56	ETRIG2	Input/output	111000	56
V <sub>RL</sub>	Low reference	—	Input	111100	60
V <sub>RH</sub>	High reference	—	Input	111101	61
—	—	(V <sub>RH</sub> - V <sub>RL</sub> )/2	—	111110	62
—	—	End-of-queue code	—	111111	63

1. All channels not listed are reserved or unimplemented and return undefined results.

**Queued Analog-to-Digital Converter (QADC)**

**19.8.8 Result Registers**

The result word table is a 64 half-word (128 byte) long by 10-bit wide RAM. An entry is written by the QADC after completing an analog conversion specified by the corresponding CCW table entry.

*19.8.8.1 Right-Justified Unsigned Result Register (RJURR)*

Address: 0x00ca\_0280 through 0x00ca\_02fe

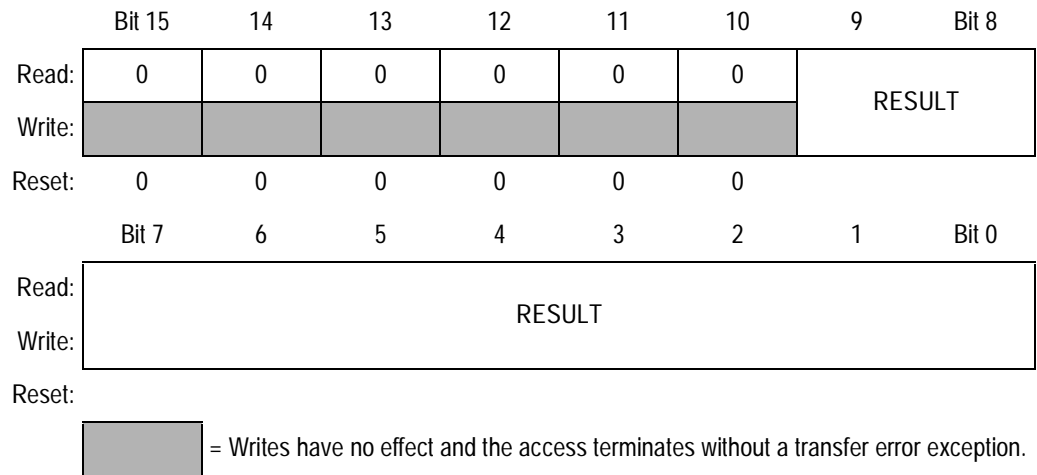

**Figure 19-15. Right-Justified Unsigned Result Register (RJURR)**

Read: Anytime except reads during stop mode are invalid

Write: Anytime except during stop mode

RESULT[9:0] — Result Field

The conversion result is unsigned, right-justified data.

19.8.8.2 Left-Justified Signed Result Register (LJSRR)

Address: 0x00ca\_0300 through 0x00ca\_037e

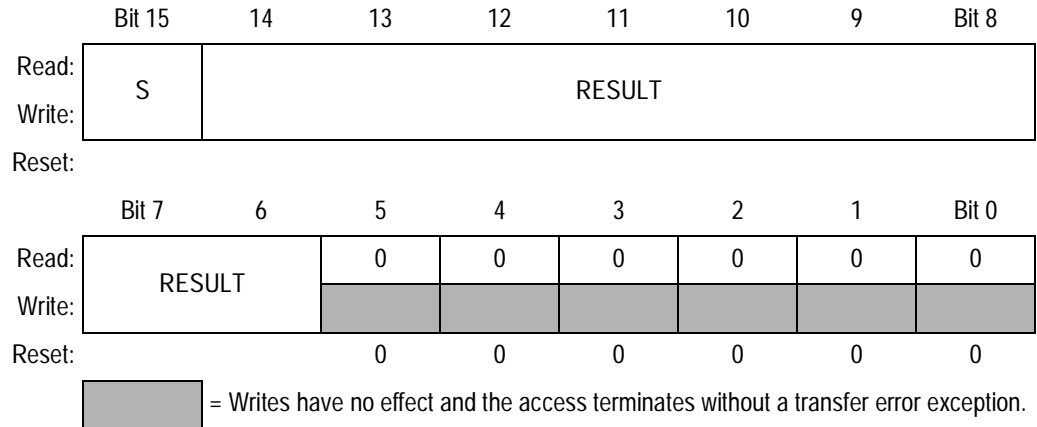

**Figure 19-16. Left-Justified Signed Result Register (LJSRR)**

**S — Sign Bit**

The left justified, signed format corresponds to a half-scale, offset binary, two's complement data format. Conversion values corresponding to 1/2 full scale, 0x0200, or higher are interpreted as positive values and have a sign bit of 0. An unsigned, right justified conversion of 0x0200 would be represented as 0x0000 in this signed register, where the sign = 0 and the result = 0. For an unsigned, right justified conversion of 0x3FF (full range or  $V_{RH}$ ), the signed equivalent in this register would be 0x7FC0, sign = 0 and result = 0x1FF. For an unsigned, right justified conversion of 0x0000 ( $V_{RL}$ ), the signed equivalent in this register would be 0x8000, sign = 1 and result = 0x000, a two's complement value representing -512.

**RESULT[14:6] — Result Field**

The conversion result is signed, left-justified data.

**Queued Analog-to-Digital Converter (QADC)**

19.8.8.3 Left-Justified Unsigned Result Register (LJURR)

Address: 0x00ca\_0380 through 0x00ca\_03fe

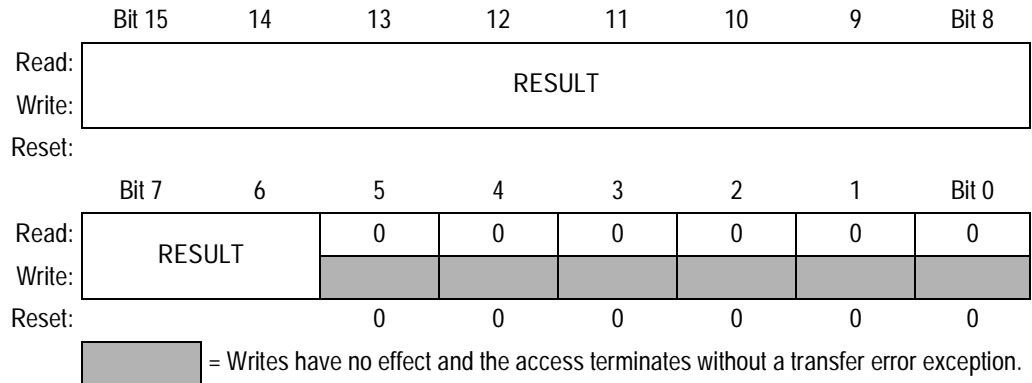

**Figure 19-17. Left-Justified Unsigned Result Register (LJURR)**

RESULT[15:6] — Result Field

The conversion result is unsigned, left-justified data.

**19.9 Functional Description**

This subsection provides a functional description of the QADC.

**19.9.1 Result Coherency**

The QADC supports byte and half-word reads and writes across a 16-bit data bus interface. All conversion results are stored in half-word registers, and the QADC does not allow more than one result register to be read at a time. For this reason, the QADC does not guarantee read coherency.

Specifically, this means that while the QADC is operating, the data in the result registers can change from one read to the next. Simply initiating a read of one result register will not prevent another from being updated with a new conversion result.

Thus, to read any given number of result registers coherently, the queue or queues capable of modifying these registers must be inactive. This can be guaranteed by system operating conditions (such as, known completion of a software-initiated queue single-scan or no possibility of an externally triggered/gated queue scan) or by simply disabling the queues (writing MQ1 and/or MQ2 to 0).

## 19.9.2 External Multiplexing

External multiplexer chips concentrate a number of analog signals onto a few QADC inputs. This is useful for applications that need to convert more analog signals than the QADC converter can normally support. External multiplexing also puts the multiplexed chip closer to the signal source. This minimizes the number of analog signals that need to be shielded due to the proximity of noisy high speed digital signals at the microcontroller chip.

For example, four 4-input multiplexer chips can be put at the connector where the analog signals first arrive on the printed circuit board. As a result, only four analog signals need to be shielded from noise as they approach the microcontroller chip, rather than having to protect 16 analog signals. However, external multiplexer chips may introduce additional noise and errors if not properly utilized. Therefore, it is necessary to maintain low “on” resistance (the impedance of an analog switch when active within a multiplexed chip) and insert a low pass filter (R/C) on the input side of the multiplexed chip.

### 19.9.2.1 External Multiplexing Operation

The QADC can use from one to four external multiplexer chips to expand the number of analog signals that may be converted. Up to 16 analog channels can be converted through external multiplexer selection. The externally multiplexed channels are automatically selected from the channel field of the CCW, the same as internally multiplexed channels. The QADC is configured for the externally multiplexed mode by setting the MUX bit in Control Register 0 (QACR0).

**Figure 19-18** shows the maximum configuration of four external multiplexer chips connected to the QADC. The external multiplexer chips select one of four analog inputs and connect it to one analog output, which becomes an input to the QADC. The QADC provides two multiplexed address signals — MA[1:0] — to select one of four inputs. These inputs are connected to all four external multiplexer chips. The analog output of the four multiplexer chips are each connected to separate QADC inputs (ANw, ANx, ANy, and ANz) as shown in **Figure 19-18**.

Queued Analog-to-Digital Converter (QADC)

Freescale Semiconductor, Inc.

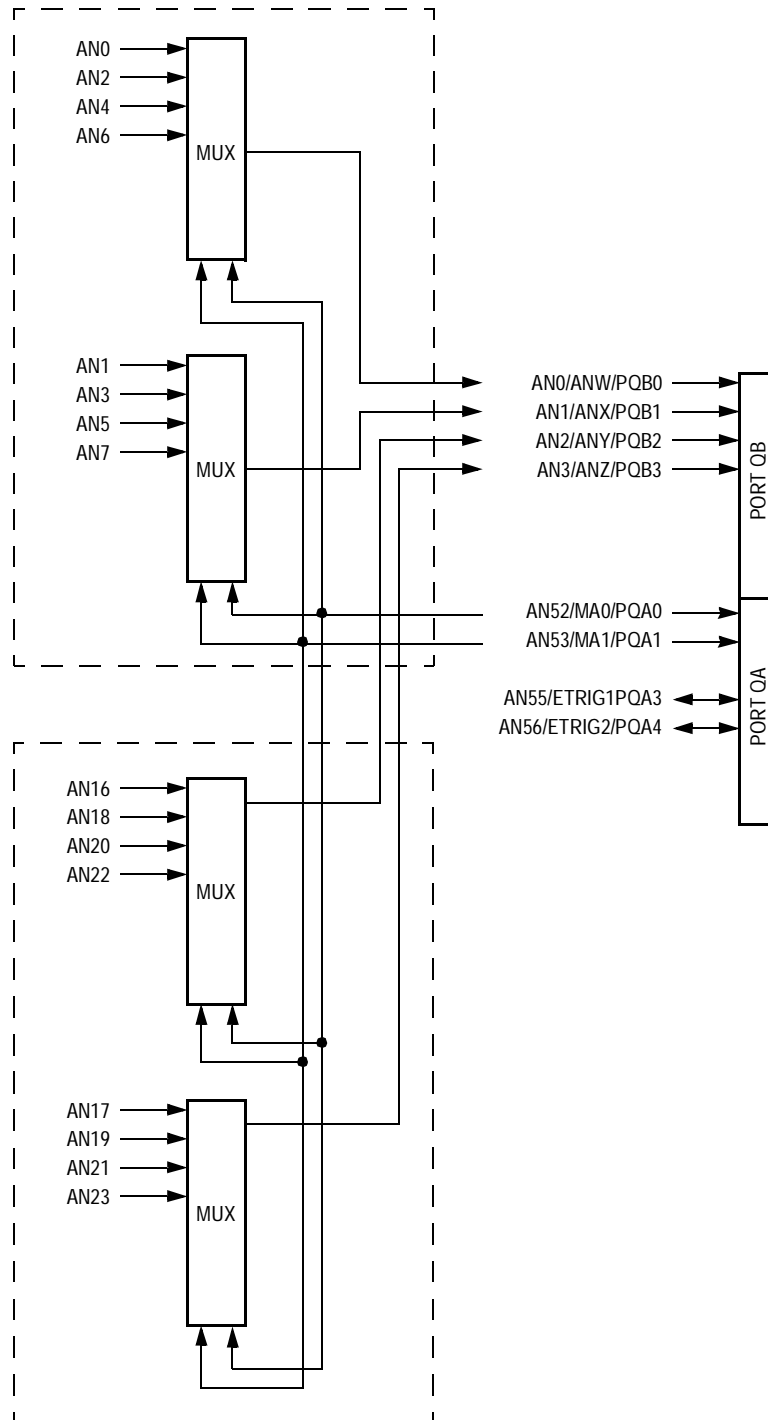

Figure 19-18. External Multiplexing Configuration



When externally multiplexed mode is selected, the QADC automatically drives the MA output signals from the channel number in each CCW. The QADC also converts the proper input channel (ANw, ANx, ANy, and ANz) by interpreting the CCW channel number. As a result, up to 16 externally multiplexed channels appear to the conversion queues as directly connected signals. User software simply puts the channel number of externally multiplexed channels into CCWs.

**Figure 19-18** shows that the two MA signals may also be analog input pins. When external multiplexing is selected, none of the MA pins can be used for analog or digital inputs. They become multiplexed address outputs and are unaffected by DDRQA[1:0].

### 19.9.2.2 Module Version Options

The number of available analog channels varies, depending on whether external multiplexing is used. A maximum of eight analog channels are supported by the internal multiplexing circuitry of the converter.

**Table 19-11** shows the total number of analog input channels supported with 0 to 4 external multiplexer chips.

**Table 19-11. Analog Input Channels**

Number of Analog Input Channels Available Directly Connected + External Multiplexed = Total Channels <sup>(1), (2)</sup>				
No External Mux	One External Mux	Two External Muxes	Three External Muxes	Four External Muxes
8	5 + 4 = 9	4 + 8 = 12	3 + 12 = 15	2 + 16 = 18

1. The external trigger inputs are not shared with two analog input pins.
2. When external multiplexing is used, two input channels are configured as multiplexed address outputs, and for each external multiplexer chip, one input channel is a multiplexed analog input.

**Queued Analog-to-Digital Converter (QADC)**

**19.9.3 Analog Subsystem**

This section describes the QADC analog subsystem, which includes the front-end analog multiplexer and analog-to-digital converter.

*19.9.3.1 Analog-to-Digital Converter Operation*

The analog subsystem consists of the path from the input pins to the A/D converter block. Signals from the queue control logic are fed to the multiplexer and state machine. The end-of-conversion (EOC) signal and the Successive Approximation Register (SAR) reflect the result of the conversion. **Figure 19-19** shows a block diagram of the QADC analog subsystem.

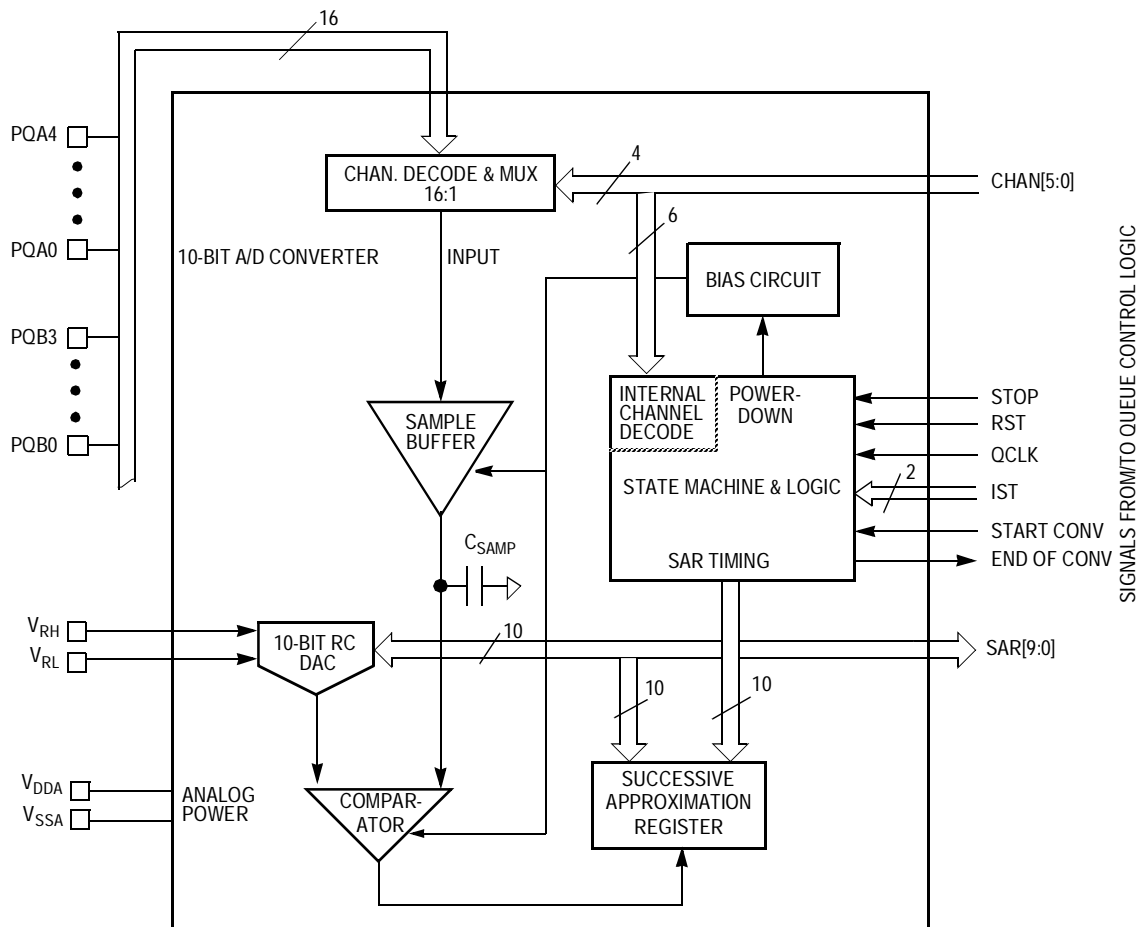

**Figure 19-19. QADC Analog Subsystem Block Diagram**

### 19.9.3.2 Conversion Cycle Times

Total conversion time is made up of initial sample time, final sample time, and resolution time. Initial sample time refers to the time during which the selected input channel is coupled through the sample buffer amplifier to the sample capacitor. The sample buffer is used to quickly reproduce its input signal on the sample capacitor and minimize charge sharing errors. During the final sampling period the amplifier is bypassed, and the multiplexer input charges the sample capacitor array directly for improved accuracy. During the resolution period, the voltage in the sample capacitor is converted to a digital value and stored in the SAR.

Initial sample time is fixed at two QCLK cycles. Final sample time can be 2, 4, 8, or 16 QCLK cycles, depending on the value of the IST field in the CCW. Resolution time is 10 QCLK cycles.

A conversion requires a minimum of 14 QCLK cycles (7  $\mu$ s with a 2.0-MHz QCLK). If the maximum final sample time period of 16 QCLKs is selected, the total conversion time is 28 QCLKs or 14  $\mu$ s (with a 2.0-MHz QCLK).

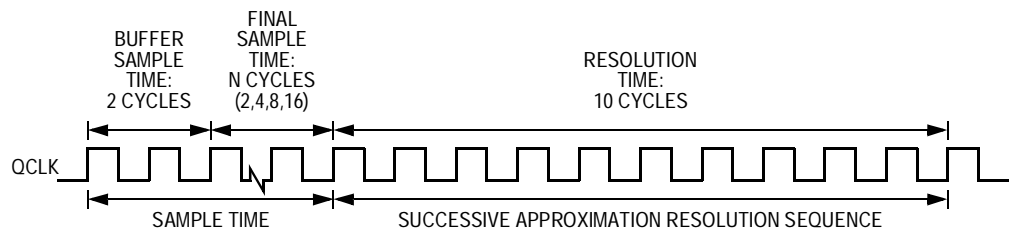
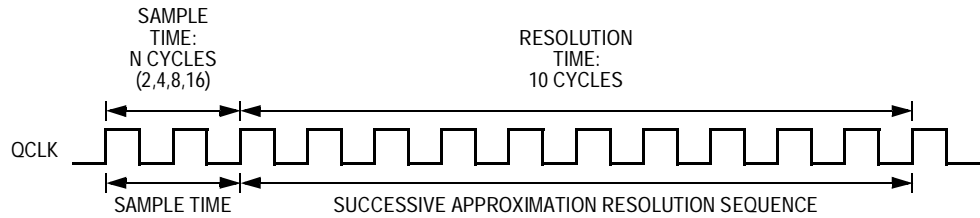

**Figure 19-20. Conversion Timing**

If the amplifier bypass mode is enabled for a conversion by setting the amplifier bypass (BYP) field in the CCW, the timing changes to that shown in [Figure 19-21](#). See [19.8.7 Conversion Command Word Table \(CCW\)](#) for more information on the BYP field. The initial sample time is eliminated, reducing the potential conversion time by two QCLKs. When using the bypass mode, the external circuit should be of low source impedance (typically less than 10 k $\Omega$ ). Also, the loading effects on the external circuitry of the QADC need to be considered, because the benefits of the sample amplifier are not present.

**Queued Analog-to-Digital Converter (QADC)**

**NOTE:** Because of internal RC time constants, use of a two QCLK sample time in bypass mode will cause serious errors when operating the QADC at high frequencies.



**Figure 19-21. Bypass Mode Conversion Timing**

19.9.3.3 Channel Decode and Multiplexer

The internal multiplexer selects one of the eight analog input pins for conversion. The selected input is connected to the sample buffer amplifier or to the sample capacitor. The multiplexer also includes positive and negative stress protection circuitry, which prevents deselected channels from affecting the selected channel when current is injected into the deselected channels.

19.9.3.4 Sample Buffer

The sample buffer is used to raise the effective input impedance of the A/D converter, so that external factors (higher bandwidth or higher impedance) are less critical to accuracy. The input voltage is buffered onto the sample capacitor to reduce crosstalk between channels.

19.9.3.5 Digital-to-Analog Converter (DAC) Array

The digital-to-analog converter (DAC) array consists of binary-weighted capacitors and a resistor-divider chain. The reference voltages,  $V_{RH}$  and  $V_{RL}$ , are used by the DAC to perform ratiometric conversions. The DAC also converts the following three internal channels:

- $V_{RH}$  — reference voltage high
- $V_{RL}$  — reference voltage low
- $(V_{RH}-V_{RL})/2$  — reference voltage

The DAC array provides a mechanism for the successive approximation A/D conversion.

Resolution begins with the most significant bit (MSB) and works down to the least significant bit (LSB). The switching sequence is controlled by the comparator and SAR logic. The sample capacitor samples and holds the voltage to be converted.

#### 19.9.3.6 *Comparator*

During the approximation process, the comparator senses whether the digitally selected arrangement of the DAC array produces a voltage level higher or lower than the sampled input. The comparator output feeds into the SAR which accumulates the A/D conversion result sequentially, beginning with the MSB.

#### 19.9.3.7 *Bias*

The bias circuit is controlled by the STOP signal to power-up and power-down all the analog circuits.

#### 19.9.3.8 *Successive Approximation Register*

The input of the SAR is connected to the comparator output. The SAR sequentially receives the conversion value one bit at a time, starting with the MSB. After accumulating the 10 bits of the conversion result, the SAR data is transferred to the appropriate result location, where it may be read by user software.

#### 19.9.3.9 *State Machine*

The state machine generates all timing to perform an A/D conversion. An internal start-conversion signal indicates to the A/D converter that the desired channel has been sent to the MUX.  $IST[1:0]$  denotes the desired sample time.  $BYP$  determines whether to bypass the sample amplifier. Once the end of conversion has been reached a signal is sent to the queue control logic indicating that a result is available for storage in the result RAM.

## 19.10 Digital Control

The digital control subsystem includes the control logic to sequence the conversion activity, the clock and periodic/interval timer, control and status registers, the conversion command word table RAM, and the result word table RAM.

The central element for control of QADC conversions is the 64-entry conversion command word (CCW) table. Each CCW specifies the conversion of one input channel. Depending on the application, one or two queues can be established in the CCW table. A queue is a scan sequence of one or more input channels. By using a pause mechanism, subqueues can be created in the two queues. Each queue can be operated using one of several different scan modes. The scan modes for queue 1 and queue 2 are programmed in control registers QACR1 and QACR2. Once a queue has been started by a trigger event (any of the ways to cause the QADC to begin executing the CCWs in a queue or subqueue), the QADC performs a sequence of conversions and places the results in the result word table.

### 19.10.1 Queue Priority Timing Examples

This subsection describes the QADC priority scheme when trigger events on two queues overlap or conflict.

#### 19.10.1.1 Queue Priority

Queue 1 has priority over queue 2 execution. These cases show the conditions under which queue 1 asserts its priority:

- When a queue is not active, a trigger event for queue 1 or queue 2 causes the corresponding queue execution to begin.
- When queue 1 is active and a trigger event occurs for queue 2, queue 2 cannot begin execution until queue 1 reaches completion or the paused state. The status register records the trigger event by reporting the queue 2 status as trigger pending. Additional trigger events for queue 2, which occur before execution can begin, are flagged as trigger overruns.

- When queue 2 is active and a trigger event occurs for queue 1, the current queue 2 conversion is aborted. The status register reports the queue 2 status as suspended. Any trigger events occurring for queue 2 while it is suspended are flagged as trigger overruns. Once queue 1 reaches the completion or the paused state, queue 2 begins executing again. The programming of the RESUME bit in QACR2 determines which CCW is executed in queue 2.
- When simultaneous trigger events occur for queue 1 and queue 2, queue 1 begins execution and the queue 2 status is changed to trigger pending.
- When subqueues are paused

The pause feature can be used to divide queue 1 and/or queue 2 into multiple subqueues. A subqueue is defined by setting the pause bit in the last CCW of the subqueue.

**Figure 19-22** shows the CCW format and an example of using pause to create subqueues. Queue 1 is shown with four CCWs in each subqueue and queue 2 has two CCWs in each subqueue.

The operating mode selected for queue 1 determines what type of trigger event causes the execution of each of the subqueues within queue 1. Similarly, the operating mode for queue 2 determines the type of trigger event required to execute each of the subqueues within queue 2.

For example, when the external trigger rising edge continuous-scan mode is selected for queue 1, and there are six subqueues within queue 1, a separate rising edge is required on the external trigger pin after every pause to begin the execution of each subqueue (refer to **Figure 19-22**).

The choice of single-scan or continuous-scan applies to the full queue, and is not applied to each subqueue. Once a subqueue is initiated, each CCW is executed sequentially until the last CCW in the subqueue is executed and the pause state is entered. Execution can only continue with the next CCW, which is the beginning of the next subqueue. A subqueue cannot be executed a second time before the overall queue execution has been completed.

Queued Analog-to-Digital Converter (QADC)

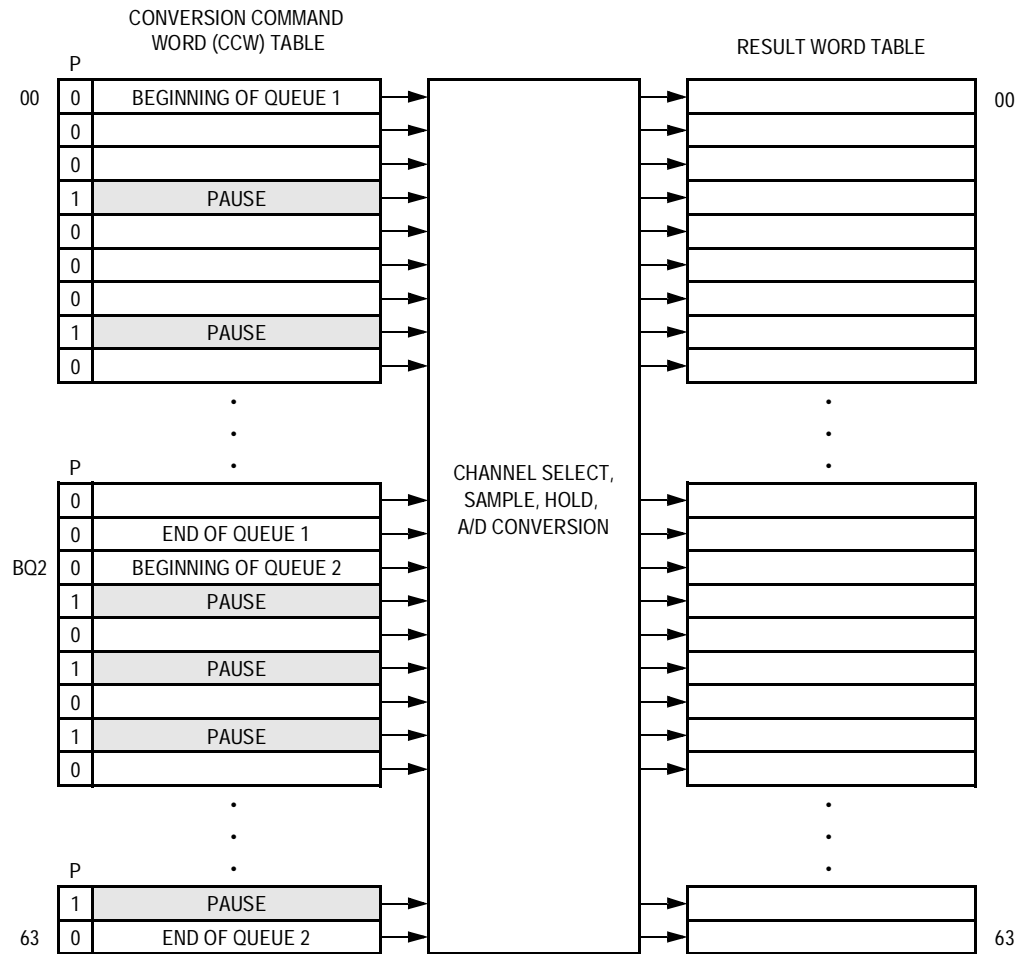

Figure 19-22. QADC Queue Operation with Pause

Trigger events which occur during the execution of a subqueue are ignored, except that the trigger overrun flag is set. When a continuous-scan mode is selected, a trigger event occurring after the completion of the last subqueue (after the queue completion flag is set), causes the execution to continue with the first subqueue, starting with the first CCW in the queue.

When the QADC encounters a CCW with the pause bit set, the queue enters the paused state after completing the conversion specified in the CCW with the pause bit. The pause flag is set and a pause interrupt may optionally be requested. The status of the queue is shown to be paused, indicating completion of a subqueue. The QADC then waits for another trigger event to again begin execution of the next subqueue.



## 19.10.1.2 Queue Priority Schemes

Because there are two conversion command queues and only one A/D converter, a priority scheme determines which conversion occurs. Each queue has a variety of trigger events that are intended to initiate conversions, and they can occur asynchronously in relation to each other and other conversions in progress. For example, a queue can be idle awaiting a trigger event; a trigger event can have occurred, but the first conversion has not started; a conversion can be in progress; a pause condition can exist awaiting another trigger event to continue the queue; and so on.

The following paragraphs and figures outline the prioritizing criteria used to determine which conversion occurs in each overlap situation.

**NOTE:** Each situation in [Figure 19-23](#) through [Figure 19-33](#) is labeled S1 through S19. In each diagram, time is shown increasing from left to right. The execution of queue 1 and queue 2 (Q1 and Q2) is shown as a string of rectangles representing the execution time of each CCW in the queue. In most of the situations, there are four CCWs (labeled C1 to C4) in both queue 1 and queue 2. In some of the situations, CCW C2 is presumed to have the pause bit set, to show the similarities of pause and end-of-queue as terminations of queue execution.

Trigger events are described in [Table 19-12](#).

**Table 19-12. Trigger Events**

Trigger	Events
T1	Events that trigger queue 1 execution (external trigger, software-initiated single-scan enable bit, or completion of the previous continuous loop)
T2	Events that trigger queue 2 execution (external trigger, software-initiated single-scan enable bit, timer period/interval expired, or completion of the previous continuous loop)

When a trigger event causes a CCW execution in progress to be aborted, the aborted conversion is shown as a ragged end of a shortened CCW rectangle.

The situation diagrams also show when key status bits are set. **Table 19-13** describes the status bits.

**Table 19-13. Status Bits**

Bit	Function
CF flag	Set when the end of the queue is reached
PF flag	Set when a queue completes execution up through a pause bit
Trigger overrun error (TOR)	Set when a new trigger event occurs before the queue is finished servicing the previous trigger event

Below the queue execution flows are three sets of blocks that show the status information that is made available to the user. The first two rows of status blocks show the condition of each queue as:

- Idle
- Active
- Pause
- Suspended (queue 2 only)
- Trigger pending

The third row of status blocks shows the 4-bit QS status register field that encodes the condition of the two queues. Two transition status cases, QS = 0011 and QS = 0111, are not shown because they exist only very briefly between stable status conditions.

The first three examples in **Figure 19-23** through **Figure 19-25** (S1, S2, and S3) show what happens when a new trigger event is recognized before the queue has completed servicing the previous trigger event on the same queue.

In situation S1 (**Figure 19-23**), one trigger event is being recognized on each queue while that queue is still working on the previously recognized trigger event. The trigger overrun error status bit is set, and the premature trigger event is otherwise ignored. A trigger event that occurs before the servicing of the previous trigger event is through does not disturb the queue execution in progress.

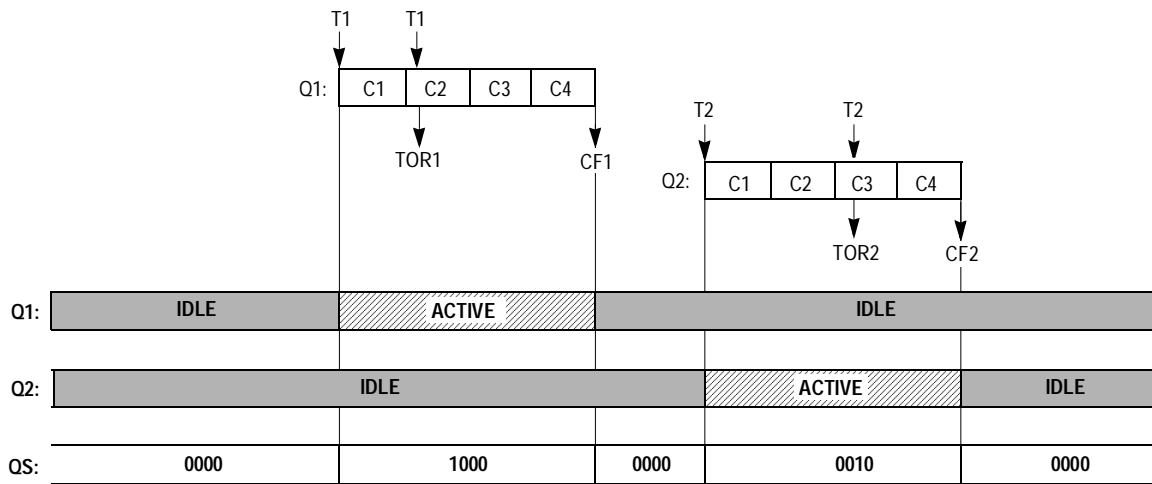

Figure 19-23. CCW Priority Situation 1

In situation S2 (Figure 19-24), more than one trigger event is recognized before servicing of a previous trigger event is complete. The trigger overrun bit is again set, but the additional trigger events are otherwise ignored. After the queue is complete, the first newly detected trigger event causes queue execution to begin again. When the trigger event rate is high, a new trigger event can be seen very soon after completion of the previous queue, leaving little time to retrieve the previous results. Also, when trigger events are occurring at a high rate for queue 1, the lower priority queue 2 channels may not get serviced at all.

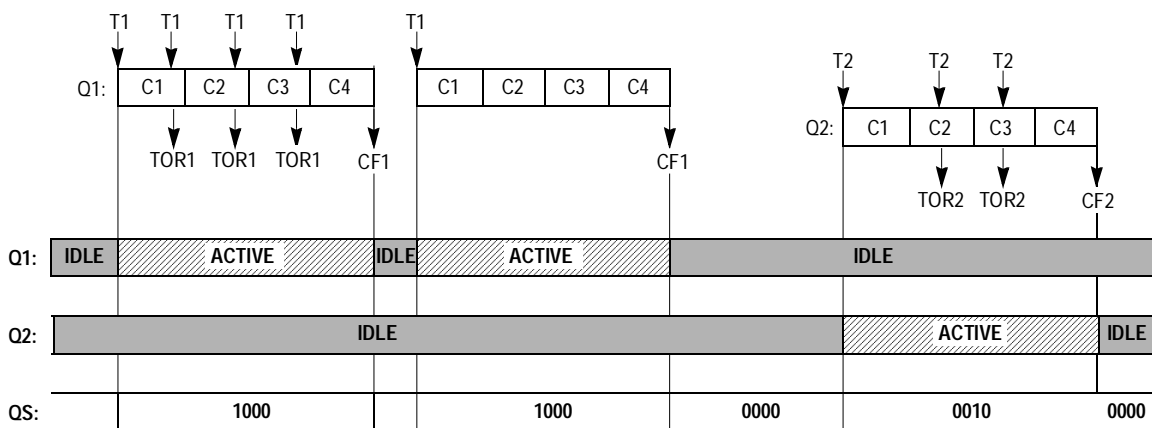
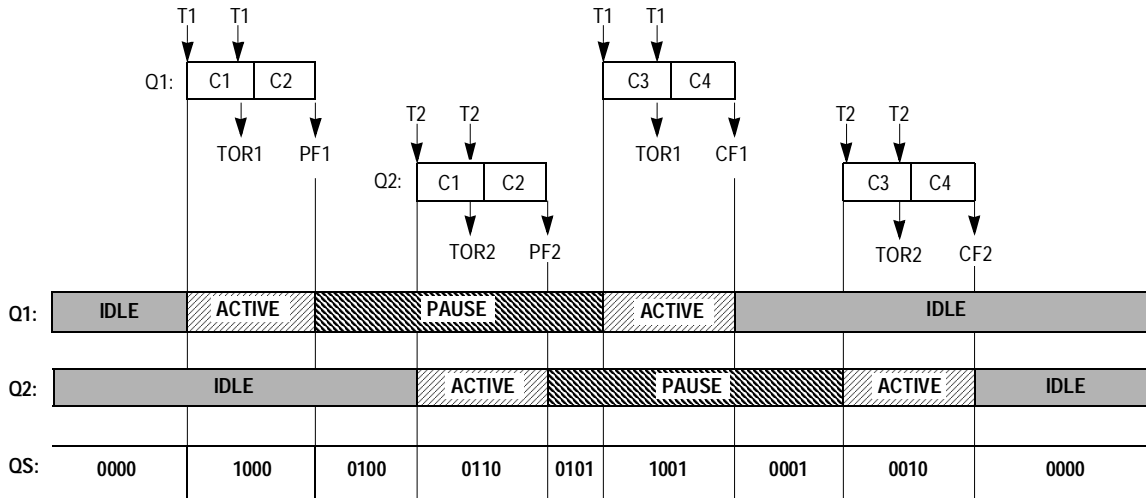

Figure 19-24. CCW Priority Situation 2

**Queued Analog-to-Digital Converter (QADC)**

Situation S3 (Figure 19-25) shows that when the pause feature is used, the trigger overrun error status bit is set the same way and that queue execution continues unchanged.



**Figure 19-25. CCW Priority Situation 3**

The next two situations consider trigger events that occur for the lower priority queue 2, while queue 1 is actively being serviced.

Situation S4 (Figure 19-26) shows that a queue 2 trigger event is recognized while queue 1 is active is saved, and as soon as queue 1 is finished, queue 2 servicing begins.

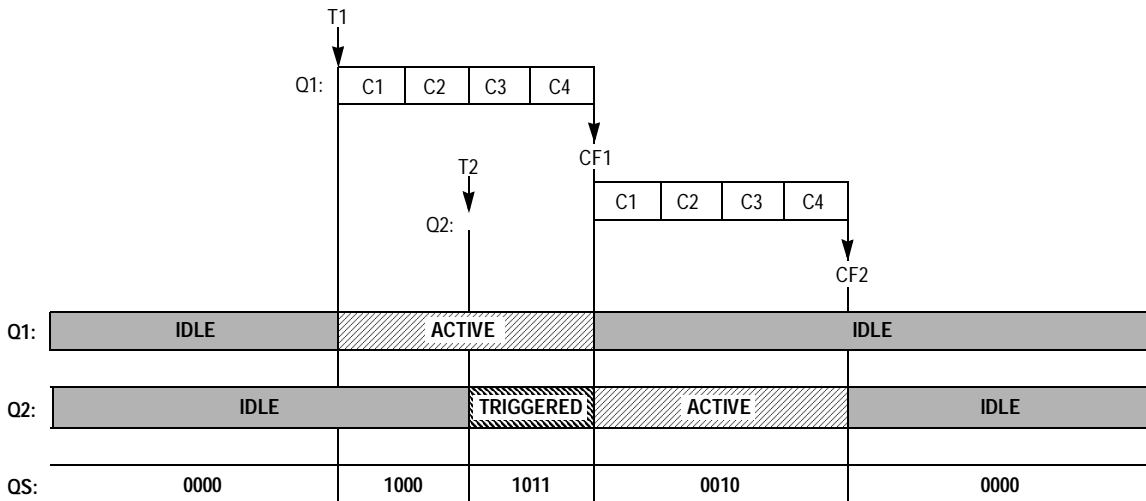

**Figure 19-26. CCW Priority Situation 4**

Situation S5 (Figure 19-27) shows that when multiple queue 2 trigger events are detected while queue 1 is busy, the trigger overrun error bit is set, but queue 1 execution is not disturbed. Situation S5 also shows that the effect of queue 2 trigger events during queue 1 execution is the same when the pause feature is used for either queue.

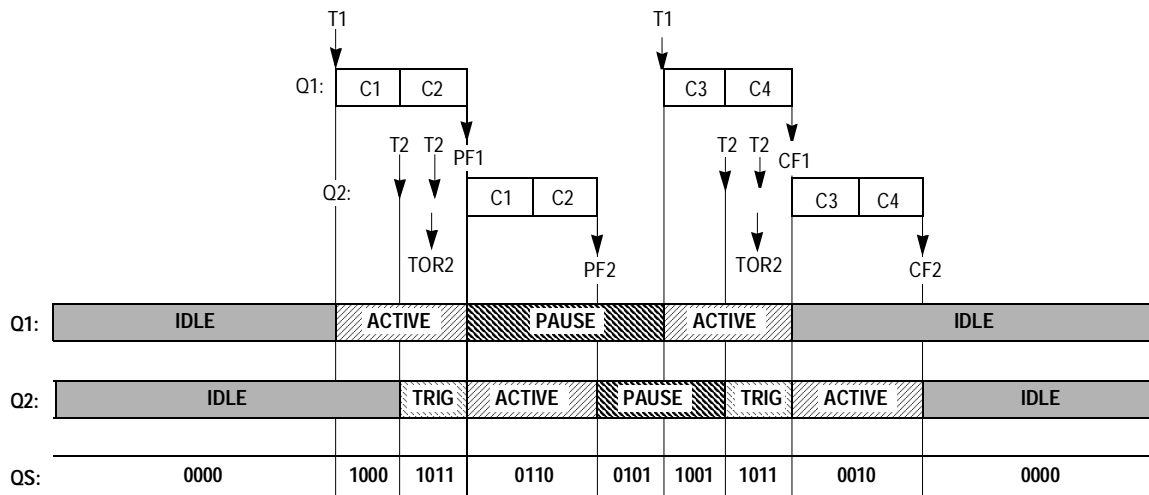

**Figure 19-27. CCW Priority Situation 5**

The remaining situations, S6 through S11, show the impact of a queue 1 trigger event occurring during queue 2 execution. Because queue 1 has higher priority, the conversion taking place in queue 2 is aborted so that there is no variable latency time in responding to queue 1 trigger events.

In situation 6 (Figure 19-28), the conversion initiated by the second CCW in queue 2 is aborted just before the conversion is complete, so that queue 1 execution can begin. Queue 2 is considered suspended. After queue 1 is finished, queue 2 starts over with the first CCW, when the RESUME control bit is set to 0. Situation S7 (Figure 19-29) shows that when pause operation is not used with queue 2, queue 2 suspension works the same way.

Queued Analog-to-Digital Converter (QADC)

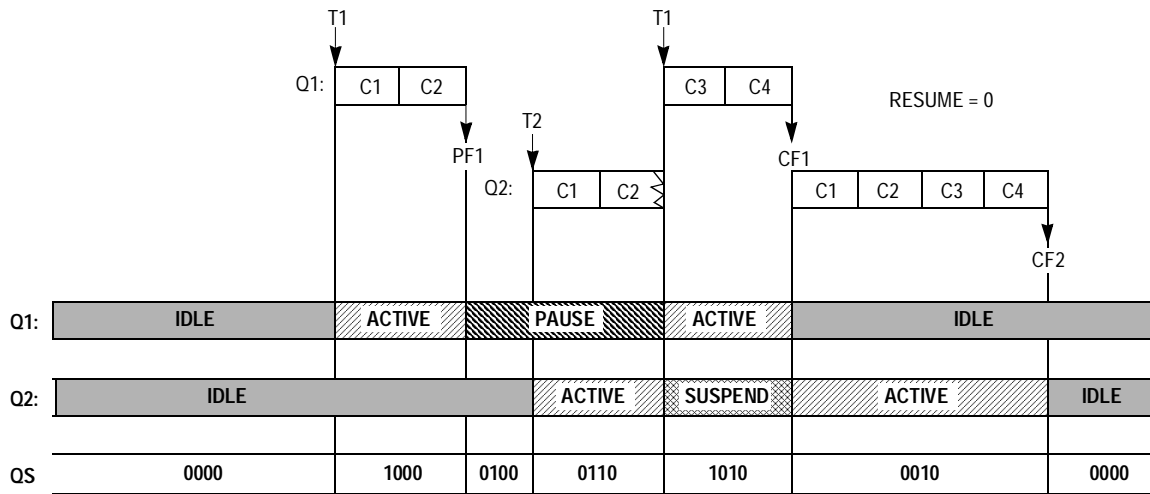

Figure 19-28. CCW Priority Situation 6

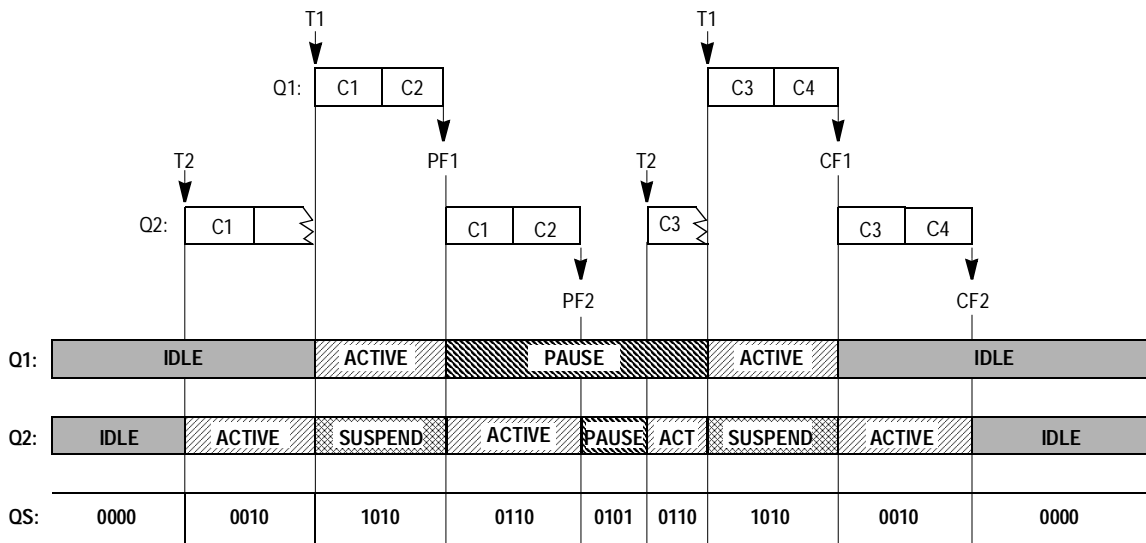

Figure 19-29. CCW Priority Situation 7

Situations S8 and S9 (Figure 19-30 and Figure 19-31) repeat the same two situations with the RESUME bit set to a 1. When the RESUME bit is set, following suspension, queue 2 resumes execution with the aborted CCW, not the first CCW, in the queue.

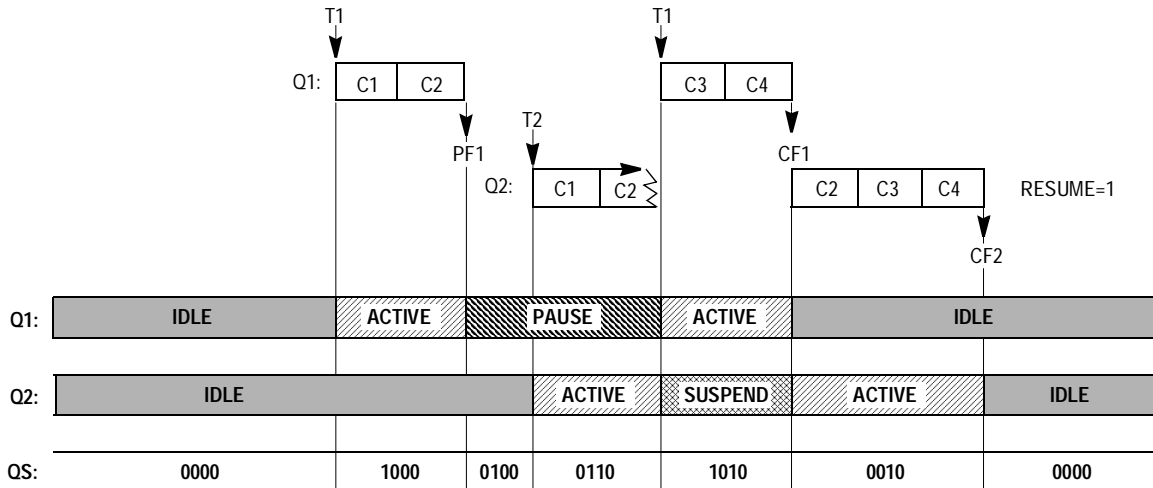

Figure 19-30. CCW Priority Situation 8

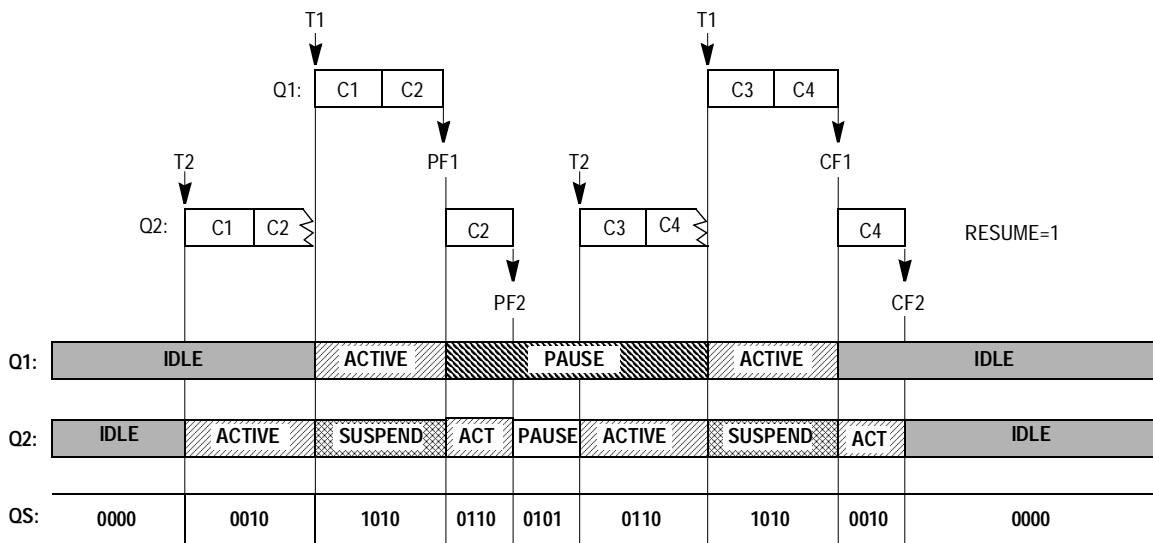

Figure 19-31. CCW Priority Situation 9

Queued Analog-to-Digital Converter (QADC)

Situations S10 and S11 (Figure 19-32 and Figure 19-33) show that when an additional trigger event is detected for queue 2 while the queue is suspended, the trigger overrun error bit is set, the same as if queue 2 were being executed when a new trigger event occurs. Trigger overrun on queue 2 thus allows the user to know that queue 1 is taking up so much QADC time that queue 2 trigger events are being lost.

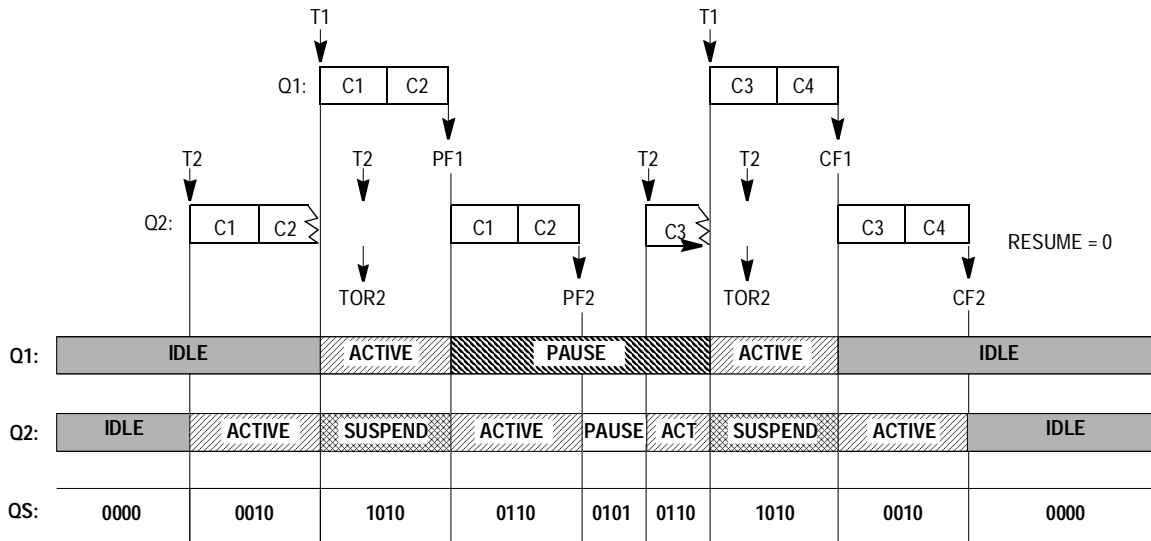

Figure 19-32. CCW Priority Situation 10

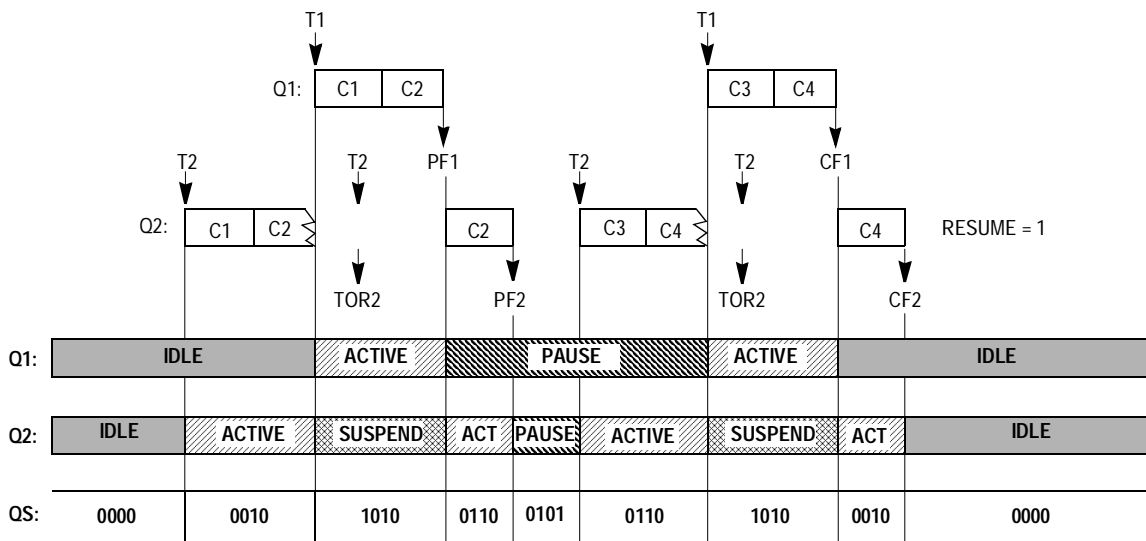

Figure 19-33. CCW Priority Situation 11



The previous situations cover normal overlap conditions that arise with asynchronous trigger events on the two queues. An additional conflict to consider is that the freeze condition can arise while the QADC is actively executing CCWs. The conventional use for the debug mode is for software/hardware debugging. When the CPU enters background debug mode, peripheral modules can cease operation. When freeze is detected, the QADC completes the conversion in progress, unlike the abort that occurs when queue 1 suspends queue 2. After the freeze condition is removed, the QADC continues queue execution with the next CCW in sequence.

Trigger events that occur during freeze are not captured. When a trigger event is pending for queue 2 before freeze begins, that trigger event is remembered when the freeze is passed. Similarly, when freeze occurs while queue 2 is suspended, after freeze, queue 2 resumes execution as soon as queue 1 is finished.

Situations 12 through 19 (Figure 19-34 to Figure 19-41) show examples of all of the freeze situations.

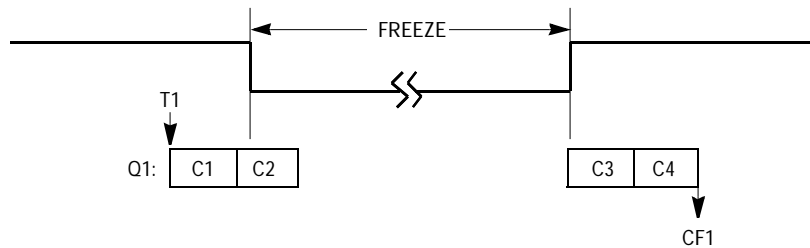

**Figure 19-34. CCW Freeze Situation 12**

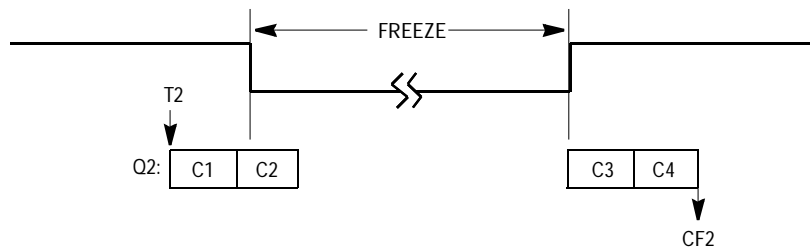

**Figure 19-35. CCW Freeze Situation 13**

Queued Analog-to-Digital Converter (QADC)

Freescale Semiconductor, Inc.

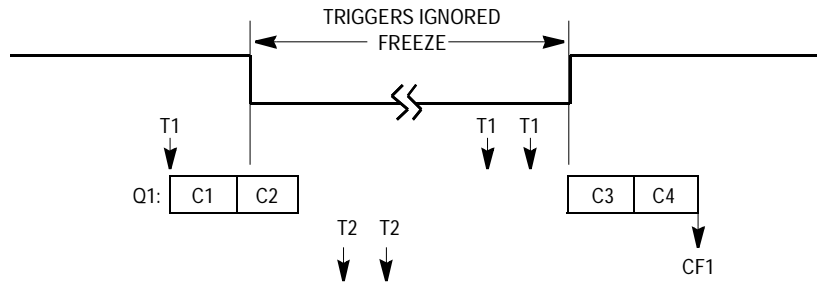

Figure 19-36. CCW Freeze Situation 14

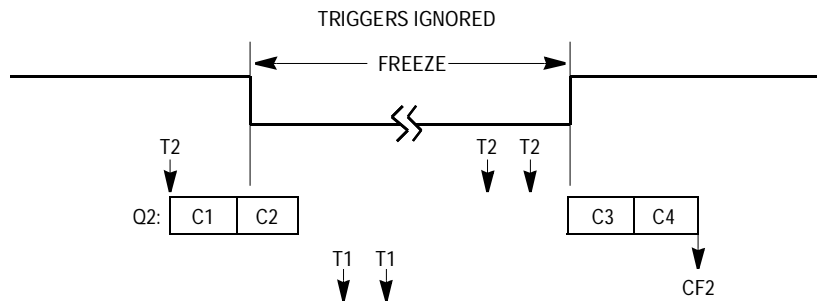

Figure 19-37. CCW Freeze Situation 15

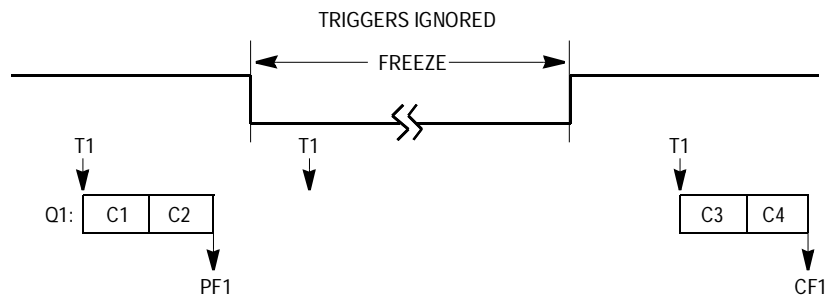
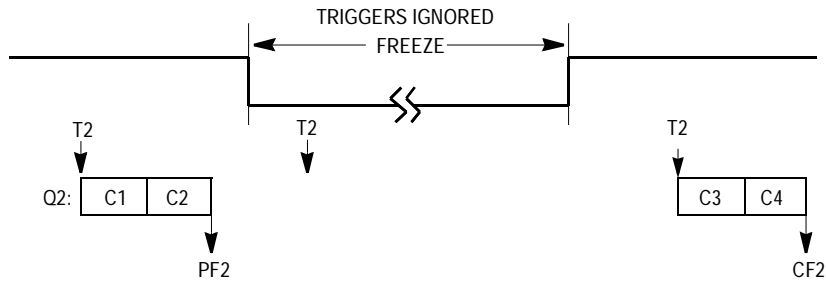
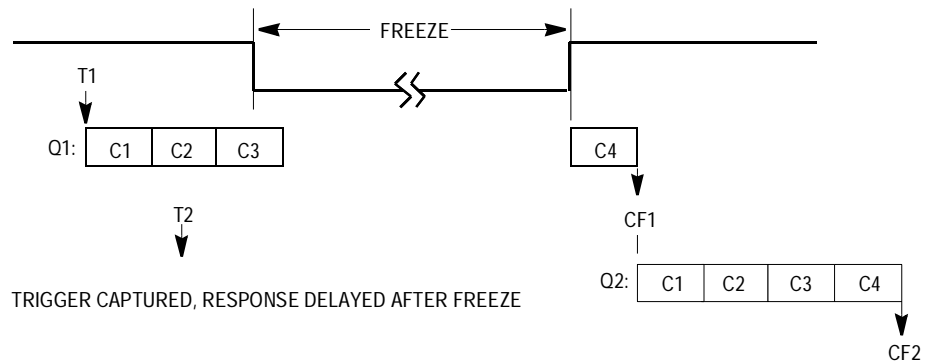

Figure 19-38. CCW Freeze Situation 16



**Figure 19-39. CCW Freeze Situation 17**



**Figure 19-40. CCW Freeze Situation 18**

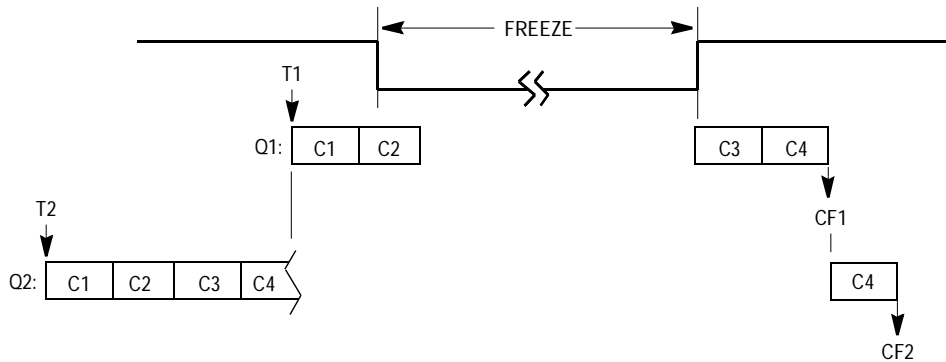

**Figure 19-41. CCW Freeze Situation 19**

### 19.10.2 Boundary Conditions

The queue operation boundary conditions are:

- The first CCW in a queue specifies channel 63, the end-of-queue (EOQ) code. The queue becomes active and the first CCW is read. The end-of-queue is recognized, the completion flag is set, and the queue becomes idle. A conversion is not performed.
- BQ2 (beginning of queue 2) is set at the end of the CCW table (63) and a trigger event occurs on queue 2. The end-of-queue condition is recognized, a conversion is performed, the completion flag is set, and the queue becomes idle.
- BQ2 is set to CCW0 and a trigger event occurs on queue 1. After reading CCW0, the end-of-queue condition is recognized, the completion flag is set, and the queue becomes idle. A conversion is not performed.
- BQ2 (beginning of queue 2) is set beyond the end of the CCW table (64–127) and a trigger event occurs on queue 2. The end-of-queue condition is recognized immediately, the completion flag is set, and the queue becomes idle. A conversion is not performed.

**NOTE:** *Multiple end-of-queue conditions may be recognized simultaneously, although there is no change in QADC behavior. For example, if BQ2 is set to CCW0, CCW0 contains the EOQ code, and a trigger event occurs on queue 1, the QADC reads CCW0 and detects both end-of-queue conditions. The completion flag is set and queue 1 becomes idle.*

Boundary conditions also exist for combinations of pause and end-of-queue. One case is when a pause bit is in one CCW and an end-of-queue condition is in the next CCW. The conversion specified by the CCW with the pause bit set completes normally. The pause flag is set. However, because the end-of-queue condition is recognized, the completion flag is also set and the queue status becomes idle, not paused. Examples of this situation include:

- The pause bit is set in CCW5 and the channel 63 (EOQ) code is in CCW6.
- The pause is in CCW63.
- During queue 1 operation, the pause bit is set in CCW20 and BQ2 points to CCW21.

Another pause and end-of-queue boundary condition occurs when the pause and an end-of-queue condition occur in the same CCW. Both the pause and end-of-queue conditions are recognized simultaneously. The end-of-queue condition has precedence so a conversion is not performed for the CCW and the pause flag is not set. The QADC sets the completion flag and the queue status becomes idle. Examples of this situation are:

- The pause bit is set in CCW10 and EOQ is programmed into CCW10.
- During queue 1 operation, the pause bit set in CCW32, which is also BQ2.

### 19.10.3 Scan Modes

The QADC queuing mechanism allows application software to utilize different requirements for automatically scanning input channels.

In single-scan mode, a single pass through a sequence of conversions defined by a queue is performed. In continuous-scan mode, multiple passes through a sequence of conversions defined by a queue are executed.

The possible modes are:

- Disabled mode and reserved mode
- Software-initiated single-scan mode
- Externally triggered single-scan mode
- Externally gated single-scan mode
- Interval timer single-scan mode
- Software-initiated continuous-scan mode
- Externally triggered continuous-scan mode
- Externally gated continuous-scan mode
- Periodic timer continuous-scan mode

The following paragraphs describe single-scan and continuous-scan operations.

#### 19.10.4 Disabled Mode

When disabled mode is selected, the queue is not active. Trigger events cannot initiate queue execution. When both queue 1 and queue 2 are disabled, there is no possibility of encountering wait states when accessing CCW table and result RAM. When both queues are disabled, it is safe to change the QCLK prescaler values.

#### 19.10.5 Reserved Mode

Reserved mode is available for future mode definitions. When reserved mode is selected, the queue is not active. The behavior is the same as disabled mode.

#### 19.10.6 Single-Scan Modes

A single-scan queue operating mode is used to execute a single pass through a sequence of conversions defined by a queue. By programming the MQ1 field in QACR1 or the MQ2 field in QACR2, these modes can be selected:

- Software-initiated single-scan mode
- Externally triggered single-scan mode
- Externally gated single-scan mode
- Interval timer single-scan mode

**NOTE:** *Queue 2 cannot be programmed for externally gated single-scan mode.*

In all single-scan queue operating modes, queue execution is enabled by writing the single-scan enable bit to a 1 in the queue's control register. The single-scan enable bits, SSE1 and SSE2, are provided for queue 1 and queue 2, respectively.

Until a queue's single-scan enable bit is set, any trigger events for that queue are ignored. The single-scan enable bit may be set to a 1 during the same write cycle that selects the single-scan queue operating mode. The single-scan enable bit can be written only to 1, but will always read 0. Once set, writing the single-scan enable bit to 0 has no effect.

Only the QADC can clear the single-scan enable bit. The completion flag, completion interrupt, or queue status is used to determine when the queue has completed.

After the single-scan enable bit is set, a trigger event causes the QADC to begin execution with the first CCW in the queue. The single-scan enable bit remains set until the queue is completed. After the queue reaches completion, the QADC resets the single-scan enable bit to 0. Writing the single-scan enable bit to a 1 or a 0 before the queue scan is complete has no effect; however, if the queue operating mode is changed, the new queue operating mode and the value of the single-scan enable bit are recognized immediately. The conversion in progress is aborted, and the new queue operating mode takes effect.

In software-initiated single-scan mode, writing a 1 to the single-scan enable bit causes the QADC to generate a trigger event internally, and queue execution begins immediately. In the other single-scan queue operating modes, once the single-scan enable bit is written, the selected trigger event must occur before the queue can start. The single-scan enable bit allows the entire queue to be scanned once. A trigger overrun is captured if a trigger event occurs during queue execution in an edge-sensitive external trigger mode or a periodic/interval timer mode.

In the interval timer single-scan mode, the next expiration of the timer is the trigger event for the queue. After queue execution is complete, the queue status is shown as idle. The queue can be restarted by setting the single-scan enable bit to 1. Queue execution begins with the first CCW in the queue.

#### 19.10.6.1 Software-Initiated Single-Scan Mode

Software can initiate the execution of a scan sequence for queue 1 or 2 by selecting software-initiated single-scan mode and writing the single-scan enable bit in QACR1 or QACR2. A trigger event is generated internally and the QADC immediately begins execution of the first CCW in the queue. If a pause occurs, another trigger event is generated internally, and then execution continues without pausing.

The QADC automatically performs the conversions in the queue until an end-of-queue condition is encountered. The queue remains idle until the

**Queued Analog-to-Digital Converter (QADC)**

single-scan enable bit is again set. While the time to internally generate and act on a trigger event is very short, the queue status field can be read as momentarily indicating that the queue is paused. The trigger overrun flag is never set while in software-initiated single-scan mode.

The software-initiated single-scan mode is useful when:

- Complete control of queue execution is required
- There is a need to easily alternate between several queue sequences

#### 19.10.6.2 Externally Triggered Single-Scan Mode

The externally triggered single-scan mode is available on both queue 1 and queue 2. Both rising and falling edge triggered modes are available. A scan must be enabled by setting the single-scan enable bit for the queue.

The first external trigger edge causes the queue to be executed one time. Each CCW is read and the indicated conversions are performed until an end-of-queue condition is encountered. After the queue is completed, the QADC clears the single-scan enable bit. The single-scan enable bit can be written again to allow another scan of the queue to be initiated by the next external trigger edge.

The externally triggered single-scan mode is useful when the input trigger rate can exceed the queue execution rate. Analog samples can be taken in sync with an external event, even though application software does not require data taken from every edge. Externally triggered single-scan mode can be enabled to get one set of data and, at a later time, be enabled again for the next set of samples.

When a pause bit is encountered during externally triggered single-scan mode, another trigger event is required for queue execution to continue. Software involvement is not required for queue execution to continue from the paused state.



### 19.10.6.3 Externally Gated Single-Scan Mode

The QADC provides external gating for queue 1 only. When externally gated single-scan mode is selected, the input level on the associated external trigger pin enables and disables queue execution. The polarity of the external gate signal is fixed so that only a high level opens the gate and a low level closes the gate. Once the gate is open, each CCW is read and the indicated conversions are performed until the gate is closed. Queue scan must be enabled by setting the single-scan enable bit for queue 1. If a pause is encountered, the pause flag does not set, and execution continues without pausing.

While the gate is open, queue 1 executes one time. Each CCW is read and the indicated conversions are performed until an end-of-queue condition is encountered. When queue 1 completes, the QADC sets the completion flag (CF1) and clears the single-scan enable bit. Set the single-scan enable bit again to allow another scan of queue 1 to be initiated during the next open gate.

If the gate closes before queue 1 completes execution, the current CCW completes, execution of queue 1 stops, the single-scan enable bit is cleared, and the PF1 bit is set. The CWPQ1 field can be read to determine the last valid conversion in the queue. The single-scan enable bit must be set again and the PF1 bit should be cleared before another scan of queue 1 is initiated during the next open gate. The start of queue 1 is always the first CCW in the CCW table.

Because the gate level is only sampled after each conversion during queue execution, closing the gate for a period less than a conversion time interval does not guarantee the closure will be captured.

### 19.10.6.4 Interval Timer Single-Scan Mode

Both queues can use the periodic/interval timer in a single-scan queue operating mode. The timer interval can range from  $2^7$  to  $2^{17}$  QCLK cycles in binary multiples. When the interval timer single-scan mode is selected and the single-scan enable bit is set in QACR1 or QACR2, the timer begins counting. When the time interval elapses, an internal trigger event is generated to start the queue and the QADC begins execution with the first CCW.

## Queued Analog-to-Digital Converter (QADC)

The QADC automatically performs the conversions in the queue until a pause or an end-of-queue condition is encountered. When a pause occurs, queue execution stops until the timer interval elapses again, and queue execution continues. When queue execution reaches an end-of-queue situation, the single-scan enable bit is cleared. Set the single-scan enable bit again to allow another scan of the queue to be initiated by the interval timer.

The interval timer generates a trigger event whenever the time interval elapses. The trigger event may cause queue execution to continue following a pause or may be considered a trigger overrun. Once queue execution is completed, the single-scan enable bit must be set again to allow the timer to count again.

Normally, only one queue is enabled for interval timer single-scan mode, and the timer will reset at the end-of-queue. However, if both queues are enabled for either single-scan or continuous interval timer mode, the end-of-queue condition will not reset the timer while the other queue is active. In this case, the timer will reset when both queues have reached end-of-queue. See [19.10.9 Periodic/Interval Timer](#) for a definition of interval timer reset conditions.

The interval timer single-scan mode can be used in applications that need coherent results. For example:

- When it is necessary that all samples are guaranteed to be taken during the same scan of the analog pins
- When the interrupt rate in the periodic timer continuous-scan mode would be too high
- In sensitive battery applications, where the interval timer single-scan mode uses less power than the software-initiated continuous-scan mode

### 19.10.7 Continuous-Scan Modes

A continuous-scan queue operating mode is used to execute multiple passes through a sequence of conversions defined by a queue. By programming the MQ1 field in QACR1 or the MQ2 field in QACR2, these modes can be selected:

- Software-initiated continuous-scan mode
- Externally triggered continuous-scan mode
- Externally gated continuous-scan mode
- Periodic timer continuous-scan mode

**NOTE:** *Queue 2 cannot be programmed for externally gated continuous-scan mode.*

When a queue is programmed for a continuous-scan mode, the single-scan enable bit in the queue control register does not have any meaning or effect. As soon as the queue operating mode is programmed, the selected trigger event can initiate queue execution.

In the case of software-initiated continuous-scan mode, the trigger event is generated internally and queue execution begins immediately. In the other continuous-scan queue operating modes, the selected trigger event must occur before the queue can start. A trigger overrun is captured if a trigger event occurs during queue execution in the externally triggered continuous-scan mode or the periodic timer continuous-scan mode.

After queue execution is complete, the queue status is shown as idle. Because the continuous-scan queue operating modes allow the entire queue to be scanned multiple times, software involvement is not needed for queue execution to continue from the idle state. The next trigger event causes queue execution to begin again, starting with the first CCW in the queue.

**NOTE:** *In continuous-scan modes, all samples are guaranteed to be taken during one pass through the queue (coherently), except when a queue 1 trigger event halts queue 2 execution. The time between consecutive conversions has been designed to be consistent. However, for queues that end with a CCW containing the EOQ code (channel 63), the time*

*between the last queue conversion and the first queue conversion requires one additional CCW fetch cycle. Continuous samples are not coherent at this boundary.*

*In addition, the time from trigger to first conversion cannot be guaranteed, because it is a function of clock synchronization, programmable trigger events, queue priorities, and so on.*

#### 19.10.7.1 Software-Initiated Continuous-Scan Mode

When software-initiated continuous-scan mode is selected, the trigger event is generated automatically by the QADC. Queue execution begins immediately. If a pause is encountered, another trigger event is generated internally, and execution continues without pausing. When the end-of-queue is reached, another internal trigger event is generated and queue execution restarts at the beginning of the queue.

While the time to internally generate and act on a trigger event is very short, the queue status field can be read as momentarily indicating that the queue is idle. The trigger overrun flag is never set while in software-initiated continuous-scan mode.

The software-initiated continuous-scan mode keeps the result registers updated more frequently than any of the other queue operating modes. The result table can always be read to get the latest converted value for each channel. The channels scanned are kept up to date by the QADC without software involvement.

The software-initiated continuous-scan mode may be chosen for either queue, but is normally used only with queue 2. When software-initiated continuous-scan mode is chosen for queue 1, that queue operates continuously and queue 2, being lower in priority, never gets executed. The short interval of time between a queue 1 completion and the subsequent trigger event is not sufficient to allow queue 2 execution to begin.

The software-initiated continuous-scan mode is a useful choice with queue 2 for converting channels that do not need to be synchronized to anything or for slow-to-change analog channels. Interrupts are normally not used with the software-initiated continuous-scan mode. Rather, the

latest conversion results can be read from the result table at any time. Once initiated, software action is not needed to sustain conversions of channel.

#### 19.10.7.2 Externally Triggered Continuous-Scan Mode

The QADC provides external trigger pins for both queues. When externally triggered continuous-scan mode is selected, a transition on the associated external trigger pin initiates queue execution. The polarity of the external trigger signal is programmable, so that a mode which begins queue execution on the rising or falling edge can be selected. Each CCW is read and the indicated conversions are performed until an end-of-queue condition is encountered. When the next external trigger edge is detected, queue execution begins again automatically. Software involvement is not needed between trigger events.

When a pause bit is encountered in externally triggered continuous-scan mode, another trigger event is required for queue execution to continue. Software involvement is not needed for queue execution to continue from the paused state.

Some applications need to synchronize the sampling of analog channels to external events. There are cases when it is not possible to use software initiation of the queue scan sequence, because interrupt response times vary. Externally triggered continuous-scan mode is useful in these cases.

#### 19.10.7.3 Externally Gated Continuous-Scan Mode

The QADC provides external gating for queue 1 only. When externally gated continuous-scan mode is selected, the input level on the associated external trigger pin enables and disables queue execution. The polarity of the external gate signal is fixed so that a high level opens the gate and a low level closes the gate. Once the gate is open, each CCW is read and the indicated conversions are performed until the gate is closed. When the gate opens again, queue execution automatically restarts at the beginning of the queue. Software involvement is not needed between trigger events. If a pause in a CCW is encountered, the pause flag does not set, and execution continues without pausing.

The purpose of externally gated continuous-scan mode is to continuously collect digitized samples while the gate is open and to have the most recent samples available. It is up to the programmer to ensure that the gate is not opened so long that an end-of-queue is reached.

In the event that the queue completes before the gate closes, the CF1 flag will set, and the queue will roll over to the beginning and continue conversions until the gate closes. If the gate remains open and the CF1 flag is not cleared, when the queue completes a second time the TOR1 flag will set and the queue will roll-over again. The queue will continue to execute until the gate closes or the mode is disabled.

If the gate closes before queue 1 completes execution, the QADC stops and sets the PF1 bit to indicate an incomplete queue. The CWPQ1 field can be read to determine the last valid conversion in the queue. If the gate opens again, execution of queue 1 restarts. The start of queue 1 is always the first CCW in the CCW table. The condition of the gate is only sampled after each conversion during queue execution, so closing the gate for a period less than a conversion time interval does not guarantee the closure will be captured.

#### 19.10.7.4 Periodic Timer Continuous-Scan Mode

The QADC includes a dedicated periodic timer for initiating a scan sequence on queue 1 and/or queue 2. A programmable timer interval ranging from  $2^7$  to  $2^{17}$  times the QCLK period in binary multiples can be selected. The QCLK period is prescaled down from the MCU clock.

When a periodic timer continuous-scan mode is selected, the timer begins counting. After the programmed interval elapses, the timer generated trigger event starts the appropriate queue. The QADC automatically performs the conversions in the queue until an end-of-queue condition or a pause is encountered. When a pause occurs, the QADC waits for the periodic interval to expire again, then continues with the queue. Once EOQ has been detected, the next trigger event causes queue execution to restart with the first CCW in the queue.

The periodic timer generates a trigger event whenever the time interval elapses. The trigger event may cause queue execution to continue following a pause or queue completion or may be considered a trigger

overflow. As with all continuous-scan queue operating modes, software action is not needed between trigger events. Because both queues may be triggered by the periodic/interval timer, see **19.10.9 Periodic/Interval Timer** for a summary of periodic/interval timer reset conditions.

**19.10.8 QADC Clock (QCLK) Generation**

**Figure 19-42** is a block diagram of the clock subsystem. The QCLK provides the timing for the A/D converter state machine which controls the timing of the conversion. The QCLK is also the input to a 17-stage binary divider which implements the periodic/interval timer. To retain the specified analog conversion accuracy, the QCLK frequency ( $f_{QCLK}$ ) must be within the tolerance specified in **Table 23-8. QADC Conversion Specifications (Operating)**.

Before using the QADC, the prescaler must be initialized with values that put the QCLK within the specified range. Though most applications initialize the prescaler once and do not change it, write operations to the prescaler fields are permitted.

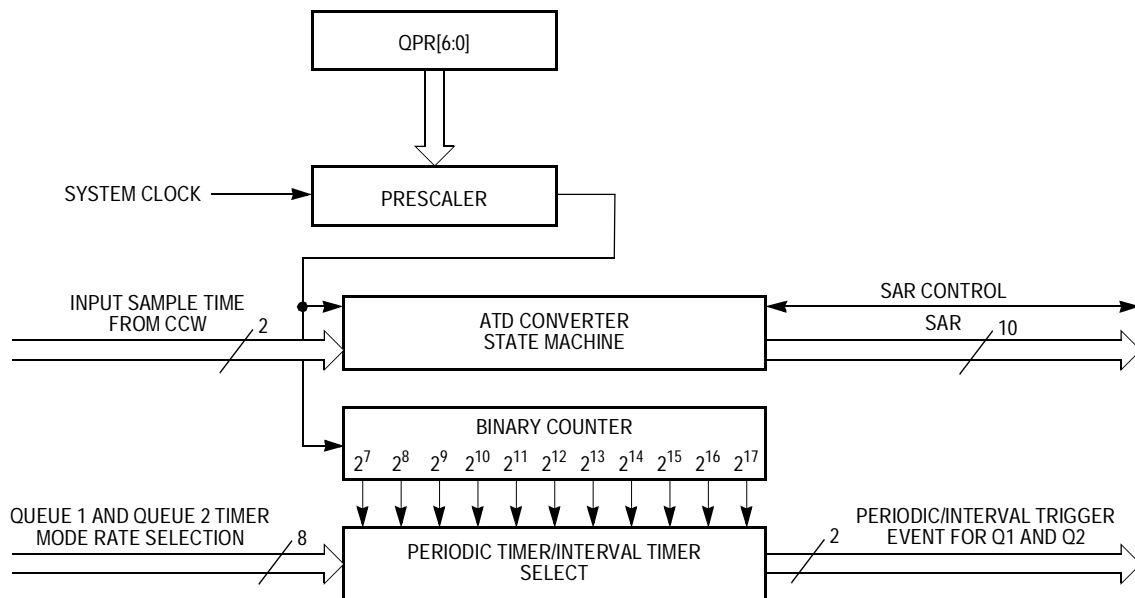

**Figure 19-42. QADC Clock Subsystem Functions**



## Queued Analog-to-Digital Converter (QADC)

**CAUTION:** *A change in the prescaler value while a conversion is in progress is likely to corrupt the result. Therefore, any prescaler write operation should be done only when both queues are in the disabled modes.*

To accommodate the wide range of the main MCU clock frequency, QCLK is generated by a programmable prescaler which divides the MCU system clock. To allow the A/D conversion time to be maximized across the spectrum of system clock frequencies, the QADC prescaler permits the QCLK frequency to be software selectable. The frequency of QCLK is set with the QPR field in QACR0.

The MCU system clock frequency is the basis of QADC timing. The QADC requires that the system clock frequency be at least twice the QCLK frequency.

### 19.10.9 Periodic/Interval Timer

The QADC periodic/interval timer can be used to generate trigger events at a programmable interval, initiating execution of queue 1 and/or queue 2. The periodic/interval timer stays reset under these conditions:

- Both queue 1 and queue 2 are programmed to any mode which does not use the periodic/interval timer.
- System reset is asserted.
- Stop mode is enabled.
- Debug mode is enabled.

**NOTE:** *Interval timer single-scan mode does not start the periodic/interval timer until the single-scan enable bit is set.*

These conditions will cause a pulsed reset of the periodic/interval timer during use:

- A queue 1 operating mode change to a mode which uses the periodic/interval timer, even if queue 2 is already using the timer
- A queue 2 operating mode change to a mode which uses the periodic/interval timer, provided queue 1 is not in a mode which uses the periodic/interval timer
- Roll over of the timer



During stop mode, the periodic/interval timer is held in reset. Because stop mode causes QACR1 and QACR2 to be reset to 0, a valid periodic or interval timer mode must be written after leaving stop mode to release the timer from reset.

When QADC debug mode is entered and a periodic or interval timer mode is selected, the timer counter is reset after the conversion in progress completes. When the periodic or interval timer mode has been enabled (the timer is counting), but a trigger event has not been issued, debug mode takes effect immediately, and the timer is held in reset. Removal of the QADC debug condition restarts the counter from the beginning. Refer to [19.5.1 Debug Mode](#) for more information.

#### 19.10.10 Conversion Command Word Table

The conversion command word (CCW) table is 64 half-word (128 byte) long RAM with 10 bits of each entry implemented. The CCW table is written by the user and is not modified by the QADC. Each CCW requests the conversion of one analog channel to a digital result. The CCW specifies the analog channel number, the input sample time, and whether the queue is to pause after the current CCW. The 10 implemented bits of the CCW can be read and written. The remaining six bits are unimplemented and read as 0s; write operations have no effect. Each location in the CCW table corresponds to a location in the result word table. When a conversion is completed for a CCW entry, the 10-bit result is written in the corresponding result word entry.

The beginning of queue 1 is the first location in the CCW table. The first location of queue 2 is specified by the beginning of queue 2 pointer field (BQ2) in QACR2. To dedicate the entire CCW table to queue 1, place queue 2 in disabled mode and write BQ2 to 64 or greater. To dedicate the entire CCW table to queue 2, place queue 1 in disabled mode and set BQ2 to the first location in the CCW table (CCW0).

**Figure 19-43** illustrates the operation of the queue structure.

Queued Analog-to-Digital Converter (QADC)

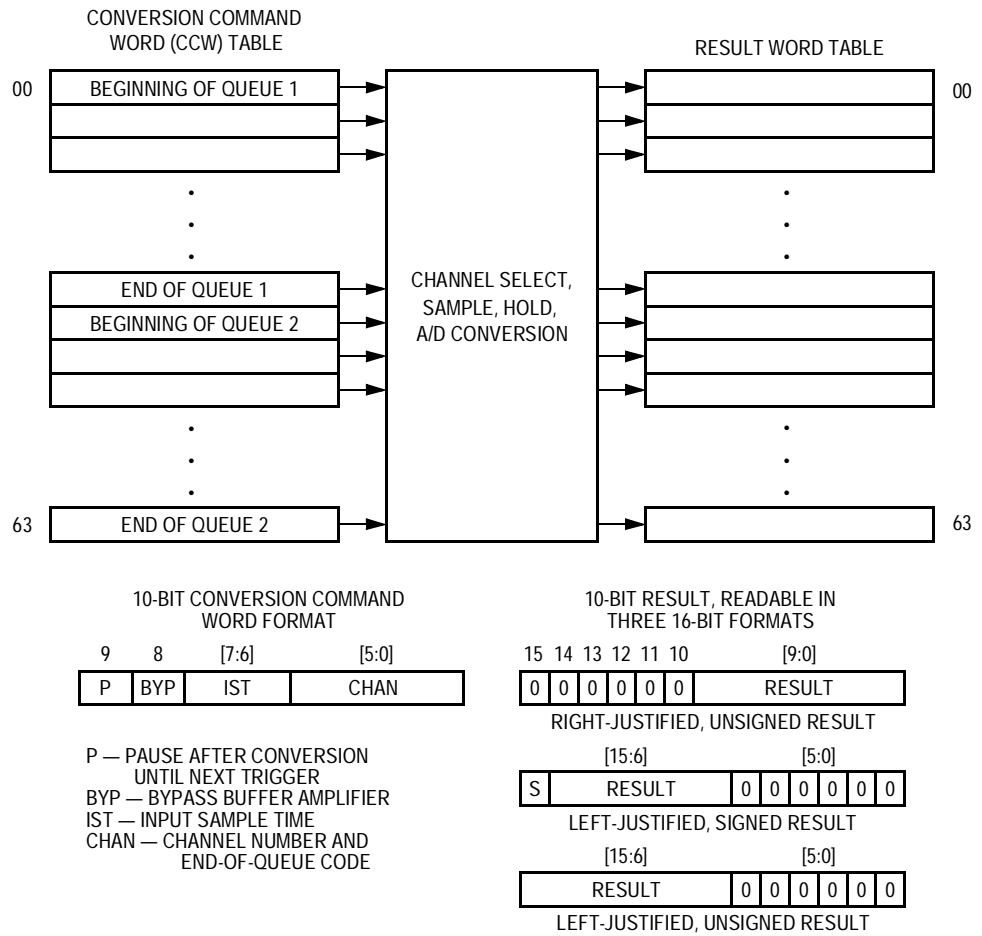

Figure 19-43. QADC Conversion Queue Operation

To prepare the QADC for a scan sequence, write to the CCW table to specify the desired channel conversions. The criteria for queue execution is established by selecting the queue operating mode. The queue operating mode determines what type of trigger event starts queue execution. A trigger event refers to any of the ways that cause the QADC to begin executing the CCWs in a queue or subqueue. An external trigger is only one of the possible trigger events.

A scan sequence may be initiated by:

- A software command
- Expiration of the periodic/interval timer
- An external trigger signal
- An external gated signal (queue 1 only)

The queue can be scanned in single pass or continuous fashion. When a single-scan mode is selected, the scan must be engaged by setting the single-scan enable bit. When a continuous-scan mode is selected, the queue remains active in the selected queue operating mode after the QADC completes each queue scan sequence.

During queue execution, the QADC reads each CCW from the active queue and executes conversions in three stages:

- Initial sample
- Final sample
- Resolution

During initial sample, a buffered version of the selected input channel is connected to the sample capacitor at the input of the sample buffer amplifier.

During the final sample period, the sample buffer amplifier is bypassed, and the multiplexer input charges the sample capacitor directly. Each CCW specifies a final input sample time of 2, 4, 8, or 16 QCLK cycles. When an analog-to-digital conversion is complete, the result is written to the corresponding location in the result word table. The QADC continues to sequentially execute each CCW in the queue until the end of the queue is detected or a pause bit is found in a CCW.

When the pause bit is set in the current CCW, the QADC stops execution of the queue until a new trigger event occurs. The pause status flag bit is set, and an interrupt may optionally be requested. After the trigger event occurs, the paused state ends, and the QADC continues to execute each CCW in the queue until another pause is encountered or the end of the queue is detected.

An end-of-queue condition occurs when:

- The CCW channel field is programmed with 63 to specify the end of the queue.
- The end-of-queue 1 is implied by the beginning of queue 2, which is specified by the BQ2 field in QACR2.
- The physical end of the queue RAM space defines the end of either queue.

## Queued Analog-to-Digital Converter (QADC)

When any of the end-of-queue conditions is recognized, a queue completion flag is set, and if enabled, an interrupt is requested. These situations prematurely terminate queue execution:

- Queue 1 is higher in priority than queue 2. When a trigger event occurs on queue 1 during queue 2 execution, the execution of queue 2 is suspended by aborting the execution of the CCW in progress, and queue 1 execution begins. When queue 1 execution is complete, queue 2 conversions restart with the first CCW entry in queue 2 or the first CCW of the queue 2 subqueue being executed when queue 2 was suspended. Alternately, conversions can restart with the aborted queue 2 CCW entry. The RESUME bit in QACR2 selects where queue 2 begins after suspension. By choosing to re-execute all of the suspended queue 2 CCWs (RESUME = 0), all of the samples are guaranteed to have been taken during the same scan pass. However, a high trigger event rate for queue 1 can prevent completion of queue 2. If this occurs, execution of queue 2 can begin with the aborted CCW entry (RESUME = 1).
- Any conversion in progress for a queue is aborted when that queue's operating mode is changed to disabled. Putting a queue into the disabled mode does not power down the converter.
- Changing a queue's operating mode to another valid mode aborts any conversion in progress. The queue restarts at its beginning once an appropriate trigger event occurs.
- For low-power operation, the stop bit can be set to prepare the module for a loss of clocks. The QADC aborts any conversion in progress when stop mode is entered.
- When the QADC debug bit is set and the CPU enters background debug mode, the QADC freezes at the end of the conversion in progress. After leaving debug mode, the QADC resumes queue execution beginning with the next CCW entry. Refer to [19.5.1 Debug Mode](#) for more information.

### 19.10.11 Result Word Table

The result word table is a 64 half-word (128 byte) long by 10-bit wide RAM. An entry is written by the QADC after completing an analog conversion specified by the corresponding CCW table entry. The result word table can be read or written, but in normal operation is only read to obtain analog conversions from the QADC. Unimplemented bits read as 0s and writes have no effect.

**NOTE:** *Although the result RAM can be written, some write operations, like bit manipulation, may not operate as expected because the hardware cannot access a true 16-bit value.*

While there is only one result word table, the half-word (16-bit) data can be accessed in three different data formats:

- Right justified with 0s in the higher order unused bits
- Left justified with the most significant bit inverted to form a sign bit, and 0s in the unused lower order bits
- Left justified with 0s in the lower order unused bits

The left justified, signed format corresponds to a half-scale, offset binary, two's complement data format. The address used to read the result table determines the data alignment format. All write operations to the result word table are right justified.

## 19.11 Pin Connection Considerations

The QADC requires accurate, noise-free input signals for proper operation. This section discusses the design of external circuitry to maximize QADC performance.

### 19.11.1 Analog Reference Pins

No A/D converter can be more accurate than its analog reference. Any noise in the reference can result in at least that much error in a conversion. The reference for the QADC, supplied by pins  $V_{RH}$  and  $V_{RL}$ , should be low-pass filtered from its source to obtain a noise-free, clean signal. In many cases, simple capacitive bypassing may suffice. In

Queued Analog-to-Digital Converter (QADC)

extreme cases, inductors or ferrite beads may be necessary if noise or RF energy is present. Series resistance is not advisable, because there is an effective DC current required from the reference voltage by the internal resistor string in the RC DAC array. External resistance may introduce error in this architecture under certain conditions. Any series devices in the filter network should contain a minimum amount of DC resistance.

For accurate conversion results, the analog reference voltages must be within the limits defined by  $V_{DDA}$  and  $V_{SSA}$ , as explained in this subsection.

19.11.2 Analog Power Pins

The analog supply pins ( $V_{DDA}$  and  $V_{SSA}$ ) define the limits of the analog reference voltages ( $V_{RH}$  and  $V_{RL}$ ) and of the analog multiplexer inputs. **Figure 19-44** is a diagram of the analog input circuitry.

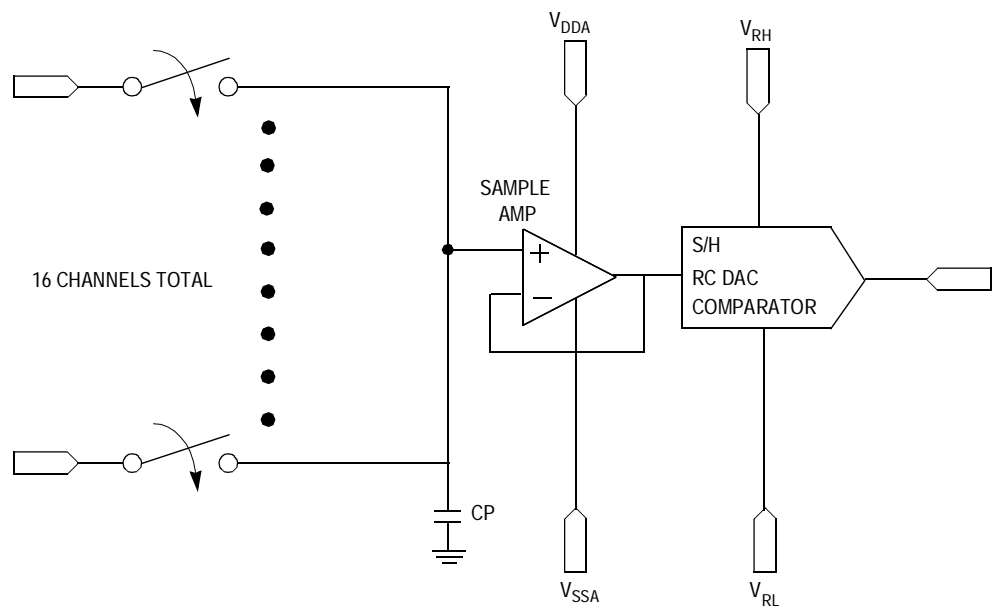
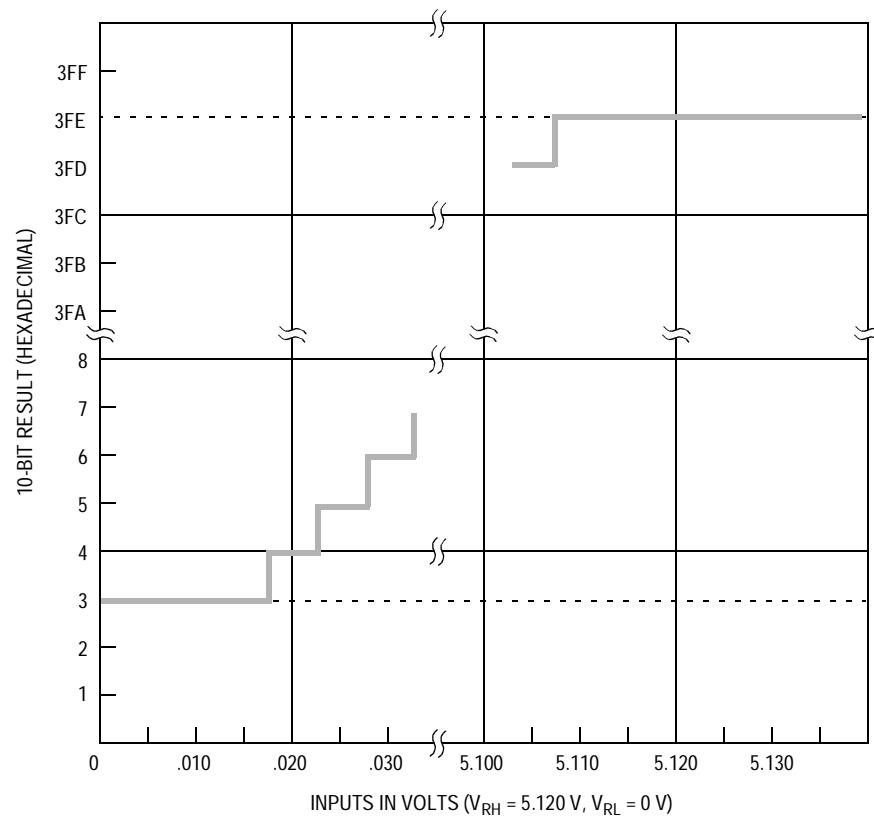

Figure 19-44. Equivalent Analog Input Circuitry

Because the sample amplifier is powered by  $V_{DDA}$  and  $V_{SSA}$ , it can accurately transfer input signal levels up to but not exceeding  $V_{DDA}$  and down to but not below  $V_{SSA}$ . If the input signal is outside of this range, the output from the sample amplifier is clipped.

In addition,  $V_{RH}$  and  $V_{RL}$  must be within the range defined by  $V_{DDA}$  and  $V_{SSA}$ . As long as  $V_{RH}$  is less than or equal to  $V_{DDA}$ , and  $V_{RL}$  is greater than or equal to  $V_{SSA}$ , and the sample amplifier has accurately transferred the input signal, resolution is ratiometric within the limits defined by  $V_{RL}$  and  $V_{RH}$ . If  $V_{RH}$  is greater than  $V_{DDA}$ , the sample amplifier can never transfer a full-scale value. If  $V_{RL}$  is less than  $V_{SSA}$ , the sample amplifier can never transfer a 0 value.

**Figure 19-45** shows the results of reference voltages outside the range defined by  $V_{DDA}$  and  $V_{SSA}$ . At the top of the input signal range,  $V_{DDA}$  is 10 mV lower than  $V_{RH}$ . This results in a maximum obtainable 10-bit conversion value 0x03fe. At the bottom of the signal range,  $V_{SSA}$  is 15 mV higher than  $V_{RL}$ , resulting in a minimum obtainable 10-bit conversion value of 0x0003.



**Figure 19-45. Errors Resulting from Clipping**

**Queued Analog-to-Digital Converter (QADC)**

**19.11.3 Conversion Timing Schemes**

This section contains some conversion timing examples. **Figure 19-46** shows the timing for basic conversions where it is assumed that:

- Q1 begins with CCW0 and ends with CCW3.
- CCW0 has pause bit set.
- CCW1 does not have pause bit set.
- External trigger rising edge for Q1
- CCW4 = BQ2 and Q2 is disabled.
- Q1 RES shows relative result register updates.

Recall that when QS = 0, both queues are disabled; when QS = 8, queue 1 is active and queue 2 is idle; and when QS = 4; queue 1 is paused and queue 2 is disabled.

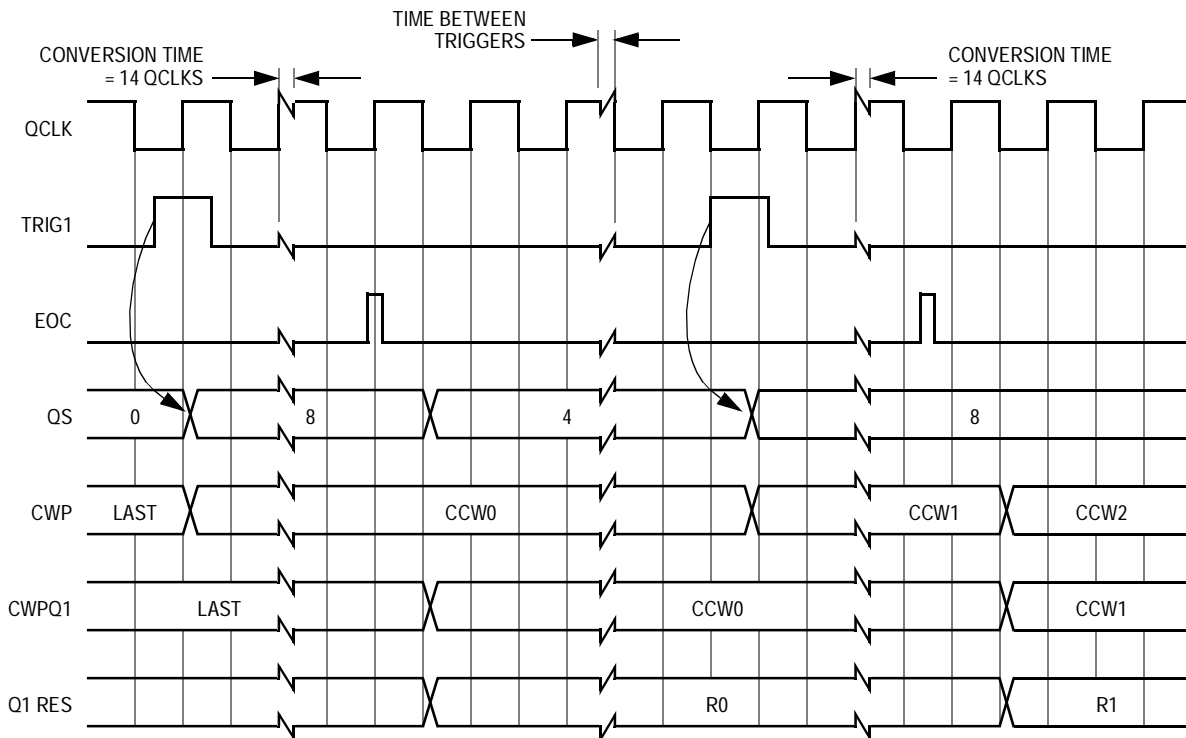

**Figure 19-46. External Positive Edge Trigger Mode Timing with Pause**



A time separator is provided between the triggers and the end of conversion (EOC). The relationship to QCLK displayed is not guaranteed.

CWPQ1 and CWPQ2 typically lag CWP and only match CWP when the associated queue is inactive. Another way to view CWPQ1 and CWPQ2 is that these registers update when EOC triggers the write to the result register.

For the CCW with the pause bit set (CCW0), CWP does not increment until triggered. For the CCW with the pause bit clear (CCW1), the CWP increments with the EOC.

The conversion results Q1 RESx show the result associated with CCWx, such that R0 represents the result associated with CCW0.

**Figure 19-47** shows the timing for conversions in externally gated single-scan with same assumptions in example 1 except:

- No pause bits set in any CCW
- Externally gated single scan mode for Q1
- Single scan enable bit (SSE1) is set.

When the gate closes and opens again, the conversions start with the first CCW in Q1.

When the gate closes, the active conversion completes before the queue goes idle.

When Q1 completes, both the CF1 bit sets and the SSE bit clears.

In this mode, the PF1 bit sets to reflect that a gate closing occurred before the queue completed.

**Figure 19-48** shows the timing for conversions in externally gated continuous scan mode with the same assumptions as in **Figure 19-47**.

At the end of Q1, the completion flag CF1 sets and the queue restarts. If the queue starts a second time and completes, the trigger overrun flag TOR1 sets.

Queued Analog-to-Digital Converter (QADC)

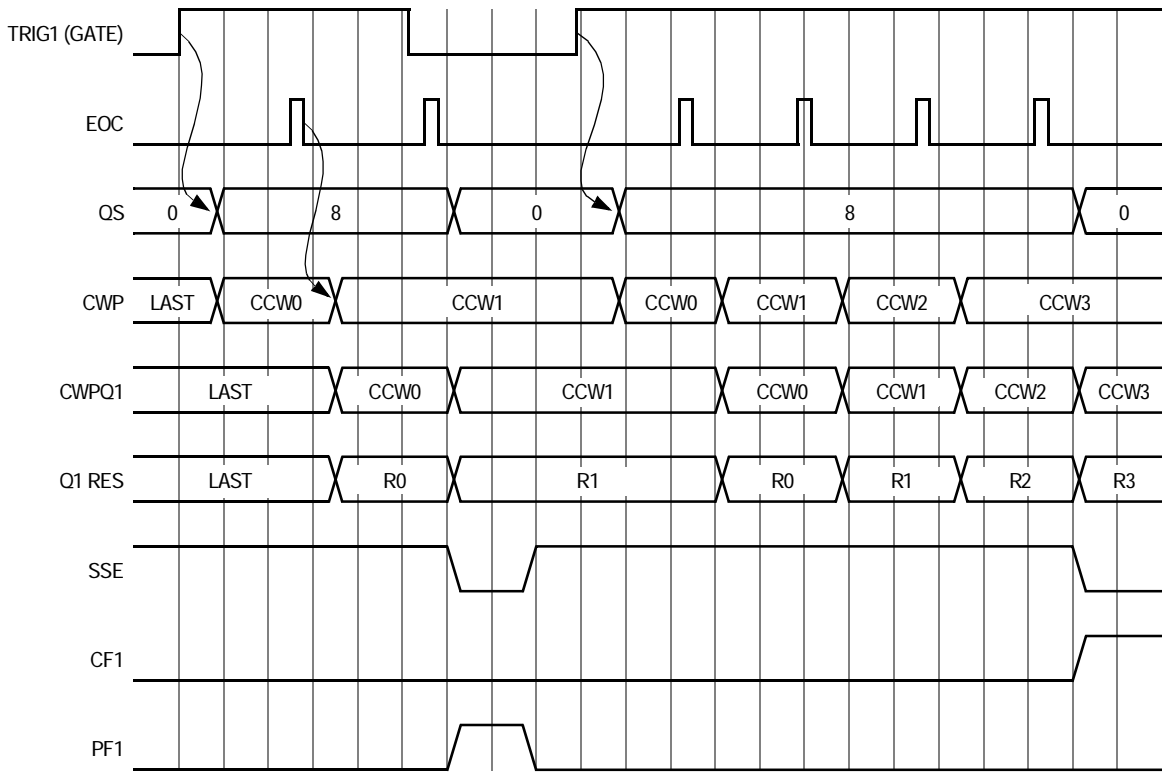

Figure 19-47. Gated Mode, Single Scan Timing

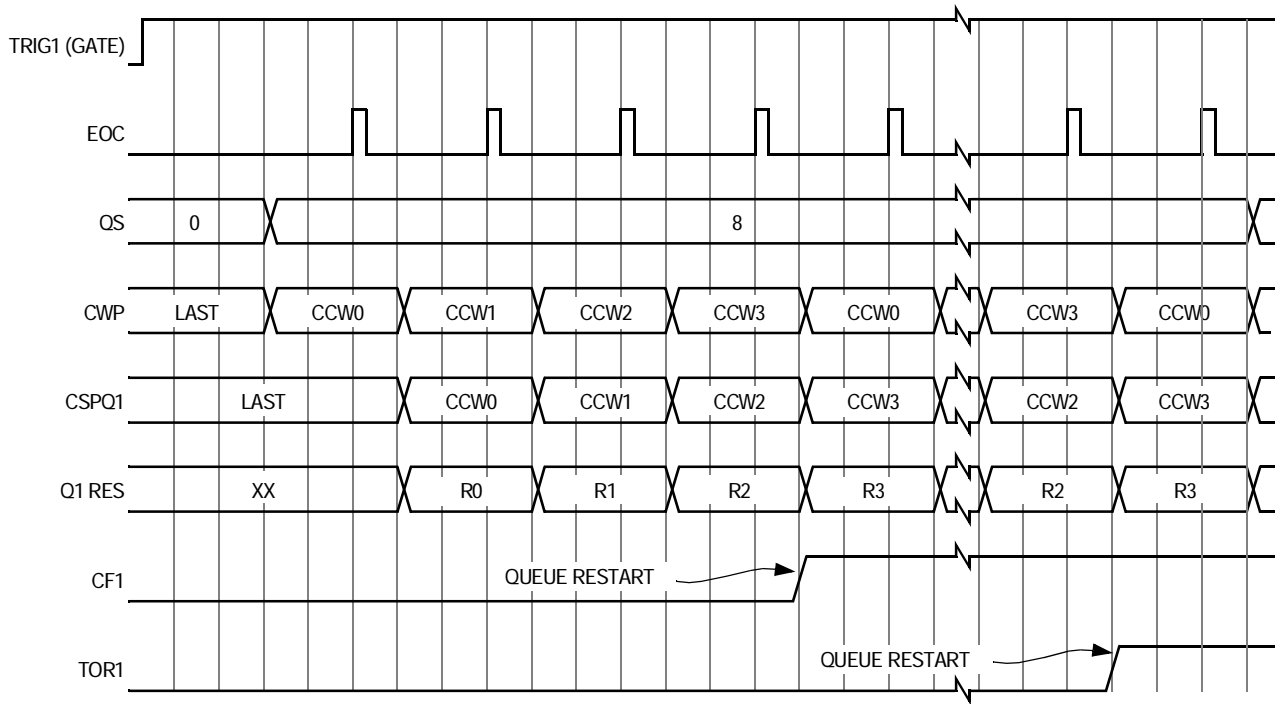

Figure 19-48. Gated Mode, Continuous Scan Timing

#### 19.11.4 Analog Supply Filtering and Grounding

Two important factors influencing performance in analog integrated circuits are supply filtering and grounding. Generally, digital circuits use bypass capacitors on every  $V_{DD}/V_{SS}$  pin pair. This applies to analog subsystems and submodules also. Equally important as bypassing is the distribution of power and ground.

Analog supplies should be isolated from digital supplies as much as possible. This necessity stems from the higher performance requirements often associated with analog circuits. Therefore, deriving an analog supply from a local digital supply is not recommended. However, if for cost reasons digital and analog power are derived from a common regulator, filtering of the analog power is recommended in addition to the bypassing of the supplies already mentioned. For example, an RC low pass filter could be used to isolate the digital and analog supplies when generated by a common regulator. If multiple high precision analog circuits are locally employed (for example, two A/D converters), the analog supplies should be isolated from each other as sharing supplies introduces the potential for interference between analog circuits.

Grounding is the most important factor influencing analog circuit performance in mixed signal systems (or in standalone analog systems). Close attention must be paid not to introduce additional sources of noise into the analog circuitry. Common sources of noise include ground loops, inductive coupling, and combining digital and analog grounds together inappropriately.

The problem of how and when to combine digital and analog grounds arises from the large transients which the digital ground must handle. If the digital ground is not able to handle the large transients, the associated current can return to ground through the analog ground. It is this excess current overflowing into the analog ground which causes performance degradation by developing a differential voltage between the true analog ground and the microcontroller's ground pins. The end result is that the ground observed by the analog circuit is no longer true ground and thus skews converter performance.

Queued Analog-to-Digital Converter (QADC)

Two similar approaches to improving or eliminating the problems associated with grounding excess transient currents involve star-point ground systems. One approach is to star-point the different grounds at the power supply origin, thus keeping the ground isolated. Refer to [Figure 19-49](#).

Another approach is to star-point the different grounds near the analog ground pin on the microcontroller by using small traces for connecting the non-analog grounds to the analog ground. The small traces are meant only to accommodate dc differences, not ac transients.

**NOTE:** *This star-point scheme still requires adequate grounding for digital and analog subsystems in addition to the star-point ground.*

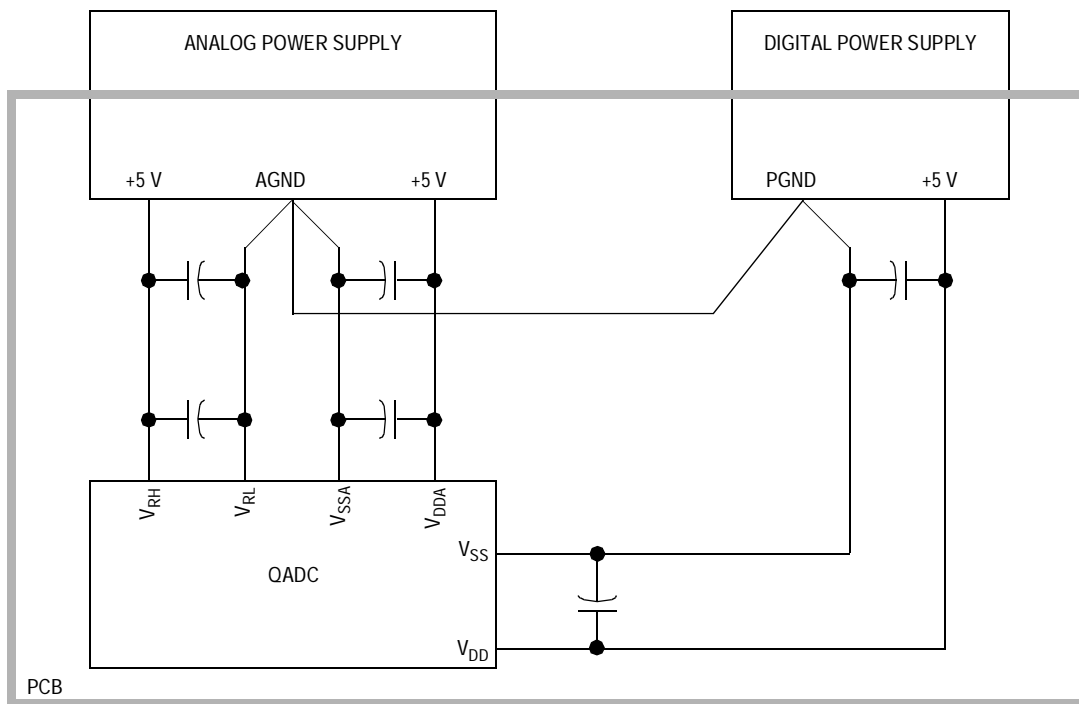

Figure 19-49. Star-Ground at the Point of Power Supply Origin

Other suggestions for PCB layout in which the QADC is employed include:

- Analog ground must be low impedance to all analog ground points in the circuit.
- Bypass capacitors should be as close to the power pins as possible.
- The analog ground should be isolated from the digital ground. This can be done by cutting a separate ground plane for the analog ground.
- Non-minimum traces should be utilized for connecting bypass capacitors and filters to their corresponding ground/power points.
- Minimum distance for trace runs when possible.

### 19.11.5 Accommodating Positive/Negative Stress Conditions

Positive or negative stress refers to conditions which exceed nominally defined operating limits. Examples include applying a voltage exceeding the normal limit on an input (for example, voltages outside of the suggested supply/reference ranges) or causing currents into or out of the pin which exceed normal limits. QADC specific considerations are voltages greater than  $V_{DDA}$  or less than  $V_{SSA}$  applied to an analog input which cause excessive currents into or out of the input. Refer to [Table 23-6. QADC Absolute Maximum Ratings](#) and [Table 23-7. QADC Electrical Specifications \(Operating\)](#) for more information on exact magnitudes.

Either stress conditions can potentially disrupt conversion results on neighboring inputs. Parasitic devices, associated with CMOS processes, can cause an immediate disruptive influence on neighboring pins. Common examples of parasitic devices are diodes to substrate and bipolar devices with the base terminal tied to substrate ( $V_{SS}/V_{SSA}$  ground). Under stress conditions, current injected on an adjacent pin can cause errors on the selected channel by developing a voltage drop across the selected channel's impedances.

Queued Analog-to-Digital Converter (QADC)

Figure 19-50 shows an active parasitic bipolar NPN transistor when an input pin is subjected to negative stress conditions. Figure 19-51 shows positive stress conditions can activate a similar PNP transistor.

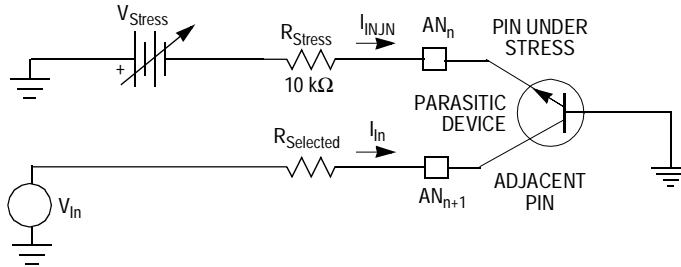

Figure 19-50. Input Pin Subjected to Negative Stress

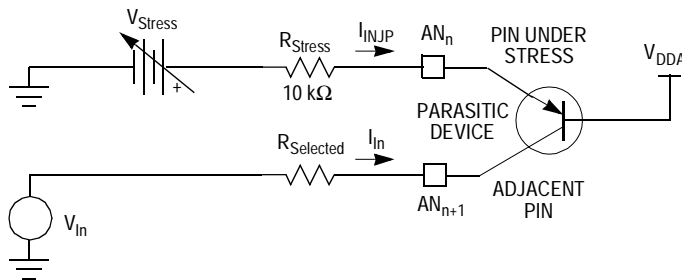

Figure 19-51. Input Pin Subjected to Positive Stress

The current into the pin ( $I_{INJN}$  or  $I_{INJP}$ ) under negative or positive stress is determined by these equations:

$$I_{INJN} = \frac{-(V_{Stress} - V_{BE})}{R_{Stress}}$$

$$I_{INJP} = \frac{V_{Stress} - V_{EB} - V_{DDA}}{R_{Stress}}$$

Where:

$V_{Stress}$  = Adjustable voltage source

$V_{EB}$  = Parasitic PNP emitter/base voltage

$V_{BE}$  = Parasitic NPN base/emitter voltage

$R_{Stress}$  = Source impedance (10 kΩ resistor in Figure 19-50 and Figure 19-51 on stressed channel)

$R_{Selected}$  = Source impedance on channel selected for conversion

The current into ( $I_{in}$ ) the neighboring pin is determined by the  $K_N$  (current coupling ratio) of the parasitic bipolar transistor ( $K_N \ll 1$ ). The  $I_{in}$  can be expressed by this equation:

$$I_{in} = -K_N * I_{INJ}$$

Where:

$I_{INJ}$  is either  $I_{INJN}$  or  $I_{INJP}$ .

A method for minimizing the impact of stress conditions on the QADC is to strategically allocate QADC inputs so that the lower accuracy inputs are adjacent to the inputs most likely to see stress conditions.

Also, suitable source impedances should be selected to meet design goals and minimize the effect of stress conditions.

#### 19.11.6 Analog Input Considerations

The source impedance of the analog signal to be measured and any intermediate filtering should be considered whether external multiplexing is used or not. **Figure 19-52** shows the connection of eight typical analog signal sources to one QADC analog input pin through a separate multiplexer chip. Also, an example of an analog signal source connected directly to a QADC analog input channel is displayed.

Queued Analog-to-Digital Converter (QADC)

Freescale Semiconductor, Inc.

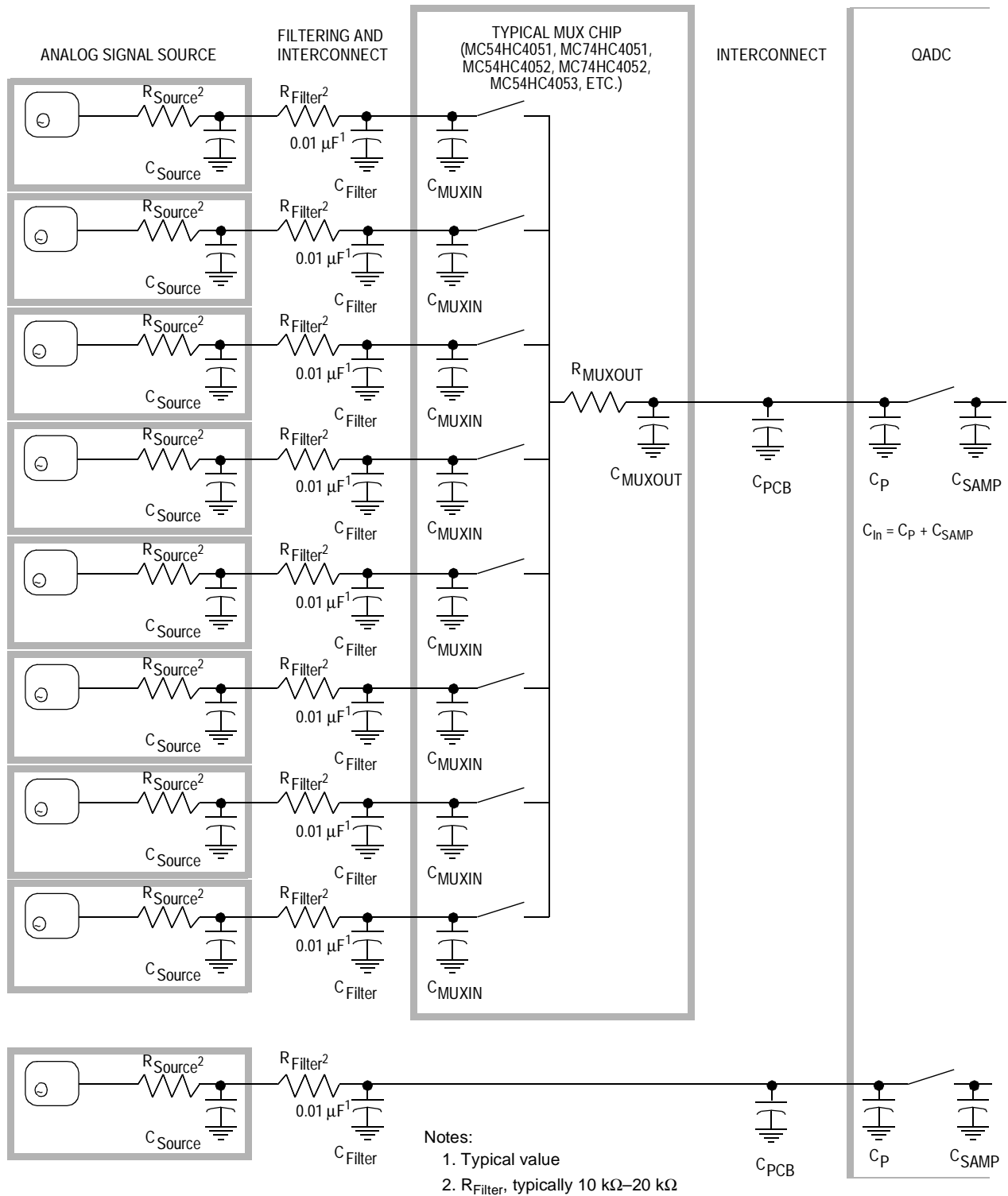

Figure 19-52. External Multiplexing of Analog Signal Sources



### 19.11.7 Analog Input Pins

Analog inputs should have low ac impedance at the pins. Low ac impedance can be realized by placing a capacitor with good high frequency characteristics at the input pin of the part. Ideally, that capacitor should be as large as possible (within the practical range of capacitors that still have good high-frequency characteristics). This capacitor has two effects:

- It helps attenuate any noise that may exist on the input.
- It sources charge during the sample period when the analog signal source is a high-impedance source.

Series resistance can be used with the capacitor on an input pin to implement a simple RC filter. The maximum level of filtering at the input pins is application dependent and is based on the bandpass characteristics required to accurately track the dynamic characteristics of an input. Simple RC filtering at the pin may be limited by the source impedance of the transducer or circuit supplying the analog signal to be measured. (See [19.11.7.2 Error Resulting from Leakage](#).) In some cases, the size of the capacitor at the pin may be very small.

**Figure 19-53** is a simplified model of an input channel. Refer to this model in the following discussion of the interaction between the external circuitry and the circuitry inside the QADC.

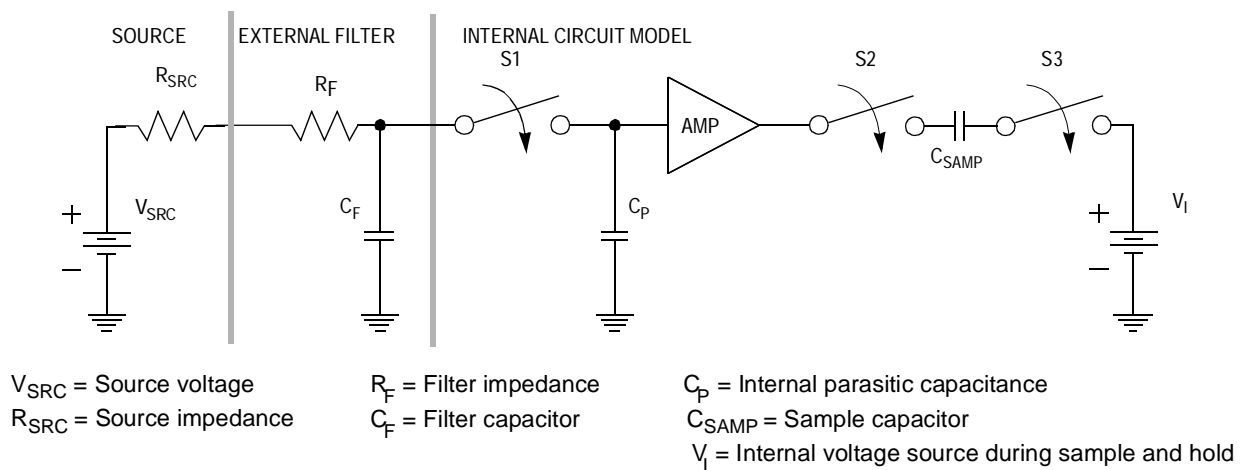

**Figure 19-53. Electrical Model of an A/D Input Pin**

## Queued Analog-to-Digital Converter (QADC)

In **Figure 19-53**,  $R_F$ ,  $R_{SRC}$ , and  $C_F$  comprise the external filter circuit.  $C_P$  is the internal parasitic capacitor.  $C_{Samp}$  is the capacitor array used to sample and hold the input voltage.  $V_I$  is an internal voltage source used to provide charge to  $C_{Samp}$  during sample phase.

The following paragraphs provide a simplified description of the interaction between the QADC and the user's external circuitry. This circuitry is assumed to be a simple RC low-pass filter passing a signal from a source to the QADC input pin. These simplifying assumptions are made:

- The external capacitor is perfect (no leakage, no significant dielectric absorption characteristics, etc.).
- All parasitic capacitance associated with the input pin is included in the value of the external capacitor.
- Inductance is ignored.
- The "on" resistance of the internal switches is 0 ohms and the "off" resistance is infinite.

#### 19.11.7.1 Settling Time for the External Circuit

The values for  $R_{SRC}$ ,  $R_F$ , and  $C_F$  in the user's external circuitry determine the length of time required to charge  $C_F$  to the source voltage level ( $V_{SRC}$ ). At time  $t = 0$ ,  $V_{SRC}$  changes in **Figure 19-53** while S1 is open, disconnecting the internal circuitry from the external circuitry. Assume that the initial voltage across  $C_F$  is 0. As  $C_F$  charges, the voltage across it is determined by the equation, where  $t$  is the total charge time:

$$V_{CF} = V_{SRC} (1 - e^{-t/(R_F + R_{SRC}) C_F})$$

As  $t$  approaches infinity,  $V_{CF}$  will equal  $V_{SRC}$ . (This assumes no internal leakage.) With 10-bit resolution, 1/2 of a count is equal to 1/2048 full-scale value. Assuming worst case ( $V_{SRC}$  = full scale), **Table 19-14** shows the required time for  $C_F$  to charge to within 1/2 of a count of the actual source voltage during 10-bit conversions. **Table 19-14** is based on the RC network in **Figure 19-53**.

**NOTE:** *The following times are completely independent of the A/D converter architecture (assuming the QADC is not affecting the charging).*

**Table 19-14. External Circuit Settling Time to 1/2 LSB**

Filter Capacitor ( $C_F$ )	Source Resistance ( $R_F + R_{SRC}$ )			
	100 $\Omega$	1 k $\Omega$	10 k $\Omega$	100 k $\Omega$
1 $\mu$ F	760 $\mu$ s	7.6 ms	76 ms	760 ms
0.1 $\mu$ F	76 $\mu$ s	760 $\mu$ s	7.6 ms	76 ms
0.01 $\mu$ F	7.6 $\mu$ s	76 $\mu$ s	760 $\mu$ s	7.6 ms
0.001 $\mu$ F	760 ns	7.6 $\mu$ s	76 $\mu$ s	760 $\mu$ s
100 pF	76 ns	760 ns	7.6 $\mu$ s	76 $\mu$ s

The external circuit described in [Table 19-14](#) is a low-pass filter. Measurements of an AC component of the external signal must take the characteristics of this filter into account.

#### 19.11.7.2 Error Resulting from Leakage

A series resistor limits the current to a pin therefore, input leakage acting through a large source impedance can degrade A/D accuracy. The maximum input leakage current is specified in [Table 23-7. QADC Electrical Specifications \(Operating\)](#). Input leakage is greater at higher operating temperatures. In the temperature range from 125°C to 50°C, the leakage current is halved for every 8°C to 12°C reduction in temperature.

Assuming  $V_{RH} - V_{RL} = 5.12$  V, 1 count (with 10-bit resolution) corresponds to 5 mV of input voltage. A typical input leakage of 200 nA acting through 10 k $\Omega$  of external series resistance results in an error of 0.4 count (2.0 mV). If the source impedance is 100 k $\Omega$  and a typical leakage of 100 nA is present, an error of 2 counts (10 mV) is introduced.

In addition to internal junction leakage, external leakage (for example, if external clamping diodes are used) and charge sharing effects with internal capacitors also contribute to the total leakage current.

[Table 19-15](#) illustrates the effect of different levels of total leakage on accuracy for different values of source impedance. The error is listed in terms of 10-bit counts.

**CAUTION:** Leakage below 200 nA is obtainable only within a limited temperature range.

**Table 19-15. Error Resulting from Input Leakage ( $I_{Off}$ )**

Source Impedance	Leakage Value (10-Bit Conversions)			
	100 nA	200 nA	500 nA	1000 nA
1 k $\Omega$	—	—	0.1 counts	0.2 counts
10 k $\Omega$	0.2 counts	0.4 counts	1 counts	2 counts
100 k $\Omega$	2 counts	4 count	10 counts	20 counts

## 19.12 Interrupts

The four interrupt lines are outputs of the module and have no priority or arbitration within the module.

### 19.12.1 Interrupt Operation

QADC inputs can be monitored by polling or by using interrupts. When interrupts are not needed, the completion flag and the pause flag for each queue can be monitored in the Status Register (QASR0). In other words, flag bits can be polled to determine when new results are available.

**Table 19-16** shows the status flag and interrupt enable bits which correspond to queue 1 and queue 2 activity.

**Table 19-16. QADC Status Flags and Interrupt Sources**

Queue	Queue Activity	Status Flag	Interrupt Enable Bit
Queue 1	Result written for last CCW in queue 1	CF1	CIE1
	Result written for a CCW with pause bit set in queue 1	PF1	PIE1
Queue 2	Result written for last CCW in queue 2	CF2	CIE2
	Result written for a CCW with pause bit set in queue 2	PF2	PIE2

If interrupts are enabled for an event, the QADC requests interrupt service when the event occurs. Using interrupts does not require continuously polling the status flags to see if an event has taken place; however, status flags must be cleared after an interrupt is serviced, in order to remove the interrupt request.

In both polled and interrupt-driven operating modes, status flags must be re-enabled after an event occurs. Flags are re-enabled by clearing the appropriate QASR0 bits in a particular sequence. QASR0 must first be read, then 0s must be written to the flags that are to be cleared. If a new event occurs between the time that the register is read and the time that it is written, the associated flag is not cleared.

### 19.12.2 Interrupt Sources

The QADC includes four sources of interrupt requests, each of which is separately enabled. Each time the result is written for the last conversion command word (CCW) in a queue, the completion flag for the corresponding queue is set, and when enabled, an interrupt is requested. In the same way, each time the result is written for a CCW with the pause bit set, the queue pause flag is set, and when enabled, an interrupt is requested. Refer to [Table 19-16](#).

The pause and complete interrupts for queue 1 and queue 2 have separate interrupt vector levels, so that each source can be separately serviced.



## Section 20. External Bus Interface Module (EBI)

### 20.1 Contents

20.2	Introduction . . . . .	528
20.3	Signal Descriptions . . . . .	529
20.3.1	Data Bus (D[31:0]) . . . . .	530
20.3.2	Show Cycle Strobe ( $\overline{\text{SHS}}$ ) . . . . .	530
20.3.3	Transfer Acknowledge ( $\overline{\text{TA}}$ ) . . . . .	530
20.3.4	Transfer Error Acknowledge ( $\overline{\text{TEA}}$ ) . . . . .	530
20.3.5	Emulation Mode Chip Selects (CSE[1:0]) . . . . .	530
20.3.6	Transfer Code (TC[2:0]) . . . . .	531
20.3.7	Read/Write (R/W) . . . . .	531
20.3.8	Address Bus (A[22:0]) . . . . .	531
20.3.9	Enable Byte ( $\overline{\text{EB}}[3:0]$ ) . . . . .	531
20.3.10	Chip Selects ( $\overline{\text{CS}}[3:0]$ ) . . . . .	531
20.3.11	Output Enable ( $\overline{\text{OE}}$ ) . . . . .	531
20.3.12	Transfer Size (TSIZ[1:0]) . . . . .	532
20.3.13	Processor Status (PSTAT[3:0]) . . . . .	532
20.4	Memory Map and Registers . . . . .	532
20.5	Operand Transfer . . . . .	532
20.6	Enable Byte Pins ( $\overline{\text{EB}}[3:0]$ ) . . . . .	534
20.7	Bus Master Cycles . . . . .	534
20.7.1	Read Cycles . . . . .	535
20.7.1.1	State 1 (X1) . . . . .	536
20.7.1.2	Optional Wait States (X2W) . . . . .	536
20.7.1.3	State 2 (X2) . . . . .	536
20.7.2	Write Cycles . . . . .	537
20.7.2.1	State 1 (X1) . . . . .	538
20.7.2.2	Optional Wait States (X2W) . . . . .	538
20.7.2.3	State 2 (X2) . . . . .	538

20.8 Bus Exception Operation .....540

20.8.1 Transfer Error Termination.....540

20.8.2 Transfer Abort Termination .....540

20.9 Emulation Support .....540

20.9.1 Emulation Chip-Selects (CSE[1:0]) .....540

20.9.2 Internal Data Transfer Display (Show Cycles) .....541

20.9.3 Show Strobe (SHS) .....542

20.9.4 Transfer Code (TC[2:0]) .....543

20.9.5 Processor Status (PSTAT).....543

20.10 Bus Monitor.....545

20.11 Interrupts.....545

## 20.2 Introduction

The external bus interface (EBI) module is responsible for controlling the transfer of information between the internal M•CORE local bus and external address space. The external bus has 23 address lines and 32 data lines.

In master mode and emulation mode, the EBI functions as a bus master and allows internal bus cycles to access external resources. In single-chip mode, the EBI is active, but the external data bus is not available, and no external data or termination signals are transferred to the internal bus.

The EBI supports data transfers to both 32-bit and 16-bit ports. Chip-select channels are programmed to define the port size for specific address ranges. When no chip-select is active during an external data transfer, the port size is defaults to 32 bits.

The EBI supports a variable length external bus cycle to accommodate the access speed of any device. During an external data transfer, the EBI drives the address pins, byte enable pins, output enable pins, size pins, and read/write pins. Wait states are inserted until the bus cycle is terminated by the assertion of the internal transfer acknowledge signal by a chip-select channel or by the assertion of the external  $\overline{TA}$  or  $\overline{TEA}$  pins. The minimum external bus cycle is one clock.



The EBI may drive the address, size, and read/write pins during internal data transfers if show cycles is enabled, but the output enable and byte enable pins are not asserted.

Only internal sources can terminate internal data transfers. Chip-select channels, external  $\overline{TA}$  assertion, and external  $\overline{TEA}$  assertion cannot terminate internal data transfers.

## 20.3 Signal Descriptions

**Table 20-1** provides an overview of the signal properties which are discussed in this subsection.

**Table 20-1. Signal Properties**

Name	Port	Function	Pullup
D[31:0]	PA, PB, PC, PD	Data bus	—
$\overline{SHS}$	PE7	Show cycle strobe	Active
$\overline{TA}$	PE6	Transfer acknowledge	Active
$\overline{TEA}$	PE5	Transfer error acknowledge	Active
CSE[1:0]	PE[4:3]	Emulation chip selects	Active
TC[2:0]	PE[2:0]	Transfer code	Active
R/ $\overline{W}$	PF7	Read/write	Active
A[22:0]	PF[6:0], PG, PH	Address bus	Active
EB[3:0]	PI[7:4]	Enable byte	Active
$\overline{CS}$ [3:0]	PI[3:0]	Chip selects	Active
$\overline{OE}$	—	Output enable	—
TSIZ[1:0]	—	Transfer size	—
PSTAT[3:0]	—	Processor status	—

### 20.3.1 Data Bus (D[31:0])

The three-state bidirectional data bus (D[31:0]) signals are the general-purpose data path between the microcontroller unit (MCU) and all other devices.

### 20.3.2 Show Cycle Strobe ( $\overline{\text{SHS}}$ )

In master and emulation modes, show cycle strobe ( $\overline{\text{SHS}}$ ) is the strobe for capturing address, controls, and data during show cycles. In master mode this default functionality can be overridden to make the pin function as digital I/O. See [12.4.2.6 Port E Pin Assignment Register](#) and [Table 12-3. Ports A–I Supported Pin Functions](#). In single-chip mode, the  $\overline{\text{SHS}}$  pin is configured as digital I/O (PE7) by default.

### 20.3.3 Transfer Acknowledge ( $\overline{\text{TA}}$ )

The transfer acknowledge ( $\overline{\text{TA}}$ ) signal indicates that the external data transfer is complete. During a read cycle, when the processor recognizes  $\overline{\text{TA}}$ , it latches the data and then terminates the bus cycle. During a write cycle, when the processor recognizes  $\overline{\text{TA}}$ , the bus cycle is terminated.  $\overline{\text{TA}}$  is an input in master and emulation modes. In single-chip mode, the  $\overline{\text{TA}}$  pin is configured as digital I/O (PE6) by default.

### 20.3.4 Transfer Error Acknowledge ( $\overline{\text{TEA}}$ )

The transfer error acknowledge ( $\overline{\text{TEA}}$ ) indicates an error condition exists for the bus transfer. The bus cycle is terminated and the CPU begins execution of the access error exception.  $\overline{\text{TEA}}$  is an input in master and emulation modes. In single-chip mode the  $\overline{\text{TEA}}$  pin is configured a digital I/O (PE5) by default.

### 20.3.5 Emulation Mode Chip Selects (CSE[1:0])

The emulation mode chip select (CSE[1:0]) output signals provide information for development support. In single-chip mode and master mode, these pins are configured as digital I/O (PE4 and PE3) by default.

### 20.3.6 Transfer Code (TC[2:0])

The transfer code (TC[2:0]) output signals indicate the data transfer code for the current bus cycle. See [20.9.4 Transfer Code \(TC\[2:0\]\)](#) for codes. In single-chip mode and master mode, these pins are configured as digital I/O (PE2, PE1, PE0) by default.

### 20.3.7 Read/Write (R/W)

The read/write (R/W) output signal indicates the direction of the data transfer on the bus. A logic 1 indicates a read from a slave device and a logic 0 indicates a write to a slave device.

### 20.3.8 Address Bus (A[22:0])

The address bus (A[22:0]) output signals provide the address for the current bus transfer.

### 20.3.9 Enable Byte ( $\overline{EB}$ [3:0])

The enable byte ( $\overline{EB}$ [3:0]) output signals indicate which byte of data is valid during external cycles.

### 20.3.10 Chip Selects ( $\overline{CS}$ [3:0])

The chip select ( $\overline{CS}$ [3:0]) output signals select external devices for external bus transactions.

### 20.3.11 Output Enable ( $\overline{OE}$ )

The output enable ( $\overline{OE}$ ) signal indicates when an external device can drive data during external read cycles.

### 20.3.12 Transfer Size (TSIZ[1:0])

TSIZ[1:0] provides an indication of the M•CORE transfer size. See [Table 20-2](#). This function is enabled by default in master mode and emulation mode, and disabled by default in single-chip mode. Selection of this function is through the Chip Configuration Register (see [4.7.3.1 Chip Configuration Register](#)). When this feature is disabled, these pins act as pins INT7 and INT6 of the EPORT module.

### 20.3.13 Processor Status (PSTAT[3:0])

PSTAT[3:0] provides an indication of the M•CORE processor status. See [Table 20-6](#) for status indication codes. This function is enabled by default in emulation mode, and disabled by default in master mode and single-chip mode. Selection of this function is through the Chip Configuration Register. When this feature is disabled, these pins act as pins INT5, INT4, INT3, and INT2 of the EPORT module.

## 20.4 Memory Map and Registers

The EBI is not memory-mapped and has no software-accessible registers.

## 20.5 Operand Transfer

The possible operand accesses for the internal M•CORE bus are:

- Byte
- Aligned upper half-word
- Aligned lower half-word
- Aligned word

No misaligned transfers are supported. The EBI controls the byte, half-word, or word operand transfers between the M•CORE bus and a 16-bit or 32-bit port. “Port” refers to the width of the data path that an external device uses during a data transfer. Each port is assigned to

particular bits of the data bus. A 16-bit port is assigned to pins D[31:16] and a 32-bit port is assigned to pins D[31:0].

**Table 20-2** shows each possible transfer size, alignment, and port width. The data bytes shown in the table represent external data pins. This data is multiplexed and driven to the external data bus as shown. The bytes labeled with a dash are not required; the M•CORE will ignore them on read transfers, and drive them with undefined data on write transfers.

**Table 20-2. Data Transfer Cases**

Transfer Size	Port Width	External Pins				Data Bus Transfer					
		TSIZ1	TSIZ0	A1	A0						
Byte	16	0	1	0	0	D[31:24]	—	—	—		
	32					D[31:24]	—	—	—		
	16			0	1	0	1	—	D[23:16]	—	—
	32							—	D[23:16]	—	—
	16			1	0	1	0	—	—	D[31:24]	—
	32							—	—	D[15:8]	—
	16			1	1	1	1	—	—	—	D[23:16]
	32							—	—	—	D[7:0]
Half-word	16	1	0	0	0	D[31:24]	D[23:16]	—	—		
	32					D[31:24]	D[23:16]	—	—		
	16			1	0	1	0	—	—	D[31:24]	D[23:16]
	32							—	—	D[15:8]	D[7:0]
Word	16 <sup>(1)</sup>	0	0	0	0	D[31:24]	D[23:16]	—	—		
		1		1	0	—	—	D[31:24]	D[23:16]		
	32	0		0	0	D[31:24]	D[23:16]	D[15:8]	D[7:0]		

1. The EBI runs two cycles for word accesses to 16-bit ports. The table shows the data placement for both bus cycles.

In the case of a word (32-bit) access to a 16-bit port, the EBI runs two external bus cycles to complete the transfer. During the first external bus cycle, the A[1:0] pins are driven low, and the TSIZ[1:0] pins are driven to indicate word size. During the second cycle, A1 is driven high to

increment the external address by two bytes, A0 is still driven low, and the TSIZ[1:0] pins are driven to indicate half-word size.

During any word-size transfer, the EBI always drives the A[1:0] pins low during a word transfer (except on the second cycle of a word to half-word port transfer in which A1 is incremented).

## 20.6 Enable Byte Pins ( $\overline{EB[3:0]}$ )

The enable byte pins ( $\overline{EB[3:0]}$ ) are configurable as byte enables for read and write cycles, or as write enables for write cycles only. The default function is byte enable unless there is an active chip-select match with the WE bit set. In all external cycles when one or more EB pins are asserted, the encoding corresponds to the external data pins to be used for the transfer as outlined in [Table 20-3](#).

**Table 20-3.  $\overline{EB[3:0]}$  Assertion Encoding**

$\overline{EB}$ Pin	External Data Pins
EB0	D[31:24]
EB1	D[23:16]
EB2	D[15:8]
EB3	D[7:0]

## 20.7 Bus Master Cycles

In this subsection, each EBI bus cycle type is defined in terms of actions associated with a succession of internal states.

Read or write operations may require multiple bus cycles to complete based on the operand size and target port size. Refer to [20.5 Operand Transfer](#) for more information. In the discussion that follows, it is assumed that only a single bus cycle is required for a transfer.

In the waveform diagrams ([Figure 20-3](#) through [Figure 20-6](#)), data transfers are related to clock cycles, independent of the clock frequency. The external bus states are also noted.

### 20.7.1 Read Cycles

During a read cycle, the EBI receives data from an external memory or peripheral device. During external read cycles, the  $\overline{OE}$  pin is asserted regardless of operand size. See **Figure 20-1**. Also see **Figure 20-3** and **Figure 20-4** for read cycle timing diagrams with and without wait states.

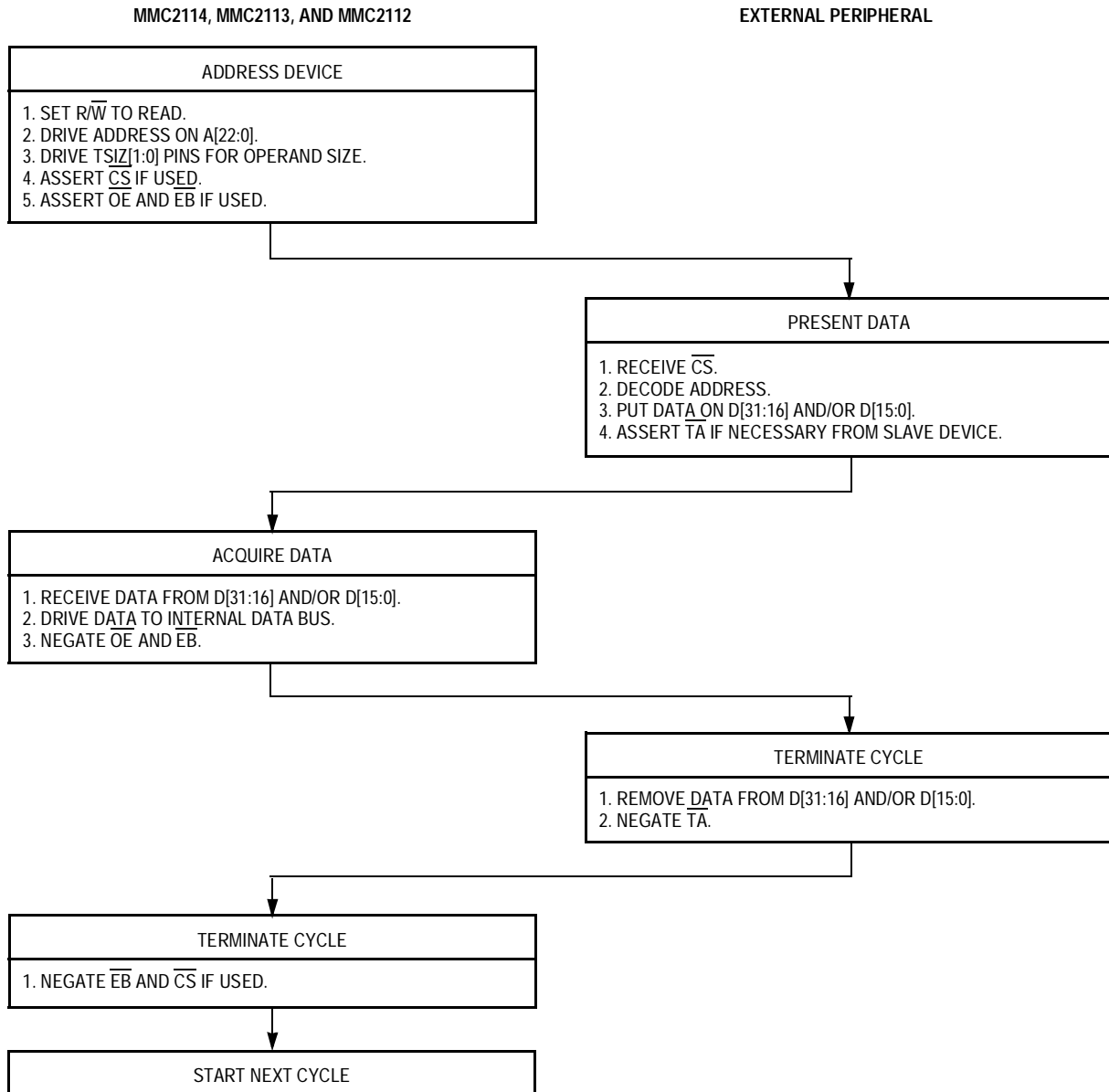

Figure 20-1. Read Cycle Flowchart

## External Bus Interface Module (EBI)

## 20.7.1.1 State 1 (X1)

The EBI drives the address bus.  $\overline{R/W}$  is driven high to indicate a read cycle. The TSIZ[1:0] pins are driven to indicate the number of bytes in the transfer. TC[2:0] pins are driven to indicate the type of access.  $\overline{CS}$  may be asserted to drive a device.

Later in state 1,  $\overline{OE}$  is asserted. If the  $\overline{EB}$  pins are not configured as write enables for this cycle, one or more  $\overline{EB}$  pins are also asserted, depending on the size and position of the data to be transferred.

If either the external  $\overline{TA}$  pin or internal chip-select transfer acknowledge signal is asserted before the end of state 1, the EBI proceeds to state 2.

## 20.7.1.2 Optional Wait States (X2W)

Wait states are inserted until the slave asserts the  $\overline{TA}$  pin or the internal chip-select transfer acknowledge signal is asserted. Wait states are counted in full clocks.

## 20.7.1.3 State 2 (X2)

One-half clock later in state 2, the selected device puts its information on D[31:16] and/or D[15:0]. One or both half-words of the external data bus are driven to the internal data bus.

The address bus,  $\overline{R/W}$ ,  $\overline{CS}$ ,  $\overline{OE}$ ,  $\overline{EB}$ , TC, and TSIZ pins remain valid through state 2 to allow for static memory operation and signal skew.

The slave device asserts data until it detects the negation of  $\overline{OE}$ , after which it must remove its data within one-half state. Note that the data bus may not become free until state 1.



### 20.7.2 Write Cycles

On a write cycle, the EBI transfers data to an external memory or peripheral device. See [Figure 20-2](#). Also see [Figure 20-3](#) and [Figure 20-4](#) for write cycle timing diagrams with and without wait states.

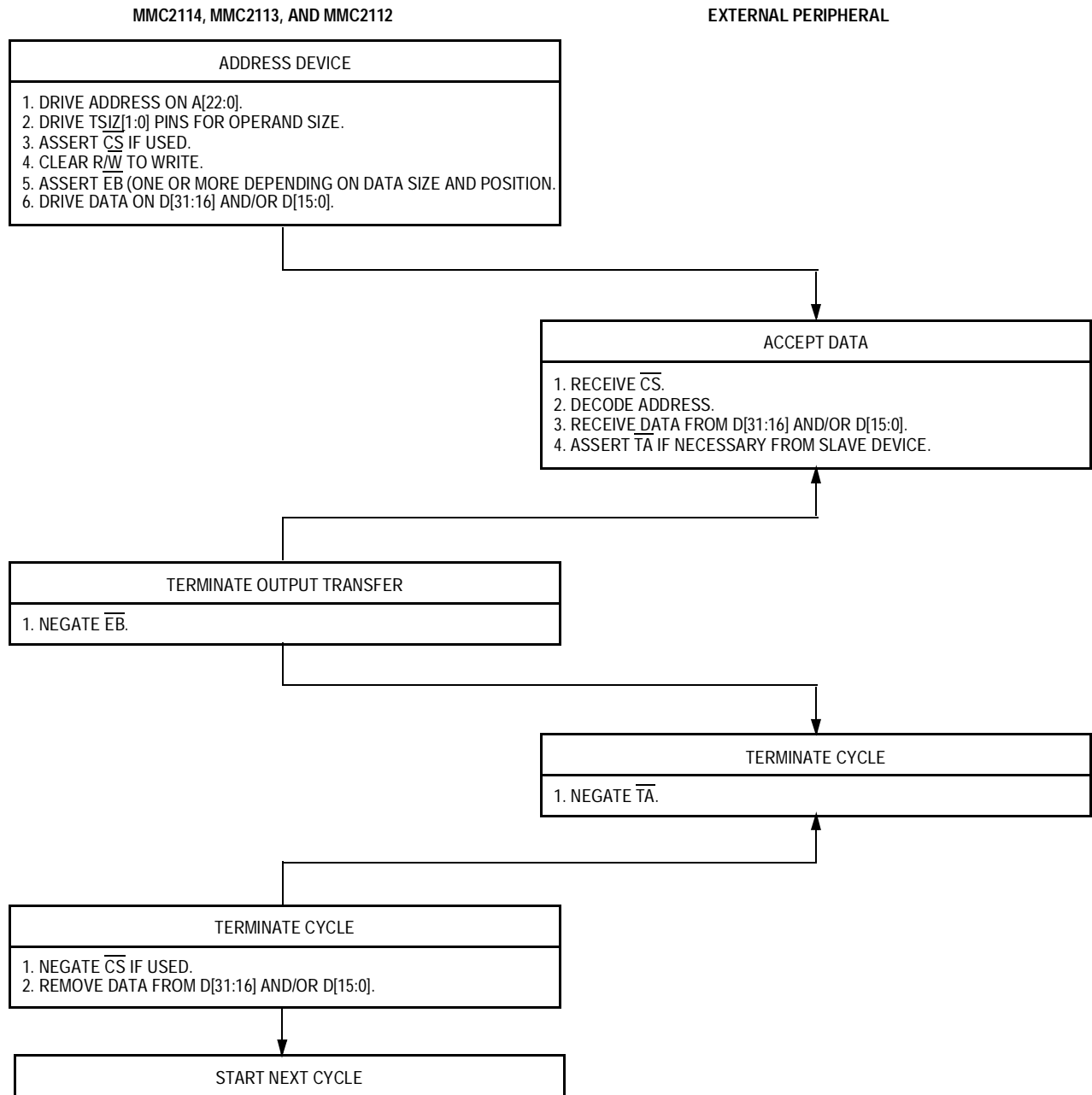

Figure 20-2. Write Cycle Flowchart

## External Bus Interface Module (EBI)

## 20.7.2.1 State 1 (X1)

The EBI drives the address bus. The TSIZ[1:0] pins are driven to indicate the number of bytes in the transfer. TC[2:0] pins are driven to indicate the type of access.  $\overline{CS}$  may be asserted to drive a device.  $\overline{OE}$  is negated.

Later in state 1,  $R/\overline{W}$  is driven low indicating a write cycle. One or more  $\overline{EB}$  pins are asserted, depending on the size and position of the data to be transferred.

If either the external  $\overline{TA}$  pin or internal chip-select transfer acknowledge signal is asserted before the end of state 1, the EBI proceeds to state 2.

## 20.7.2.2 Optional Wait States (X2W)

Wait states are inserted until the slave asserts the  $\overline{TA}$  pin or the internal chip-select transfer acknowledge signal is asserted. The EBI drives its data onto data bus lines D[31:16] and/or D[15:0] on the first optional wait state. Wait states are counted in full clocks.

## 20.7.2.3 State 2 (X2)

If the data was not already driven during optional wait states, the EBI drives its data onto D[31:16] and/or D[15:0] in state 2.

$\overline{EB}$  is negated by the end of state 2. The address bus, data bus,  $R/\overline{W}$ ,  $\overline{CS}$ , TC[2:0], and TSIZ[1:0] pins remain valid through state 2 to allow for static memory operation and signal skew.

**Figure 20-3** and **Figure 20-4** illustrate external bus master cycles with and without wait states and show M•CORE bus activity.

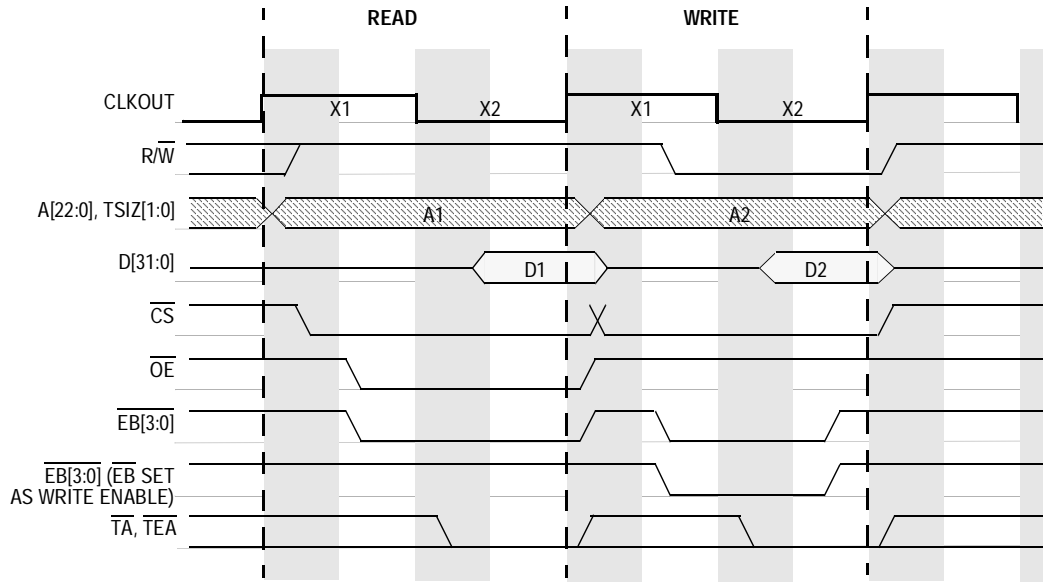

Figure 20-3. Master Mode — 1-Clock Read and Write Cycle

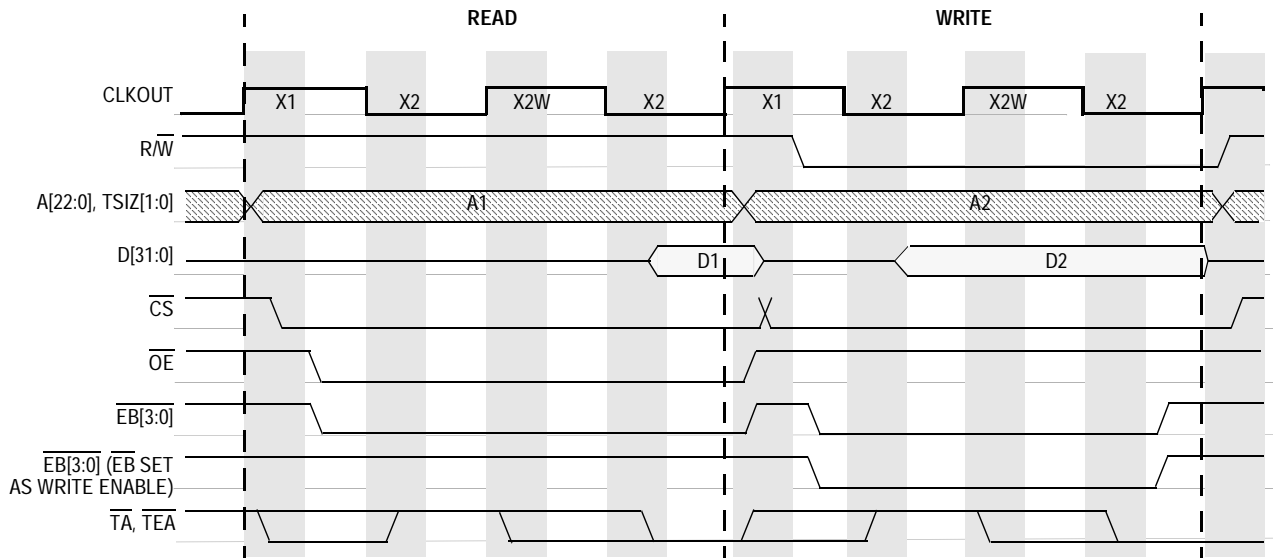

Figure 20-4. Master Mode — 2-Clock Read and Write Cycle

## 20.8 Bus Exception Operation

### 20.8.1 Transfer Error Termination

Normal bus cycle termination requires the assertion of the  $\overline{\text{TA}}$  pin or the internal transfer acknowledge signal. Minimal bus exception support is provided by transfer error cycle termination. For transfer error cycle termination, the external  $\overline{\text{TEA}}$  pin or the internal transfer error acknowledge signal is asserted. Transfer error cycle termination takes precedence over normal cycle termination, provided  $\overline{\text{TEA}}$  assertion meets its timing constraints.

The internal bus monitor will assert the internal transfer error acknowledge signal when  $\overline{\text{TA}}$  response time is too long, based upon the BMT[1:0] settings in the Chip Configuration Registers (CCR). See [4.7.3.1 Chip Configuration Register](#).

### 20.8.2 Transfer Abort Termination

External bus cycles which are aborted by the M•CORE, still have the address,  $\overline{\text{R/W}}$ , TC[2:0], TSIZ[1:0],  $\overline{\text{CS}}$  (if used),  $\overline{\text{OE}}$  (reads only), and SHS (if used) driven to the external pins.

## 20.9 Emulation Support

### 20.9.1 Emulation Chip-Selects (CSE[1:0])

While in emulation mode or master mode, special emulator chip-selects (CSE[1:0]) are driven externally to allow internal/external accesses to be tracked by external hardware. See [Table 20-4](#).

In emulation mode, all port registers are mapped externally. CSE[1:0] = 10 whenever any emulated port registers are addressed. The lower bits of the address bus indicate the register accessed within the block.

Accesses to the address space which contains the registers for the internal modules (except ports) are indicated by CSE[1:0] = 11.

Internal accesses, other than to the specific module control registers, are indicated by CSE[1:0] = 01. It should be noted that at higher frequencies writes to external memories emulating the internal memories may require one clock for read accesses and two clocks for write accesses.

**Table 20-4. Emulation Mode Chip-Select Summary<sup>(1)</sup>**

CSE1	CSE0	Indication in Emulation Mode
1	1	Internal access to any register space (excluding ports) Reset state (0x00c1_0000:0x00ff_ffff)
1	0	Internal access to ports register space (0x00c0_0000:0x00c0_ffff)
0	1	Internal access not covered by CSE encoding = 11, 10 (0x0000_0000:0x00bf_ffff; 0x0100_0000:0x07ff_ffff)
0	0	External access (0x8000_0000 to 0xffff_ffff)

1. CSE[1:0] is valid only for the duration of valid bus cycles or reset. Undefined otherwise.

### 20.9.2 Internal Data Transfer Display (Show Cycles)

Internal data transfers normally occur without showing the internal data bus activity on the external data bus. For debugging purposes, however, it may be desirable to have internal cycle data appear on the external bus. These external bus cycles are referred to as show cycles and are distinguished from normal external cycles by the fact that  $\overline{OE}$  and  $\overline{EB}[3:0]$  remain negated.

Regardless of whether show cycles are enabled, the EBI drives the address bus, TC[2:0], TSIZ[1:0] and  $\overline{R/W}$  signals, indicating the internal cycle activity. When show cycles are disabled, D[31:0] remains in a high impedance state. When show cycles are enabled,  $\overline{OE}$  and  $\overline{EB}[3:0]$  remain negated while the internal data is presented on D[31:0] on the first clock tick after the termination of the internal cycle.

Show cycles are always enabled in emulation mode. In master mode, show cycles are disabled coming out of reset and must be enabled by writing to the SHEN bit in the Chip Configuration Register (CCR).

External Bus Interface Module (EBI)

**NOTE:** The PEPA and PCDDPA bits in the ports must also be set to 1 to obtain full visibility. The waveforms shown in [Figure 20-5](#) describe show cycles.

20.9.3 Show Strobe ( $\overline{\text{SHS}}$ )

The show strobe ( $\overline{\text{SHS}}$ ) pin provides an indication to an external device (emulator or logic analyzer) when to latch address, TC[2:0], TSIZ[1:0],  $\overline{\text{R}/\overline{\text{W}}}$ , CSE, PSTAT, and data from the external pins. In master and emulation modes, show cycle strobe (SHS) is enabled coming out of reset. In master mode this default functionality can be overridden to make the pin function as digital I/O.

For any external cycle or show cycle, the  $\overline{\text{SHS}}$  pin is driven low to indicate valid address, TC, TSIZ,  $\overline{\text{R}/\overline{\text{W}}}$ , CSE, and PSTAT are present at the pins, and driven back high to indicate valid data. The  $\overline{\text{SHS}}$  pin is driven low and back high only once per external bus cycle. See [Figure 20-5](#) and [Figure 20-6](#).

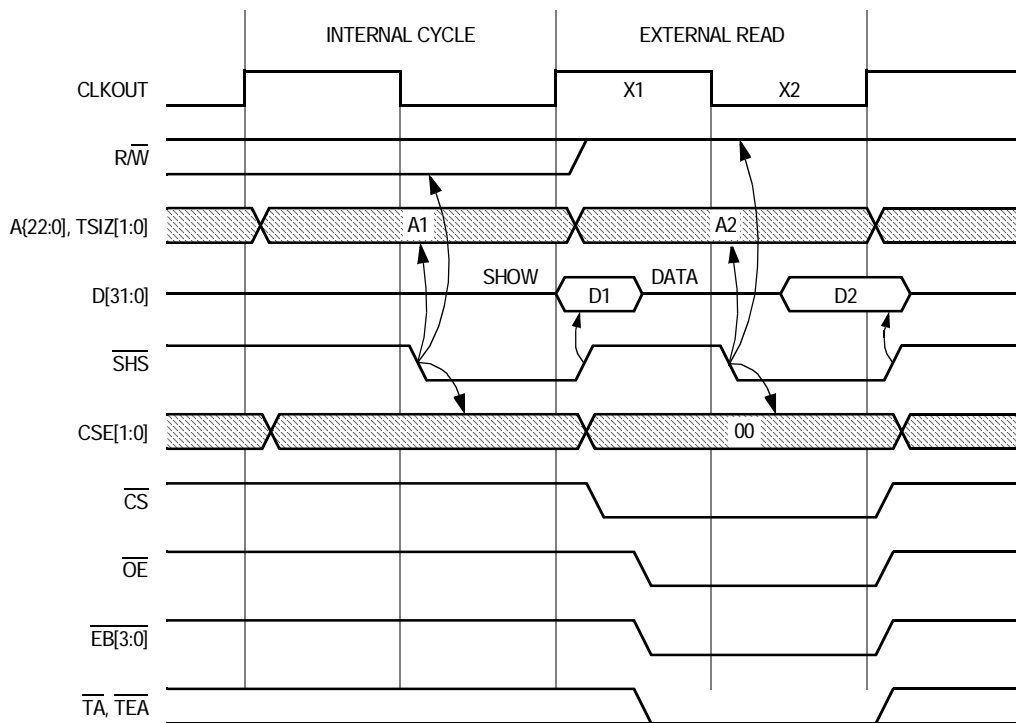

Figure 20-5. Internal (Show) Cycle Followed by External 1-Clock Read

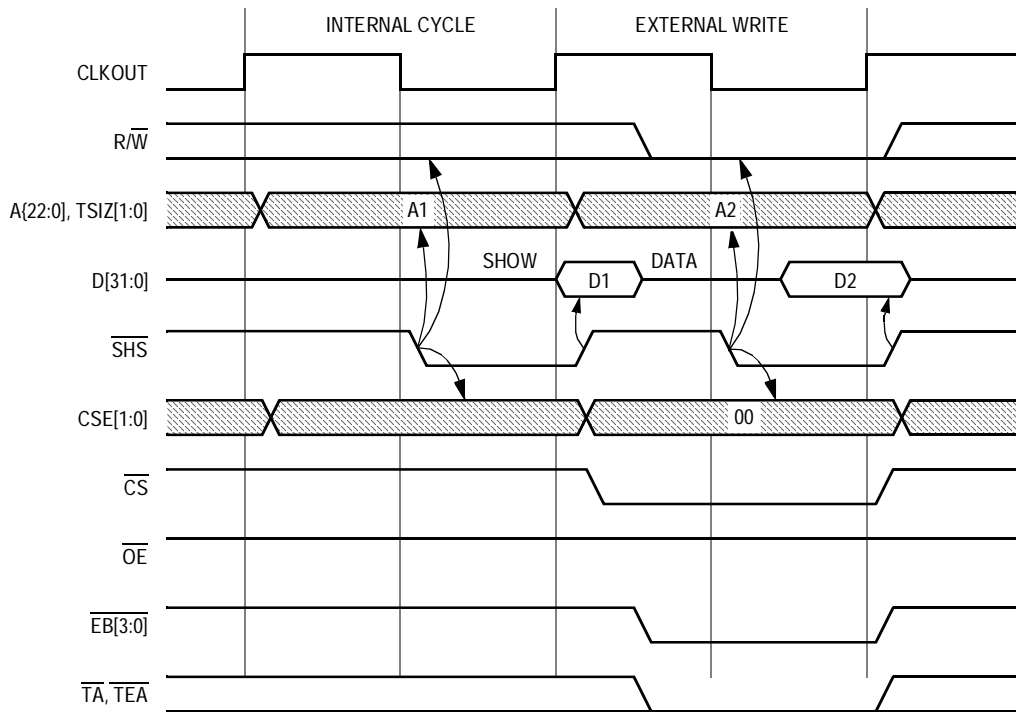

Figure 20-6. Internal (Show) Cycle Followed by External 1-Clock Write

### 20.9.4 Transfer Code (TC[2:0])

These signals are outputs from a master and inputs to a slave device. They are enabled by default in emulation mode and can be enabled in other modes by setting PEPA[2:0] of Port E Pin Assignment Register (PEPAR). See [12.4.2.6 Port E Pin Assignment Register](#). These signals identify the processor state (supervisor or user) and the address space of the current bus cycle. The space and state are defined in [Table 20-5](#).

### 20.9.5 Processor Status (PSTAT)

These signals are outputs from the CPU and may be applied to external pins (INT[5:2]). They are enabled by default in emulation mode and can be enabled in other modes by setting PSTEN of CCR. See [4.7.3.1 Chip Configuration Register](#). The PSTAT pins indicate the internal state and events occurring within the core, and may be monitored by a debug block to condition events, and/or may be reflected off-chip as well. [Table 20-6](#) shows the definitions of the processor status encoding.

**Table 20-5. Transfer Code Definitions**

TC[2]	TC[1]	TC[0]	Transfer Type
0	0	0	User data access <sup>(1)</sup>
0	0	1	Reserved
0	1	0	User instruction access <sup>(2)</sup>
0	1	1	User change of flow instruction access <sup>(3)</sup>
1	0	0	Supervisor data access <sup>(1)</sup>
1	0	1	Supervisor exception vector access
1	1	0	Supervisor instruction access <sup>(2)</sup>
1	1	1	Supervisor change of flow instruction access <sup>(3)</sup>

1. Except lrw accesses.
2. Except change of flow related instruction accesses, includes lrw accesses.
3. Change of flow related instruction access for taken branches, jumps, and loopt instructions (includes table accesses for jmp, jsr).

**Table 20-6. Processor Status Encoding**

PST[3]	PST[2]	PST[1]	PST[0]	Internal Processor State
0	0	0	0	Execution stalled
0	0	0	1	Execution stalled
0	0	1	0	Execute exception
0	0	1	1	Reserved
0	1	0	0	Processor in STOP, WAIT, or DOZE state
0	1	0	1	Execution stalled
0	1	1	0	Processor in debug mode
0	1	1	1	Reserved
1	0	0	0	Launch instruction <sup>(1)</sup>
1	0	0	1	Launch ldm, stm, ldq, or stq
1	0	1	0	Launch hardware accelerator instruction
1	0	1	1	Launch lrw
1	1	0	0	Launch change of program flow instruction
1	1	0	1	Launch rte or rfi
1	1	1	0	Reserved
1	1	1	1	Launch jmp or jsr

1. Except ldm, stm, ldq, stq, hardware accelerator, lrw, change of flow, rte, or rfi instructions.



## 20.10 Bus Monitor

The bus monitor can be set to detect excessively long bus access termination response times. Whenever an undecoded address is accessed or a peripheral is inoperative, the access is not terminated and the bus is potentially locked up while it waits for the required response.

The bus monitor monitors the cycle termination response time during a bus cycle. If the cycle termination response time exceeds a programmed count, the bus monitor asserts an internal bus error.

The bus monitor monitors the cycle termination response time (in system clock cycles) by using a programmable maximum allowable response period. There are four selectable response time periods for the bus monitor, selectable among 8, 16, 32, and 64 system clock cycles. The periods are selectable with the BMT[1:0] field in the chip configuration module CCR (see [4.7.3.1 Chip Configuration Register](#)). The programmability of the timeout allows for varying external peripheral response times. The monitor is cleared and restarted on all bus accesses. If the cycle is not terminated within the selected response time, a timeout occurs and the bus monitor terminates the bus cycle.

The bus monitor can be configured with the BME bit in the chip configuration module CCR to monitor only internal bus accesses or both internal and external bus accesses. Also, the bus monitor can be disabled during debug mode for both internal and external accesses.

Two external bus cycles are required for a single 32-bit access to a 16-bit port. If the bus monitor is enabled to monitor external accesses, then the bus monitor views the 32-bit access as two separate external bus cycles and not as one internal bus cycle.

## 20.11 Interrupts

The EBI does not generate interrupt requests.



## Section 21. Chip Select Module

### 21.1 Contents

21.2	Introduction .....	547
21.3	Features .....	548
21.4	Block Diagram .....	549
21.5	Signals .....	550
21.6	Memory Map and Registers .....	550
21.6.1	Memory Map .....	550
21.6.2	Registers .....	551
21.7	Functional Description .....	556
21.8	Interrupts .....	557

### 21.2 Introduction

The chip select module provides chip enable signals for external memory and peripheral devices. The chip selects can also be programmed to terminate bus cycles. Up to four asynchronous chip select signals are available.

## 21.3 Features

Features of the chip select module include:

- Reduced system complexity — No external glue logic required for typical systems if chip selects are used.
- Four programmable asynchronous active-low chip selects ( $\overline{\text{CS}}[3:0]$ ) — Chip selects can be independently programmed with various features.
- Control for external boot device —  $\overline{\text{CS}}0$  can be enabled at reset to select an external boot device.
- Fixed base addresses with 8-Mbyte block sizes
- Support for emulating internal memory space — When the EMINT bit is set in the Chip Configuration Register (CCR),  $\overline{\text{CS}}1$  matches only addresses in the internal memory space.
- Support for 16-bit and 32-bit external devices — The external port size can be programmed to be 16 or 32 bits.
- Programmable write protection — Each chip select address range can be designated for read access only.
- Programmable access protection — Each chip select address range can be designated for supervisor access only.
- Write-enable selection — The enable byte pins ( $\overline{\text{EB}}[3:0]$ ) can be configured as byte enables (assert on both external read and write accesses) or write enables (only assert on external write accesses).
- Bus cycle termination — This option allows the chip select logic to terminate the bus cycle.
- Programmable wait states — To interface with various devices, up to seven wait states can be programmed before the access is terminated.
- Programmable extra wait state for write accesses — One wait state can be added to write accesses to allow writing to memories that require additional data setup time.

## 21.4 Block Diagram

**Figure 21-1** shows a programmable asynchronous chip select. All asynchronous chip selects have the same structure. All signals used to generate chip select signals are taken from the internal bus. Each chip select has a chip select control register to individually program the chip select characteristics.

All the chip selects share the same cycle termination generator. The active chip select for a particular bus cycle determines the number of wait states produced by the cycle termination generator before the cycle is terminated.

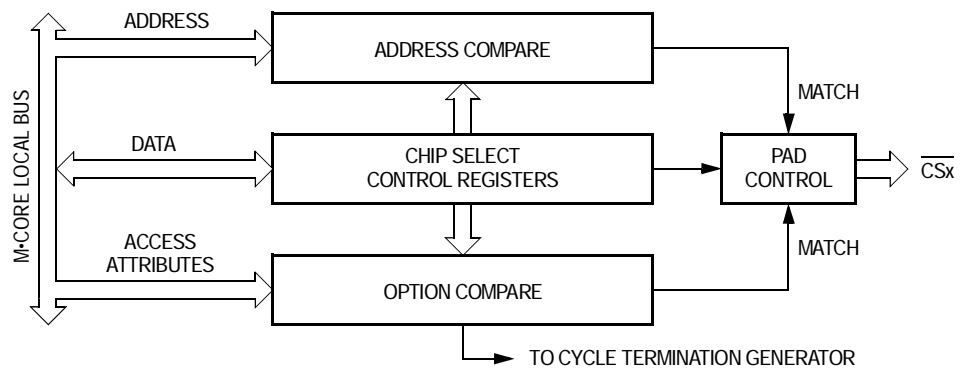

**Figure 21-1. Chip Select Block Diagram**

## 21.5 Signals

**Table 21-1** provides an overview of the signals described here.

**Table 21-1. Signal Properties**

Name	Function	Reset State	Pullup
$\overline{CS0}$	Chip select 0 pin	1	Active
$\overline{CS1}$	Chip select 1 pin	1	Active
$\overline{CS2}$	Chip select 2 pin	1	Active
$\overline{CS3}$	Chip select 3 pin	1	Active

$\overline{CS}[3:0]$  are chip-select outputs.  $\overline{CS}[3:0]$  are available for general-purpose input/output (I/O) when not configured for chip select operation.

## 21.6 Memory Map and Registers

**Table 21-2** shows the chip select memory map. The registers are described in **21.6.2 Registers**.

### 21.6.1 Memory Map

**Table 21-2. Chip Select Memory Map**

Address	Bits 31–16	Bits 15–0	Access <sup>(1), (2)</sup>
0x00c2_0000	CSCR0 — Chip Select Control Register 0	CSCR1 — Chip Select Control Register 1	S
0x00c2_0004	CSCR2 — Chip Select Control Register 2	CSCR3 — Chip Select Control Register 3	S

1. User mode accesses to supervisor-only address locations have no effect and result in a cycle termination transfer error.
2. S = CPU supervisor mode access only.

### 21.6.2 Registers

The chip programming model consists of four Chip Select Control Registers (CSCR0–CSCR3), one for each chip select ( $\overline{CS}[3:0]$ ). CSCR0–CSCR3 are read/write always and define the conditions for asserting the chip select signals.

All the chip select control registers are the same except for the reset states of the CSEN and PS bits in CSCR0 and the CSEN bit in CSCR1. This allows  $\overline{CS0}$  to be enabled at reset with either a 16-bit or 32-bit port size for selecting an external boot device and allows  $\overline{CS1}$  to be used to emulate internal memory.

Address: 0x00c2\_0000 and 0x00c2\_0001

	Bit 15	14	13	12	11	10	9	Bit 8
Read:	SO	RO	PS	WWS	WE	WS2	WS1	WS0
Write:								
Reset:	0	0	See note	1	1	1	1	1
	Bit 7	6	5	4	3	2	1	Bit 0
Read:	0	0	0	0	0	0	TAEN	CSEN
Write:								
Reset:	0	0	0	0	0	0	1	See note

= Writes have no effect and the access terminates without a transfer error exception.

Note: Reset state determined during reset configuration.

**Figure 21-2. Chip Select Control Register 0 (CSCR0)**

Chip Select Module

Address: 0x00c2\_0002 and 0x00c2\_0003

	Bit 15	14	13	12	11	10	9	Bit 8
Read:	SO	RO	PS	WWS	WE	WS2	WS1	WS0
Write:								
Reset:	0	0	1	1	1	1	1	1
	Bit 7	6	5	4	3	2	1	Bit 0
Read:	0	0	0	0	0	0	TAEN	CSEN
Write:								
Reset:	0	0	0	0	0	0	1	See note

= Writes have no effect and the access terminates without a transfer error exception.

Note: Reset state determined during reset configuration.

**Figure 21-3. Chip Select Control Register 1 (CSCR1)**

Address: 0x00c2\_0004 and 0x00c2\_0005

	Bit 15	14	13	12	11	10	9	Bit 8
Read:	SO	RO	PS	WWS	WE	WS2	WS1	WS0
Write:								
Reset:	0	0	1	1	1	1	1	1
	Bit 7	6	5	4	3	2	1	Bit 0
Read:	0	0	0	0	0	0	TAEN	CSEN
Write:								
Reset:	0	0	0	0	0	0	1	0

= Writes have no effect and the access terminates without a transfer error exception.

**Figure 21-4. Chip Select Control Register 2 (CSCR2)**



Address: 0x00c2\_00006 and 0x00c2\_0007

	Bit 15	14	13	12	11	10	9	Bit 8
Read:	SO	RO	PS	WWS	WE	WS2	WS1	WS0
Write:								
Reset:	0	0	1	1	1	1	1	1
	Bit 7	6	5	4	3	2	1	Bit 0
Read:	0	0	0	0	0	0	TAEN	CSEN
Write:								
Reset:	0	0	0	0	0	0	1	0

= Writes have no effect and the access terminates without a transfer error exception.

**Figure 21-5. Chip Select Control Register 3 (CSCR3)**

**SO — Supervisor-Only Bit**

The SO bit restricts user mode access to the address range defined by the corresponding chip select. If the SO bit is 1, only supervisor mode access is permitted. If the SO bit is 0, both supervisor and user level accesses are permitted.

When an access is made to a memory space assigned to the chip select, the chip select logic compares the SO bit with bit 2 of the internal transfer code, which indicates whether the access is at the supervisor or user level. If the chip select logic detects a protection violation, the access is ignored.

- 1 = Only supervisor mode accesses allowed; user mode accesses ignored by chip select logic
- 0 = Supervisor and user mode accesses allowed

**RO — Read-Only Bit**

The RO bit restricts write accesses to the address range defined by the corresponding chip select. If the RO bit is 1, only read access is permitted. If the RO bit is 0, both read and write accesses are permitted.

When an access is made to a memory space assigned to the chip select, the chip select logic compares the RO bit with the internal

read/write signal, which indicates whether the access is a read (read/write = 1) or a write (read/write = 0). If the chip select logic detects a violation (RO = 1 with read/write = 0), the access is ignored.

1 = Only read accesses allowed; write accesses ignored by the chip select logic

0 = Read and write accesses allowed

#### PS — Port Size Bit

The PS bit defines the width of the external data port supported by the chip select as either 16-bit or 32-bit. When a chip select is programmed as a 16-bit port, the external device must be connected to D[31:16]. For 32-bit accesses to 16-bit ports, the external memory interface initiates two bus cycles and multiplexes data as needed to complete the data transfer.

1 = 32 bit port

0 = 16 bit port

#### WWS — Write Wait State Bit

The WWS bit determines if an additional wait state is required for write cycles. WWS does not affect read cycles.

1 = One additional wait state added for write cycles

0 = No additional wait state added for write cycles

#### WE — Write Enable Bit

The WE bit defines when the enable byte output pins ( $\overline{EB}[3:0]$ ) are asserted. When WE is 0,  $\overline{EB}[3:0]$  are configured as byte enables and assert for both external read and external write accesses. When WE is 1,  $\overline{EB}[3:0]$  are configured as write enables and assert only for external write accesses.

1 =  $\overline{EB}[3:0]$  configured as write enables

0 =  $\overline{EB}[3:0]$  configured as byte enables

**NOTE:** *The WE bit has no effect on the  $\overline{EB}[3:0]$  pin function if the chip select is not active. If the chip select is not active, the  $\overline{EB}[3:0]$  pin function is byte enable by default.*

**WS[2:0] — Wait States Field**

The WS field determines the number of wait states for the chip select logic to insert before asserting the internal cycle termination signal. One wait state is equal to one system clock cycle. If WS is configured for zero wait states, then the internal cycle termination signal is asserted in the clock cycle following the start of the cycle access, resulting in one-clock transfers. A WS configured for one wait state means that the internal cycle termination signal is asserted two clock cycles after the start of the cycle access.

Since the internal cycle termination signal is asserted internally after the programmed number of wait states, software can adjust the bus timing to accommodate the access speed of the external device. With up to seven possible wait states, even slow devices can be interfaced with the MCU.

**Table 21-3. Chip Select Wait States Encoding**

WS[2:0]	Number of Wait States			
	WWS = 0		WWS = 1	
	Read Access	Write Access	Read Access	Write Access
000	0	0	0	1
001	1	1	1	2
010	2	2	2	3
011	3	3	3	4
100	4	4	4	5
101	5	5	5	6
110	6	6	6	7
111	7	7	7	8

**TAEN — Transfer Acknowledge Enable Bit**

The TAEN bit determines whether the internal cycle termination signal is asserted by the chip select logic when accesses occur to the address range defined by the corresponding chip select. When TAEN is 0, an external device is responsible for asserting the external  $\overline{TA}$  pin to terminate the bus access. When TAEN is 1, the chip select logic asserts the internal cycle termination signal after a time determined by the programmed number of wait states. When TAEN is 1, external

logic can still terminate the access before the internal cycle termination signal is asserted by asserting the external  $\overline{TA}$  pin.

1 = Internal cycle termination signal asserted by chip select logic

0 = Internal cycle termination signal asserted by external logic

#### CSEN — Chip Select Enable Bit

The CSEN bit enables the chip select logic. When the chip select function is disabled, the  $\overline{CSx}$  signal is negated high.

1 = Chip select function enabled

0 = Chip select function disabled

## 21.7 Functional Description

Each chip select can provide a chip enable signal for an external device and assert the internal bus cycle termination signal.

Setting the CSEN bit in CSCR enables the chip select to provide an external chip enable signal.

Setting both the CSEN and TAEN bits in CSCR enables the chip select to generate the internal bus cycle termination signal.

Both the chip select pin assertion and the bus cycle termination function depend on an initial address/option match for activation. During the matching process, the fixed base address of each chip select is compared to the corresponding address for the bus cycle to determine whether an address match has occurred. This match is further qualified by comparing the internal read/write indication and access type with the programmed values in CSCR of each chip select. When the address and option information match the current cycle, the chip select is activated. If no chip select matches the bus cycle information for the current access, the chip select logic does not respond in any way.

Only one chip select can be active for a given bus cycle. The configuration of the active chip select, determined by the wait state (WS/WWS) field, the port size (PS) field, and the write enable (WE) field, is used for the access.

**NOTE:** *WWS and WS are valid only if the TAEN bit is 1 for the active chip select.*

When no chip select pin is available, the active chip select can still terminate the bus cycle. If both the CSEN and TAEN bits are 1 and the address/options match the chip select configuration, then the chip select logic asserts the internal termination signal; the bus cycle terminates after the programmed number of wait states. If the external  $\overline{TA}$  or  $\overline{TEA}$  pin is asserted before the chip select logic asserts the internal cycle termination signal, then the bus cycle is terminated early.

If internal address bit 31 is 0, then the access is internal. If internal address bit 31 is 1, then the access is external.

**NOTE:** *Chip select logic does not decode internal address bits A[30:25].*

**Table 21-4. Chip Select Address Range Encoding**

Chip Select	Block Size	Address Range	Address Bits Compared (A[31:23]) <sup>(1)</sup>
$\overline{CS0}$	8 MB	0x8000_0000–0x807f_ffff	1xxx_xxx0_0
$\overline{CS1}$	8 MB	0x8080_0000–0x80ff_ffff	1xxx_xxx0_1 <sup>(2)</sup>
$\overline{CS2}$	8 MB	0x8100_0000–0x817f_ffff	1xxx_xxx1_0
$\overline{CS3}$	8 MB	0x8180_0000–0x81ff_ffff	1xxx_xxx1_1

1. The chip selects do not decode A[30:25]. Thus, the total 32-Mbyte block size is repeated/mirrored in external memory space.
2. If the EMINT bit in the chip configuration module CCR is set, then  $\overline{CS1}$  matches only internal accesses to the 8-MB block starting at address 0 to support emulation of internal memory. Thus, A[31:23] match 0xxx\_xxx0\_0.

## 21.8 Interrupts

The chip select module does not generate interrupt requests.



## Section 22. JTAG Test Access Port and OnCE

### 22.1 Contents

22.2	Introduction . . . . .	561
22.3	Top-Level Test Access Port (TAP) . . . . .	563
22.3.1	Test Clock (TCLK) . . . . .	564
22.3.2	Test Mode Select (TMS) . . . . .	564
22.3.3	Test Data Input (TDI) . . . . .	564
22.3.4	Test Data Output (TDO) . . . . .	564
22.3.5	Test Reset (TRST) . . . . .	564
22.3.6	Debug Event (DE) . . . . .	564
22.4	Top-Level TAP Controller . . . . .	566
22.5	Instruction Shift Register . . . . .	567
22.5.1	EXTEST Instruction . . . . .	567
22.5.2	IDCODE Instruction . . . . .	568
22.5.3	SAMPLE/PRELOAD Instruction . . . . .	569
22.5.4	ENABLE_MCU_ONCE Instruction . . . . .	569
22.5.5	HIGHZ Instruction . . . . .	570
22.5.6	CLAMP Instruction . . . . .	570
22.5.7	BYPASS Instruction . . . . .	570
22.6	IDCODE Register . . . . .	571
22.7	Bypass Register . . . . .	572
22.8	Boundary Scan Register . . . . .	572
22.9	Restrictions . . . . .	572
22.10	Non-Scan Chain Operation . . . . .	573
22.11	Boundary Scan . . . . .	573
22.12	Low-Level TAP (OnCE) Module . . . . .	579
22.13	Signal Descriptions . . . . .	581
22.13.1	Debug Serial Input (TDI) . . . . .	581
22.13.2	Debug Serial Clock (TCLK) . . . . .	581
22.13.3	Debug Serial Output (TDO) . . . . .	581

22.13.4	Debug Mode Select (TMS)	582
22.13.5	Test Reset ( $\overline{\text{TRST}}$ )	582
22.13.6	Debug Event ( $\overline{\text{DE}}$ )	582
22.14	Functional Description	582
22.14.1	Operation	583
22.14.2	OnCE Controller and Serial Interface	584
22.14.3	OnCE Interface Signals	585
22.14.3.1	Internal Debug Request Input ( $\overline{\text{IDR}}$ )	585
22.14.3.2	CPU Debug Request ( $\overline{\text{DBGREQ}}$ )	586
22.14.3.3	CPU Debug Acknowledge ( $\overline{\text{DBGACK}}$ )	586
22.14.3.4	CPU Breakpoint Request ( $\overline{\text{BRKRQ}}$ )	586
22.14.3.5	CPU Address, Attributes (ADDR, ATTR)	587
22.14.3.6	CPU Status (PSTAT)	587
22.14.3.7	OnCE Debug Output ( $\overline{\text{DEBUG}}$ )	587
22.14.4	OnCE Controller Registers	587
22.14.4.1	OnCE Command Register	588
22.14.4.2	OnCE Control Register	590
22.14.4.3	OnCE Status Register	594
22.14.5	OnCE Decoder (ODEC)	596
22.14.6	Memory Breakpoint Logic	596
22.14.6.1	Memory Address Latch (MAL)	597
22.14.6.2	Breakpoint Address Base Registers	597
22.14.7	Breakpoint Address Mask Registers	597
22.14.7.1	Breakpoint Address Comparators	598
22.14.7.2	Memory Breakpoint Counters	598
22.14.8	OnCE Trace Logic	598
22.14.8.1	OnCE Trace Counter	599
22.14.8.2	Trace Operation	600
22.14.9	Methods of Entering Debug Mode	600
22.14.9.1	Debug Request During $\overline{\text{RESET}}$	600
22.14.9.2	Debug Request During Normal Activity	601
22.14.9.3	Debug Request During Stop, Doze, or Wait Mode	601
22.14.9.4	Software Request During Normal Activity	601
22.14.10	Enabling OnCE Trace Mode	601
22.14.11	Enabling OnCE Memory Breakpoints	602
22.14.12	Pipeline Information and Write-Back Bus Register	602
22.14.12.1	Program Counter Register	603
22.14.12.2	Instruction Register	603



22.14.12.3 Control State Register . . . . . 603  
 22.14.12.4 Writeback Bus Register . . . . . 605  
 22.14.12.5 Processor Status Register . . . . . 605  
 22.14.13 Instruction Address FIFO Buffer (PC FIFO) . . . . . 606  
 22.14.14 Reserved Test Control Registers . . . . . 607  
 22.14.15 Serial Protocol . . . . . 607  
 22.14.16 OnCE Commands . . . . . 608  
 22.14.17 Target Site Debug System Requirements . . . . . 608  
 22.14.18 Interface Connector for JTAG/OnCE Serial Port . . . . . 608

## 22.2 Introduction

The MMC2114, MMC2113, and MMC2112 have two JTAG (Joint Test Action Group) TAP (test access port) controllers:

1. A top-level controller that allows access to the Boundary Scan (external pins) Register, IDCODE Register, and Bypass Register
2. A low-level OnCE (on-chip emulation) controller that allows access to the central processor unit (CPU) and debugger-related registers

At power-up, only the top-level TAP controller will be visible. If desired, a user can then enable the low-level OnCE controller which will in turn disable the top-level TAP controller. The top-level TAP controller will remain disabled until either power is removed and reapplied or until the test reset signal,  $\overline{\text{TRST}}$ , is asserted (logic 0).

The OnCE TAP controller can be enabled in either of two ways:

1. With the top-level TAP controller in its test-logic-reset state:
  - a. Deassert  $\overline{\text{TRST}}$ , test reset (logic1)
  - b. Assert  $\overline{\text{DE}}$ , the debug event (logic 0) for two TCLK, test clock, cycles
2. Shift the ENABLE\_MCU\_ONCE instruction, 0x3, into the top-level TAP controller's Instruction Register (IR) and pass through the TAP controller state update-IR.

Refer to [Figure 22-1](#).

JTAG Test Access Port and OnCE

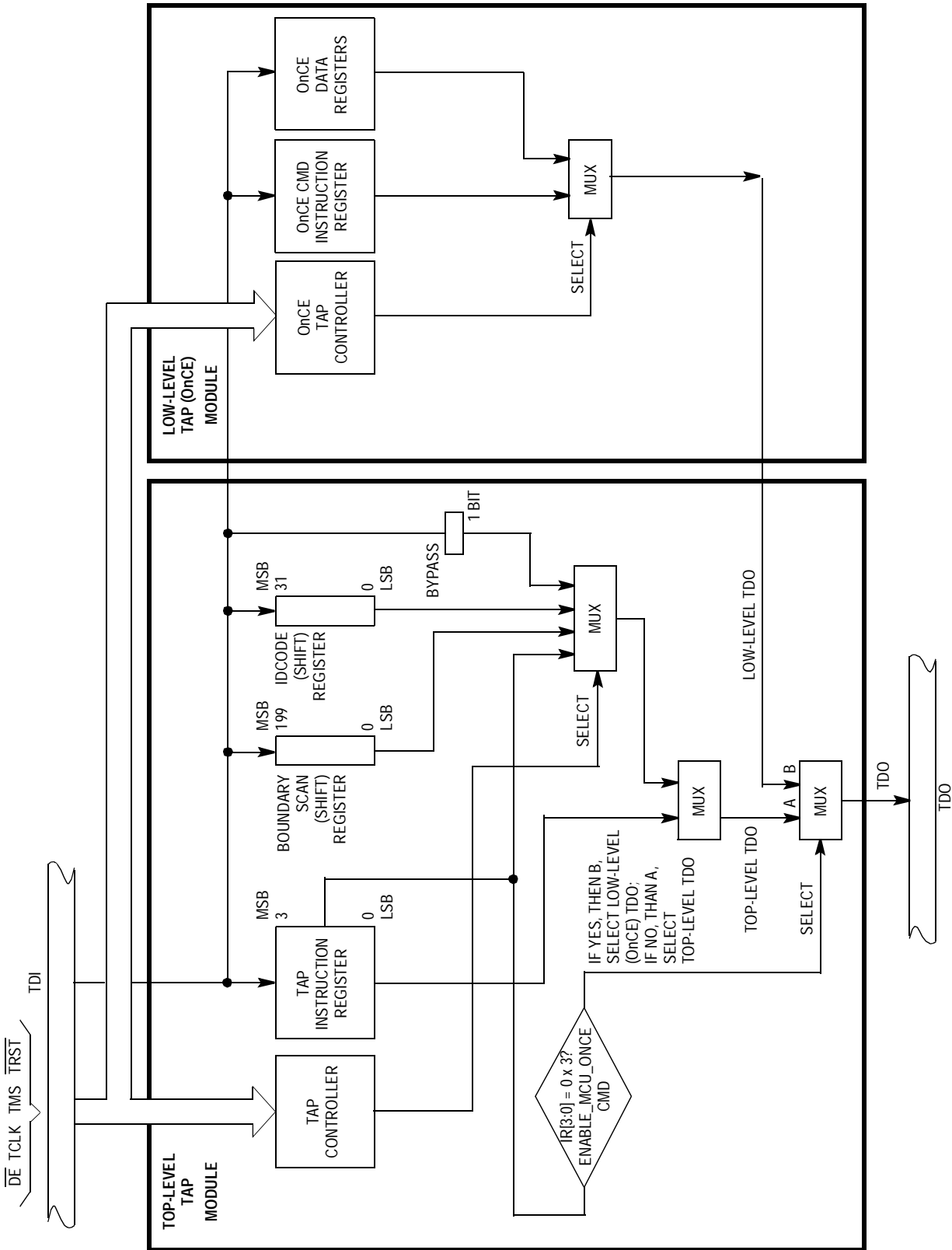

Figure 22-1. Top-Level Tap Module and Low-Level (OnCE) TAP Module

## 22.3 Top-Level Test Access Port (TAP)

These devices provide a dedicated user-accessible test access port (TAP) that is fully compatible with the *IEEE 1149.1 Standard Test Access Port and Boundary-Scan Architecture*. Problems associated with testing high-density circuit boards have led to development of this proposed standard under the sponsorship of the Test Technology Committee of IEEE and the Joint Test Action Group (JTAG). The implementation supports circuit-board test strategies based on this standard.

The top-level TAP consists of five dedicated signal pins, a 16-state TAP controller, an instruction register, and three data registers, a boundary scan register for monitoring and controlling the device's external pins, a device identification register, and a 1-bit bypass (do nothing) register.

The top-level TAP provides the ability to:

1. Perform boundary scan (external pin) drive and monitor operations to test circuitry external to these devices
2. Disable the output pins
3. Read the IDCODE Device Identification Register

**CAUTION:** *Certain precautions must be observed to ensure that the top-level TAP module does not interfere with non-test operation. See [22.10 Non-Scan Chain Operation](#) for details.*

The top-level TAP module includes a TAP controller, a 4-bit instruction register, and three test data registers (a 1-bit bypass register, a 200-bit boundary scan register, and a 32-bit IDCODE register). The top-level tap controller and the low-level (OnCE) TAP controller share the external signals described here.

### 22.3.1 Test Clock (TCLK)

TCLK is a test clock input to synchronize the test logic. TCLK is independent of the processor clock. It includes an internal pullup resistor.

### 22.3.2 Test Mode Select (TMS)

TMS is a test mode select input (with an internal pullup resistor) that is sampled on the rising edge of TCLK to sequence the TAP controller's state machine.

### 22.3.3 Test Data Input (TDI)

TDI is a serial test data input (with an internal pullup resistor) that is sampled on the rising edge of TCLK.

### 22.3.4 Test Data Output (TDO)

TDO is a three-state test data output that is actively driven in the shift-IR and shift-DR controller states. TDO changes on the falling edge of TCLK.

### 22.3.5 Test Reset ( $\overline{\text{TRST}}$ )

$\overline{\text{TRST}}$  is an active low asynchronous reset with an internal pullup resistor that forces the TAP controller into the test-logic-reset state.

### 22.3.6 Debug Event ( $\overline{\text{DE}}$ )

This is a bidirectional, active-low signal.

As an output, this signal will be asserted for three system clocks, synchronous to the rising CLKOUT edge, to acknowledge that the CPU has entered debug mode as a result of a debug request or a breakpoint condition.

As an input, this signal provides multiple functions such as:

- The main function is a means of entering debug mode from an external command controller. This signal, when asserted, causes the CPU to finish the current instruction being executed, save the instruction pipeline information, enter debug mode, and wait for commands to be entered from the serial debug input line. This input must be asserted for at least three system clocks, sampled with the rising CLKOUT edge. This function is ignored during reset. While the processor is in debug mode, this signal is still sampled but has no effect until debug mode is exited.
- Another input function is to enable OnCE. This is an alternate method to the ENABLE\_MCU\_ONCE JTAG command to enable the OnCE logic to be accessible via the JTAG interface. This input signal must be asserted low (while in the test-logic-reset state with POR/TRST not asserted) for at least two TCLK rising edges. Once enabled, the OnCE will remain enabled until the next POR or TRST resets.
- Another input function is as a wake-up event from a low-power mode of operation. Asynchronously asserting this signal will cause the clock controller to restart. This signal must be held asserted until the M•CORE receives three valid rising edges on the system clock. Then the processor will exit the low-power mode and go into debug mode.

**NOTE:** *If used to enter debug mode,  $\overline{DE}$  must be negated before the processor exits debug mode to prevent a still low signal from being unintentionally recognized as another debug request. Also, asserting this signal to enter debug mode may prevent external logic from seeing the processor output acknowledgment since the external pullup may not be able to pull the signal negated before the handshake is asserted. Finally, if using this signal to enable OnCE outside of reset it may be seen as a request to enter debug mode.*

### 22.4 Top-Level TAP Controller

The top-level TAP controller is responsible for interpreting the sequence of logical values on the TMS signal. It is a synchronous state machine that controls the operation of the JTAG logic. The machine's states are shown in **Figure 22-2**. The value shown adjacent to each arc represents the value of the TMS signal sampled on the rising edge of the TCLK signal.

The top-level TAP controller can be asynchronously reset to the test-logic-reset state by asserting  $\overline{\text{TRST}}$ , test reset. As **Figure 22-2** shows, holding TMS high (to logic 1) while clocking TCLK through at least five rising edges will also cause the state machine to enter its test-logic-reset state.

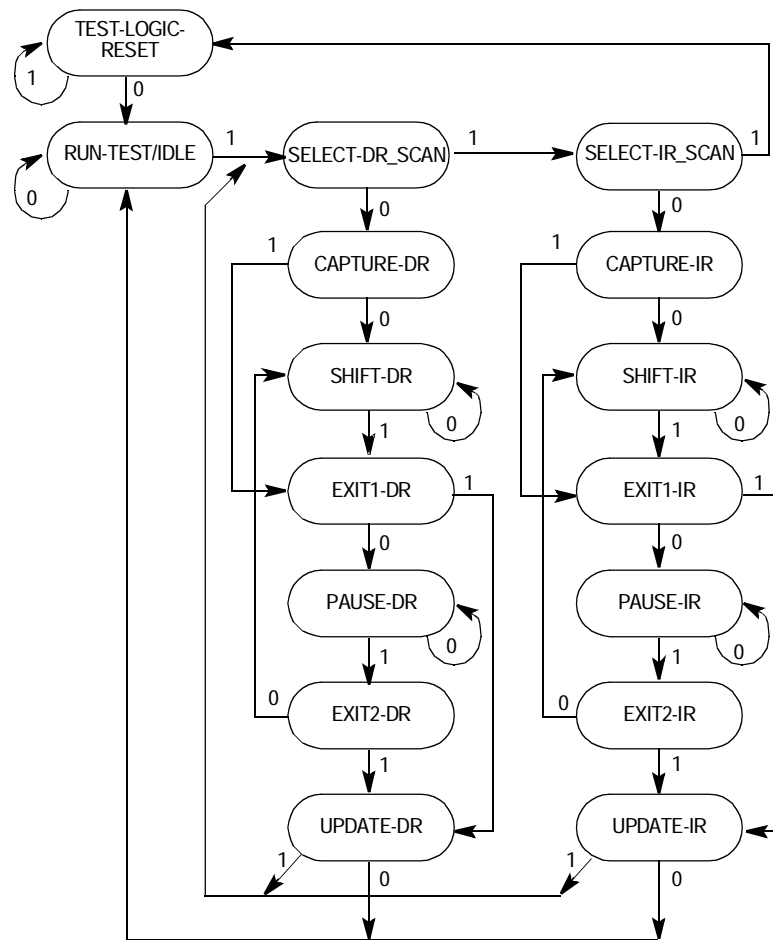

**Figure 22-2. Top-Level TAP Controller State Machine**

## 22.5 Instruction Shift Register

The top-level TAP module uses a 4-bit Instruction Shift Register with no parity. This register transfers its value to a parallel hold register and applies an instruction on the falling edge of TCLK when the TAP state machine is in the update-IR state. To load the instructions into the shift portion of the register, place the serial data on the TDI pin prior to each rising edge of TCLK. The MSB of the instruction shift register is the bit closest to the TDI pin and the LSB is the bit closest to the TDO pin.

**Table 22-1** lists the instructions supported along with their opcodes, IR3–IR0. The last three instructions in the table are reserved for manufacturing purposes only.

Unused opcodes are currently decoded to perform the BYPASS operation, but Motorola reserves the right to change their decodings in the future.

### 22.5.1 EXTEST Instruction

The external test instruction (EXTEST) selects the Boundary Scan Register. The EXTEST instruction forces all output pins and bidirectional pins configured as outputs to the preloaded fixed values (with the SAMPLE/PRELOAD instruction) and held in the boundary-scan update registers. The EXTEST instruction can also configure the direction of bidirectional pins and establish high-impedance states on some pins. EXTEST also asserts internal reset for the system logic to force a predictable internal state while performing external boundary scan operations.

**Table 22-1. JTAG Instructions**

Instruction	IR3–IR0	Instruction Summary
EXTEST	0000	Selects the Boundary Scan Register while applying fixed values to output pins and asserting functional reset
IDCODE	0001	Selects the IDCODE Register for shift
SAMPLE/PRELOAD	0010	Selects the Boundary Scan Register for shifting, sampling, and preloading without disturbing functional operation
ENABLE_MCU_ONCE	0011	Instruction to enable the M•CORE TAP controller
HIGHZ	1001	Selects the Bypass Register while three-stating all output pins and asserting functional reset
CLAMP	1100	Selects bypass while applying fixed values to output pins and asserting functional reset
BYPASS	1111	Selects the Bypass Register for data operations
Reserved	0100 0110 0101 <sup>(1)</sup> 1000	Instruction for chip manufacturing purposes only
Reserved	0111 1101–1110 1010–1011	Decoded to select the Bypass Register <sup>(2)</sup>

1. To exit this instruction, the  $\overline{\text{TRST}}$  pin must be asserted or power-on reset.

2. Motorola reserves the right to change the decoding of the unused opcodes in the future.

### 22.5.2 IDCODE Instruction

The IDCODE instruction selects the 32-bit IDCODE Register for connection as a shift path between the TDI pin and the TDO pin. This instruction allows interrogation of the device to determine its version number and other part identification data. The IDCODE Register has been implemented in accordance with the IEEE 1149.1 standard so that the least significant bit of the shift register stage is set to logic 1 on the rising edge of TCLK following entry into the capture-DR state. Therefore, the first bit to be shifted out after selecting the IDCODE Register is



always a logic 1. The remaining 31 bits are also set to fixed values on the rising edge of TCLK following entry into the capture-DR state.

IDCODE is the default instruction placed into the Instruction Shift Register when the top-level TAP resets. Thus, after a TAP reset, the IDCODE (data) register will be selected automatically.

### 22.5.3 SAMPLE/PRELOAD Instruction

The SAMPLE/PRELOAD instruction provides two separate functions.

First, it obtains a sample of the system data and control signals present at the input pins and just prior to the boundary scan cell at the output pins. This sampling occurs on the rising edge of TCLK in the capture-DR state when an instruction encoding of hex 2 is resident in the Instruction Shift Register. The user can observe this sampled data by shifting it through the Boundary Scan Register to the output TDO by using the shift-DR state. Both the data capture and the shift operation are transparent to system operation.

**NOTE:** *The user is responsible for providing some form of external synchronization to achieve meaningful results because there is no internal synchronization between TCLK and the system clock.*

The second function of the SAMPLE/PRELOAD instruction is to initialize the Boundary Scan Register update cells before selecting EXTEST or CLAMP. This is achieved by ignoring the data being shifted out of the TDO pin while shifting in initialization data. The update-DR state in conjunction with the falling edge of TCLK can then transfer this data to the update cells. This data will be applied to the external output pins when EXTEST or CLAMP instruction is applied.

### 22.5.4 ENABLE\_MCU\_ONCE Instruction

The ENABLE\_MCU\_ONCE is a public instruction to enable the M•CORE OnCE TAP controller. When the OnCE TAP controller is enabled, the top-level TAP controller connects the internal OnCE TDO to the pin TDO and remains in the run-test/idle state. It will remain in this

state until  $\overline{\text{TRST}}$  is asserted. While the OnCE TAP controller is enabled, the top-level JTAG remains transparent.

### 22.5.5 HIGHZ Instruction

The HIGHZ instruction is provided as a manufacturer's optional public instruction to prevent having to backdrive the output pins during circuit-board testing. When HIGHZ is invoked, all output drivers, including the 2-state drivers, are turned off (for example, high impedance). The instruction selects the Bypass Register. HIGHZ also asserts internal reset for the system logic to force a predictable internal state.

### 22.5.6 CLAMP Instruction

The CLAMP instruction selects the Bypass Register and asserts internal reset while simultaneously forcing all output pins and bidirectional pins configured as outputs to the fixed values that are preloaded and held in the Boundary Scan Update Register. This instruction enhances test efficiency by reducing the overall shift path to a single bit (the Bypass Register) while conducting an EXTEST type of instruction through the Boundary Scan Register.

### 22.5.7 BYPASS Instruction

The BYPASS instruction selects the single-bit Bypass Register, creating a single-bit shift register path from the TDI pin to the Bypass Register to the TDO pin. This instruction enhances test efficiency by reducing the overall shift path when a device other than the processor becomes the device under test on a board design with multiple chips on the overall IEEE 1149.1 standard defined boundary scan chain. The Bypass Register has been implemented in accordance with IEEE 1149.1 standard so that the shift register state is set to logic 0 on the rising edge of TCLK following entry into the capture-DR state. Therefore, the first bit to be shifted out after selecting the Bypass Register is always a logic 0 (to differentiate a part that supports an IDCODE register from a part that supports only the Bypass Register).

## 22.6 IDCODE Register

An IEEE 1149.1 standard compliant JTAG Identification Register (IDCODE) has been included on these devices.

Bit 31	30	29	28	27	26	25	Bit 24
0	0	0	0	0	1	0	1
Bit 23	22	21	20	19	18	17	Bit 16
1	1	0	0	0	0	0	1
Bit 15	14	13	12	11	10	9	Bit 8
0	1	1	1	0	0	0	0
Bit 7	6	5	4	3	2	1	Bit 0
0	0	0	1	1	1	0	1

**Figure 22-3. IDCODE Register Bit Specification**

Bits 31–28 — Version Number (Part Revision Number)

This is equivalent to the lower four bits of the PRN of the chip identification register located in the chip configuration module.

Bits 27–22 — Design Center

Indicates the Motorola Microcontroller Division

Bits 21–12 — Device Number (Part Identification Number)

Bits 19-12 are equivalent to the PIN of the chip identification register located in the chip configuration module.

Bits 11–1 — JEDEC ID

Indicates the reduced JEDEC ID for Motorola. JEDEC refers to the Joint Electron Device Engineering Council. Refer to JEDEC publication 106-A and chapter 11 of the IEEE 1149.1 standard for further information on this field.

Bit 0

Differentiates this register as the JTAG IDCODE Register (as opposed to the Bypass Register), according to the IEEE 1149.1 standard

## 22.7 Bypass Register

An IEEE 1149.1 standard-compliant Bypass Register is included. This register which creates a single bit shift register path from TDI to the Bypass Register to TDO when the BYPASS instruction is selected.

## 22.8 Boundary Scan Register

An IEEE 1149.1 standard-compliant Boundary Scan Register is included. The Boundary Scan Register is connected between TDI and TDO when the EXTEST or SAMPLE/PRELOAD instructions are selected. This register captures signal pin data on the input pins, forces fixed values on the output signal pins, and selects the direction and drive characteristics (a logic value or high impedance) of the bidirectional and three-state signal pins.

## 22.9 Restrictions

The test logic is implemented using static logic design, and TCLK can be stopped in either a high or low state without loss of data. The system logic, however, operates on a different system clock which is not synchronized to TCLK internally. Any mixed operation requiring the use of the IEEE 1149.1 standard test logic, in conjunction with system functional logic that uses both clocks, must have coordination and synchronization of these clocks done externally.

The control afforded by the output enable signals using the boundary scan register and the EXTEST instruction requires a compatible circuit-board test environment to avoid device-destructive configurations. The user must avoid situations in which the output drivers are enabled into actively driven networks.

These devices feature a low-power stop mode. The interaction of the scan chain interface with low-power stop mode is:

1. The TAP controller must be in the test-logic-reset state to either enter or remain in the low-power stop mode. Leaving the test-logic-reset state negates the ability to achieve low-power, but does not otherwise affect device functionality.
2. The TCLK input is not blocked in low-power stop mode. To consume minimal power, the TCLK input should be externally connected to  $V_{DD}$ .
3. The TMS, TDI,  $\overline{\text{TRST}}$  pins include on-chip pullup resistors. In low-power stop mode, these three pins should remain either unconnected or connected to  $V_{DD}$  to achieve minimal power consumption.

## 22.10 Non-Scan Chain Operation

Keeping the TAP controller in the test-logic-reset state will ensure that the scan chain test logic is kept transparent to the system logic. It is recommended that TMS, TDI, TCLK, and  $\overline{\text{TRST}}$  be pulled up.  $\overline{\text{TRST}}$  could be connected to ground. However, since there is a pullup on  $\overline{\text{TRST}}$ , some amount of current will result. JTAG will be initialized to the test-logic-reset state on power-up without  $\overline{\text{TRST}}$  asserted low due to the JTAG power-on-reset internal input. The low-level TAP module in the M•CORE also has the power-on-reset input.

## 22.11 Boundary Scan

The Boundary Scan Register contains 200 bits. This register can be connected between TDI and TDO when EXTEST or SAMPLE/PRELOAD instructions are selected. This register is used for capturing signal pin data on the input pins, forcing fixed values on the output signal pins, and selecting the direction and drive characteristics (a logic value or high impedance) of the bidirectional and three-state signal pins.

This IEEE 1149.1 standard-compliant Boundary Scan Register contains bits for bonded-out and non-bonded signals excluding JTAG signals, analog signals, power supplies, compliance enable pins, and clock signals. To maintain JTAG compliance, TEST should be held to logic 0 and DE should be held to logic 1. These non-scanned pins are shown in [Table 22-2](#).

**Table 22-2. List of Pins Not Scanned in JTAG Mode**

Pin Name	Pin Type
EXTAL	Clock/analog
XTAL	Clock/analog
V <sub>DDSYN</sub>	Supply
V <sub>SSSYN</sub>	Supply
PQA4–PQA3 and PQA1–PQA0	Analog
PQB3–PQB0	Analog
V <sub>RH</sub>	Supply
V <sub>RL</sub>	Supply
V <sub>DDA</sub>	Supply
V <sub>SSA</sub>	Supply
V <sub>DDH</sub>	Supply
$\overline{\text{TRST}}$	JTAG
TCLK	JTAG
TMS	JTAG
TDI	JTAG
TDO	JTAG
DE	JTAG compliance enable
TEST	JTAG compliance enable
V <sub>pp</sub>	Supply
V <sub>DDF</sub>	Supply
V <sub>SSF</sub>	Supply
V <sub>STBY</sub>	Supply
V <sub>DD</sub>	Supply
V <sub>SS</sub>	Supply

**Table 22-3** defines the Boundary Scan Register.

- The first column shows bit numbers assigned to each of the register's cells. The bit nearest to TDO (the first to be shifted in) is defined as bit 0.
- The second column lists the logical state bit for each pin alternately with the read/write direction control bit for that pin. The logic state bits are non-inverting with respect to their associated pins, so that a 1 logical state bit equates to a logical high voltage on its corresponding pin. A direction control bit value of 1 causes a pin's logical state to be expressed by its logic state bit, a read of a pin. A direction control bit value of 0 causes a pin's logical voltage to follow the state of its logical state bit, a write to a pin.

**Table 22-3. Boundary Scan Register Definition (Sheet 1 of 4)**  
(Note: Shaded regions indicate optional pins)

Bit	Logical State and Direction Control Bits for Each Pin	Bit	Logical State and Direction Control Bits for Each Pin
0	D31 logical state	17	A18 direction control
1	D31 direction control	18	A19 logical state
2	A12 logical state	19	A19 direction control
3	A12 direction control	20	$\overline{\text{RSTOUT}}$ logical state
4	A13 logical state	21	$\overline{\text{RSTOUT}}$ direction control
5	A13 direction control	22	A20 logical state
6	A14 logical state	23	A20 direction control
7	A14 direction control	24	$\overline{\text{RESET}}$ logical state
8	A15 logical state	25	$\overline{\text{RESET}}$ direction control
9	A15 direction control	26	A21 logical state
10	A16 logical state	27	A21 direction control
11	A16 direction control	28	A22 logical state
12	A17 logical state	29	A22 direction control
13	A17 direction control	30	$\overline{\text{TEA}}$ logical state
14	CLKOUT logical state	31	$\overline{\text{TEA}}$ direction control
15	CLKOUT direction control	32	$\overline{\text{EB0}}$ logical state
16	A18 logical state	33	$\overline{\text{EB0}}$ direction control

**Table 22-3. Boundary Scan Register Definition (Sheet 2 of 4)**  
 (Note: Shaded regions indicate optional pins)

Bit	Logical State and Direction Control Bits for Each Pin	Bit	Logical State and Direction Control Bits for Each Pin
34	$\overline{EB1}$ logical state	64	$\overline{CS2}$ logical state
35	$\overline{EB1}$ direction control	65	$\overline{CS2}$ direction control
36	$\overline{TA}$ logical state	66	$\overline{INT4}$ logical state
37	$\overline{TA}$ direction control	67	$\overline{INT4}$ direction control
38	$\overline{EB2}$ logical state	68	$\overline{CS3}$ logical state
39	$\overline{EB2}$ direction control	69	$\overline{CS3}$ direction control
40	$\overline{SHS}$ logical state	70	TC0 logical state
41	$\overline{SHS}$ direction control	71	TC0 direction control
42	$\overline{EB3}$ logical state	72	$\overline{INT3}$ logical state
43	$\overline{EB3}$ direction control	73	$\overline{INT3}$ direction control
44	$\overline{OE}$ logical state	74	TC1 logical state
45	$\overline{OE}$ direction control	75	TC1 direction control
46	$\overline{SS}$ logical state	76	$\overline{INT2}$ logical state
47	$\overline{SS}$ direction control	77	$\overline{INT2}$ direction control
48	SCK logical state	78	$\overline{INT1}$ logical state
49	SCK direction control	79	$\overline{INT1}$ direction control
50	MISO logical state	80	$\overline{INT0}$ logical state
51	MISO direction control	81	$\overline{INT0}$ direction control
52	MOSI logical state	82	RXD1 logical state
53	MOSI direction control	83	RXD1 direction control
54	$\overline{INT7}$ logical state	84	TXD1 logical state
55	$\overline{INT7}$ direction control	85	TXD1 direction control
56	$\overline{INT6}$ logical state	86	RXD2 logical state
57	$\overline{INT6}$ direction control	87	RXD2 direction control
58	$\overline{CS0}$ logical state	88	TC2 logical state
59	$\overline{CS0}$ direction control	89	TC2 direction control
60	$\overline{CS1}$ logical state	90	TXD2 logical state
61	$\overline{CS1}$ direction control	91	TXD2 direction control
62	$\overline{INT5}$ logical state	92	CSE0 logical state
63	$\overline{INT5}$ direction control	93	CSE0 direction control



**Table 22-3. Boundary Scan Register Definition (Sheet 3 of 4)**  
 (Note: Shaded regions indicate optional pins)

Bit	Logical State and Direction Control Bits for Each Pin	Bit	Logical State and Direction Control Bits for Each Pin
94	ICOC1_0 logical state	124	D2 logical state
95	ICOC1_0 direction control	125	D2 direction control
96	$\overline{\text{CSE1}}$ logical state	126	D3 logical state
97	$\overline{\text{CSE1}}$ direction control	127	D3 direction control
98	$\text{R}/\overline{\text{W}}$ logical state	128	D4 logical state
99	$\text{R}/\overline{\text{W}}$ direction control	129	D4 direction control
100	ICOC1_1 logical state	130	D5 logical state
101	ICOC1_1 direction control	131	D5 direction control
102	ICOC1_2 logical state	132	D6 logical state
103	ICOC1_2 direction control	133	D6 direction control
104	ICOC1_3 logical state	134	D7 logical state
105	ICOC1_3 direction control	135	D7 direction control
106	ICOC2_0 logical state	136	D8 logical state
107	ICOC2_0 direction control	137	D8 direction control
108	ICOC2_1 logical state	138	D9 logical state
109	ICOC2_1 direction control	139	D9 direction control
110	ICOC2_2 logical state	140	D10 logical state
111	ICOC2_2 direction control	141	D10 direction control
112	ICOC2_3 logical state	142	D11 logical state
113	ICOC2_3 direction control	143	D11 direction control
114	D0 logical state	144	D12 logical state
115	D0 direction control	145	D12 direction control
116	A0 logical state	146	D13 logical state
117	A0 direction control	147	D13 direction control
118	A1 logical state	148	D14 logical state
119	A1 direction control	149	D14 direction control
120	D1 logical state	150	A3 logical state
121	D1 direction control	151	A3 direction control
122	A2 logical state	152	A4 logical state
123	A2 direction control	153	A4 direction control

**Table 22-3. Boundary Scan Register Definition (Sheet 4 of 4)**  
 (Note: Shaded regions indicate optional pins)

Bit	Logical State and Direction Control Bits for Each Pin	Bit	Logical State and Direction Control Bits for Each Pin
154	D15 logical state	177	A8 direction control
155	D15 direction control	178	A9 logical state
156	A5 logical state	179	A9 direction control
157	A5 direction control	180	D23 logical state
158	D16 logical state	181	D23 direction control
159	D16 direction control	182	A10 logical state
160	A6 logical state	183	A10 direction control
161	A6 direction control	184	D24 logical state
162	A7 logical state	185	D24 direction control
163	A7 direction control	186	D25 logical state
164	D17 logical state	187	D25 direction control
165	D17 direction control	188	A11 logical state
166	D18 logical state	189	A11 direction control
167	D18 direction control	190	D26 logical state
168	D19 logical state	191	D16 direction control
169	D19 direction control	192	D27 logical state
170	D20 logical state	193	D27 direction control
171	D20 direction control	194	D28 logical state
172	D21 logical state	195	D28 direction control
173	D21 direction control	196	D29 logical state
174	D22 logical state	197	D29 direction control
175	D22 direction control	198	D30 logical state
176	A8 logical state	199	D30 direction control

## 22.12 Low-Level TAP (OnCE) Module

The low-level TAP (OnCE, on-chip emulation) circuitry provides a simple, inexpensive debugging interface that allows external access to the processor's internal registers and to memory/peripherals. OnCE capabilities are controlled through a serial interface, mapped onto a JTAG test access port (TAP) protocol.

Refer to [Figure 22-4](#) for a block diagram of the OnCE.

**NOTE:** *The interface to the OnCE controller and its resources is based on the TAP defined for JTAG in the IEEE 1149.1 standard.*

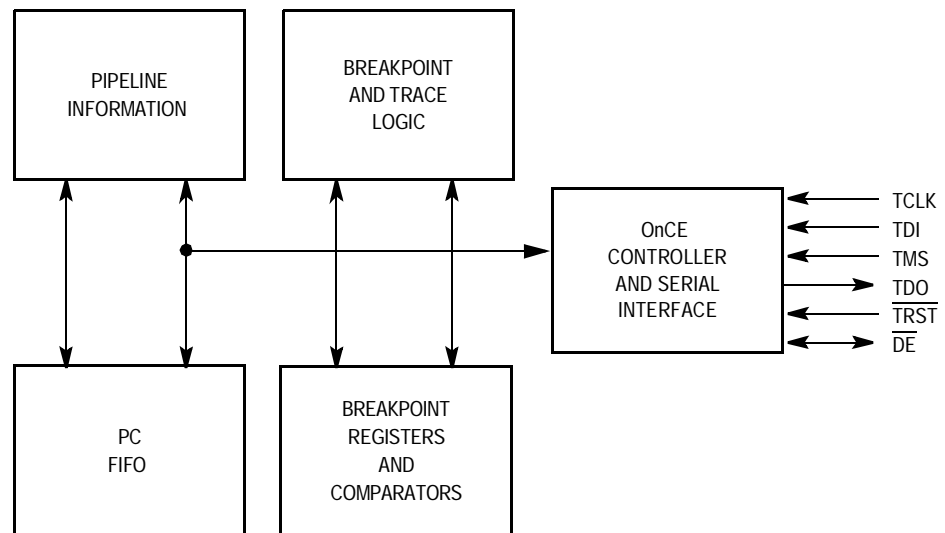

**Figure 22-4. OnCE Block Diagram**

[Figure 22-5](#) shows the OnCE (low-level TAP module) data registers.

JTAG Test Access Port and OnCE

DETAILED VIEW OF OnCE DATA REGISTERS BLOCK FOUND IN FIGURE 22-1

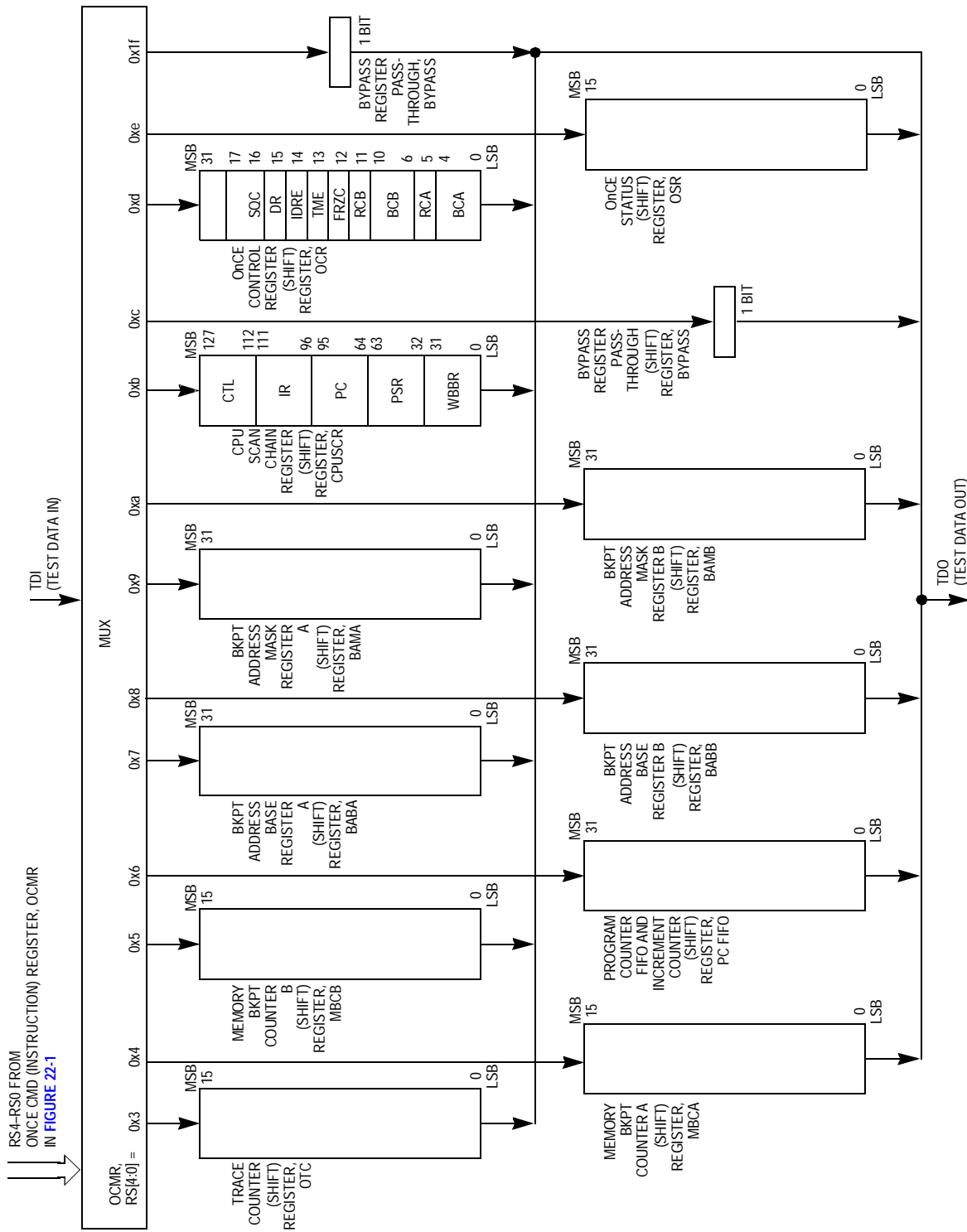

Figure 22-5. Low-Level (OnCE) Tap Module Data Registers (DRs)

## 22.13 Signal Descriptions

The OnCE pin interface is used to transfer OnCE instructions and data to the OnCE control block. Depending on the particular resource being accessed, the CPU may need to be placed in debug mode. For resources outside of the CPU block and contained in the OnCE block, the processor is not disturbed and may continue execution. If a processor resource is required, the OnCE controller may assert an internal debug request ( $\overline{DBGRQ}$ ) to the CPU. This causes the CPU to finish the instruction being executed, save the instruction pipeline information, enter debug mode, and wait for further commands.

**NOTE:** Asserting  $\overline{DBGRQ}$  causes the device to exit stop, doze, or wait mode and to enter debug mode.

### 22.13.1 Debug Serial Input (TDI)

Data and commands are provided to the OnCE controller through the TDI pin. Data is latched on the rising edge of the TCLK serial clock. Data is shifted into the OnCE serial port least significant bit (LSB) first.

### 22.13.2 Debug Serial Clock (TCLK)

The TCLK pin supplies the serial clock to the OnCE control block. The serial clock provides pulses required to shift data and commands into and out of the OnCE serial port. (Data is clocked into the OnCE on the rising edge and is clocked out of the OnCE serial port on the falling edge.) The debug serial clock frequency must be no greater than 50 percent of the processor clock frequency.

### 22.13.3 Debug Serial Output (TDO)

Serial data is read from the OnCE block through the TDO pin. Data is always shifted out the OnCE serial port LSB first. Data is clocked out of the OnCE serial port on the falling edge of TCLK. TDO is three-stateable and is actively driven in the shift-IR and shift-DR controller states. TDO changes on the falling edge of TCLK.

#### 22.13.4 Debug Mode Select (TMS)

The TMS input is used to cycle through states in the OnCE debug controller. Toggling the TMS pin while clocking with TCLK controls the transitions through the TAP state controller.

#### 22.13.5 Test Reset ( $\overline{\text{TRST}}$ )

The  $\overline{\text{TRST}}$  input is used to reset the OnCE controller externally by placing the OnCE control logic in a test logic reset state. OnCE operation is disabled in the reset controller and reserved states.

#### 22.13.6 Debug Event ( $\overline{\text{DE}}$ )

The  $\overline{\text{DE}}$  pin is a bidirectional open drain pin. As an input,  $\overline{\text{DE}}$  provides a fast means of entering debug mode from an external command controller. As an output, this pin provides a fast means of acknowledging debug mode entry to an external command controller.

The assertion of this pin by a command controller causes the CPU to finish the current instruction being executed, save the instruction pipeline information, enter debug mode, and wait for commands to be entered from the TDI line. If  $\overline{\text{DE}}$  was used to enter debug mode, then  $\overline{\text{DE}}$  must be negated after the OnCE responds with an acknowledgment and before sending the first OnCE command.

The assertion of this pin by the CPU acknowledges that it has entered debug mode and is waiting for commands to be entered from the TDI line.

### 22.14 Functional Description

The on-chip emulation (OnCE) circuitry provides a simple, inexpensive debugging interface that allows external access to the processor's internal registers and to memory/peripherals. OnCE capabilities are controlled through a serial interface, mapped onto a JTAG test access port (TAP) protocol. [Figure 22-6](#) shows the components of the OnCE circuitry.

**22.14.1 Operation**

An instruction is scanned into the OnCE module through the serial interface and then decoded. Data may then be scanned in and used to update a register or resource on a write to the resource, or data associated with a resource may be scanned out for a read of the resource.

For accesses to the CPU internal state, the OnCE controller requests the CPU to enter debug mode via the CPU  $\overline{\text{DBG\!RQ}}$  input. Once the CPU enters debug mode, as indicated by the OnCE Status Register (OSR), the processor state may be accessed through the CPU Scan Register.

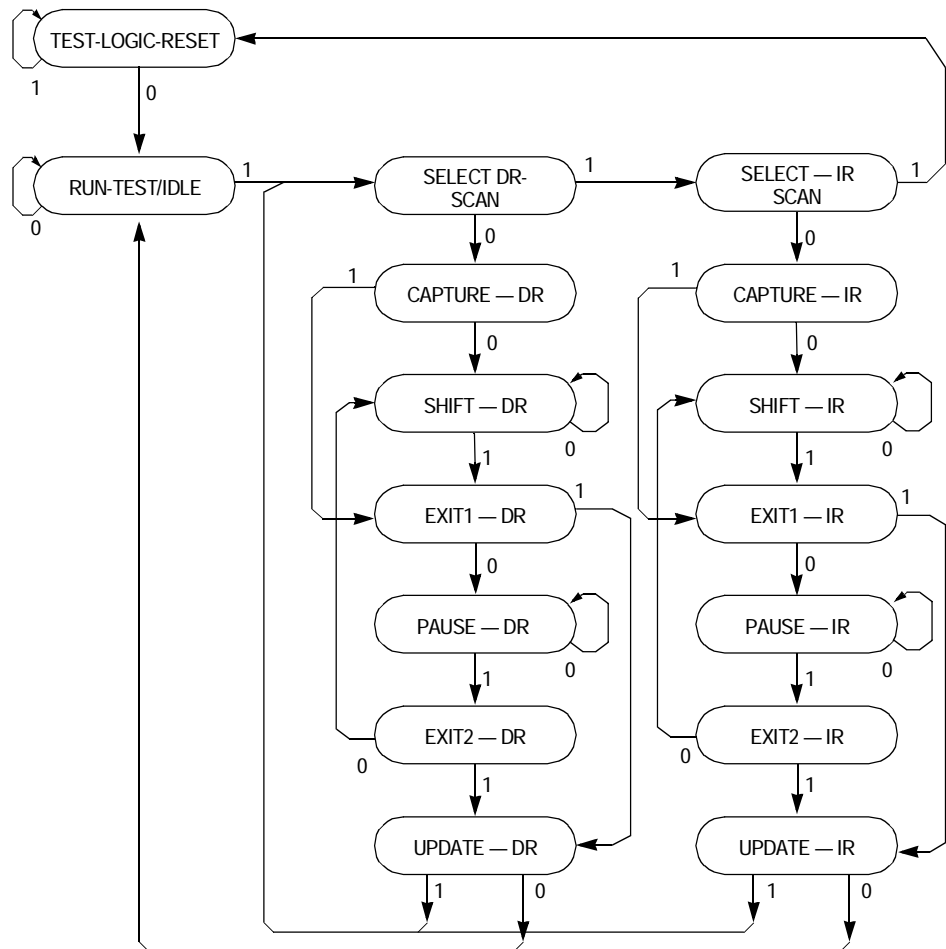

**Figure 22-6. OnCE Controller**

The OnCE controller is implemented as a 16-state finite state machine, with a one-to-one correspondence to the states defined for the JTAG TAP controller.

CPU registers and the contents of memory locations are accessed by scanning instructions and data into and out of the CPU scan chain. Required data is accessed by executing the scanned instructions. Memory locations may be read by scanning in a load instruction to the CPU that references the desired memory location, executing the load instruction, and then scanning out the result of the load. Other resources are accessed in a similar manner.

Resources contained in the OnCE module that do not require the CPU to be halted for access may be controlled while the CPU is executing and do not interfere with normal processor execution. Accesses to certain resources, such as the PC FIFO and the count registers, while not part of the CPU, may require the CPU to be stopped to allow access to avoid synchronization hazards. If it is known that the CPU clock is enabled and running no slower than the TCLK input, there is sufficient synchronization performed to allow reads but not writes of these specific resources. Debug firmware may ensure that it is safe to access these resources by reading the OSR to determine the state of the CPU prior to access. All other cases require the CPU to be in the debug state for deterministic operation.

### 22.14.2 OnCE Controller and Serial Interface

**Figure 22-7** is a block diagram of the OnCE controller and serial interface.

The OnCE Command Register (OCMR) acts as the Instruction Register (IR) for the TAP controller. All other OnCE resources are treated as data registers (DR) by the TAP controller. The Command Register is loaded by serially shifting in commands during the TAP controller shift-IR state, and is loaded during the update-IR state. The OCMR selects a OnCE resource to be accessed as a DR during the TAP controller capture-DR, shift-DR and update-DR states.



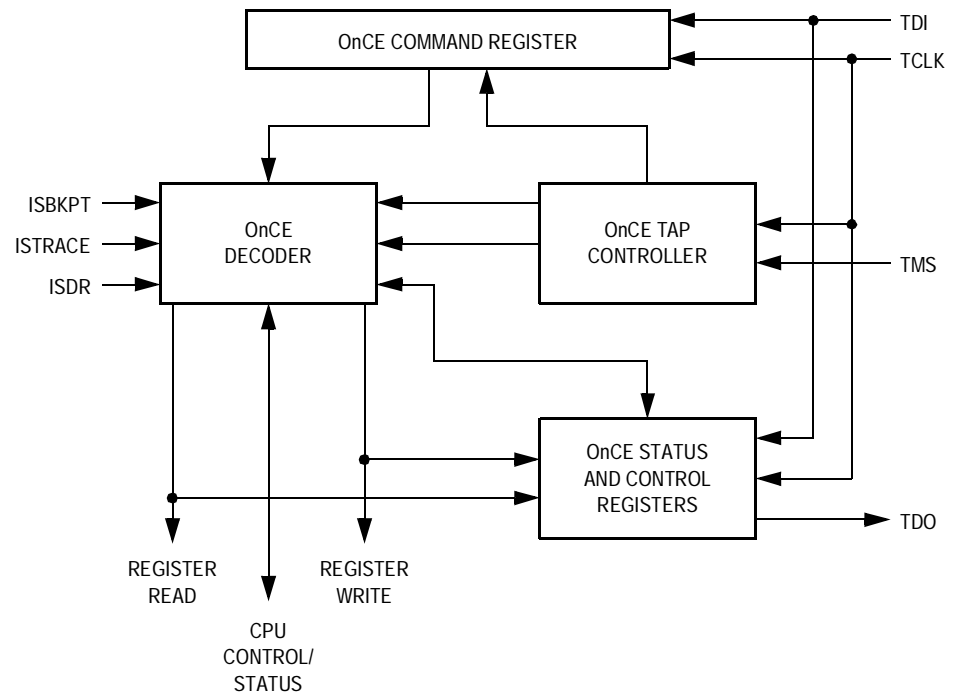

**Figure 22-7. OnCE Controller and Serial Interface**

### 22.14.3 OnCE Interface Signals

**Figure 22-8** shows the interface signals for the OnCE controller.

The following paragraphs describe the OnCE interface signals to other internal blocks associated with the OnCE controller. These signals are not available externally, and descriptions are provided to improve understanding of OnCE operation.

#### 22.14.3.1 Internal Debug Request Input ( $\overline{IDR}$ )

The internal debug request input is a hardware signal which is used in some implementations to force an immediate debug request to the CPU. If present and enabled, it functions in an identical manner to the control function provided by the DR control bit in the OCR. This input is maskable by a control bit in the OCR.

JTAG Test Access Port and OnCE

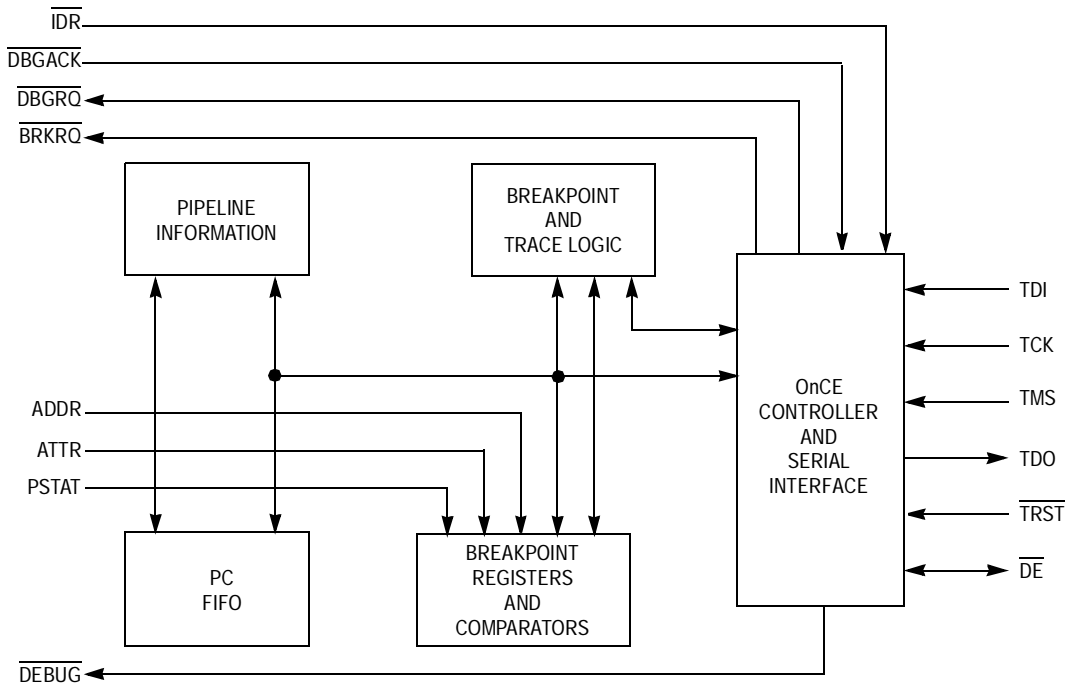

Figure 22-8. OnCE Interface Diagram

22.14.3.2 CPU Debug Request ( $\overline{DBGRQ}$ )

The  $\overline{DBGRQ}$  signal is asserted by the OnCE control logic to request the CPU to enter the debug state. It may be asserted for a number of different conditions. Assertion of this signal causes the CPU to finish the current instruction being executed, save the instruction pipeline information, enter debug mode, and wait for further commands. Asserting  $\overline{DBGRQ}$  causes the device to exit stop, doze, or wait mode.

22.14.3.3 CPU Debug Acknowledge ( $\overline{DBGACK}$ )

The CPU asserts the  $\overline{DBGACK}$  signal upon entering the debug state. This signal is part of the handshake mechanism between the OnCE control logic and the CPU.

22.14.3.4 CPU Breakpoint Request ( $\overline{BRKRQ}$ )

The  $\overline{BRKRQ}$  signal is asserted by the OnCE control logic to signal that a breakpoint condition has occurred for the current CPU bus access.

#### 22.14.3.5 CPU Address, Attributes (ADDR, ATTR)

The CPU address and attribute information may be used in the memory breakpoint logic to qualify memory breakpoints with access address and cycle type information.

#### 22.14.3.6 CPU Status (PSTAT)

The trace logic uses the PSTAT signals to qualify trace count decrements with specific CPU activity.

#### 22.14.3.7 OnCE Debug Output ( $\overline{DEBUG}$ )

The  $\overline{DEBUG}$  signal is used to indicate to on-chip resources that a debug session is in progress. Peripherals and other units may use this signal to modify normal operation for the duration of a debug session. This may involve the CPU executing a sequence of instructions solely for the purpose of visibility/system control. These instructions are not part of the normal instruction stream that the CPU would have executed had it not been placed in debug mode.

This signal is asserted the first time the CPU enters the debug state and remains asserted until the CPU is released by a write to the OnCE Command Register with the GO and EX bits set, and a register specified as either no register selected or the CPUSCR. This signal remains asserted even though the CPU may enter and exit the debug state for each instruction executed under control of the OnCE controller.

### 22.14.4 OnCE Controller Registers

This section describes the OnCE controller registers:

- OnCE Command Register (OCMR)
- OnCE Control Register (OCR)
- OnCE Status Register (OSR)

All OnCE registers are addressed by means of the RS field in the OCMR, as shown in [Table 22-4](#).

22.14.4.1 OnCE Command Register

The OnCE Command Register (OCMR) is an 8-bit shift register that receives its serial data from the TDI pin. This register corresponds to the JTAG IR and is loaded when the update-IR TAP controller state is entered. It holds the 8-bit commands shifted in during the shift-IR controller state to be used as input for the OnCE decoder. The OCMR contains fields for controlling access to a OnCE resource, as well as controlling single-step operation, and exit from OnCE mode.

Although the OCMR is updated during the update-IR TAP controller state, the corresponding resource is accessed in the DR scan sequence of the TAP controller, and as such, the update-DR state must be transitioned through in order for an access to occur. In addition, the update-DR state must also be transitioned through in order for the single-step and/or exit functionality to be performed, even though the command appears to have no data resource requirement associated with it.

Bit 7	6	5	4	3	2	1	Bit 0
R/W	G	EX	RS4	RS3	RS2	RS1	RS0

**Figure 22-9. OnCE Command Register (OCMR)**

R/W — Read/Write Bit

1 = Read the data in the register specified by the RS field.

0 = Write the data associated with the command into the register specified by the RS field.

GO — Go Bit

When the GO bit is set, the device executes the instruction in the IR Register in the CPUSCR. To execute the instruction, the processor leaves debug mode, executes the instruction, and if the EX bit is cleared, returns to debug mode immediately after executing the instruction. The processor resumes normal operation if the EX bit is set. The GO command is executed only if the operation is a read/write to either the CPUSCR or to “no register selected.” Otherwise, the GO

bit has no effect. The processor leaves debug mode after the TAP controller update-DR state is entered.

- 1 = Execute instruction in IR
- 0 = Inactive (no action taken)

#### EX — Exit Bit

When the EX bit is set, the processor leaves debug mode and resumes normal operation until another debug request is generated. The exit command is executed only if the GO bit is set and the operation is a read/write to the CPUSCR or a read/write to “no register selected.” Otherwise, the EX bit has no effect. The processor exits debug mode after the TAP controller update-DR state is entered.

- 1 = Leave debug mode
- 0 = Remain in debug mode

#### RS4–RS0 — Register Select Field

The RS field defines the source for the read operation or the destination for the write operation. [Table 22-4](#) shows OnCE register addresses.

**Table 22-4. OnCE Register Addressing**

RS4–RS0	Register Selected
00000	Reserved
00001	Reserved
00010	Reserved
00011	OTC — OnCE trace counter
00100	MBCA — memory breakpoint counter A
00101	MBCB — memory breakpoint counter B
00110	PC FIFO — program counter FIFO and increment counter
00111	BABA — Breakpoint Address Base Register A
01000	BABB — Breakpoint Address Base Register B
01001	BAMA — Breakpoint Address Mask Register A
01010	BAMB — Breakpoint Address Mask Register B
01011	CPUSCR — CPU Scan Chain Register
01100	Bypass — no register selected
01101	OCR — OnCE Control Register
01110	OSR — OnCE Status Register

Table 22-4. OnCE Register Addressing (Continued)

RS4–RS0	Register Selected
01111	Reserved (factory test control register — do not access)
10000	Reserved (MEM_BIST — do not access)
10001–10110	Reserved (bypass, do not access)
10111	Reserved (LSRL, do not access)
11000–11110	Reserved (bypass, do not access)
11111	Bypass

22.14.4.2 OnCE Control Register

The 32-bit OnCE Control Register (OCR) selects the events that put the device in debug mode and enables or disables sections of the OnCE logic.

	Bit 31	30	29	28	27	26	25	Bit 24
Read:	0	0	0	0	0	0	0	0
Write:								
Reset:	0	0	0	0	0	0	0	0
	Bit 23	22	21	20	19	18	17	Bit 16
Read:	0	0	0	0	0	0	SQC1	SQC0
Write:								
Reset:	0	0	0	0	0	0	0	0
	Bit 15	14	13	12	11	10	9	Bit 8
Read:	DR	IDRE	TME	FRZC	RCB	BCB4	BCB3	BCB2
Write:								
Reset:	0	0	0	0	0	0	0	0
	Bit 7	6	5	4	3	2	1	Bit 0
Read:	BCB1	BCB0	RCA	BCA4	BCA3	BCA2	BCA1	BCA0
Write:								
Reset:	0	0	0	0	0	0	0	0

= Unimplemented or reserved

Figure 22-10. OnCE Control Register (OCR)

**SQC1 and SQC0 — Sequential Control Field**

The SQC field allows memory breakpoint B and trace occurrences to be suspended until a qualifying event occurs. Test logic reset clears the SQC field. See [Table 22-5](#).

**Table 22-5. Sequential Control Field Settings**

SQC1 and SQC0	Meaning
00	Disable sequential control operation. Memory breakpoints and trace operation are unaffected by this field.
01	Suspend normal trace counter operation until a breakpoint condition occurs for memory breakpoint B. In this mode, memory breakpoint B occurrences no longer cause breakpoint requests to be generated. Instead, trace counter comparisons are suspended until the first memory breakpoint B occurrence. After the first memory breakpoint B occurrence, trace counter control is released to perform normally, assuming TME is set. This allows a sequence of breakpoint conditions to be specified prior to trace counting.
10	Qualify memory breakpoint B matches with a breakpoint occurrence for memory breakpoint A. In this mode, memory breakpoint A occurrences no longer cause breakpoint requests to be generated. Instead, memory breakpoint B comparisons are suspended until the first memory breakpoint A occurrence. After the first memory breakpoint A occurrence, memory breakpoint B is enabled to perform normally. This allows a sequence of breakpoint conditions to be specified.
11	Combine the 01 and 10 qualifications. In this mode, no breakpoint requests are generated, and trace count operation is enabled once a memory breakpoint B occurrence follows a memory breakpoint A occurrence if TME is set.

**DR — Debug Request Bit**

DR requests the CPU to enter debug mode unconditionally. The PM bits in the OnCE Status Register indicate that the CPU is in debug mode. Once the CPU enters debug mode, it returns there even with a write to the OCMR with GO and EX set until the DR bit is cleared. Test logic reset clears the DR bit.

**IDRE** — Internal Debug Request Enable Bit

The internal debug request ( $\overline{\text{IDR}}$ ) input to the OnCE control logic may not be used in all implementations. In some implementations, the  $\overline{\text{IDR}}$  control input may be connected and used as an additional hardware debug request. Test logic reset clears the IDRE bit.

1 =  $\overline{\text{IDR}}$  input enabled

0 =  $\overline{\text{IDR}}$  input disabled

**TME** — Trace Mode Enable Bit

TME enables trace operation. Test logic reset clears the TME bit.

Trace operation is also affected by the SQC field.

1 = Trace operation enabled

0 = Trace operation disabled

**FRZC** — Freeze Control Bit

This control bit is used in conjunction with memory breakpoint B registers to select between asserting a breakpoint condition when a memory breakpoint B occurs or freezing the PC FIFO from further updates when memory breakpoint B occurs while allowing the CPU to continue execution. The PC FIFO remains frozen until the FRZO bit in the OSR is cleared.

1 = Memory breakpoint B occurrence freezes PC FIFO and does not assert breakpoint condition.

0 = Memory breakpoint B occurrence asserts breakpoint condition.

**RCB and RCA** — Memory Breakpoint B and A Range Control Bits

RCB and RDA condition enabled memory breakpoint occurrences happen when memory breakpoint matches are either within or outside the range defined by memory base address and mask.

1 = Condition breakpoint on access outside of range

0 = Condition breakpoint on access within range

**BCB4–BCB0 and BCA4–BCA0** — Memory Breakpoint B and A Control Fields

The BCB and BCA fields enable memory breakpoints and qualify the access attributes to select whether the breakpoint matches are recognized for read, write, or instruction fetch (program space) accesses. Test logic reset clears BCB4–BCB0 and BCA4–BCA0.



**Table 22-6. Memory Breakpoint Control Field Settings**

<b>BCB4–BCB0 BCA4–BCA0</b>	<b>Description</b>
00000	Breakpoint disabled
00001	Qualify match with any access
00010	Qualify match with any instruction access
00011	Qualify match with any data access
00100	Qualify match with any change of flow instruction access
00101	Qualify match with any data write
00110	Qualify match with any data read
00111	Reserved
01XXX	Reserved
10000	Reserved
10001	Qualify match with any user access
10010	Qualify match with any user instruction access
10011	Qualify match with any user data access
10100	Qualify match with any user change of flow access
10101	Qualify match with any user data write
10110	Qualify match with any user data read
10111	Reserved
11000	Reserved
11001	Qualify match with any supervisor access
11010	Qualify match with any supervisor instruction access
11011	Qualify match with any supervisor data access
11100	Qualify match with any supervisor change of flow access
11101	Qualify match with any supervisor data write
11110	Qualify match with any supervisor data read
11111	Reserved

22.14.4.3 OnCE Status Register

The 16-bit OnCE Status Register (OSR) indicates the reason(s) that debug mode was entered and the current operating mode of the CPU.

	Bit 15	14	13	12	11	10	9	Bit 8
Read:	0	0	0	0	0	0	HDRO	DRO
Write:								
Reset:							0	0
	Bit 7	6	5	4	3	2	1	Bit 0
Read:	MBO	SWO	TO	FRZO	SQB	SQA	PM1	PM0
Write:								
Reset:	0	0	0	0	0	0	0	0

= Unimplemented or reserved

Figure 22-11. OnCE Status Register (OSR)

HDRO — Hardware Debug Request Occurrence Flag

HDRO is set when the processor enters debug mode as a result of a hardware debug request from the  $\overline{IDR}$  signal or the  $\overline{DE}$  pin. This bit is cleared on test logic reset or when debug mode is exited with the GO and EX bits set.

DRO — Debug Request Occurrence Flag

DRO is set when the processor enters debug mode and the debug request (DR) control bit in the OnCE Control Register is set. This bit is cleared on test logic reset or when debug mode is exited with the GO and EX bits set.

MBO — Memory Breakpoint Occurrence Flag

MBO is set when a memory breakpoint request has been issued to the CPU via the  $\overline{BRKRQ}$  input and the CPU enters debug mode. In some situations involving breakpoint requests on instruction prefetches, the CPU may discard the request along with the prefetch. In this case, this bit may become set due to the CPU entering debug mode for another reason. This bit is cleared on test logic reset or when debug mode is exited with the GO and EX bits set.

**SWO — Software Debug Occurrence Flag**

SWO bit is set when the processor enters debug mode of operation as a result of the execution of the BKPT instruction. This bit is cleared on test logic reset or when debug mode is exited with the GO and EX bits set.

**TO — Trace Count Occurrence Flag**

TO is set when the trace counter reaches zero with the trace mode enabled and the CPU enters debug mode. This bit is cleared on test logic reset or when debug mode is exited with the GO and EX bits set.

**FRZO — FIFO Freeze Occurrence Flag**

FRZO is set when a FIFO freeze occurs. This bit is cleared on test logic reset or when debug mode is exited with the GO and EX bits set.

**SQB — Sequential Breakpoint B Arm Occurrence Flag**

SQB is set when sequential operation is enabled and a memory breakpoint B event has occurred to enable trace counter operation. This bit is cleared on test logic reset or when debug mode is exited with the GO and EX bits set.

**SQA — Sequential Breakpoint A Arm Occurrence Flag**

SQA is set when sequential operation is enabled and a memory breakpoint A event has occurred to enable memory breakpoint B operation. This bit is cleared on test logic reset or when debug mode is exited with the GO and EX bits set.

**PM1 and PM0 — Processor Mode Field**

These flags reflect the processor operating mode. They allow coordination of the OnCE controller with the CPU for synchronization.

**Table 22-7. Processor Mode Field Settings**

<b>PM1 and PM0</b>	<b>Meaning</b>
00	Processor in normal mode
01	Processor in stop, doze, or wait mode
10	Processor in debug mode
11	Reserved

### 22.14.5 OnCE Decoder (ODEC)

The ODEC receives as input the 8-bit command from the OCMR and status signals from the processor. The ODEC generates all the strobes required for reading and writing the selected OnCE registers.

### 22.14.6 Memory Breakpoint Logic

Memory breakpoints can be set for a particular memory location or on accesses within an address range. The breakpoint logic contains an input latch for addresses, registers that store the base address and address mask, comparators, attribute qualifiers, and a breakpoint counter. **Figure 22-12** illustrates the basic functionality of the OnCE memory breakpoint logic. This logic is duplicated to provide two independent breakpoint resources.

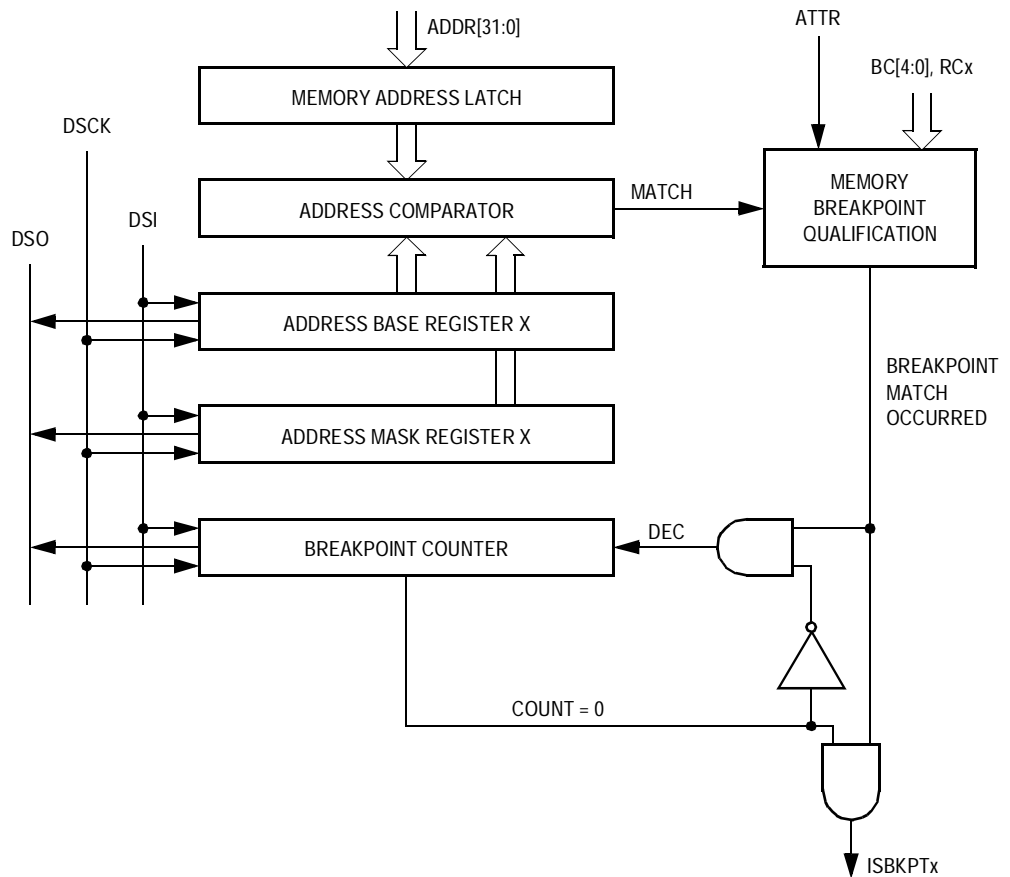

Figure 22-12. OnCE Memory Breakpoint Logic

Address comparators can be used to determine where a program may be getting lost or when data is being written to areas which should not be written. They are also useful in halting a program at a specific point to examine or change registers or memory. Using address comparators to set breakpoints enables the user to set breakpoints in RAM or ROM in any operating mode. Memory accesses are monitored according to the contents of the OCR.

The address comparator generates a match signal when the address on the bus matches the address stored in the Breakpoint Address Base Register, as masked with individual bit masking capability provided by the Breakpoint Address Mask Register. The address match signal and the access attributes are further qualified with the RCx4–RCx0 and BCx4–BCx0 control bits. This qualification is used to decrement the breakpoint counter conditionally if its contents are non-zero. If the contents are zero, the counter is not decremented and the breakpoint event occurs (ISBKPTx asserted).

#### 22.14.6.1 Memory Address Latch (MAL)

The MAL is a 32-bit register that latches the address bus on every access.

#### 22.14.6.2 Breakpoint Address Base Registers

The 32-bit Breakpoint Address Base Registers (BABA and BABB) store memory breakpoint base addresses. BABA and BABB can be read or written through the OnCE serial interface. Before enabling breakpoints, the external command controller should load these registers.

### 22.14.7 Breakpoint Address Mask Registers

The 32-bit Breakpoint Address Mask Registers (BAMA and BAMB) registers store memory breakpoint base address masks. BAMA and BAMB can be read or written through the OnCE serial interface. Before enabling breakpoints, the external command controller should load these registers.

### 22.14.7.1 Breakpoint Address Comparators

The breakpoint address comparators are not externally accessible. Each compares the memory address stored in MAL with the contents of BABx, as masked by BAMx, and signals the control logic when a match occurs.

### 22.14.7.2 Memory Breakpoint Counters

The 16-bit Memory Breakpoint Counter Registers (MBCA and MBCB) are loaded with a value equal to the number of times, minus one, that a memory access event should occur before a memory breakpoint is declared. The memory access event is specified by the RCx4–RCx0 and BCx4–BCx0 bits in the OCR and by the Memory Base and Mask Registers. On each occurrence of the memory access event, the breakpoint counter, if currently non-zero, is decremented. When the counter has reached the value of zero and a new occurrence takes place, the  $\overline{\text{ISBKPTx}}$  signal is asserted and causes the CPU's  $\overline{\text{BRKRQ}}$  input to be asserted. The MBCx can be read or written through the OnCE serial interface.

Anytime the breakpoint registers are changed, or a different breakpoint event is selected in the OCR, the breakpoint counter must be written afterward. This assures that the OnCE breakpoint logic is reset and that no previous events will affect the new breakpoint event selected.

### 22.14.8 OnCE Trace Logic

The OnCE trace logic allows the user to execute instructions in single or multiple steps before the device returns to debug mode and awaits OnCE commands from the debug serial port. The OnCE trace logic is independent of the M•CORE trace facility, which is controlled through the trace mode bits in the M•CORE Processor Status Register. The OnCE trace logic block diagram is shown in [Figure 22-13](#).

22.14.8.1 OnCE Trace Counter

The OnCE Trace Counter Register (OTC) is a 16-bit counter that allows more than one instruction to be executed in real time before the device returns to debug mode. This feature helps the software developer debug sections of code that are time-critical. The trace counter also enables the user to count the number of instructions executed in a code segment.

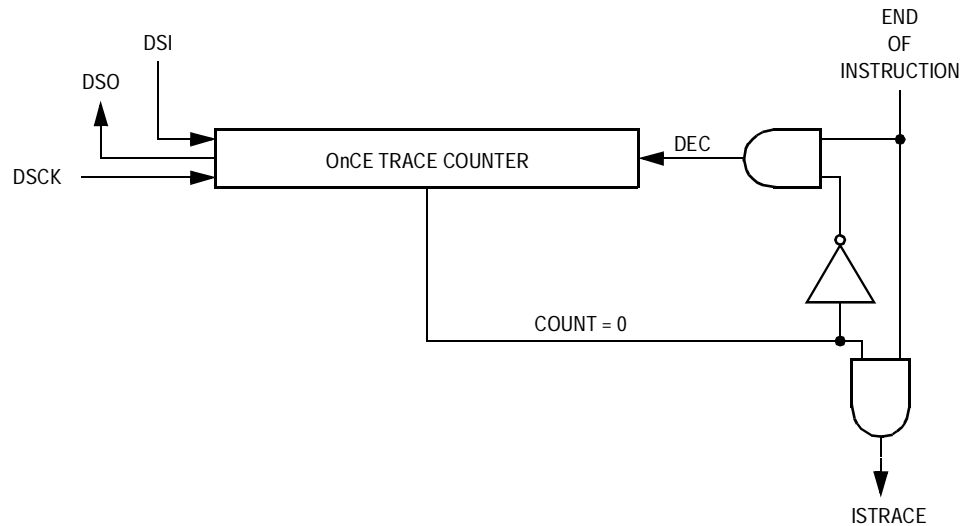

**Figure 22-13. OnCE Trace Logic Block Diagram**

The OTC Register can be read, written, or cleared through the OnCE serial interface. If N instructions are to be executed before entering debug mode, the trace counter should be loaded with N – 1. N must not equal zero unless the sequential breakpoint control capability is being used. In this case a value of zero (indicating a single instruction) is allowed.

A hardware reset clears the OTC.

### 22.14.8.2 Trace Operation

To initiate trace mode operation:

1. Load the OTC Register with a value. This value must be non-zero, unless sequential breakpoint control operation is enabled in the OCR Register. In this case, a value of zero (indicating a single instruction) is allowed.
2. Initialize the program counter and Instruction Register in the CPUSCR with values corresponding to the start location of the instruction(s) to be executed real-time.
3. Set the TME bit in the OCR.
4. Release the processor from debug mode by executing the appropriate command issued by the external command controller.

When debug mode is exited, the counter is decremented after each execution of an instruction. Interrupts can be serviced, and all instructions executed (including interrupt services) will decrement the trace counter.

When the trace counter decrements to zero, the OnCE control logic requests that the processor re-enter debug mode, and the trace occurrence bit TO in the OSR is set to indicate that debug mode has been requested as a result of the trace count function. The trace counter allows a minimum of two instructions to be specified for execution prior to entering trace (specified by a count value of one), unless sequential breakpoint control operation is enabled in the OCR. In this case, a value of zero (indicating a single instruction) is allowed.

### 22.14.9 Methods of Entering Debug Mode

The PM status field in the OSR indicates that the CPU has entered debug mode. The following paragraphs discuss conditions that invoke debug mode.

#### 22.14.9.1 Debug Request During $\overline{\text{RESET}}$

When the DR bit in the OCR is set, assertion of  $\overline{\text{RESET}}$  causes the device to enter debug mode. In this case the device may fetch the reset



vector and the first instruction of the reset exception handler but does not execute an instruction before entering debug mode.

#### 22.14.9.2 Debug Request During Normal Activity

Setting the DR bit in the OCR during normal device activity causes the device to finish the execution of the current instruction and then enter debug mode. Note that in this case the device completes the execution of the current instruction and stops after the newly fetched instruction enters the CPU instruction latch. This process is the same for any newly fetched instruction, including instructions fetched by interrupt processing or those that will be aborted by interrupt processing.

#### 22.14.9.3 Debug Request During Stop, Doze, or Wait Mode

Setting the DR bit in the OCR when the device is in stop, doze, or wait mode (for instance, after execution of a STOP, DOZE, or WAIT instruction) causes the device to exit the low-power state and enter the debug mode. Note that in this case, the device completes the execution of the STOP, DOZE, or WAIT instruction and halts after the next instruction enters the instruction latch.

#### 22.14.9.4 Software Request During Normal Activity

Executing the BKPT instruction when the FDB (force debug enable mode) control bit in the Control State Register is set causes the CPU to enter debug mode after the instruction following the BKPT instruction has entered the instruction latch.

### 22.14.10 Enabling OnCE Trace Mode

When the OnCE trace mode mechanism is enabled and the trace count is greater than zero, the trace counter is decremented for each instruction executed. Completing execution of an instruction when the trace counter is zero causes the CPU to enter debug mode.

**NOTE:** *Only instructions actually executed cause the trace counter to decrement. An aborted instruction does not decrement the trace counter and does not invoke debug mode.*

### 22.14.11 Enabling OnCE Memory Breakpoints

When the OnCE memory breakpoint mechanism is enabled with a breakpoint counter value of zero, the device enters debug mode after completing the execution of the instruction that caused the memory breakpoint to occur. In case of breakpoints on instruction fetches, the breakpoint is acknowledged immediately after the execution of the fetched instruction. In case of breakpoints on data memory addresses, the breakpoint is acknowledged after the completion of the memory access instruction.

### 22.14.12 Pipeline Information and Write-Back Bus Register

A number of on-chip registers store the CPU pipeline status and are configured in the CPU Scan Chain Register (CPUSCR) for access by the OnCE controller. The CPUSCR is used to restore the pipeline and resume normal device activity upon return from debug mode. The CPUSCR also provides a mechanism for the emulator software to access processor and memory contents. **Figure 22-14** shows the block diagram of the pipeline information registers contained in the CPUSCR.

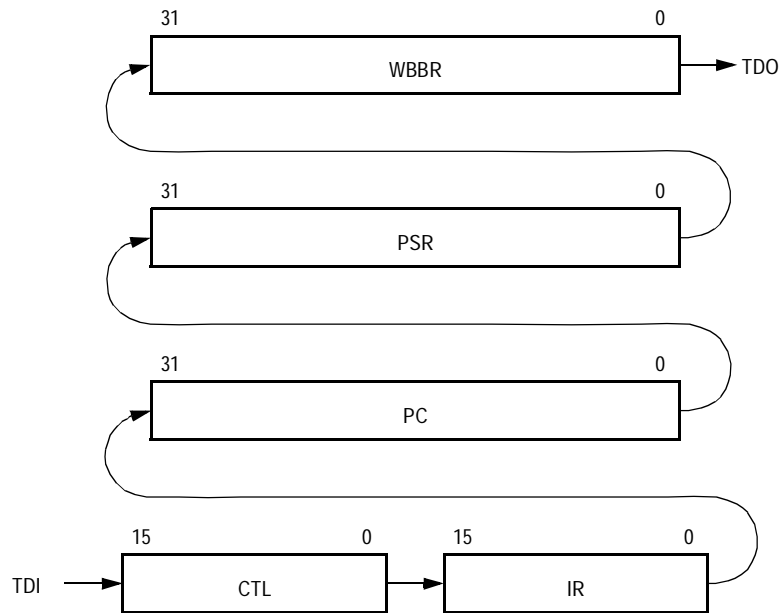

**Figure 22-14. CPU Scan Chain Register (CPUSCR)**

### 22.14.12.1 Program Counter Register

The Program Counter Register (PC) is a 32-bit latch that stores the value in the CPU program counter when the device enters debug mode. The CPU PC is affected by operations performed during debug mode and must be restored by the external command controller when the CPU returns to normal mode.

### 22.14.12.2 Instruction Register

The Instruction Register (IR) provides a mechanism for controlling the debug session. The IR allows the debug control block to execute selected instructions; the debug control module provides single-step capability.

When scan-out begins, the IR contains the opcode of the next instruction to be executed at the time debug mode was entered. This opcode must be saved in order to resume normal execution at the point debug mode was entered.

On scan-in, the IR can be filled with an opcode selected by debug control software in preparation for exiting debug mode. Selecting appropriate instructions allows a user to examine or change memory locations and processor registers.

Once the debug session is complete and normal processing is to be resumed, the IR can be loaded with the value originally scanned out.

### 22.14.12.3 Control State Register

The Control State Register (CTL) is used to set control values when debug mode is exited. On scan-in, this register is used to control specific aspects of the CPU. Certain bits reflect internal processor status and should be restored to their original values.

The CTL register is a 16-bit latch that stores the value of certain internal CPU state variables before debug mode is entered. This register is affected by the operations performed during the debug session and should be restored by the external command controller when returning to normal mode. In addition to saved internal state variables, the bits are used by emulation firmware to control the debug process.

Reserved bits represent the internal processor state. Restore these bits to their original value after a debug session is completed, for example, when a OnCE command is issued with the GO and EX bits set and not ignored. Set these bits to 1s while instructions are executed during a debug session.

	Bit 15	14	13	12	11	10	9	Bit 8
Read:	RSVD	RSVD	RSVD	RSVD	RSVD	RSVD	RSVD	FFY
Write:	RSVD	RSVD	RSVD	RSVD	RSVD	RSVD	RSVD	FFY
Reset:								0
	Bit 7	6	5	4	3	2	1	Bit 0
Read:	FDB	SZ1	SZ0	TC2	TC1	TC0	RSVD	RSVD
Write:	FDB	SZ1	SZ0	TC2	TC1	TC0	RSVD	RSVD
Reset:	0	0	0	0	0	0		

**Figure 22-15. Control State Register (CTL)**

**FFY — Feed Forward Y Operand Bit**

This control bit is used to force the content of the WBBR to be used as the Y operand value of the first instruction to be executed following an update of the CPUSCR. This gives the debug firmware the capability of updating processor registers by initializing the WBBR with the desired value, setting the FFY bit, and executing a MOV instruction to the desired register.

**FDB — Force Debug Enable Mode Bit**

Setting this control bit places the processor in debug enable mode. In debug enable mode, execution of the BKPT instruction as well as recognition of the  $\overline{\text{BRKRQ}}$  input causes the processor to enter debug mode, as if the  $\overline{\text{DBGRQ}}$  input had been asserted.

**SZ1 and SZ0 — Prefetch Size Field**

This control field is used to drive the CPU SIZ1 and SIZ0 outputs on the first instruction pre-fetch caused by issuing a OnCE command with the GO bit set and not ignored. It should be set to indicate a 16-bit size, for example, 0b10. This field should be restored to its original value after a debug session is completed, for example, when a OnCE command is issued with the GO and EX bits set and not ignored.

### TC — Prefetch Transfer Code

This control field is used to drive the CPU TC2–TC0 outputs on the first instruction pre-fetch caused by issuing a OnCE command with the GO bit set and not ignored. It should typically be set to indicate a supervisor instruction access, for example, 0b110. This field should be restored to its original value after a debug session is completed, for example, when a OnCE command is issued with the GO and EX bits set and not ignored.

#### 22.14.12.4 Writeback Bus Register

The Writeback Bus Register (WBBR) is a means of passing operand information between the CPU and the external command controller. Whenever the external command controller needs to read the contents of a register or memory location, it forces the device to execute an instruction that brings that information to WBBR.

For example, to read the content of processor register r0, a MOV r0,r0 instruction is executed, and the result value of the instruction is latched into the WBBR. The contents of WBBR can then be delivered serially to the external command controller.

To update a processor resource, this register is initialized with a data value to be written, and a MOV instruction is executed which uses this value as a write-back data value. The FFY bit in the CTL Register forces the value of the WBBR to be substituted for the normal source value of a MOV instruction, thus allowing updates to processor registers to be performed.

#### 22.14.12.5 Processor Status Register

The Processor Status Register (PSR) is a 32-bit latch used to read or write the M•CORE Processor Status Register. Whenever the external command controller needs to save or modify the contents of the M•CORE Processor Status Register, the PSR is used. This register is affected by the operations performed in debug mode and must be restored by the external command controller when returning to normal mode.

22.14.13 Instruction Address FIFO Buffer (PC FIFO)

To ease debugging activity and keep track of program flow, a first-in-first-out (FIFO) buffer stores the addresses of the last eight instruction change-of-flow prefetches that were issued.

The FIFO is a circular buffer containing eight 32-bit registers and one 3-bit counter. All the registers have the same address, but any read access to the FIFO address causes the counter to increment and point to the next FIFO register. The registers are serially available to the external command controller through the common FIFO address.

Figure 22-16 shows the structure of the PC FIFO.

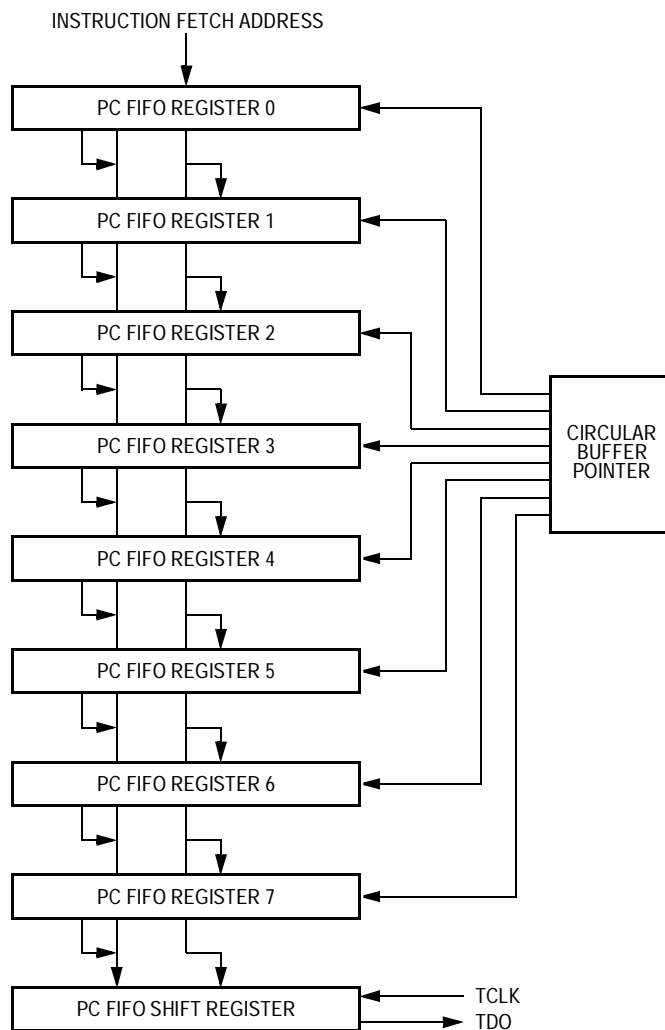

Figure 22-16. OnCE PC FIFO

The FIFO is not affected by operations performed in debug mode, except for incrementing the FIFO pointer when the FIFO is read. When debug mode is entered, the FIFO counter points to the FIFO register containing the address of the oldest of the eight change-of-flow pre-fetches. The first FIFO read obtains the oldest address, and the following FIFO reads return the other addresses from the oldest to the newest, in order of execution.

To ensure FIFO coherence, a complete set of eight reads of the FIFO must be performed. Each read increments the FIFO pointer, causing it to point to the next location. After eight reads, the pointer points to the same location as before the start of the read procedure.

The data in the FIFO is not affected by the read operations.

#### 22.14.14 Reserved Test Control Registers

The reserved test control registers (MEM\_BIST, FTCCR, and LSRL) are reserved for factory testing.

**CAUTION:** *To prevent damage to the device or system, do not access these registers during normal operation.*

#### 22.14.15 Serial Protocol

The serial protocol permits an efficient means of communication between the OnCE external command controller and the MCU. Before starting any debugging activity, the external command controller must wait for an acknowledgment that the device has entered debug mode. The external command controller communicates with the device by sending 8-bit commands to the OnCE Command Register and 16 to 128 bits of data to one of the other OnCE registers. Both commands and data are sent or received LSB first. After sending a command, the external command controller must wait for the processor to acknowledge execution of certain commands before it can properly access another OnCE Register.

### 22.14.16 OnCE Commands

The OnCE commands can be classified as:

- Read commands (the device delivers the required data)
- Write commands (the device receives data and writes the data in one of the OnCE registers)
- Commands with no associated data transfers

### 22.14.17 Target Site Debug System Requirements

A typical debug environment consists of a target system in which the MCU resides in the user-defined hardware.

The external command controller acts as the medium between the MCU target system and a host computer. The external command controller circuit acts as a serial debug port driver and host computer command interpreter. The controller issues commands based on the host computer inputs from a user interface program which communicates with the user.

### 22.14.18 Interface Connector for JTAG/OnCE Serial Port

**Figure 22-17** shows the recommended connector pinout and interface requirements for debug controllers that access the JTAG/OnCE port. The connector has two rows of seven pins with 0.1-inch center-to-center spacing between pins in each row and each column.



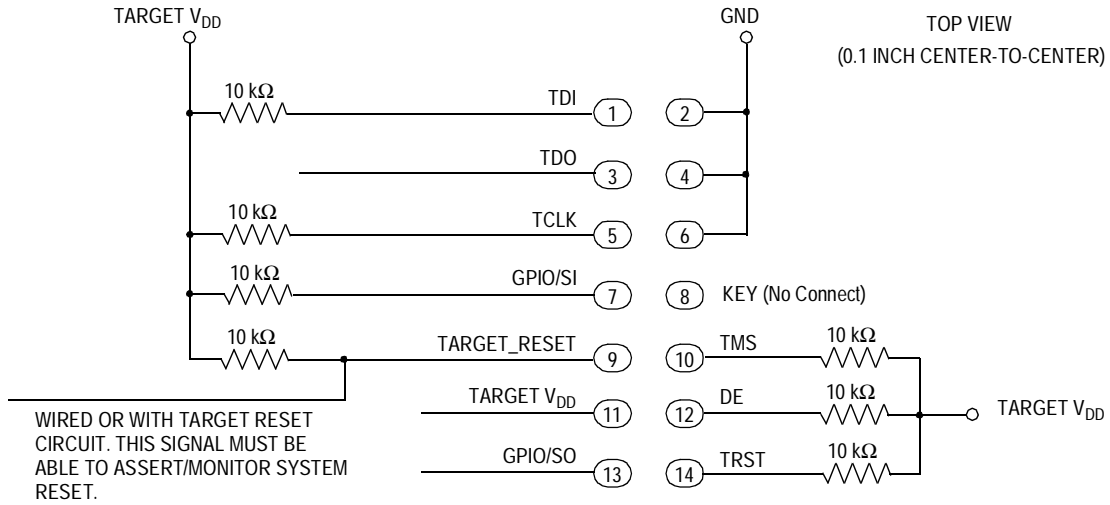

Note: GPIO/SI and GPIO/SO are not required for OnCE operation at this time. These pins can be used for high-speed downloads with a recommended interface.

**Figure 22-17. Recommended Connector Interface to JTAG/OnCE Port**



## Section 23. Preliminary Electrical Specifications

### 23.1 Contents

23.2	Introduction . . . . .	612
23.3	Absolute Maximum Ratings . . . . .	613
23.4	Thermal Characteristics . . . . .	614
23.5	Junction Temperature Determination . . . . .	614
23.6	Electrostatic Discharge (ESD) Protection . . . . .	615
23.7	DC Electrical Specifications . . . . .	616
23.8	PLL Electrical Specifications . . . . .	618
23.9	QADC Electrical Characteristics . . . . .	620
23.10	FLASH Memory Characteristics . . . . .	624
23.11	External Interface Timing Characteristics . . . . .	625
23.12	General Purpose I/O Timing . . . . .	630
23.13	Reset and Configuration Override Timing . . . . .	631
23.14	SPI Timing Characteristics . . . . .	632
23.15	OnCE, JTAG, and Boundary Scan Timing . . . . .	635

Preliminary

## 23.2 Introduction

This section contains electrical and specification tables and reference timing diagrams for the MMC2114 microcontroller unit (MCU). This section contains detailed information on power considerations, DC/AC electrical characteristics, and AC timing specifications of MMC2114.

The electrical specifications are preliminary and are from previous designs or design simulations. These specifications may not be fully tested or guaranteed at this early stage of the product life cycle; however, for production silicon these specifications will be met. Finalized specifications will be published after complete characterization and device qualifications have been completed.

**NOTE:** *The parameters specified in this MCU document supersede any values found in the module specifications.*

## 23.3 Absolute Maximum Ratings

Maximum ratings are the extreme limits to which the MCU can be exposed without permanently damaging it. See [Table 23-1](#).

The MCU contains circuitry to protect the inputs against damage from high static voltages; however, do not apply voltages higher than those shown in the table. Keep  $V_{In}$  and  $V_{Out}$  within the range  $V_{SS} \leq (V_{In} \text{ or } V_{Out}) \leq V_{DD}$ . Connect unused inputs to the appropriate voltage level, either  $V_{SS}$  or  $V_{DD}$ . This device is not guaranteed to operate properly at the maximum ratings. Refer to [23.7 DC Electrical Specifications](#) for guaranteed operating conditions.

**Table 23-1. Absolute Maximum Ratings**

Parameter	Symbol	Value	Unit
Supply voltage	$V_{DD}$	-0.3 to +4.0	V
Clock synthesizer (PLL) supply voltage	$V_{DD}$	-0.3 to +4.0	V
RAM memory standby supply voltage	$V_{STBY}$	-0.3 to + 4.0	V
FLASH memory supply voltage	$V_{DDF}$	-0.3 to +4.0	V
Analog supply voltage	$V_{DDA}$	-0.3 to +6.0	V
Analog reference supply voltage	$V_{RH}$	-0.3 to +6.0	V
Analog ESD protection voltage	$V_{DDH}$	-0.3 to +6.0	V
Digital input voltage <sup>(1)</sup>	$V_{IN}$	-0.3 to + 5.0	V
Analog input voltage	$V_{AIN}$	-0.3 to + 6.0	V
Instantaneous maximum current single pin limit (applies to all pins) <sup>(2), (3)</sup>	$I_D$	25	mA
Operating temperature range (packaged)	$T_A$ ( $T_L$ to $T_H$ )	-40 to 85	°C
Storage temperature range	$T_{STG}$	-65 to 150	°C

- Input must be current limited to the value specified. To determine the value of the required current-limiting resistor, calculate resistance values for positive and negative clamp voltages, then use the larger of the two values.
- All functional non-supply pins are internally clamped to  $V_{SS}$  and  $V_{DD}$ .
- Power supply must maintain regulation within operating  $V_{DD}$  range during instantaneous and operating maximum current conditions. If positive injection current ( $V_{in} > V_{DD}$ ) is greater than  $I_{DD}$ , the injection current may flow out of  $V_{DD}$  and could result in external power supply going out of regulation. Ensure external  $V_{DD}$  load will shunt current greater than maximum injection current. This will be the greatest risk when the MCU is not consuming power (ex; no clock). Power supply must maintain regulation within operating  $V_{DD}$  range during instantaneous and operating maximum current conditions.

## 23.4 Thermal Characteristics

**Table 23-2. Thermal Characteristics**

Parameter	Symbol	Value	Unit
Thermal Resistance			
Plastic 100-pin LQFP surface mount	$\theta_{JA}$	44	°C/W
Plastic 144-pin LQFP surface mount		46	
Plastic 196-ball MAPBGA		60	

## 23.5 Junction Temperature Determination

The average chip-junction temperature ( $T_J$ ) in °C can be obtained from:

$$T_J = T_A + P_D \times \theta_{JA} \quad (1)$$

where:

$T_A$  = Ambient temperature, °C

$\theta_{JA}$  = Package thermal resistance, junction-to-ambient, °C/W

$P_D$  =  $P_{INT} + P_{I/O}$

$P_{INT}$  =  $I_{DD} \times V_{DD}$ , watts — chip internal power

$P_{I/O}$  = Power dissipation on input and output pins — user determined

For most applications,  $P_{I/O} < P_{INT}$  and can be neglected. An approximate relationship between  $P_D$  and  $T_J$  (if  $P_{I/O}$  is neglected) is:

$$P_D = K \div (T_J + 273^\circ\text{C}) \quad (2)$$

Solving equations 1 and 2 for K gives:

$$K = P_D \times (T_A + 273^\circ\text{C}) + \theta_{JA} \times P_D^2 \quad (3)$$

where K is a constant pertaining to the particular part. K can be determined from equation (3) by measuring  $P_D$  (at equilibrium) for a known  $T_A$ . Using this value of K, the values of  $P_D$  and  $T_J$  can be obtained by solving equations (1) and (2) iteratively for any value of  $T_A$ .

## 23.6 Electrostatic Discharge (ESD) Protection

**Table 23-3. ESD Protection Characteristics**

Parameter <sup>(1), (2)</sup>	Symbol	Value	Units
ESD target for human body model	HBM	2000	V
ESD target for machine model	MM	200	V
HBM circuit description	R <sub>Series</sub>	1500	W
	C	100	pF
MM circuit description	R <sub>Series</sub>	0	W
	C	200	pF
Number of pulses per pin (HBM)			
Positive pulses	—	1	—
Negative pulses		1	
Number of pulses per pin (MM)			
Positive pulses	—	3	—
Negative pulses		3	
Interval of pulses	—	1	Sec

1. All ESD testing is in conformity with CDF-AEC-Q100 Stress Test Qualification for Automotive Grade Integrated Circuits.
2. A device will be defined as a failure if after exposure to ESD pulses the device no longer meets the device specification requirements. Complete DC parametric and functional testing shall be performed per applicable device specification at room temperature followed by hot temperature, unless specified otherwise in the device specification.

Preliminary

**Preliminary Electrical Specifications**
**23.7 DC Electrical Specifications**
**Table 23-4. DC Electrical Specifications<sup>(1)</sup>**  
**( $V_{SS} = V_{SSF} = V_{SSA} = 0\text{ V}$ ,  $T_A = T_L$  to  $T_H$ )**

Parameter	Symbol	Min	Max	Unit
Input high voltage	$V_{IH}$	$0.7 \times V_{DD}$	5	V
Input low voltage	$V_{IL}$	$V_{SS} - 0.3$	$0.35 \times V_{DD}$	V
Input hysteresis	$V_{HYS}$	$0.06 \times V_{DD}$	—	V
Input leakage current, $V_{In} = V_{DD}$ or $V_{SS}$ , input-only pins	$I_{In}$	-1.0	1.0	$\mu\text{A}$
High impedance (off-state) leakage current $V_{In} = V_{DD}$ or $V_{SS}$ , all input/output and output pins	$I_{OZ}$	-1.0	1.0	$\mu\text{A}$
Output high voltage (all input/output and all output pins) $I_{OH} = -2.0\text{ mA}$	$V_{OH}$	$V_{DD} - 0.5$	—	V
Output low voltage (all input/output and all output pins) $I_{OL} = 2.0\text{ mA}$	$V_{OL}$	—	0.5	V
Weak internal pullup device current, tested at $V_{IL}$ maximum	$I_{APU}$	-10	-130	$\mu\text{A}$
Input capacitance All input-only pins All input/output (three-state) pins	$C_{In}$	— —	7 7	pF
Load Capacitance 50% partial drive 100% full drive	$C_L$	— —	25 50	pF
Supply voltage, includes core modules and pads	$V_{DD}$	2.7	3.6	V
RAM memory standby supply voltage Normal operation: $V_{DD} > V_{STBY} - 0.3\text{ V}$ Standby mode: $V_{DD} < V_{STBY} - 0.3\text{ V}$	$V_{STBY}$	0.0 2.7	3.6 3.6	V
FLASH memory supply voltage	$V_{DDF}$	2.7	3.6	V
Low-voltage detect trip voltage ( $V_{DD}$ falling)	$V_{LDV}$	2.00	2.20	V
Low-voltage detect hysteresis ( $V_{DD}$ rising)	$V_{HYS}$	60	100	mV
$V_{DD}$ slew rate (rising or falling) for LVD recognition	$V_{SLEWLVD}$	—	5	kV/ms
Operating supply current, external oscillator clocking <sup>(2)</sup> Master mode Single-chip mode Wait mode Doze mode Stop mode	$I_{DD}$	— — — — —	60 40 15 10 200	mA mA mA mA $\mu\text{A}$

Continued on next page



**Table 23-4. DC Electrical Specifications<sup>(1)</sup> (Continued)**  
 $(V_{SS} = V_{SSF} = V_{SSA} = 0\text{ V}, T_A = T_L \text{ to } T_H)$ 

Parameter	Symbol	Min	Max	Unit
Operating supply current, crystal/PLL clocking <sup>(3)</sup>				
Master mode		—	64	mA
Single-chip mode		—	44	mA
Wait mode		—	19	mA
Doze mode		—	14	mA
Stop mode				
OSC and PLL enabled	$I_{DDXTAL}$	—	2	mA
OSC enabled, PLL disabled		—	1	mA
OSC and PLL disabled		—	200	$\mu\text{A}$
RAM memory standby supply current				
Normal operation: $V_{DD} > V_{STBY} - 0.3\text{ V}$	$I_{STBY}$	—	10	$\mu\text{A}$
Transient condition: $V_{STBY} - 0.3\text{ V} > V_{DD} > V_{SS} + 0.5\text{ V}$		—	7	mA
Standby operation: $V_{DD} < V_{SS} + 0.5\text{ V}$		—	20	$\mu\text{A}$
FLASH memory supply current <sup>(4)</sup>				
Read		—	5	mA
Program	$I_{DDF}$	—	28	mA
Erase or mass erase		—	20	mA
Stop mode		—	1	$\mu\text{A}$
Analog supply current				
Normal operation	$I_{DDA}$	—	2	mA
Stop mode		—	10.0	$\mu\text{A}$
ESD supply current				
Normal operation	$I_{DDH}$	—	800	$\mu\text{A}$
Stop mode		—	10	
DC injection current <sup>(4), (5), (6)</sup>				
$V_{NEGCLAMP} = V_{SS} - 0.3\text{ V}, V_{POSCLAMP} = V_{DD} + 0.3$	$I_{IC}$			
Single pin limit		-1.0	1.0	mA
Total MCU limit, includes sum of all stressed pins		-10	10	

1. Refer to [Table 23-5](#) through [Table 23-10](#) for additional PLL, QADC and FLASH specifications.
2. Current measured at maximum system clock frequency (unless indicated otherwise), all modules active, and default drive strength with matching load.
3. Current measured at  $f_{SYS} = 32\text{ MHz}$  derived from 8.00 MHz crystal and PLL, all modules active, and default drive strength with matching load.
4. All functional non-supply pins are internally clamped to  $V_{SS}$  and their respective  $V_{DD}$ .
5. Input must be current limited to the value specified. To determine the value of the required current-limiting resistor, calculate resistance values for positive and negative clamp voltages, then use the larger of the two values.
6. Power supply must maintain regulation within operating  $V_{DD}$  range during instantaneous and operating maximum current conditions. If positive injection current ( $V_{in} > V_{DD}$ ) is greater than  $I_{DD}$ , the injection current may flow out of  $V_{DD}$  and could result in external power supply going out of regulation. Ensure external  $V_{DD}$  load will shunt current greater than maximum injection current. This will be the greatest risk when the MCU is not consuming power. Examples are: if no system clock is present, or if clock rate is very low which would reduce overall power consumption. Also, at power-up, system clock is not present during the power-up sequence until the PLL has attained lock.

**Preliminary Electrical Specifications**
**23.8 PLL Electrical Specifications**
**Table 23-5. PLL Electrical Specifications**  
 ( $V_{DD} = 2.7$  to  $3.6$  V,  $V_{SS} = 0$  V,  $T_A = T_L$  to  $T_H$ )

Characteristic	Symbol	Min	Max	Unit
PLL reference frequency range				
Crystal reference <sup>(1)</sup>	$f_{ref\_Crystal}$	2	10	MHz
External reference	$f_{ref\_ext}$	2	10	
1:1 mode	$f_{ref\_1:1}$	10	33	
System frequency <sup>(2)</sup>				
External reference	$f_{sys}$	0	33	MHz
On-chip PLL frequency		3/64	33	
Loss of reference frequency <sup>(3), (4)</sup>	$f_{LOR}$	100	250	kHz
Self-clocked mode frequency <sup>(4)</sup>	$f_{SCM}$	0.5	15	MHz
Crystal startup time <sup>(5), (6)</sup>	$t_{CST}$	—	10	ms
EXTAL input high voltage				
Crystal mode	$V_{IHEXT}$	$V_{DD} - 1.0$	$V_{DD}$	V
All other modes (1:1, bypass, external)		2.0	$V_{DD}$	
EXTAL input low voltage				
Crystal mode	$V_{ILEXT}$	$V_{SS}$	1.0	V
All other modes (1:1, bypass, external)		$V_{SS}$	0.8	
XTAL output high voltage				
$I_{OH} = 1.0$ mA	$V_{OL}$	$V_{DD} - 1.0$	—	V
XTAL output low voltage				
$I_{OL} = 1.0$ mA	$V_{OL}$	—	0.5	V
XTAL load capacitance		5	30	pF
PLL lock time <sup>(4), (7)</sup>	$t_{LPLL}$	—	200	$\mu$ s
Powerup to lock time <sup>(4), (5), (8)</sup>				
With crystal reference (includes P5 time)	$t_{LPLK}$	—	11	ms
Without crystal reference		—	200	$\mu$ s
1:1 clock skew (between CLKOUT and EXTAL) <sup>(9)</sup>	$t_{Skew}$	-2	2	ns
Duty cycle of reference <sup>(4)</sup>	$t_{dc}$	40	60	% $f_{sys}$
Frequency unlock range	$f_{UL}$	-1.5	1.5	% $f_{sys}$
Frequency lock range	$f_{LCK}$	-0.75	0.75	% $f_{sys}$

Continued on next page

**Table 23-5. PLL Electrical Specifications (Continued)**  
**( $V_{DD} = 2.7$  to  $3.6$  V,  $V_{SS} = 0$  V,  $T_A = T_L$  to  $T_H$ )**

Characteristic	Symbol	Min	Max	Unit
CLKOUT period jitter <sup>(4), (5), (7), (10)</sup> measured at $f_{sys}$ max Peak-to-peak jitter (clock edge to clock edge) Long term jitter (averaged over 2 ms interval)	$C_{Jitter}$	— —	5 0.01	% $f_{sys}$

1. When the MFD in the PLL is set to 000, the minimum crystal reference frequency is 3 MHz.
2. All internal registers retain data at 0 Hz.
3. "Loss of reference frequency" is the reference frequency detected internally, which transitions the PLL into self-clocked mode.
4. Self-clocked mode frequency is the frequency that the PLL operates at when the reference frequency falls below  $f_{LOR}$  with default MFD/RFD settings.
5. This parameter is characterized before qualification rather than 100% tested.
6. Proper PC board layout procedures must be followed to achieve specifications.
7. This specification applies to the period required for the PLL to relock after changing the MFD frequency control bits in the synthesizer control register (SYNCR).
8. Assuming a reference is available at powerup, lock time is measured from the time  $V_{DD}$  and  $V_{SS}$  are valid to  $\overline{RSTOUT}$  negating. If the crystal oscillator is being used as the reference for the PLL, then the crystal start up time must be added to the PLL lock time to determine the total start-up time.
9. PLL is operating in 1:1 PLL mode.
10. Jitter is the average deviation from the programmed frequency measured over the specified interval at maximum  $f_{sys}$ . Measurements are made with the device powered by filtered supplies and clocked by a stable external clock signal. Noise injected into the PLL circuitry via  $V_{DD}$  and  $V_{SS}$  and variation in crystal oscillator frequency increase the  $C_{Jitter}$  percentage for a given interval.

Preliminary

## 23.9 QADC Electrical Characteristics

The QADC electrical characteristics are shown in [Table 23-6](#), [Table 23-7](#), and [Table 23-8](#).

**Table 23-6. QADC Absolute Maximum Ratings**

Parameter	Symbol	Min	Max	Unit
Analog supply, with reference to $V_{SSA}$	$V_{DDA}$	-0.3	6.0	V
Internal digital supply <sup>(1)</sup> with reference to $V_{SS}$	$V_{DD}$	-0.3	4.0	V
Reference supply with reference to $V_{RL}$	$V_{RH}$	-0.3	6.0	V
$V_{SS}$ differential voltage	$V_{SS} - V_{SSA}$	-0.1	0.1	V
$V_{DD}$ differential voltage <sup>(2)</sup>	$V_{DD} - V_{DDA}$	-6.0	4.0	V
$V_{REF}$ differential voltage	$V_{RH} - V_{RL}$	-0.3	6.0	V
$V_{RH}$ to $V_{DDA}$ differential voltage <sup>(2)</sup>	$V_{RH} - V_{DDA}$	-6.0	6.0	V
$V_{RL}$ to $V_{SSA}$ differential voltage	$V_{RL} - V_{SSA}$	-0.3	0.3	V
$V_{DDH}$ to $V_{DDA}$ differential voltage	$V_{DDH} - V_{DDA}$	-1.0	1.0	V
Maximum input current <sup>(3), (4), (5)</sup>	$I_{MA}$	-25	25	mA

1. For internal digital supply of  $V_{DD} = 3.3$  V typical
2. Refers to allowed random sequencing of power supplies
3. Transitions within the limit do not affect device reliability or cause permanent damage. Exceeding limit may cause permanent conversion error on stressed channels and on unstressed channels.
4. Input must be current limited to the value specified. To determine the value of the required current-limiting resistor, calculate resistance values using  $V_{POSCLAMP} = V_{DDA} + 0.3$  V and  $V_{NEGCLAMP} = -0.3$  V, then use the larger of the calculated values.
5. Condition applies to one pin at a time.

**Table 23-7. QADC Electrical Specifications (Operating)**  
 ( $V_{DDH}$  and  $V_{DDA} = 5.0 \text{ Vdc} \pm 0.5 \text{ V}$ ,  $V_{DD} = 2.7$  to  $3.6 \text{ V}$ ,  $V_{SS}$  and  $V_{SSA} = 0 \text{ Vdc}$ ,  
 $f_{QCLK} = 2.0 \text{ MHz}$ ,  $T_A$  within operating temperature range)

Parameter <sup>(1)</sup>	Symbol	Min	Max	Unit
Analog supply	$V_{DDA}$	4.5	5.5	V
$V_{SS}$ differential voltage	$V_{SS} - V_{SSA}$	-100	100	mV
Reference voltage low <sup>(2)</sup>	$V_{RL}$	$V_{SSA}$	$V_{SSA} + 0.1$	V
Reference voltage high <sup>(2)</sup>	$V_{RH}$	$V_{DDA} - 0.1$	$V_{DDA}$	V
$V_{REF}$ differential voltage	$V_{RH} - V_{RL}$	4.5	5.5	V
Input voltage	$V_{INDC}$	$V_{SSA} - 0.3$	$V_{DDA} + 0.3$	V
Input high voltage, PQA and PQB	$V_{IH}$	$0.7 (V_{DDA})$	$V_{DDA} + 0.3$	V
Input low voltage, PQA and PQB	$V_{IL}$	$V_{SSA} - 0.3$	$0.4 (V_{DDA})$	V
Input hysteresis, PQA and PQB <sup>(3)</sup>	$V_{HYS}$	0.5	—	V
Output low voltage, PQA and PQB <sup>(4)</sup> $I_{OL} = 2.0 \text{ mA}$	$V_{OL}$	—	0.8	V
Output high voltage, PQA and PQB <sup>(3)</sup> $I_{OH} = -2.0 \text{ mA}$	$V_{OH}$	$V_{DDH} - 0.8$	—	V
Reference supply current, dc	$I_{ref}$	—	250	$\mu\text{A}$
Reference supply current, transient	$I_{ref}$	—	2	mA
Load capacitance, PQA and PQB	$C_L$	—	50	pF
Input current, channel off <sup>(5)</sup> PQA PQB	$I_{OFF}$	-200 -150	200 150	nA
Total input capacitance <sup>(6)</sup> PQA not sampling PQB not sampling Incremental capacitance added during sampling	$C_{In}$	— — —	15 10 5	pF

- QADC converter specifications are only guaranteed for  $V_{DDH}$  and  $V_{DDA} = 5.0 \text{ V} \pm 0.5 \text{ V}$ .  $V_{DDH}$  and  $V_{DDA}$  may be powered down to 2.7 V with only GPIO functions supported.
- To obtain full-scale, full-range results,  $V_{SSA} \leq V_{RL} \leq V_{INDC} \leq V_{RH} \leq V_{DDA}$
- Parameter applies to these pins:  
 Port A: PQA[7:0]/AN[59:58]/ETRIG[2:1]  
 Port B: PQB[7:0]/AN[3:0]/AN[51:48]/AN[Z:W]
- Full driver (push-pull).
- Maximum leakage occurs at maximum operating temperature. Current decreases by approximately one-half for each 8°C to 12°C, in the ambient temperature range of 50°C to 125°C.
- This parameter is characterized before qualification rather than 100% tested.

**Preliminary Electrical Specifications**

**Table 23-8. QADC Conversion Specifications (Operating)**  
 ( $V_{DDH}$  and  $V_{DDA} = 5.0 \text{ Vdc} \pm 0.5 \text{ V}$ ,  $V_{DD} = 2.7 \text{ to } 3.6 \text{ V}$ ,  $V_{SS}$  and  $V_{SSA} = 0 \text{ Vdc}$ ,  
 $V_{RH} - V_{RL} = 5 \text{ Vdc} \pm 0.5 \text{ V}$ ,  $T_A$  within operating temperature range,  $f_{sys} = 16 \text{ MHz}$ )

Parameter	Symbol	Min	Max	Unit
QADC clock (QCLK) frequency <sup>(1)</sup>	$f_{QCLK}$	0.5	2.1	MHz
Conversion cycles	CC	14	28	QCLK cycles
Conversion time $f_{QCLK} = 2.0 \text{ MHz}^{(1)}$ Min = CCW/IST = %00 Max = CCW/IST = %11	$t_{CONV}$	7.0	14.0	$\mu\text{s}$
Stop mode recovery time	$t_{SR}$	—	10	$\mu\text{s}$
Resolution <sup>(2)</sup>	—	5	—	mV
Absolute (total unadjusted) error <sup>(3), (4), (5), (6)</sup> $f_{QCLK} = 2.0 \text{ MHz}^{(2)}$ Two clock input sample time	AE	-2	2	Counts
Disruptive input injection current <sup>(7), (8), (9)</sup>	$I_{INJ}^{(10)}$	-1	1	mA
Current Coupling Ratio <sup>(11)</sup> PQA PQB	K	— —	$8 \times 10^{-5}$ $8 \times 10^{-5}$	$\mu$
Incremental error due to injection current <sup>(12)</sup> All channels have same $10 \text{ k} < R_S < 100 \text{ k}$ Channel under test has $R_S = 10 \text{ k}$ , $I_{INJ} = I_{INJMAX}, I_{INJMIN}$	$E_{INJ}$	— —	$\pm 1.0$ $\pm 1.0$	$\mu$ Counts Counts
Source impedance at input <sup>(13)</sup>	$R_S$	—	100	k $\Omega$
Incremental capacitance during sampling <sup>(14)</sup>	$C_{SAMP}$	—	5	pF

- Conversion characteristics vary with  $f_{QCLK}$  rate. Reduced conversion accuracy occurs at max  $f_{QCLK}$  rate. Using the QADC pins as GPIO functions during conversions may result in degraded results.
- At  $V_{RH} - V_{RL} = 5.12 \text{ V}$ , one count = 5 mV
- Accuracy tested and guaranteed at  $V_{RH} - V_{RL} = 5.0 \text{ V} \pm 0.5 \text{ V}$
- This parameter is characterized before qualification rather than 100% tested.
- Absolute error includes 1/2 count (~2.5 mV) of inherent quantization error and circuit (differential, integral, and offset) error. Specification assumes that adequate low-pass filtering is present on analog input pins — capacitive filter with 0.01  $\mu\text{F}$  to 0.1  $\mu\text{F}$  capacitor between analog input and analog ground, typical source isolation impedance of 10 k $\Omega$ .
- Input signals with large slew rates or high frequency noise components cannot be converted accurately. These signals may affect the conversion accuracy of other channels.

**Notes continued on next page**

7. Below disruptive current conditions, the channel being stressed has conversion values of \$3FF for analog inputs greater than  $V_{RH}$  and \$000 for values less than  $V_{RL}$ . This assumes that  $V_{RH} \leq V_{DDA}$  and  $V_{RL} \geq V_{SSA}$  due to the presence of the sample amplifier. Other channels are not affected by non-disruptive conditions.
8. Exceeding limit may cause conversion error on stressed channels and on unstressed channels. Transitions within the limit do not affect device reliability or cause permanent damage.
9. Input must be current limited to the value specified. To determine the value of the required current-limiting resistor, calculate resistance values using  $V_{POSCLAMP} = V_{DDA} + 0.5V$  and  $V_{NEGCLAMP} = -0.3V$ , then use the larger of the calculated values.
10. Condition applies to two adjacent pins.
11. Current coupling ratio,  $K$ , is defined as the ratio of the output current,  $I_{Out}$ , measured on the pin under test to the injection current,  $I_{inj}$ , when both adjacent pins are overstressed with the specified injection current.  $K = I_{Out} / I_{inj}$ . The input voltage error on the channel under test is calculated as  $V_{err} = I_{inj} * K * R_S$ .
12. Performance expected with production silicon.
13. Maximum source impedance is application-dependent. Error resulting from pin leakage depends on junction leakage into the pin and on leakage due to charge-sharing with internal capacitance.  
 Error from junction leakage is a function of external source impedance and input leakage current. In this expression, expected error in result value due to junction leakage is expressed in voltage ( $V_{errj}$ ):

$$V_{errj} = R_S * I_{OFF}$$

where  $I_{OFF}$  is a function of operating temperature.

Charge-sharing leakage is a function of input source impedance, conversion rate, change in voltage between successive conversions, and the size of the filtering capacitor used. Error levels are best determined empirically. In general, continuous conversion of the same channel may not be compatible with high source impedance.

14. For a maximum sampling error of the input voltage  $\leq 1$  LSB, then the external filter capacitor,  $C_f \geq 1024 * C_{smp}$ . The value of  $C_{smp}$  in the new design may be reduced.

Preliminary

## 23.10 FLASH Memory Characteristics

The FLASH memory characteristics are shown in [Table 23-9](#) and [Table 23-10](#).

**Table 23-9. SGFM FLASH Program and Erase Characteristics**  
( $V_{DDF} = 2.7$  to  $3.6$  V,  $T_A = T_L$  to  $T_H$ )<sup>(1)</sup>

Parameter	Symbol	Min	Typ	Max	Unit
System clock (read only)	$f_{sys(R)}$	0	—	33	MHz
System clock (program/erase)	$f_{sys(P/E)}$	0.15	—	33	MHz
FLASH statemachine clock	$f_{CLK}$	150	—	200	kHz

1.  $T_L$  is defined to be  $-40^\circ\text{C}$  and  $T_H$  is defined to be  $85^\circ\text{C}$

**Table 23-10. SGFM FLASH Module Life Characteristics**  
( $V_{DDF} = 2.7$  to  $3.6$  V,  $T_A = T_L$  to  $T_H$ )

Parameter	Symbol	Value	Unit
Maximum number of guaranteed program/erase cycles <sup>(1)</sup> before failure	P/E	1,000 <sup>(2)</sup>	Cycles
Data retention at average operating temperature of $85^\circ\text{C}$	Retention	10	Years

1. A program/erase cycle is defined as switching the bits from  $1 \rightarrow 0 \rightarrow 1$ .
2. Reprogramming of a FLASH array block prior to erase is not required.



**23.11 External Interface Timing Characteristics**
**Table 23-11. External Interface Timing Characteristics**  
 ( $V_{DD} = 2.7\text{ V to }3.6\text{ V}$ ,  $V_{SS} = 0\text{ V}$ ,  $T_A = T_L\text{ to }T_H$ )

No.	Characteristic <sup>(1), (2)</sup>	Symbol	Min	Max	Unit
1	CLKOUT period	$t_{cyc}$	30	—	ns
2	CLKOUT low pulse width	$t_{CLW}$	$0.5 t_{cyc} - 1$	—	ns
3	CLKOUT high pulse width	$t_{CHW}$	$0.5 t_{cyc} - 1$	—	ns
4	All rise times	$t_{CR}$	—	3	ns
5	All fall times	$t_{CF}$	—	3	ns
6	CLKOUT high to A[22:0], TSIZ[1:0] valid <sup>(3)</sup>	$t_{CHAV}$	—	7	ns
7	CLKOUT high to A[22:0], TSIZ[1:0] invalid	$t_{CHAI}$	0	—	ns
8	CLKOUT high to $\overline{CS}[3:0]$ asserted <sup>(3)</sup>	$t_{CHCA}$	—	7	ns
9	CLKOUT high to $\overline{CS}[3:0]$ negated	$t_{CHCN}$	0	—	ns
10	CLKOUT high to CSE[1:0] valid	$t_{CHCEV}$	—	7	ns
11	CLKOUT high to CSE[1:0] invalid	$t_{CHCEI}$	0	—	ns
12	CLKOUT high to TC[2:0], PSTAT[3:0] valid	$t_{CHTV}$	—	12	ns
13	CLKOUT high to TC[2:0], PSTAT[3:0] invalid	$t_{CHTI}$	0	—	ns
14	CLKOUT high to $R/\overline{W}$ high hold time	$t_{CHRWH}$	0	10	ns
15	CLKOUT high to $R/\overline{W}$ valid write	$t_{CHRWV}$	$0.25 t_{cyc}$	$0.25 t_{cyc} + 6$	ns
16	CLKOUT high to $\overline{OE}$ , $\overline{EB}$ asserted <sup>(3), (4), (5)</sup>	$t_{CHOEA}$	$0.25 t_{cyc}$	$0.25 t_{cyc} + 8$	ns
17	CLKOUT high to $\overline{OE}$ , $\overline{EB}$ read negated	$t_{CHOEN}$	0	6	ns
17A	CLKOUT low to $\overline{EB}$ write negated <sup>(4)</sup>	$t_{CLEN}$	$0.25 t_{cyc}$	$0.25 t_{cyc} + 6$	ns
18	CLKOUT low to $\overline{SHS}$ low	$t_{CLSL}$	0	7	ns
19	CLKOUT high to $\overline{SHS}$ high <sup>(6)</sup>	$t_{CHSH}$	0	7	ns
20	CLKOUT low to data-out low impedance write/show	$t_{CHDOD}$	0	—	ns
21	CLKOUT high to data-out high impedance write/show <sup>(4), (6), (7)</sup>	$t_{CHDOZ}$	2	10	ns
22	CLKOUT low to data-out valid write	$t_{CLDOVW}$	—	8	ns
22A	CLKOUT low to data-out valid show <sup>(8)</sup>	$t_{CLDOVS}$	—	15	ns

Continued on next page

Preliminary Electrical Specifications

**Table 23-11. External Interface Timing Characteristics (Continued)**  
 ( $V_{DD} = 2.7\text{ V to }3.6\text{ V}$ ,  $V_{SS} = 0\text{ V}$ ,  $T_A = T_L\text{ to }T_H$ )

No.	Characteristic <sup>(1), (2)</sup>	Symbol	Min	Max	Unit
23	CLKOUT high to data-out invalid write/show <sup>(6), (7)</sup>	$t_{CHDOIW}$	2	—	ns
24	Data-in valid to CLKOUT high read	$t_{DIVCH}$	17	—	ns
25	CLKOUT high to data-in invalid read	$t_{CHDII}$	0	—	ns
26	$\overline{TA}$ , $\overline{TEA}$ asserted to CLKOUT high	$t_{TACH}$	$0.25 t_{cyc} + 9$	—	ns
27	CLKOUT high to $\overline{TA}$ , $\overline{TEA}$ negated	$t_{CHTN}$	0	—	ns

1. All AC timing is shown with respect to 50%  $V_{DD}$  levels, unless otherwise noted.
2. Timing is not guaranteed during the clock cycle of mode and/or setup changes (for example, changing pin function between GPIO and primary function, changing GPIO between input/output functions, changing control registers that affect pin functions).
3.  $A[22:0]$ ,  $TSIZ[1:0]$ ,  $\overline{CS}[3:0]$  valid to  $R/\overline{W}$  (write),  $\overline{OE}$ ,  $\overline{EB}$  asserted (minimum) spec is 0 ns. This parameter is characterized before qualification rather than 100% tested.
4. Write/show data high-Z to  $\overline{OE}$  asserted (minimum) or from  $\overline{EB}$  negated (write — maximum) spec is 0 ns. This parameter is characterized before qualification rather than 100% tested.
5. To prevent an unintentional assertion glitch of the  $\overline{EB}$  pins during a synchronous reset (and before the reset overrides configure the chip in a stable mode), leave the port output data register bits associated with the  $\overline{EB}$  GPO default of 1 and do not pull the pins down with a current load.
6.  $\overline{SHS}$  high to show data or write data invalid (minimum) spec is 0 ns. This parameter is characterized before qualification rather than 100% tested.
7. Write/show data high-Z and write/show data invalid is 0 ns for synchronous reset conditions.
8.  $t_{CLDOVS}$  value reflects maximum specification for any bus cycle. For non-FLASH read cycles,  $t_{CLDOVS}$  is specified at 8 ns maximum.

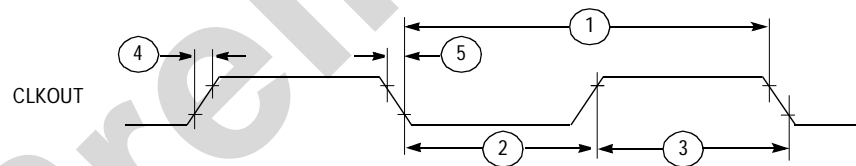

**Figure 23-1. CLKOUT Timing**

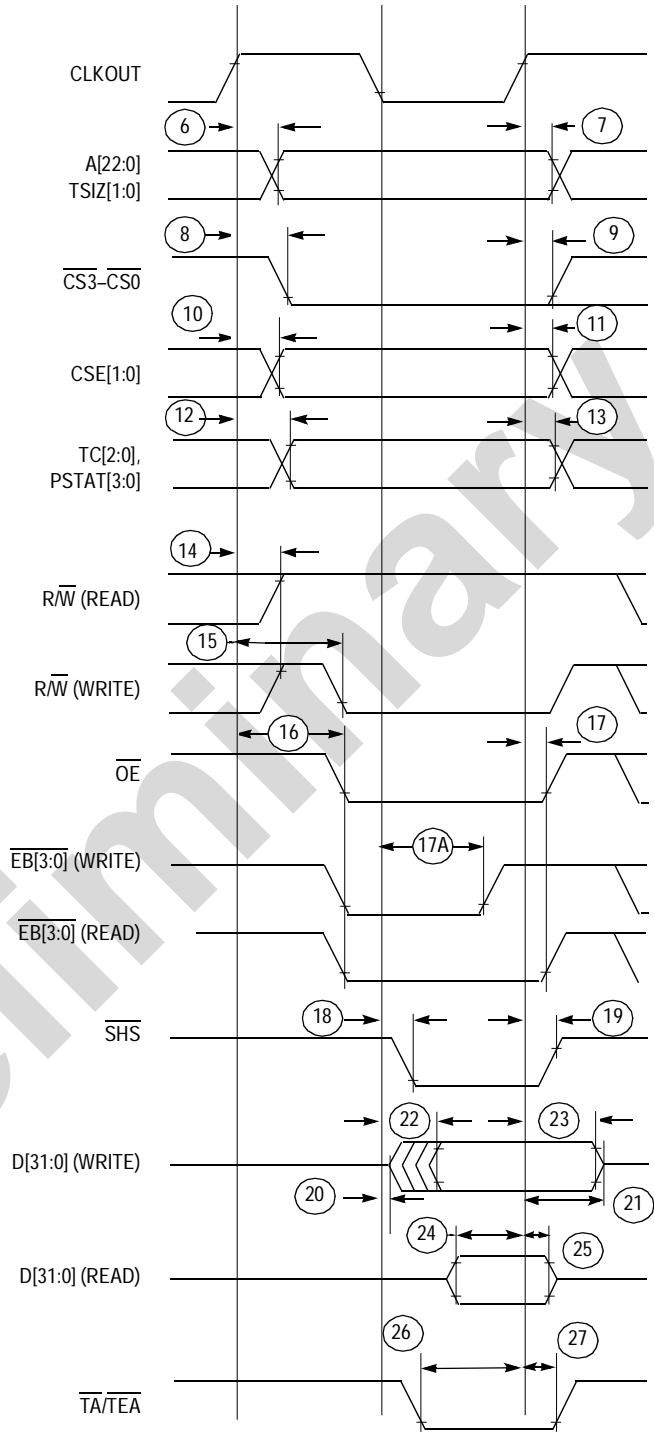
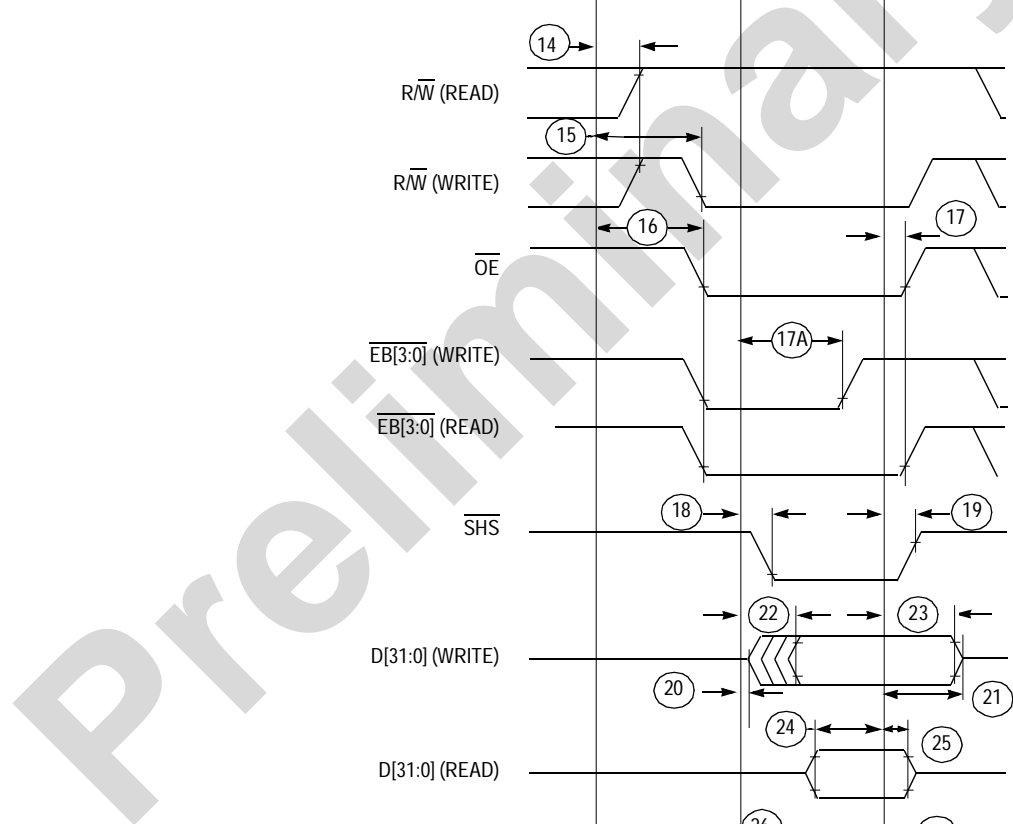

**Figure 23-2. Clock Read/Write Cycle Timing**

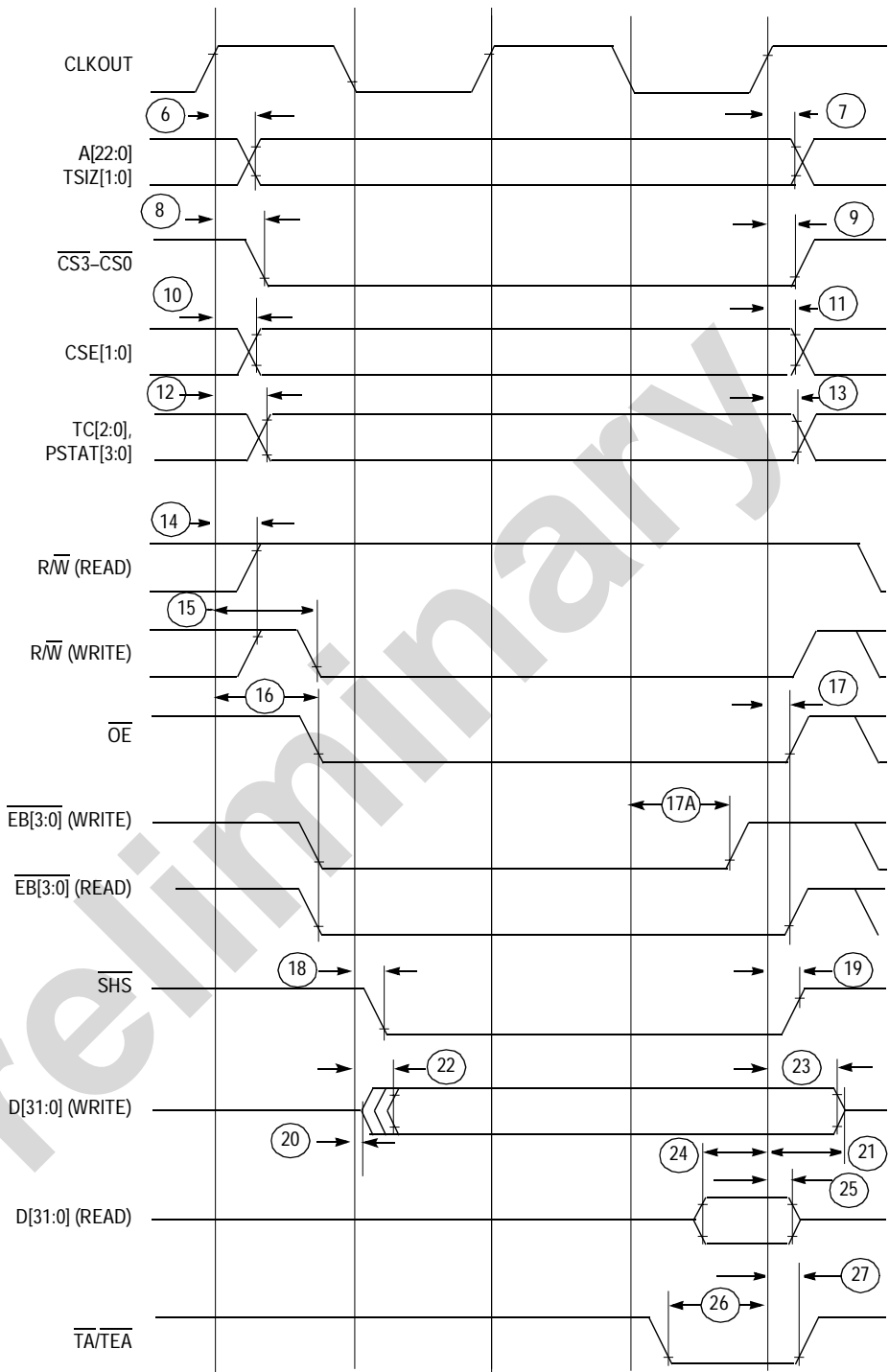
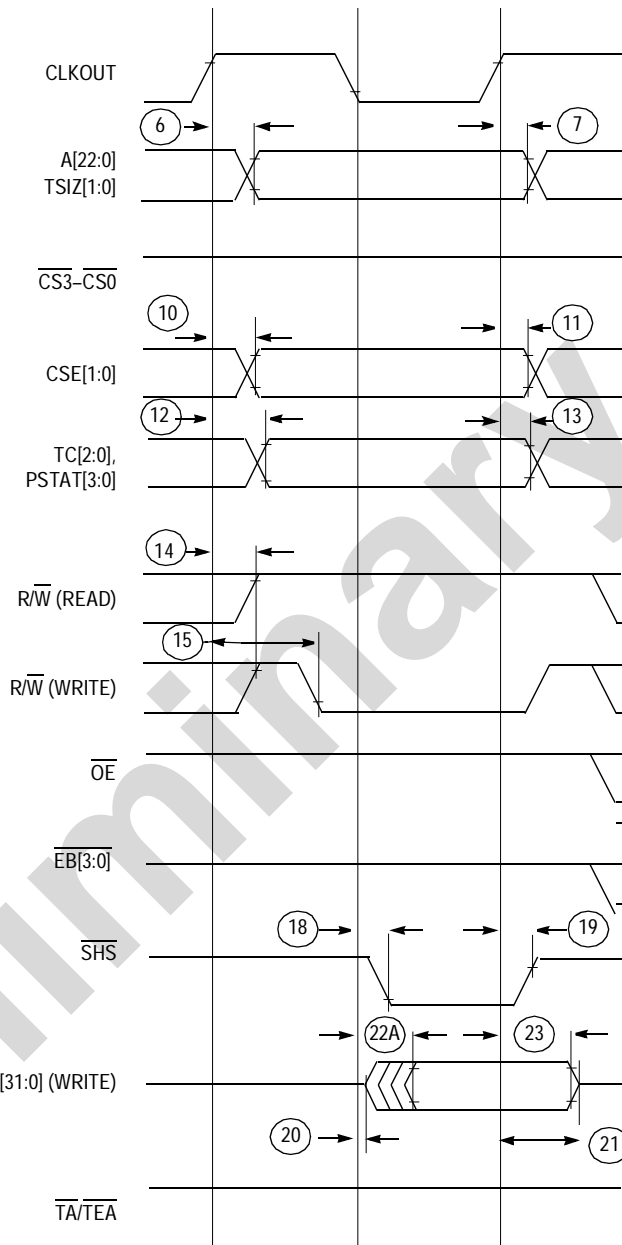

Figure 23-3. Read/Write Cycle Timing with Wait States



**Figure 23-4. Show Cycle Timing**

**23.12 General Purpose I/O Timing**

**Table 23-12. GPIO Timing<sup>(1)</sup>**  
**( $V_{DD} = 2.7$  to  $3.6$  V,  $V_{SS} = 0$  V,  $T_A = T_L$  to  $T_H$ )<sup>(2)</sup>**

No.	Characteristic	Symbol	Min	Max	Unit
G1	CLKOUT high to GPIO output valid	$t_{CHPOV}$	—	20	ns
G2	CLKOUT high to GPIO output invalid	$t_{CHPOI}$	0	—	ns
G3	GPIO input valid to CLKOUT high	$t_{PVCH}$	10	—	ns
G4	CLKOUT high to GPIO input invalid	$t_{CHPI}$	2	—	ns
GA1	CLKOUT high to PQA output valid	$t_{CHPAOV}$	—	20	ns
GA2	CLKOUT high to PQA output invalid	$t_{CHPAOI}$	0	—	ns
GA3	PQA/PQB input valid to CLKOUT low	$t_{PAVCH}$	10	—	ns
GA3	CLKOUT low to PQA/PQB input invalid	$t_{CHPAI}$	2	—	ns

- GPIO pins include: Ports A–I, edge port (including  $\overline{INT}$  functions), SPI, SCI1, and SCI2 (including SCI functions), and timer 1 and timer 2 (including timer functions).
- All AC timing is shown with respect to 50%  $V_{DD}$  levels unless otherwise noted.

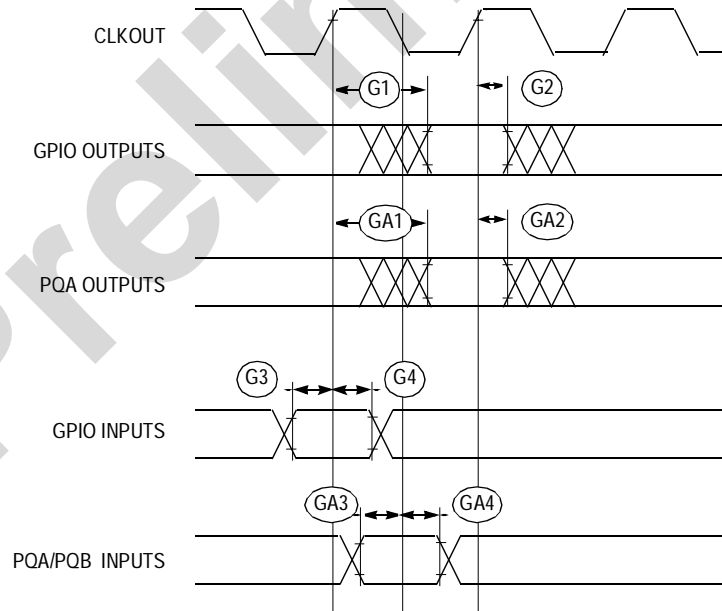

**Figure 23-5. GPIO Timing**

### 23.13 Reset and Configuration Override Timing

**Table 23-13. Reset and Configuration Override Timing**  
( $V_{DD} = 2.7$  to  $3.6$  V,  $V_{SS} = 0$  V,  $T_A = T_L$  to  $T_H$ )

No.	Parameter <sup>(1)</sup>	Symbol	Min	Max	Unit
R1	$\overline{\text{RESET}}$ input asserted to CLKOUT high	$t_{\text{RACH}}$	10	—	ns
R2	CLKOUT high to $\overline{\text{RESET}}$ input negated	$t_{\text{CHRN}}$	2	—	ns
R3	$\overline{\text{RESET}}$ input assertion time <sup>(2)</sup>	$t_{\text{RIAT}}$	5	—	$t_{\text{cyc}}$
R4	CLKOUT high to $\overline{\text{RSTOUT}}$ valid <sup>(3)</sup>	$t_{\text{CHROV}}$	—	20	ns
R5	$\overline{\text{RSTOUT}}$ asserted to configuration overrides asserted	$t_{\text{ROACA}}$	0	—	ns
R6	Configuration override setup time to $\overline{\text{RSTOUT}}$ negated	$t_{\text{COS}}$	20	—	$t_{\text{cyc}}$
R7	Configuration override hold time after $\overline{\text{RSTOUT}}$ negated	$t_{\text{COH}}$	0	—	ns
R8	$\overline{\text{RSTOUT}}$ negated to configuration override high impedance	$t_{\text{RONCZ}}$	—	1	$t_{\text{cyc}}$

1. All AC timing is shown with respect to 50%  $V_{DD}$  levels, unless otherwise noted.
2. During low-power STOP, the synchronizers for the  $\overline{\text{RESET}}$  input are bypassed and  $\overline{\text{RESET}}$  is asserted asynchronously to the system. Thus,  $\overline{\text{RESET}}$  must be held a minimum of 100 ns.
3. This parameter also covers the timing of the show interrupt function.

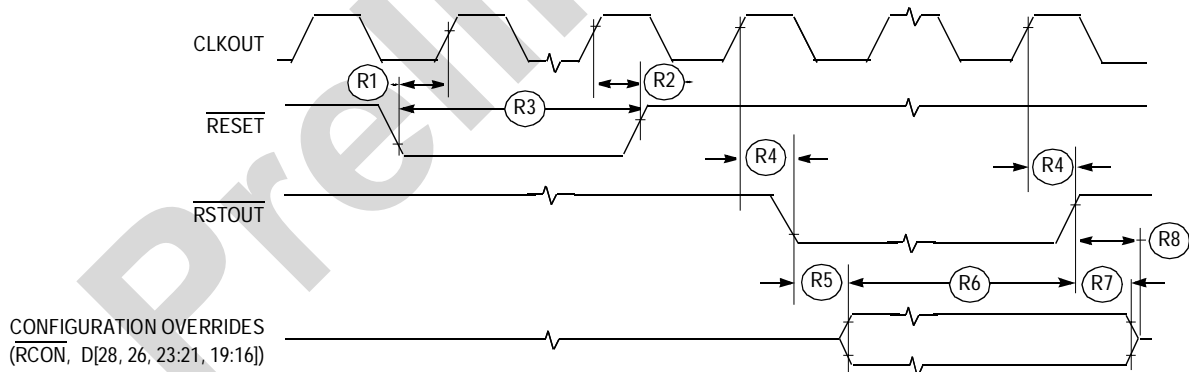

**Figure 23-6.  $\overline{\text{RESET}}$  and Configuration Override Timing**

**Preliminary Electrical Specifications**
**23.14 SPI Timing Characteristics**
**Table 23-14. SPI Timing Characteristics**  
 ( $V_{DD} = 2.7$  to  $3.6$  V,  $V_{SS} = 0$  V,  $T_A = T_L$  to  $T_H$ )

No.	Function <sup>(1)</sup>	Symbol	Min	Max	Unit
—	Operating frequency Master Slave	$f_{op}$	DC DC	$1/2 \times f_{sys}$ $1/2 \times f_{sys}$	System frequency
1	SCK period Master Slave	$t_{SCK}$	2 2	2048 —	$t_{cyc}$ $t_{cyc}$
2	Enable lead time Master Slave	$t_{Lead}$	1/2 1	— —	$t_{sck}$ $t_{cyc}$
3	Enable lag time Master Slave	$t_{Lag}$	1/2 1	— —	$t_{sck}$ $t_{cyc}$
4	Clock (SCK) high or low time Master Slave	$t_{WSCK}$	$t_{cyc} - 30$ $t_{cyc} - 30$	$1024 t_{cyc}$ —	ns
5	Data setup time, inputs Master Slave	$t_{SU}$	25 25	— —	ns
6	Data hold time, inputs Master Slave	$t_{High}$	0 25	— —	ns
7	Slave access time	$t_A$	—	1	$t_{cyc}$
8	Slave MISO disable time	$t_{DIS}$	—	1	$t_{cyc}$
9	Data valid after SCK edge Master Slave	$t_V$	— —	25 25	ns
10	Data hold time, outputs Master Slave	$t_{Hold}$	0 0	— —	ns
11	Rise time Input Output	$t_{RI}$ $t_{RO}$	— —	$t_{cyc} - 25$ 25	ns
12	Fall time Input Output	$t_{FI}$ $t_{FO}$	— —	$t_{cyc} - 25$ 25	ns

1. All ac timing is shown with respect to 50%  $V_{DD}$  unless otherwise noted. Timing is based on wired-OR mode being off. With wired-OR mode on, timing will depend on pullup value.



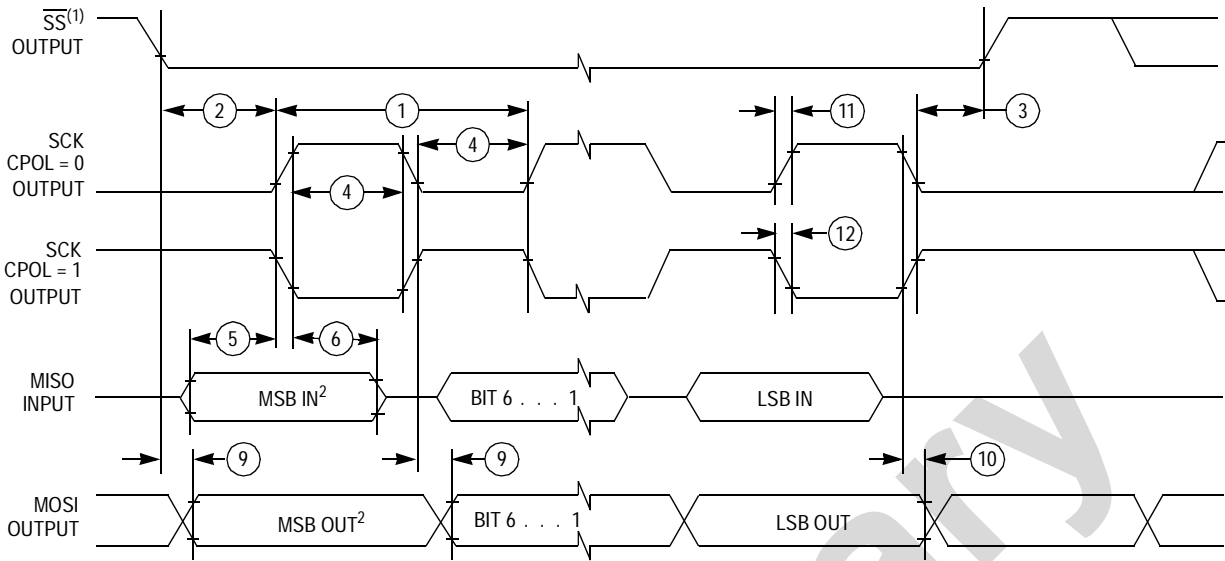

Notes:

1.  $\overline{SS}$  output mode (DDS7 = 1, SSOE = 1)
2. LSBF = 0. For LSBF = 1, bit order is LSB, bit 1, ..., bit 6, MSB.

**A) SPI Master Timing (CPHA = 0)**

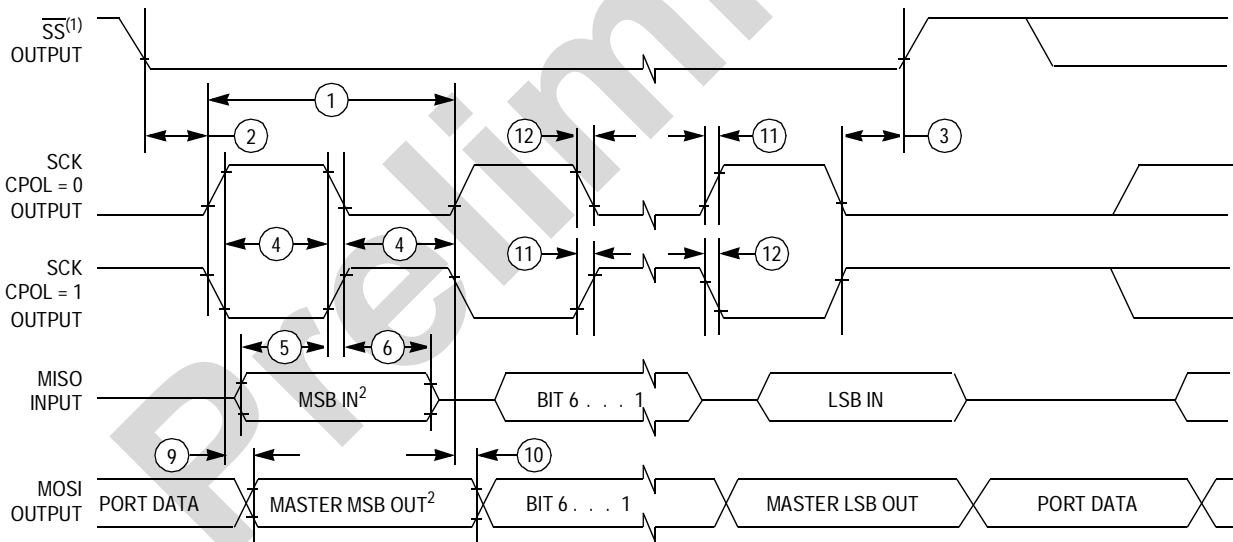

Notes:

1.  $\overline{SS}$  output mode (DDS7 = 1, SSOE = 1)
2. LSBF = 0. For LSBF = 1, bit order is LSB, bit 1, ..., bit 6, MSB.

**B) SPI Master Timing (CPHA = 1)**

**Figure 23-7. SPI Timing Diagram (Sheet 1 of 2)**

Preliminary Electrical Specifications

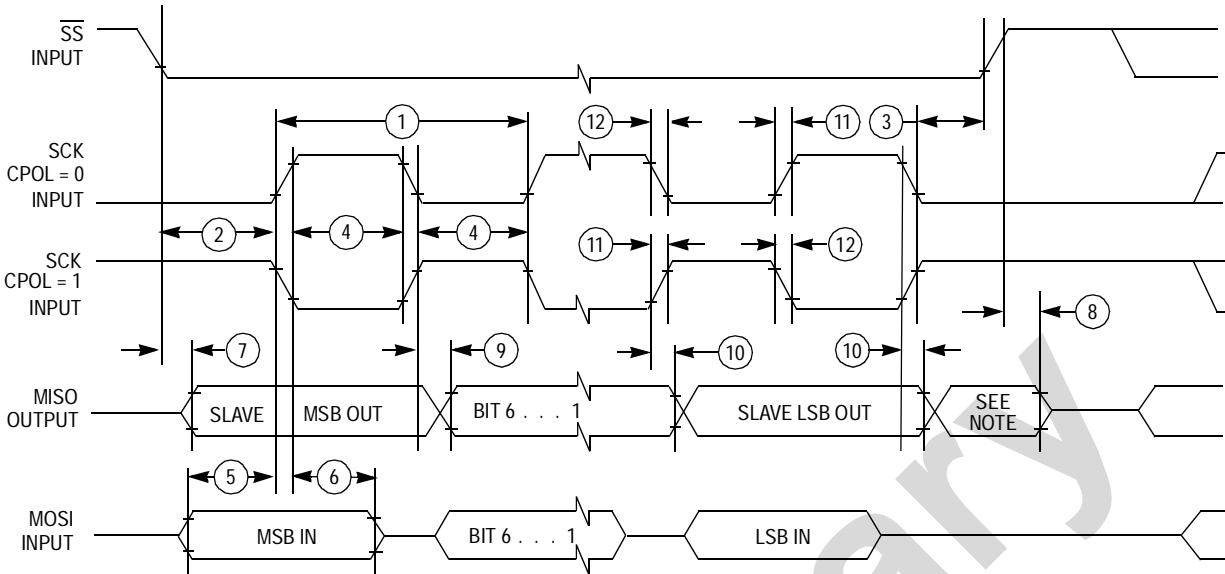

Note: Not defined, but normally MSB of character just received

A) SPI Slave Timing (CPHA = 0)

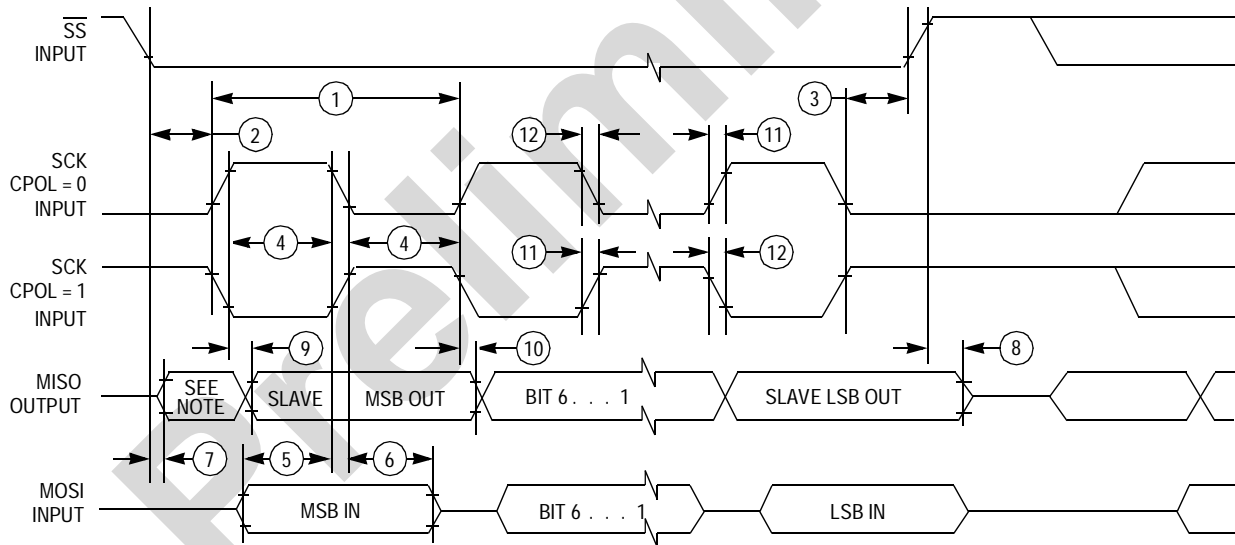

Note: Not defined, but normally LSB of character just received

B) SPI Slave Timing (CPHA = 1)

Figure 24-7. SPI Timing Diagram (Sheet 2 of 2)

### 23.15 OnCE, JTAG, and Boundary Scan Timing

**Table 23-15. OnCE, JTAG, and Boundary Scan Timing**  
( $V_{DD} = 2.7$  to  $3.6$  V,  $V_{SS} = 0$  V,  $T_A = T_L$  to  $T_H$ )

No.	Characteristics	Symbol	Min	Max	Unit
1	TCLK frequency of operation	$f_{JCYC}$	dc	$1/2 \times f_{sys}$	MHz
2	TCLK cycle period	$t_{JCYC}$	2	—	$t_{cyc}$
3	TCLK clock pulse width	$t_{JCW}$	25	—	ns
4	TCLK rise and fall times	$t_{JCRF}$	0	3	ns
5	Boundary scan input data setup time to TCLK rise	$t_{BSDST}$	5	—	ns
6	Boundary scan input data hold time after TCLK rise	$t_{BSDHT}$	24	—	ns
7	TCLK low-to-boundary scan output data valid	$t_{BSDV}$	0	40	ns
8	TCLK low-to-boundary scan output high Z	$t_{BSDZ}$	0	40	ns
9	TMS, TDI, and $\overline{DE}$ input data setup time to TCLK rise <sup>(1)</sup>	$t_{TAPDST}$	7	—	ns
10	TMS, TDI, and $\overline{DE}$ input data hold time after TCLK rise <sup>(1)</sup>	$t_{TAPDHT}$	15	—	ns
11	TCLK low to TDO data valid	$t_{TDODV}$	0	25	ns
12	TCLK low to TDO high Z	$t_{TDODZ}$	0	9	ns
13	$\overline{TRST}$ assert time	$t_{TRSTAT}$	100	—	ns
14	$\overline{TRST}$ setup time (negation) to TCLK high	$t_{TRSTST}$	10	—	ns
15	$\overline{DE}$ input data setup time to CLKOUT rise <sup>(1)</sup>	$t_{DEDST}$	10	—	ns
16	$\overline{DE}$ input data hold time after CLKOUT rise <sup>(1)</sup>	$t_{DEDHT}$	2	—	ns
17	CLKOUT high to $\overline{DE}$ data valid	$t_{DEDV}$	0	20	ns
18	CLKOUT high to $\overline{DE}$ high Z	$t_{DEDZ}$	0	10	ns

1. Parameters 9 and 10 apply to the  $\overline{DE}$  pin when used to enable OnCE. Parameters 15 and 16 apply to the  $\overline{DE}$  pin when used to request the processor to enter debug mode.

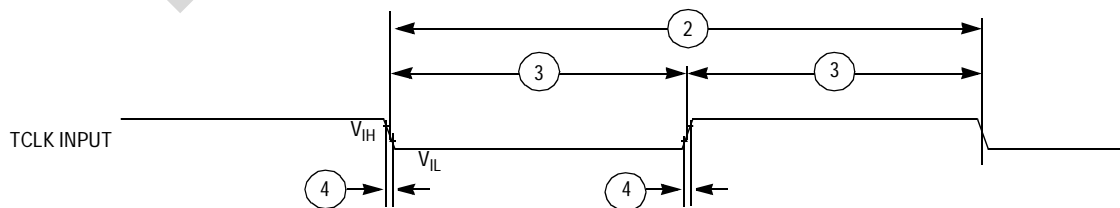

**Figure 23-8. Test Clock Input Timing**

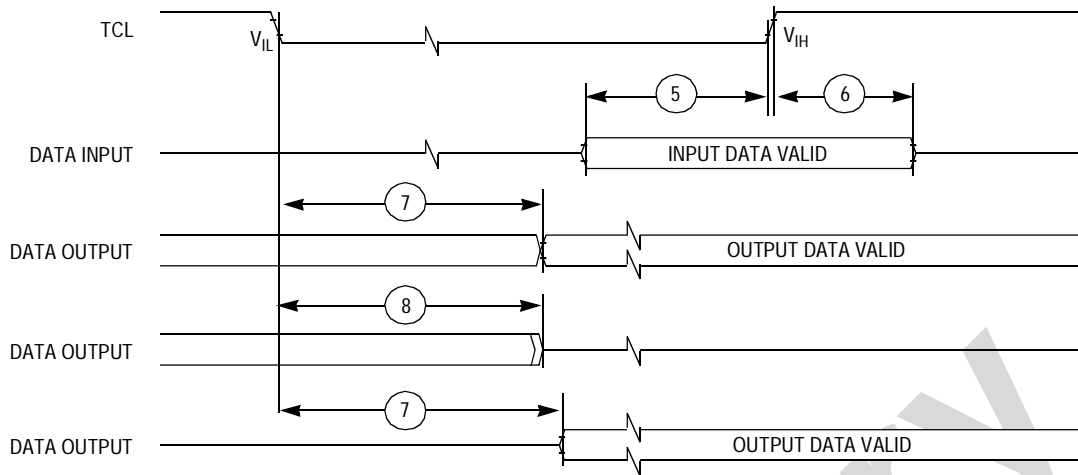

Figure 23-9. Boundary Scan (JTAG) Timing

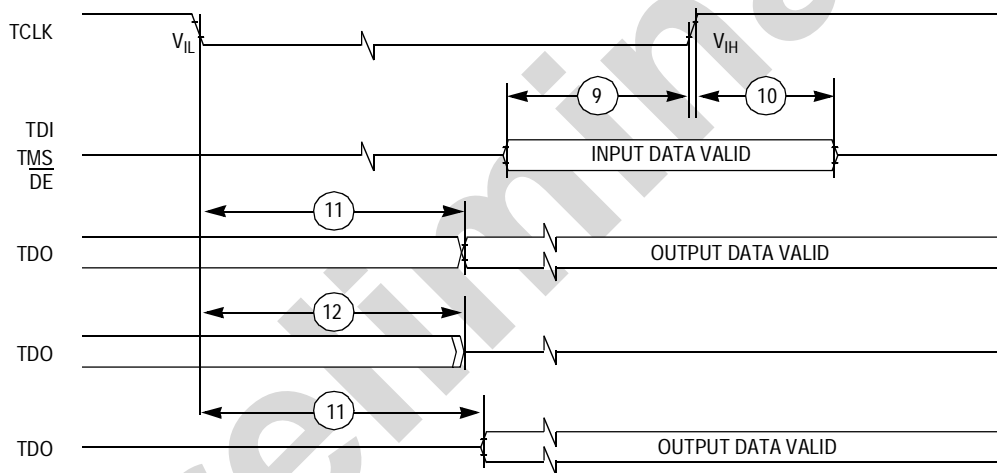

Figure 23-10. Test Access Port Timing

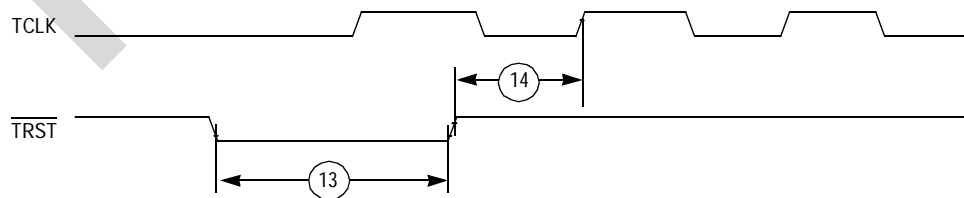
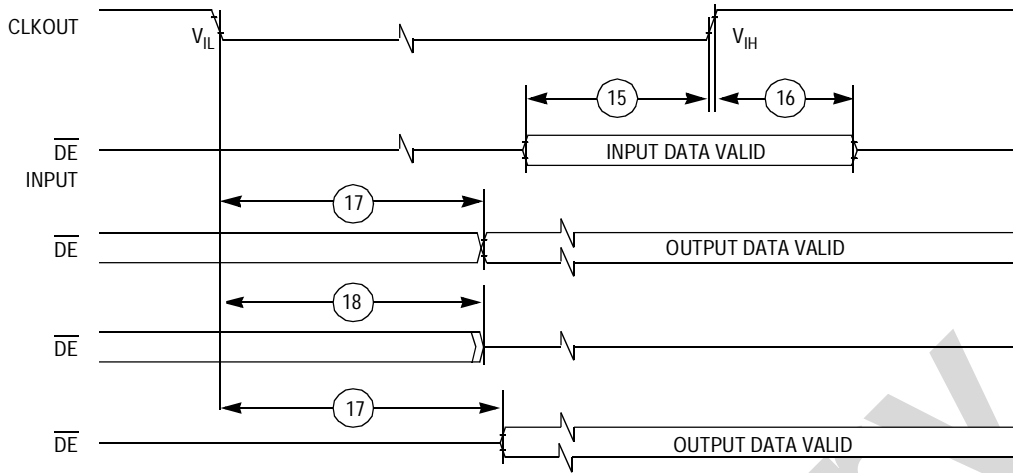

Figure 23-11.  $\overline{TRST}$  Timing



**Figure 23-12. Debug Event Pin Timing**

Preliminary

Freescale Semiconductor, Inc.



Preliminary

## Section 24. Mechanical Specifications

### 24.1 Contents

24.2	Introduction . . . . .	639
24.3	Bond Pins . . . . .	640
24.4	Package Information for the 144-Pin LQFP . . . . .	641
24.5	Package Information for the 100-Pin LQFP . . . . .	641
24.6	Package Information for the 196-Ball MAPBGA . . . . .	642
24.7	144-Pin LQFP Mechanical Drawing . . . . .	643
24.8	100-Pin LQFP Mechanical Drawing . . . . .	644
24.9	196-Ball MAPBGA Mechanical Drawing . . . . .	645

### 24.2 Introduction

The MMC2114, MMC2113, and MMC2112 are available in three types of packages:

1. 100-pin low-profile quad flat pack (LQFP) version supporting single-chip mode of operation
2. 144-pin LQFP version supporting:
  - Single-chip operation with extra general-purpose input/output
  - Expanded master mode for interfacing to external memories
  - Emulation mode for development and debug
3. 196-ball mold array process ball grid array (MAPBGA) version supporting:
  - Single-chip operation with extra general-purpose input/output
  - Expanded master mode for interfacing to external memories
  - Emulation mode for development and debug

This section shows the latest package specifications available at the time of this publication. To make sure that you have the latest information, contact one of the following:

- Local Motorola Sales Office
- World Wide Web at <http://www.motorola.com/semiconductors/>

Follow the World Wide Web on-line instructions to retrieve the current mechanical specifications.

### 24.3 Bond Pins

The die has a total of 144 bond pads. Of these, the pads that are not bonded out in the 100-pin package are distributed around the circumference of the die. This optional group of pins includes:

A[22:0]

$\overline{R/W}$

$\overline{EB[3:0]}$

CSE[1:0]

TC[2:0]

$\overline{OE}$

$\overline{CS[3:0]}$

3 x  $V_{DD}$

3 x  $V_{SS}$

For more detailed information, see [Section 3. Signal Description](#).



## 24.4 Package Information for the 144-Pin LQFP

The production 144-pin package characteristics are:

- Joint-Electron Device Engineering Council (JEDEC) standard
- Low-profile quad flat pack (LQFP)
- Dimension: 20 x 20 mm
- Lead pitch: 0.5 mm
- Thin: 1.4 mm
- Case number: 918-03
- Clam shell socket: Yamaichi part #IC51-1444-1354
- Open face socket: Yamaichi part #IC201-1444-034

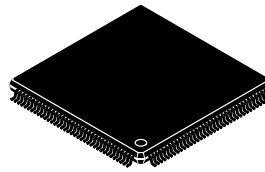

## 24.5 Package Information for the 100-Pin LQFP

The production 100-pin package characteristics are:

- JEDEC standard
- Low-profile quad flat pack (LQFP)
- Dimension: 14 x 14 mm
- Lead pitch: 0.5 mm
- Thin: 1.4 mm
- Case number: 983-02
- Clam shell socket: Yamaichi part #IC51-1004-809
- Open face socket: Yamaichi part #IC201-1004-008

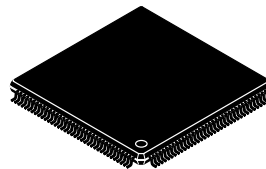

## 24.6 Package Information for the 196-Ball MAPBGA

The production 196-pin package characteristics are:

- JEDEC standard
- 196-ball plastic mold array process ball grid array (MAPBGA)
- Dimension: 15 x 15
- Ball pitch: 1 mm
- Thickness: 1.6 mm
- Case number: 1128C-02

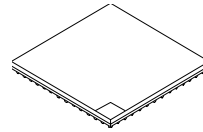

24.7 144-Pin LQFP Mechanical Drawing

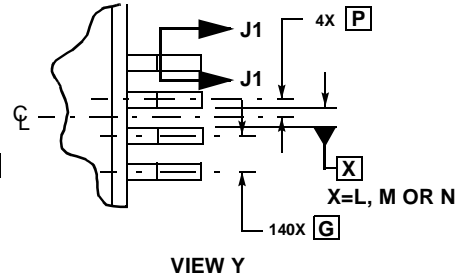
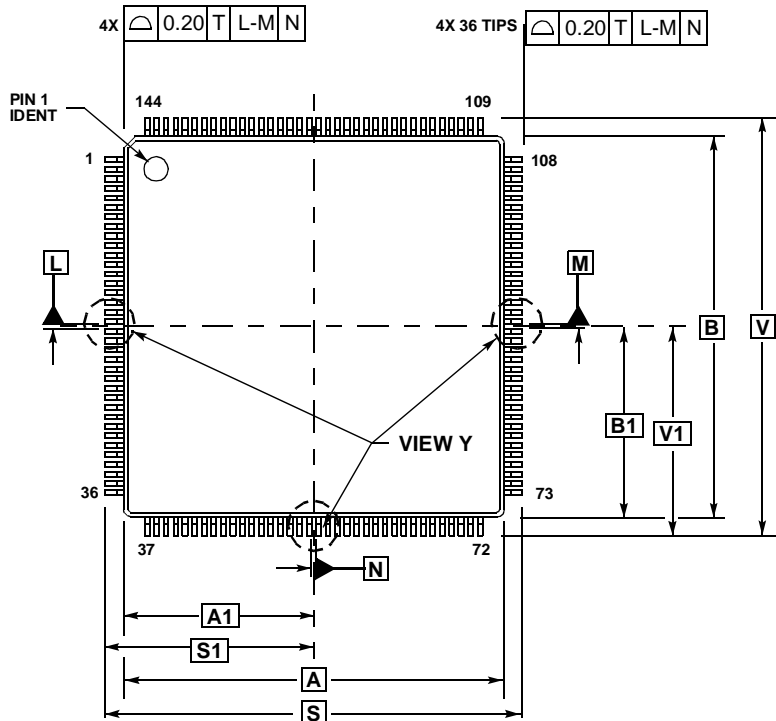

NOTES:

1. DIMENSIONS AND TOLERANCING PER ASME Y14.5M, 1994.
2. DIMENSIONS IN MILLIMETERS.
3. DATUMS L, M, N TO BE DETERMINED AT THE SEATING PLANE, DATUM T.
4. DIMENSIONS S AND V TO BE DETERMINED AT SEATING PLANE, DATUM T.
5. DIMENSIONS A AND B DO NOT INCLUDE MOLD PROTRUSION. ALLOWABLE PROTRUSION IS 0.25 PER SIDE. DIMENSIONS A AND B DO INCLUDE MOLD MISMATCH AND ARE DETERMINED AT DATUM PLANE H.
6. DIMENSION D DOES NOT INCLUDE DAMBAR PROTRUSION. ALLOWABLE DAMBAR PROTRUSION SHALL NOT CAUSE THE D DIMENSION TO EXCEED 0.35.

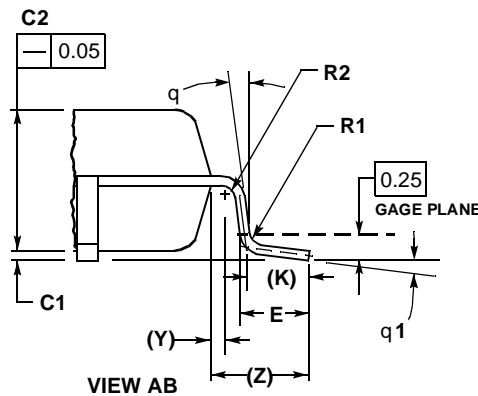
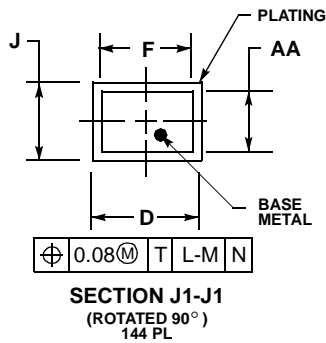
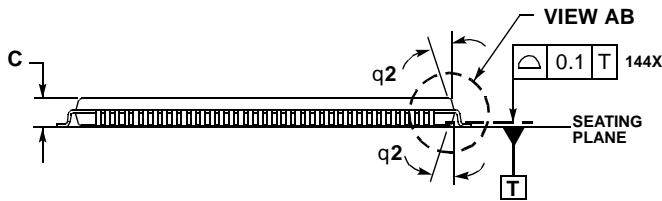

DIM	MILLIMETERS	
	MIN	MAX
A	20.00	BSC
A1	10.00	BSC
B	20.00	BSC
B1	10.00	BSC
C	1.40	1.60
C1	0.05	0.15
C2	1.35	1.45
D	0.17	0.27
E	0.45	0.75
F	0.17	0.23
G	0.50	BSC
J	0.09	0.20
K	0.50	REF
P	0.25	BSC
R1	0.13	0.20
R2	0.13	0.20
S	22.00	BSC
S1	11.00	BSC
V	22.00	BSC
V1	11.00	BSC
Y	0.25	REF
Z	1.00	REF
AA	0.09	0.16
q	0°	
q1	0°	7°
q2	11°	13°

Mechanical Specifications

24.8 100-Pin LQFP Mechanical Drawing

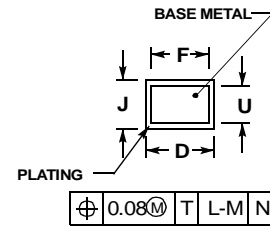
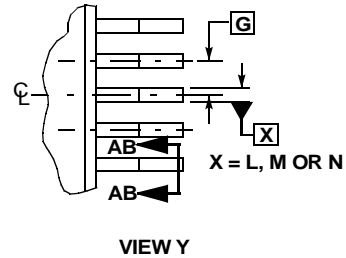
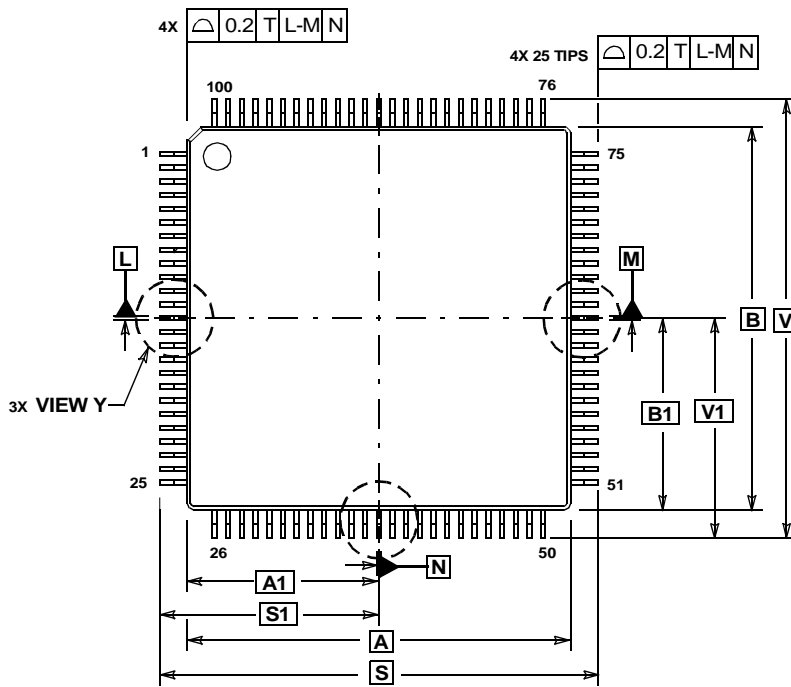

NOTES:

1. DIMENSIONS AND TOLERANCES PER ASME Y14.5M, 1994.
2. DIMENSIONS IN MILLIMETERS.
3. DATUMS L, M AND N TO BE DETERMINED AT THE SEATING PLANE, DATUM T.
4. DIMENSIONS S AND V TO BE DETERMINED AT SEATING PLANE, DATUM T.
5. DIMENSIONS A AND B DO NOT INCLUDE MOLD PROTRUSION. ALLOWABLE PROTRUSION IS 0.25 PER SIDE. DIMENSIONS A AND B INCLUDE MOLD MISMATCH.
6. DIMENSION D DOES NOT INCLUDE DAMBAR PROTRUSION. DAMBAR PROTRUSION SHALL NOT CAUSE THE LEAD WIDTH TO EXCEED 0.35. MINIMUM SPACE BETWEEN PROTRUSION AND ADJACENT LEAD OR PROTRUSION 0.07.

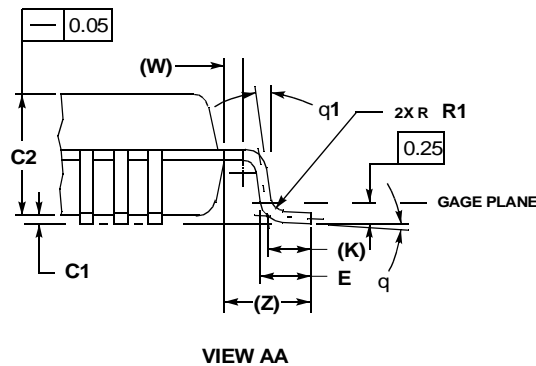
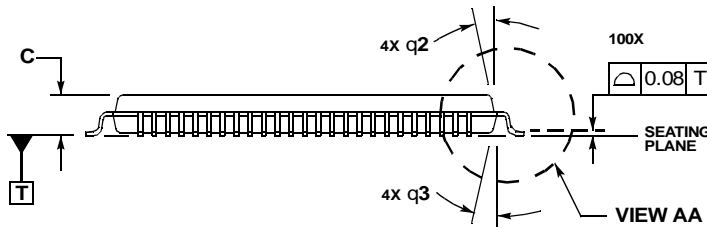

MILLIMETERS		
DIM	MIN	MAX
A	14.00	BSC
A1	7.00	BSC
B	14.00	BSC
B1	7.00	BSC
C	---	1.70
C1	0.05	0.20
C2	1.30	1.50
D	0.10	0.30
E	0.45	0.75
F	0.15	0.23
G	0.50	BSC
J	0.07	0.20
K	0.50	REF
R1	0.08	0.20
S	16.00	BSC
S1	8.00	BSC
U	0.09	0.16
V	16.00	BSC
V1	8.00	BSC
W	0.20	REF
Z	1.00	REF
q	0°	7°
q1	0°	---
q2	12°	REF
q3	12°	REF

### 24.9 196-Ball MAPBGA Mechanical Drawing

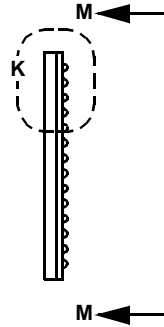
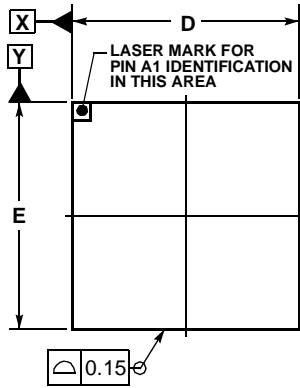

- NOTES:
1. DIMENSIONS ARE IN MILLIMETERS.
  2. INTERPRET DIMENSIONS INND TOLERANCES PER ASME Y14.5M, 1994.
- $\triangle 3$ . DIMENSION  $b$  IS MEASURED AT THE MAXIMUM SOLDER BALL DIAMETER, PARALLEL TO DATUM PLANE Z.
  - $\triangle 4$ . DATUM Z (SEATING PLANE) IS DEFINED BY THE SPHERICAL CROWNS OF THE SOLDER BALLS.
  - $\triangle 5$ . PARALLELISM MEASUREMENT SHALL EXCLUDE ANY EFFECT OF MARK ON TOP SURFACE OF PACKAGE.

MILLIMETERS		
DIM	MIN	MAX
A	1.25	1.60
A1	0.27	0.47
A2	1.16	REF
b	0.45	0.55
D	15.00	BSC
E	15.00	BSC
e	1.00	BSC
S	0.50	BSC

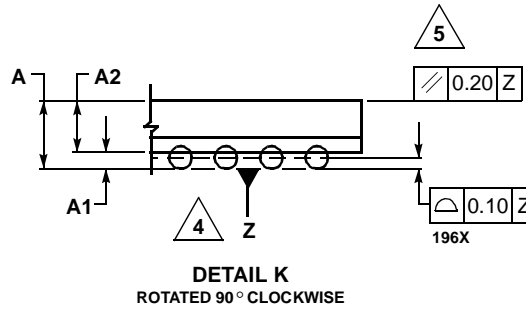
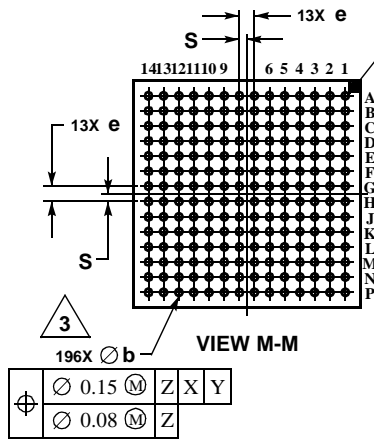



## Section 25. Ordering Information

### 25.1 Contents

25.2 Introduction . . . . .647

25.3 MC Order Numbers . . . . .647

### 25.2 Introduction

This section contains instructions for ordering the MMC2114, MMC2113, and MMC2112.

### 25.3 MC Order Numbers

**Table 25-1. MC Order Numbers**

MC Order Number <sup>(1)</sup>	Operating Temperature Range
MMC2114CFCPU33 MMC2113CFCPU33	-40°C to +85°C
MMC2114CFCPV33 MMC2113CFCPV33 MMC2112CCPV33	-40°C to +85°C
MMC2114CFCVF33 MMC2113CFCVF33 MMC2112CCVF33	-40°C to +85°C

1. PU = 100-pin 14 x 14 mm low-profile quad flat pack (LQFP)  
 PV = 144-pin 20 x 20 mm LQFP  
 VF = 196-pin plastic molded array process ball grid array (MAPBGA)





## Appendix A. Security

### A.1 Contents

A.2	Security Philosophy/Strategy . . . . .	649
A.3	MCU Operation with Security Enabled . . . . .	650
A.4	FLASH Access Blocking Mechanisms . . . . .	650
A.4.1	Forced Operating Mode Selection . . . . .	650
A.4.2	Disabled OnCE Access . . . . .	651

### A.2 Security Philosophy/Strategy

Members of the M•CORE microcontroller family with the SGFM (second generation FLASH for M•CORE) module incorporate features that prevent unauthorized users from reading the contents of the SGFM array.

The security mechanism comprises several hardware interlocks that block the means by which an unauthorized user could gain access to the FLASH array. Apart from dedicated non-volatile memory bits in the SGFM array that engage security, the interlocking mechanism consists exclusively of digital logic constructs that require no special processing.

Thorough MCU security must incorporate both hardware and software considerations. While the MMC2113 and MMC2114 provide the necessary hardware interlocks, it is incumbent upon the user to write software that minimizes the potential for unauthorized code and data access. In particular, if firmware-based debug, diagnostic, or update interfaces are needed, they should be protected with passwords that are not easily compromised. Even brute force hacking attempts can be foiled by incorporating exponential time delays after failed password entries. When used together, the FLASH back door security key and an appropriately defined software construct can provide both password protection and product identification or serialization features.

### A.3 MCU Operation with Security Enabled

Once the FLASH has been programmed with application code, the MCU can be secured by programming the security bytes located in the SGFM configuration field. These non-volatile bytes will keep the MCU secure through reset and power down. Only two bytes within this field are used to enable or disable security. Refer to the [Section 10. Second Generation FLASH for M•CORE \(SGFM\)](#) for the state of the security bytes and the resulting state of security.

When FLASH security is enabled, the MCU will boot only in single-chip mode and will fetch its reset vector from address 0x0000\_0000 of the on-chip FLASH. The M•CORE CPU will fetch and execute opcodes from the on-chip FLASH or on-chip SRAM if user code is copied there. Normal program execution is not affected by enabling FLASH security.

### A.4 FLASH Access Blocking Mechanisms

M•CORE microcontrollers have several operating functional and test modes. Effective FLASH security must address operating mode selection and anticipate modes in which the on-chip FLASH can be compromised and read without explicit user permission. Blocking the two currently identified means for doing this are outlined in the subsections that follow.

#### A.4.1 Forced Operating Mode Selection

The chip configuration module (CCM) determines, at boot time, in which of the four functional modes the MCU will operate. These modes are:

- Master mode
- Single-chip mode
- Emulation mode
- Factory access slave test (FAST) mode

When FLASH security is enabled, the MCU will boot only in single-chip mode and will fetch its reset vector from address 0x0000\_0000 of the on-chip FLASH.

This security affords protection only to applications in which the MCU operates in single-chip mode. Operating in any other mode would make the external bus interface (EBI) available and would be inherently insecure.

When security is enabled, any attempt to override the default single-chip operating mode by asserting the reset configuration ( $\overline{\text{RCON}}$ ) pin in conjunction with mode select inputs D26, D17, and D16 will be ignored. When security is enabled, override will be allowed only for the RPLLSEL, RPLLREF, and RLOAD bits in the RCON register. These bits are overridden by asserting  $\overline{\text{RCON}}$  in conjunction with appropriate logic levels applied to the D[23:22] pins (RPLLSEL and RPLLREF) and the D21 pin (RLOAD). The override inputs for all other RCON bits will be ignored.

#### A.4.2 Disabled OnCE Access

On-chip FLASH can be read by issuing commands across the OnCE port which is the debug interface for the M•CORE CPU. The  $\overline{\text{TRST}}$ , TCLK, TMS, TDO, and TDI pins comprise a JTAG (Joint Test Action Group) interface onto which the OnCE port functionality is mapped. When the MCU boots, the top level JTAG TAP (test access port) is active and provides the chip's boundary scan capability and access to its ID register.

OnCE port features are enabled by:

- Asserting the debug enable ( $\overline{\text{DE}}$ ) input for two TCLK periods when  $\overline{\text{TRST}}$  is negated
- Shifting the ENABLE\_MCU\_ONCE command into the TAP controller's instruction register (IR), entering the UPDATE\_IR state and returning to the RUN\_TEST/IDLE state.

Proper implementation of FLASH security requires that no access to the OnCE port is provided when security is enabled. OnCE port access is

blocked in such a way that the JTAG boundary scan feature is still usable when security is enabled. Please refer to [Section 22. JTAG Test Access Port and OnCE](#) for further information on boundary scan operation.

If security is inadvertently enabled on the MCU, a lockout recovery mechanism allows the on-chip FLASH to be completely erased (including the configuration field), thus disabling security. This does not compromise security as all FLASH physical blocks are erased before security is disabled during the next reset or power-up sequence. To activate lockout recovery, the JTAG public instruction LOCKOUT\_RECOVERY must first be shifted into the top level TAP controller's instruction register. The LOCKOUT\_RECOVERY instruction has an associated 7-bit data register that is used to control the clock divider circuit within the SGFM module. This divider controls the frequency of the SGFM state machine clock and must be set with an appropriate value before the lockout recovery sequence can begin. Refer to [Section 10. Second Generation FLASH for M-CORE \(SGFM\)](#) for more details on setting this register value.

Once the LOCKOUT\_RECOVERY instruction has been shifted into the instruction register, the clock divider value must be shifted into the corresponding 7-bit data register. After the data register has been updated, the user must transition the TAP controller into the RUN-TEST/IDLE state for the lockout recovery sequence to commence. The controller must remain in the RUN-TEST/IDLE state until the erase sequence is complete. See [Section 22. JTAG Test Access Port and OnCE](#) for further details on controlling transitions of the TAP controller. It is important to note that the LOCKOUT\_RECOVERY instruction is only effective on a secured MCU. Using this instruction on an unsecured device has no effect.

**NOTE:** *Once the lockout recovery sequence is complete, both the JTAG TAP controller (by asserting TRST) and the MCU (by asserting RESET) must be reset to resume normal unsecured operation.*



**Freescale Semiconductor, Inc.**

**Freescale Semiconductor, Inc.**

**For More Information On This Product,  
Go to: [www.freescale.com](http://www.freescale.com)**

## HOW TO REACH US:

### USA/EUROPE/LOCATIONS NOT LISTED:

Motorola Literature Distribution;  
P.O. Box 5405, Denver, Colorado 80217  
1-303-675-2140 or 1-800-441-2447

### JAPAN:

Motorola Japan Ltd.; SPS, Technical Information Center,  
3-20-1, Minami-Azabu Minato-ku, Tokyo 106-8573 Japan  
81-3-3440-3569

### ASIA/PACIFIC:

Motorola Semiconductors H.K. Ltd.;  
Silicon Harbour Centre, 2 Dai King Street,  
Tai Po Industrial Estate, Tai Po, N.T., Hong Kong  
852-26668334

### TECHNICAL INFORMATION CENTER:

1-800-521-6274

### HOME PAGE:

<http://www.motorola.com/semiconductors>

Information in this document is provided solely to enable system and software implementers to use Motorola products. There are no express or implied copyright licenses granted hereunder to design or fabricate any integrated circuits or integrated circuits based on the information in this document.

Motorola reserves the right to make changes without further notice to any products herein. Motorola makes no warranty, representation or guarantee regarding the suitability of its products for any particular purpose, nor does Motorola assume any liability arising out of the application or use of any product or circuit, and specifically disclaims any and all liability, including without limitation consequential or incidental damages. "Typical" parameters which may be provided in Motorola data sheets and/or specifications can and do vary in different applications and actual performance may vary over time. All operating parameters, including "Typicals" must be validated for each customer application by customer's technical experts. Motorola does not convey any license under its patent rights nor the rights of others. Motorola products are not designed, intended, or authorized for use as components in systems intended for surgical implant into the body, or other applications intended to support or sustain life, or for any other application in which the failure of the Motorola product could create a situation where personal injury or death may occur. Should Buyer purchase or use Motorola products for any such unintended or unauthorized application, Buyer shall indemnify and hold Motorola and its officers, employees, subsidiaries, affiliates, and distributors harmless against all claims, costs, damages, and expenses, and reasonable attorney fees arising out of, directly or indirectly, any claim of personal injury or death associated with such unintended or unauthorized use, even if such claim alleges that Motorola was negligent regarding the design or manufacture of the part.



Motorola and the Stylized M Logo are registered in the U.S. Patent and Trademark Office. digital dna is a trademark of Motorola, Inc. All other product or service names are the property of their respective owners. Motorola, Inc. is an Equal Opportunity/Affirmative Action Employer.

© Motorola, Inc. 2002

MMC2114/D

**For More Information On This Product,  
Go to: [www.freescale.com](http://www.freescale.com)**

# Mouser Electronics

Authorized Distributor

Click to View Pricing, Inventory, Delivery & Lifecycle Information:

[NXP:](#)

[MMC2114CFCAF33](#) [MMC2114CFCAG33](#) [MMC2114CFCVF33](#) [MMC2114CFCVM33](#)