

## 3-Axis Digital Angular Rate Gyroscope

FXAS21002C is a small, low-power, yaw, pitch, and roll angular rate gyroscope with 16 bit ADC resolution. The full-scale range is adjustable from  $\pm 250^\circ/\text{s}$  to  $\pm 2000^\circ/\text{s}$ . It features both I<sup>2</sup>C and SPI interfaces.

FXAS21002C is capable of measuring angular rates up to  $\pm 2000^\circ/\text{s}$ , with output data rates (ODR) from 12.5 to 800 Hz. An integrated Low-Pass Filter (LPF) allows the host application to limit the digital signal bandwidth. The device may be configured to generate an interrupt when a user-programmable angular rate threshold is crossed on any one of the enabled axes.

FXAS21002C is available in a plastic, 24-lead QFN package; the device is guaranteed to operate over the extended temperature range of  $-40^\circ\text{C}$  to  $+85^\circ\text{C}$ .

### Features

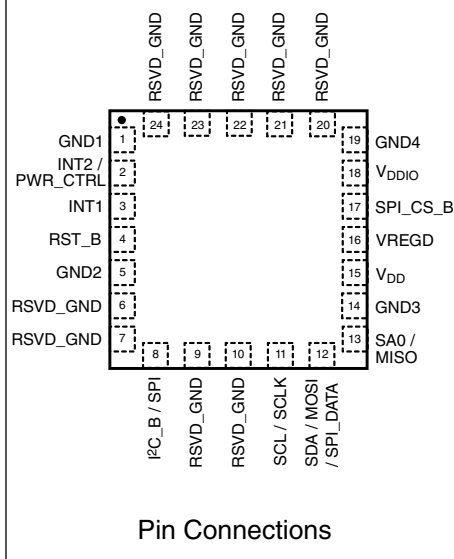
- Supply voltage ( $V_{DD}$ ) from 1.95 V to 3.6 V
- Interface Supply voltage ( $V_{DDIO}$ ) from 1.62 V to  $V_{DD} + 0.3$  V
- 16-bit digital output resolution
- $\pm 250/500/1000/2000^\circ/\text{s}$  configurable full-scale dynamic ranges
- Full-Scale Range boost function enables FSR's up to  $\pm 4000$  dps
- Angular rate sensitivity of  $0.0625^\circ/\text{s}$  in  $\pm 2000^\circ/\text{s}$  FSR mode
- Noise spectral density of  $25$  mdps/ $\sqrt{\text{Hz}}$  at 64 Hz bandwidth (200 Hz ODR)
- Current consumption in Active mode is 2.7 mA
- Fast transition from Standby to Active mode (60 ms)
- Supported digital interfaces include:
  - I<sup>2</sup>C Standard and Fast Mode (100/400 kHz)
  - SPI Interface (3- and 4-wire modes, up to 2 MHz)
- FIFO buffer is 192 bytes (32 X/Y/Z samples) with stop and circular operating modes
- Output Data Rates (ODR) from 12.5 to 800 Hz; programmable low-pass filter to further limit digital output data bandwidth
- Low power standby mode
- Power mode transition control via external pin for accelerometer-based power management (motion interrupt)
- Rate Threshold interrupt function
- Integrated self-test function
- 8-bit temperature sensor

## FXAS21002C



24 QFN  
4 mm x 4 mm x 1 mm  
Case 2209-01

### Top View





### Typical Applications

- Industrial and consumer grade robots, UAVs, and RC vehicles
- Game controller
- Gyro-stabilized electronic compass
- Orientation determination
- Gesture-based user interfaces and Human Machine Interface (HMI)
- Indoor navigation
- Mobile phones and tablets
- Virtual and augmented reality devices (including glasses)

### Ordering Information

| Part Number   | Temperature Range | Package Description | Shipping            |
|---------------|-------------------|---------------------|---------------------|
| FXAS21002CQR1 | -40 °C to +85 °C  | QFN                 | Tape and reel (1 k) |

### Related Documentation

The FXAS21002C device features and operations are described in a variety of reference manuals, user guides, and application notes. To find the most-current versions of these documents, go to [freescale.com/FXAS21002C](http://freescale.com/FXAS21002C), and then click on the Documentation tab.

# Table of Contents

|       |   |    |      |  |    |
|-------|---|----|------|--|----|
| 1     | General Description.....                              | 4  | 6    | Register Descriptions.....   | 30 |
| 1.1   | Block Diagram.....                                    | 4  | 6.1  | 0x00: STATUS.....  | 30 |
| 1.2   | Pinout.....   | 4  | 6.2  | 0x01–0x06: OUT_X_MSB, OUT_X_LSB,<br>OUT_Y_MSB, OUT_Y_LSB, OUT_Z_MSB,<br>OUT_Z_LSB..... | 31 |
| 1.3   | System Connections.....                               | 5  | 6.3  | 0x07: DR_STATUS.....   | 33 |
| 1.3.1 | Typical Application Circuit—I2C Mode.....             | 5  | 6.4  | 0x08: F_STATUS.....  | 35 |
| 1.3.2 | Typical Application Circuit—SPI Mode.....             | 6  | 6.5  | 0x09: F_SETUP.....   | 35 |
| 1.4   | Sensitive Axes Orientations and Polarities.....       | 7  | 6.6  | 0x0A: F_EVENT.....   | 36 |
| 2     | Mechanical and Electrical Specifications.....         | 8  | 6.7  | 0x0B: INT_SOURCE_FLAG.....   | 37 |
| 2.1   | Absolute Maximum Ratings.....                         | 8  | 6.8  | 0x0C: WHO_AM_I.....  | 38 |
| 2.2   | Operating Conditions.....                             | 9  | 6.9  | 0x0D: CTRL_REG0.....   | 38 |
| 2.3   | Mechanical Characteristics.....                       | 9  | 6.10 | 0x0E: RT_CFG.....  | 40 |
| 2.4   | Electrical Characteristics.....                       | 10 | 6.11 | 0x0F: RT_SRC.....  | 41 |
| 2.5   | Temperature Sensor Characteristics.....               | 11 | 6.12 | 0x10: RT_THS.....  | 43 |
| 3     | Digital Interfaces.....                               | 12 | 6.13 | 0x11: RT_COUNT.....  | 44 |
| 3.1   | I <sup>2</sup> C Interface.....                       | 12 | 6.14 | 0x12: TEMP.....  | 44 |
| 3.1.1 | I <sup>2</sup> C Operation.....                       | 14 | 6.15 | 0x13: CTRL_REG1.....   | 45 |
| 3.1.2 | I <sup>2</sup> C Read Operations.....                 | 15 | 6.16 | 0x14: CTRL_REG2.....   | 47 |
| 3.1.3 | I <sup>2</sup> C Write Operations.....                | 15 | 6.17 | 0x15: CTRL_REG3.....   | 48 |
| 3.2   | SPI Interface.....                                    | 17 | 7    | Printed Circuit Board Layout and Device Mounting.....                                  | 50 |
| 3.2.1 | General SPI Operation.....                            | 17 | 7.1  | Printed Circuit Board Layout.....  | 50 |
| 3.2.2 | SPI Write Operations with 3- and 4-Wire<br>Modes..... | 18 | 7.2  | Overview of Soldering Considerations.....  | 51 |
| 3.2.3 | SPI Read Operations with 4-Wire Mode.....             | 20 | 7.3  | Halogen Content.....   | 52 |
| 3.2.4 | SPI Read Operations with 3-Wire Mode.....             | 21 | 8    | Package Information.....   | 52 |
| 3.2.5 | SPI Timing Specifications (4-wire mode).....          | 21 | 8.1  | Product Identification Markings.....   | 52 |
| 3.2.6 | SPI Timing Specifications (3-wire mode).....          | 23 | 8.2  | Tape and Reel Information.....   | 52 |
| 4     | Modes of Operation.....                               | 24 | 8.3  | Package Description.....   | 53 |
| 5     | Functionality.....                                    | 26 | 9    | Revision History.....  | 55 |
| 5.1   | FIFO Data Buffer.....                                 | 27 |      |  |    |
| 5.2   | Rate Threshold Detection Function.....                | 28 |      |  |    |

# 1 General Description

## 1.1 Block Diagram

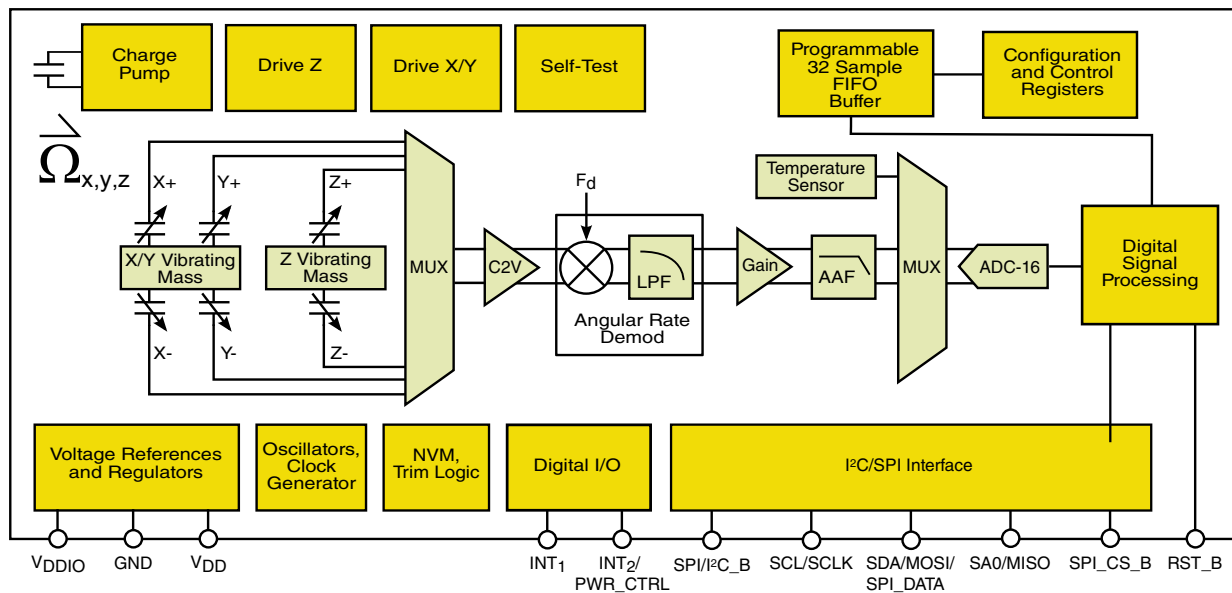


Figure 1. Block Diagram

## 1.2 Pinout

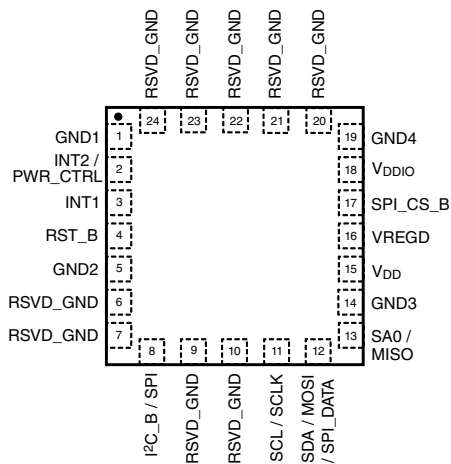


Figure 2. Device pinout (top view)

**Table 1. Pin functions**

| Pin | Name                         | Function  |
|-----|------------------------------|---|
| 1   | GND1                         | Ground  |
| 2   | INT2 / PWR_CTRL <sup>1</sup> | Interrupt Output 2 / Power state transition control input   |
| 3   | INT1                         | Interrupt Output 1  |
| 4   | RST_B                        | Reset input, active low. Connect this pin to V <sub>DDIO</sub> if unused.   |
| 5   | GND2                         | Ground  |
| 6   | RSVD_GND                     | Reserved - Must be tied to ground   |
| 7   | RSVD_GND                     | Reserved - Must be tied to ground   |
| 8   | I <sup>2</sup> C_B / SPI     | Digital interface selection pin. This pin must be tied high to select SPI interface mode, or low to select I <sup>2</sup> C interface mode.   |
| 9   | RSVD_GND                     | Reserved pin—must be tied to ground   |
| 10  | RSVD_GND                     | Reserved pin—must be tied to ground   |
| 11  | SCL/SCLK                     | I <sup>2</sup> C / SPI clock  |
| 12  | SDA / MOSI / SPI_Data        | I <sup>2</sup> C data / SPI 4-wire Master Out Slave In / SPI 3-wire data In/Out <sup>2</sup>  |
| 13  | SA0/MISO                     | I <sup>2</sup> C address bit0 / SPI 4-wire Master In Slave Out  |
| 14  | GND3                         | Ground  |
| 15  | V <sub>DD</sub>              | Supply voltage  |
| 16  | V <sub>REGD</sub>            | Digital regulator output. Connect a 0.1 μF capacitor between this pin and ground  |
| 17  | SPI_CS_B                     | SPI chip select input, active low. This pin must be held logic high when operating in I <sup>2</sup> C interface mode (I <sup>2</sup> C_B/SPI set to ground) to ensure correct operation. |
| 18  | V <sub>DDIO</sub>            | Interface supply voltage  |
| 19  | GND4                         | Ground  |
| 20  | RSVD_GND                     | Reserved - Must be tied to ground   |
| 21  | RSVD_GND                     | Reserved - Must be tied to ground   |
| 22  | RSVD_GND                     | Reserved - Must be tied to ground   |
| 23  | RSVD_GND                     | Reserved - Must be tied to ground   |
| 24  | RSVD_GND                     | Reserved - Must be tied to ground   |

1. INT2/PWR\_CTRL becomes a high-impedance input with weak internal pull-up resistor when **CTRLREG3[EXTCTRLLEN] = 1**; the pull-up resistor is referenced to V<sub>DDIO</sub>.
2. MOSI becomes a bidirectional data pin when FXAS21002C is operated in 3-wire SPI mode with **CTRL\_REG0[SPIW]=1**.

### 1.3 System Connections

The FXAS21002C offers the choice of interfacing with a host processor through either I<sup>2</sup>C or SPI interfaces. [Figure 3](#) and [Figure 4](#) show the recommended circuit connections for implementing both interface options.

### 1.3.1 Typical Application Circuit—I<sup>2</sup>C Mode

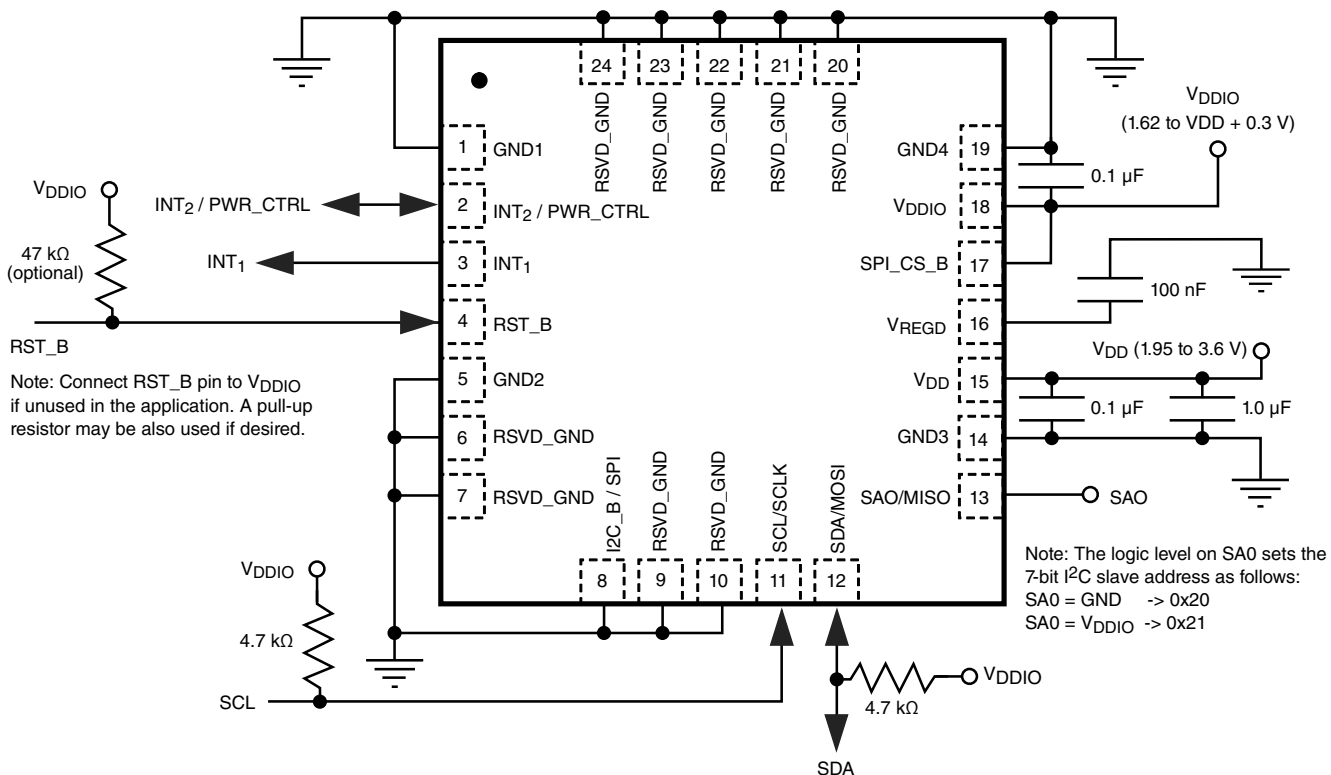


Figure 3. I<sup>2</sup>C mode electrical connections

### 1.3.2 Typical Application Circuit—SPI Mode

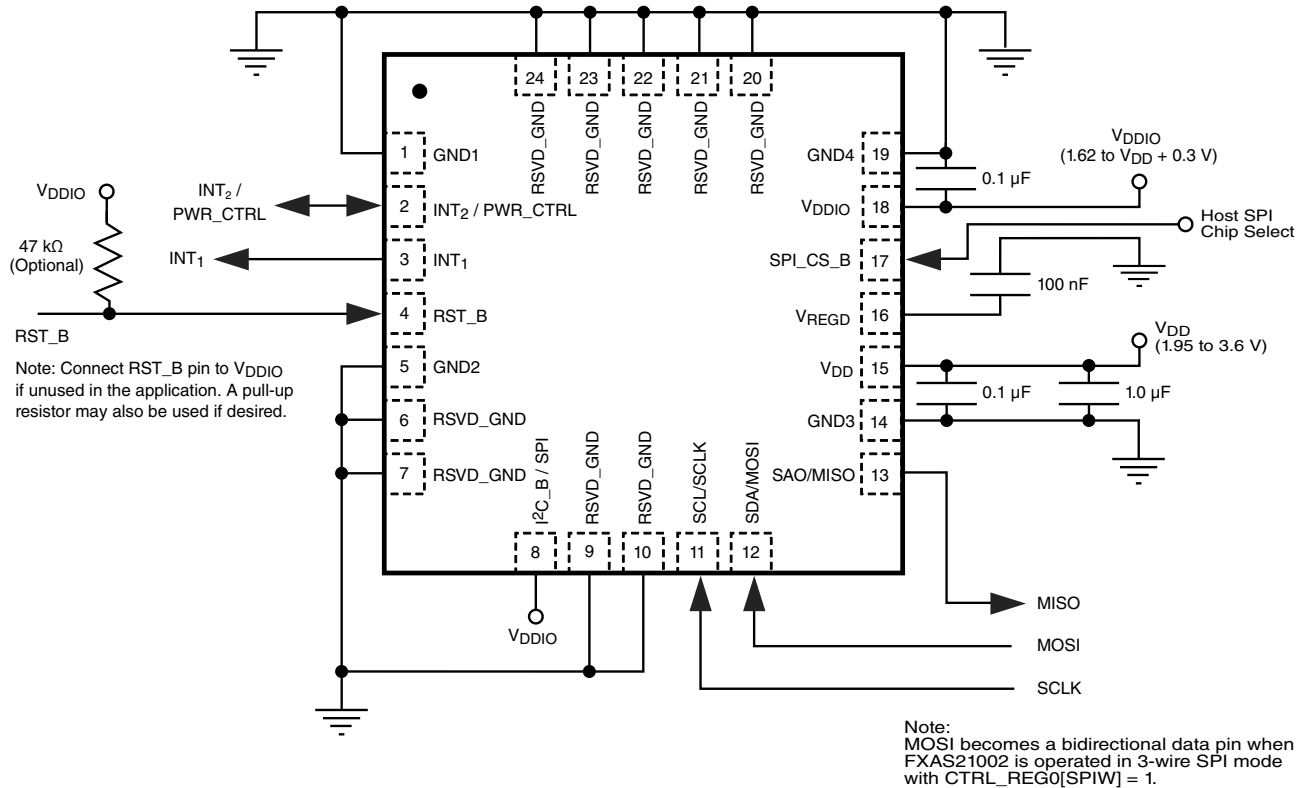


Figure 4. SPI mode electrical connections

### 1.4 Sensitive Axes Orientations and Polarities

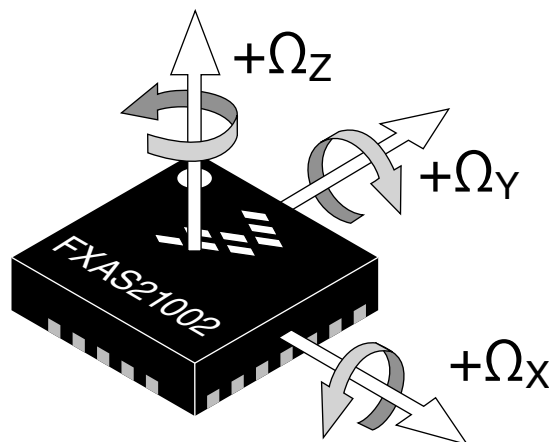


Figure 5. Reference frame for rotational measurement

## 2 Mechanical and Electrical Specifications

### 2.1 Absolute Maximum Ratings

Absolute maximum ratings are the limits the device can be exposed to without permanently damaging it. Absolute maximum ratings are stress ratings only; functional operation at these ratings is not guaranteed. Exposure to absolute maximum ratings conditions for extended periods may affect device reliability.

This device contains circuitry to protect against damage due to high static voltage or electrical fields. It is advised, however, that normal precautions be taken to avoid application of any voltages higher than maximum-rated voltages to this high-impedance circuit. Reliability of operation is enhanced if unused inputs are tied to an appropriate logic voltage level (for instance, either GND or  $V_{DD}$ ).

**Table 2. Absolute maximum ratings**

| Rating  | Symbol     | Min  | Max              | Unit         |
|---|------------|------|------------------|--------------|
| Supply voltage  | $V_{DD}$   | -0.3 | 3.6              | V            |
| Interface supply voltage  | $V_{DDIO}$ | -0.3 | 3.6              | V            |
| Input voltage on any control pin (SA0, SCL, SDA, RST_B, PWR_CTRL) | $V_{IN}$   | -0.3 | $V_{DDIO} + 0.3$ | V            |
| Maximum Acceleration (all axes, 100 $\mu$ s)                      | $g_{max}$  | —    | 5000             | <i>g</i>     |
| Operating temperature   | $T_{OP}$   | -40  | +85              | $^{\circ}$ C |
| Storage temperature   | $T_{STG}$  | -40  | +125             | $^{\circ}$ C |

**Table 3. ESD and latch-up protection characteristics**

| Rating                                 | Symbol    | Value      | Unit |
|--|-----------|------------|------|
| Human body model (HBM)                 | $V_{HBM}$ | $\pm 2000$ | V    |
| Machine model (MM)                     | $V_{MM}$  | $\pm 200$  | V    |
| Charge device model (CDM)              | $V_{CDM}$ | $\pm 500$  | V    |
| Latch-up current at $T = 85^{\circ}$ C | $I_{LU}$  | $\pm 100$  | mA   |

| Caution |   |
|---------|---|
|         | This device is sensitive to mechanical shock, improper handling can cause permanent damage to the part. |



|  |  |
|--|--|
|  | <b>Caution</b>   |
|  | This is an ESD sensitive device, improper handling can cause permanent damage to the part. |

## 2.2 Operating Conditions

**Table 4. Nominal operating conditions**

| Rating   | Symbol     | Min              | Typ | Max              | Unit |
|--|------------|------------------|-----|------------------|------|
| Supply voltage   | $V_{DD}$   | 1.95             | —   | 3.6              | V    |
| Interface supply voltage   | $V_{DDIO}$ | 1.62             | —   | $V_{DD} + 0.3$   | V    |
| Digital high level input voltage: SCL/SCLK, SDA/MOSI/SPI_DATA, SA0/MISO, SPI/I <sup>2</sup> C_B, RST_B, INT2/PWR_CTRL, SPI_CS_B pins | $V_{IH}$   | $0.7 * V_{DDIO}$ | —   | —                | V    |
| Digital low level input voltage: SCL/SCLK, SDA/MOSI/SPI_DATA, SA0/MISO, SPI/I <sup>2</sup> C_B, RST_B, INT2/PWR_CTRL, SPI_CS_B pins  | $V_{IL}$   | —                | —   | $0.3 * V_{DDIO}$ | V    |
| Operating temperature  | Top        | -40              | +25 | +85              | °C   |

## 2.3 Mechanical Characteristics

**Table 5. Mechanical characteristics**

| Parameter                                       | Symbol       | Test Conditions    | Min | Typ       | Max | Unit     |
|---|--------------|--------------------|-----|-----------|-----|----------|
| ADC Resolution                                  | n            | —                  | —   | 16        | —   | bits     |
| Full-scale range                                | FSR          | CTRL_REG0[FS] = 00 | —   | ±2000     | —   | dps      |
|   |              | CTRL_REG0[FS] = 01 |     | ±1000     |     |          |
|   |              | CTRL_REG0[FS] = 10 |     | ±500      |     |          |
|   |              | CTRL_REG0[FS] = 11 |     | ±250      |     |          |
| Sensitivity                                     | $S_o$        | CTRL_REG0[FS] = 00 | —   | 62.5      | —   | mdps/LSB |
|   |              | CTRL_REG0[FS] = 01 |     | 31.25     |     |          |
|   |              | CTRL_REG0[FS] = 10 |     | 15.625    |     |          |
|   |              | CTRL_REG0[FS] = 11 |     | 7.8125    |     |          |
| Sensitivity Temperature Coefficient             | $\epsilon_T$ | -40 to +85 °C      | —   | XY: ±0.08 | —   | % / °C   |
|   |              |                    |     | Z: ±0.01  |     |          |
| Zero-rate Offset                                | $D_O$        | CTRL_REG0[FS] = 00 | —   | ±25       | —   | LSB      |
| Zero-rate Offset, Post-Board Mount <sup>1</sup> | $D_{O-PBM}$  | CTRL_REG0[FS] = 00 | —   | ±50       | —   | LSB      |

Table continues on the next page...

**Table 5. Mechanical characteristics (continued)**

| Parameter   | Symbol             | Test Conditions  | Min  | Typ                   | Max   | Unit    |
|---|--------------------|--|------|-----------------------|-------|---------|
| Zero Rate Bias Temperature Coefficient  | $D_T$              | -40 to +85 °C  | —    | XY: ±0.02<br>Z: ±0.01 | —     | dps/°C  |
| Cross axis sensitivity  | CAS                | $\max(S_{XY}, S_{XZ}, S_{YX}, S_{YZ}, S_{ZX}, S_{ZY})$     | —    | ±1.5                  | —     | %       |
| Integral nonlinearity (deviation from linear response)  | INL                | CTRL_REG0[FS] = 00   | —    | ±0.5                  | —     | %FSR    |
| Self-test output change <sup>2</sup>  | STOC               | CTRL_REG0[FS] = 00   | 7000 | 16000                 | 25000 | LSB     |
| Maximum output data rate  | ODR <sub>MAX</sub> | —  | —    | 800                   | —     | Hz      |
| Noise density   | ND                 | ODR = 200 Hz,<br>CTRL_REG0[FS] = 00,<br>CTRL_REG0[BW] = 00 | —    | 0.025                 | —     | dps/√Hz |
| Test conditions (unless otherwise noted):   |                    |  |      |                       |       |         |
| <ul style="list-style-type: none"> <li>• <math>V_{DD} = 2.5\text{ V}</math></li> <li>• <math>V_{DDIO} = 1.8\text{ V}</math></li> <li>• <math>T = 25\text{ °C}</math></li> </ul> |                    |  |      |                       |       |         |

1. Post Board Mount Offset Specifications are based on an eight-layer PCB.
2. The Self-Test function can be used to verify the correct functioning of the ASIC measurement chain and gyro drive circuitry. The Self-Test function will only produce a meaningful result when the device is maintained stationary during the test. The Self-Test output value will be either positive or negative due to factory trimming, therefore, the absolute value of the Self-Test result should be used.

## 2.4 Electrical Characteristics

**Table 6. Electrical characteristics**

| Parameter   | Symbol          | Test conditions | Min              | Typ | Max          | Unit |
|---|-----------------|-----------------|------------------|-----|--------------|------|
| Supply voltage  | $V_{DD}$        | —               | 1.95             | 2.5 | 3.6          | V    |
| Interface supply  | $V_{DDIO}$      | —               | 1.62             | —   | $V_{DD}+0.3$ | V    |
| Current consumption in Active mode  | $I_{ddAct}$     | Active mode     | —                | 2.7 | —            | mA   |
| Current consumption in Ready mode   | $I_{ddRdy}$     | Ready mode      | —                | 1.6 | —            | mA   |
| Supply current drain in Standby mode  | $I_{ddStby}$    | Standby mode    | —                | 2.8 | —            | μA   |
| Supply current in Standby mode over temperature   | $I_{DDSTBY-OT}$ | -40 ≤ T ≤ 85 °C | —                | —   | 7.5          | μA   |
| Digital high level input voltage SCL/SCLK, SDA/MOSI/ SPI_DATA, SA0/MISO, SPI/ I <sup>2</sup> C_B, RST_B, INT2/ PWR_CTRL, SPI_CS_B | $V_{IH}$        | —               | $0.7 * V_{DDIO}$ | —   | —            | V    |

Table continues on the next page...

**Table 6. Electrical characteristics (continued)**

| Parameter  | Symbol                | Test conditions                               | Min                     | Typ        | Max                     | Unit  |
|--|-----------------------|---|-------------------------|------------|-------------------------|-------|
| Digital low level input voltage<br>SCL/SCLK, SDA/MOSI/<br>SPI_DATA, SA0/MISO, SPI/<br>I <sup>2</sup> C_B, RST_B, INT2/<br>PWR_CTRL, SPI_CS_B | VIL                   | —   | —                       | —          | 0.3 * V <sub>DDIO</sub> | V     |
| High-level output voltage<br>INT1, INT2/PWR_CTRL,<br>SDA/MOSI/SPI_DATA, SA0/<br>MISO   | VOH                   | I <sub>O</sub> = 1 mA                         | 0.9 * V <sub>DDIO</sub> | —          | —                       | V     |
| Low-level output voltage INT1,<br>INT2/PWR_CTRL, SDA/<br>MOSI/SPI_DATA, SA0/MISO   | VOL                   | I <sub>O</sub> = 1 mA                         | —                       | —          | 0.1 * V <sub>DDIO</sub> | V     |
| Low-level output voltage SDA   | VOL <sub>SDA1</sub>   | I <sub>O</sub> = 3 mA, V <sub>DDIO</sub> ≥ 2V | —                       | —          | 0.4 * V <sub>DDIO</sub> | V     |
|  | VOL <sub>SDA2</sub>   | I <sub>O</sub> = 3 mA, V <sub>DDIO</sub> < 2V | —                       | —          | 0.2 * V <sub>DDIO</sub> |       |
| Output Data Rate frequency<br>tolerance  | ODR <sub>TOL</sub>    | —   | —                       | ±2.5       | —                       | % ODR |
| Output Signal bandwidth  | BW                    | —   | 4                       | < ODR/2    | 256                     | Hz    |
| Standby to Active mode<br>transition time  | T <sub>Stdy-Act</sub> | —   | —                       | 1/ODR + 60 | —                       | ms    |
| Ready to Active mode<br>transition time  | T <sub>Rdy-Act</sub>  | —   | —                       | 1/ODR + 5  | —                       | ms    |
| Test conditions (unless otherwise noted):  |                       |   |                         |            |                         |       |
| <ul style="list-style-type: none"> <li>• V<sub>DD</sub> = 2.5 V</li> <li>• V<sub>DDIO</sub> = 1.8 V</li> <li>• T = 25°C</li> </ul>           |                       |   |                         |            |                         |       |

## 2.5 Temperature Sensor Characteristics

**Table 7. Temperature sensor characteristics**

| Characteristic   | Symbol            | Condition(s) | Min | Typ | Max | Unit   |
|--|-------------------|--------------|-----|-----|-----|--------|
| Full-scale range   | T <sub>FSR</sub>  | —            | -40 | —   | +85 | °C     |
| Operating temperature  | T <sub>OP</sub>   | —            | -40 | +25 | +85 | °C     |
| Sensitivity  | T <sub>SENS</sub> | —            | —   | 1   | —   | °C/LSB |
| Test conditions (unless otherwise noted):  |                   |              |     |     |     |        |
| <ul style="list-style-type: none"> <li>• V<sub>DD</sub> = 2.5 V</li> <li>• V<sub>DDIO</sub> = 1.8 V</li> </ul> |                   |              |     |     |     |        |

### 3 Digital Interfaces

The registers embedded inside the device are accessed through either an I<sup>2</sup>C or an SPI serial interface. To enable either interface, the V<sub>DDIO</sub> line must be connected to the interface supply voltage. If V<sub>DD</sub> is not present and V<sub>DDIO</sub> is present, FXAS21002C is in shutdown mode and communications on the interface are ignored. If V<sub>DDIO</sub> is maintained, V<sub>DD</sub> can be powered off and the communications pins will be in a high impedance state. This will allow communications to continue on the bus with other devices.

**Table 8. Serial interface pin descriptions**

| Pin name               | Pin description  |
|------------------------|--|
| V <sub>DDIO</sub>      | Digital interface power  |
| SPI_CS_B               | SPI chip select  |
| SCL/SCLK               | I <sup>2</sup> C/SPI serial clock  |
| SDA/MOSI/SPI Data      | I <sup>2</sup> C serial data/SPI master serial data out slave serial data in /SPI 3-wire data input/output   |
| SA0/MISO               | I <sup>2</sup> C least significant bit of the device address/SPI master serial data in slave serial data out |
| I <sup>2</sup> C_B/SPI | Digital interface mode selection pin   |

#### 3.1 I<sup>2</sup>C Interface

To use the I<sup>2</sup>C interface, the I<sup>2</sup>C\_B/SPI (pin 8) pin must be connected to GND (logic low) and the SPI\_CS\_B (pin 17) must be made logic high (by providing it a voltage equal to V<sub>DDIO</sub>). FXAS21002C's I<sup>2</sup>C interface is compliant with I<sup>2</sup>C interface specification for Standard and Fast modes as outlined in the *I<sup>2</sup>C-bus specification and user manual - Rev 4*, published by NXP Semiconductors. The 7-bit slave addresses that may be assigned to the device are 0x20 (with SA0 = 0) and 0x21 (with SA0 = 1). When I<sup>2</sup>C\_B/SPI is held low, the SA0/MISO pin is used to define the LSB of this I<sup>2</sup>C address. This part does not implement clock stretching. See [Table 9](#) for the I<sup>2</sup>C slave addresses.

**Table 9. I<sup>2</sup>C Slave Addresses**

| Command | Device Address Bit[0] (SA0 pin state) | Slave Address Bits[6:0] | R/W Bit | Slave Address Byte Transmitted by Master |
|---------|---------------------------------------|-------------------------|---------|--|
| Read    | 0                                     | 0x20                    | 1       | 0x41                                     |
| Write   | 0                                     | 0x20                    | 0       | 0x40                                     |
| Read    | 1                                     | 0x21                    | 1       | 0x43                                     |
| Write   | 1                                     | 0x21                    | 0       | 0x42                                     |

The key bus timing constraints are shown in [Table 10](#). The I<sup>2</sup>C timing diagram is shown in [Figure 6](#).

**Table 10. Slave timing values**

| Parameter   | Symbol              | I <sup>2</sup> C Standard Mode <sup>1, 2</sup> |                   | I <sup>2</sup> C Fast Mode <sup>1, 2</sup> |                  | Unit |
|---|---------------------|--|-------------------|--|------------------|------|
|   |                     | Min  | Max               | Min  | Max              |      |
| SCL clock frequency   | f <sub>SCL</sub>    | 0  | 100               | 0  | 400              | kHz  |
| Bus free time between STOP and START conditions   | t <sub>BUF</sub>    | 4.7  | —                 | 1.3  | —                | μs   |
| Hold time (repeated) START condition  | t <sub>HD;STA</sub> | 4.0  | —                 | 0.6  | —                | μs   |
| Set-up time for a repeated START condition  | t <sub>SU;STA</sub> | 4.7  | —                 | 0.6  | —                | μs   |
| Set-up time for a STOP condition  | t <sub>SU;STO</sub> | 4.0  | —                 | 0.6  | —                | μs   |
| SDA valid time <sup>2</sup>   | t <sub>VD;DAT</sub> | —  | 3.45 <sup>3</sup> | —  | 0.9 <sup>3</sup> | μs   |
| SDA valid acknowledge time <sup>4</sup>   | t <sub>VD;ACK</sub> | —  | 3.45 <sup>3</sup> | —  | 0.9 <sup>3</sup> | μs   |
| SDA setup time  | t <sub>SU;DAT</sub> | 250  | —                 | 100 <sup>5</sup>                           | —                | ns   |
| SCL clock low time  | t <sub>LOW</sub>    | 4.7  | —                 | 1.3  | —                | μs   |
| SCL clock high time   | t <sub>HIGH</sub>   | 4.0  | —                 | 0.6  | —                | μs   |
| SDA and SCL rise time   | t <sub>r</sub>      | —  | 1000              | 20   | 300              | ns   |
| SDA and SCL fall time <sup>6</sup>  | t <sub>f</sub>      | —  | 300               | 20*(V <sub>DDIO</sub> /5.5 V)              | 300              | ns   |
| Capacitive load for each bus line <sup>7</sup>  | C <sub>b</sub>      | —  | 400               | —  | 400              | pF   |
| Pulse width of spikes on SDA and SCL that must be suppressed by the internal input filter | t <sub>SP</sub>     | 0  | 50                | 0  | 50               | ns   |

- All values refer to VIH (min) and VIL (max) levels.
- t<sub>VD;DAT</sub> refers to the time for data signal from SCL LOW to SDA output (HIGH or LOW, depending on which one is worse).
- The maximum t<sub>HD;DAT</sub> could be 3.45 μs and 0.9 μs for Standard mode and Fast mode, but must be less than the maximum of t<sub>VD;DAT</sub> or t<sub>VD;ACK</sub> by a transition time.
- t<sub>VD;ACK</sub> = time for acknowledgement signal from SCL LOW to SDA output (HIGH or LOW, depending on which one is worse).
- A Fast-mode I<sup>2</sup>C device can be used in a Standard-mode I<sup>2</sup>C system, but the requirement t<sub>SU;DAT</sub> 250 ns must then be met. Also, the acknowledge timing must meet this set-up time.
- The maximum t<sub>f</sub> for the SDA and SCL bus lines is specified at 300 ns. This allows series protection resistors to be connected between the SDA and the SCL pins and the SDA/SCL bus lines without exceeding the maximum specified t<sub>f</sub>.
- C<sub>b</sub> is the total capacitance of one bus line in pF; the maximum bus capacitance allowable may vary from this value depending on the application operating voltage and frequency.

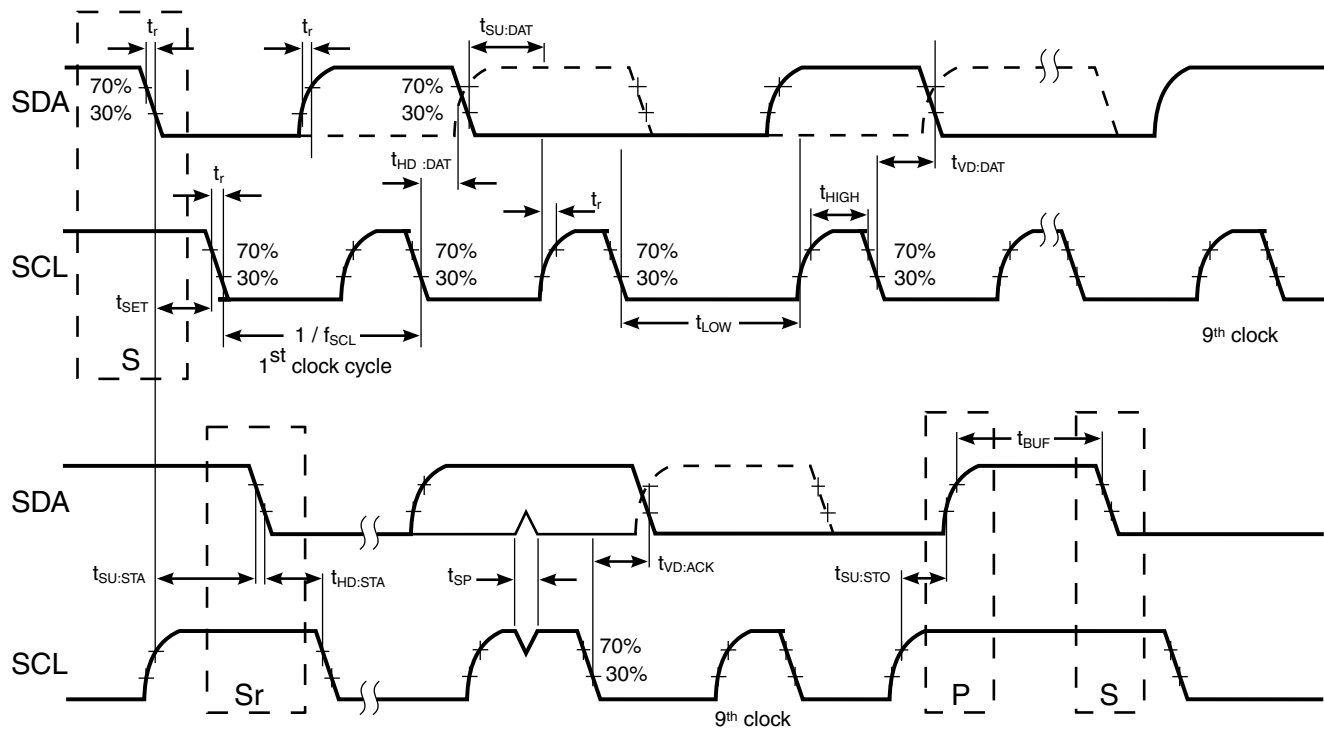


Figure 6. I<sup>2</sup>C timing diagram

### 3.1.1 I<sup>2</sup>C Operation

There are two signals associated with the I<sup>2</sup>C bus: the serial clock line (SCL) and the serial data line (SDA). The SDA is a bidirectional line used for sending and receiving the data to and from the interface. External pull-up resistors connected to  $V_{DDIO}$  are required for SDA and SCL. When the bus is free, the lines are high.

The maximum practical operating frequency for I<sup>2</sup>C in a given system implementation depends on several factors including the pull-up resistor values, and the total bus capacitance (trace + parasitic device capacitances).

A transaction on the bus is started through a start condition (ST) signal, which is defined as a HIGH-to-LOW transition on the data line while the SCL line is held HIGH. After the ST signal has been transmitted by the master, the bus is considered busy. The next byte of data transmitted contains the slave address in the first seven bits, and the eighth bit, the read/write bit, indicates whether the master is receiving data from the slave or transmitting data to the slave. When an address is sent, each device in the system compares the first seven bits after the ST condition with its own address. If they match, the device considers itself addressed by the master. The ninth clock pulse, following the slave address byte (and each subsequent byte) is the acknowledge (ACK).

The transmitter must release the SDA line during the ACK period. The receiver must then pull the data line low so that it remains consistently low during the high period of the acknowledge clock period. The number of bytes per transfer is unlimited. If a receiver can't receive another complete byte of data until it has performed some other function, it can hold the clock line, SCL, low to force the transmitter into a wait state. Data transfer only continues when the receiver is ready for another byte and releases the data line. This delay action is called clock stretching. Not all receiver devices support clock stretching. Not all master devices recognize clock stretching.

A LOW-to-HIGH transition on the SDA line while SCL is high is defined as a stop condition (SP) signal. A write or burst write is always terminated by the master issuing the SP signal. A master should properly terminate a read by not acknowledging a byte at the appropriate time in the protocol. A master may also issue a repeated start signal (SR) during a transfer.

## 3.1.2 I<sup>2</sup>C Read Operations

### 3.1.2.1 Single-Byte Read

The master (or MCU) transmits an ST to the FXAS21002C, followed by the slave address, with the R/W bit set to “0” for a write, and the FXAS21002C sends an acknowledgement. Then, the MCU transmits the address of the register to read and the FXAS21002C sends an acknowledgement. The MCU transmits an SR, followed by the byte containing the slave address and the R/W bit set to “1” for a read from the previously selected register. The FXAS21002C then acknowledges and transmits the data from the requested register. The master transfers a NACK followed by an SP, signaling an end of transmission.

### 3.1.2.2 Multiple-Byte Read

When performing a multiple-byte or burst read, the FXAS21002C increments the register address read pointer after a read command is received. Therefore, after following the steps of a single-byte read, multiple bytes of data can be read from sequential registers after each FXAS21002C ACK is received. This continues until the master transfers a NACK followed by an SP, signaling an end of transmission.

### 3.1.3 I<sup>2</sup>C Write Operations

#### 3.1.3.1 Single-Byte Write

To start a write command, the master transmits an ST to the FXAS21002C, followed by the slave address with the R/W bit set to “0” for a write, and the FXAS21002C sends an ACK. Then, the master transmits the address of the register to write to, and the FXAS21002C sends an ACK. Then, the master transmits the 8-bit data to write to the designated register and the FXAS21002C sends an ACK that it has received the data. Since this transmission is complete, the master transmits an SP to end the data transfer. The data sent to the FXAS21002C is now stored in the appropriate register.

#### 3.1.3.2 Multiple-Byte Write

The FXAS21002C automatically increments the register address write pointer after a write command is received. Therefore, after following the steps of a single-byte write, multiple bytes of data can be written to sequential registers after each FXAS21002C ACK is received.



### 3.1.3.3 I<sup>2</sup>C Data Sequence Diagrams

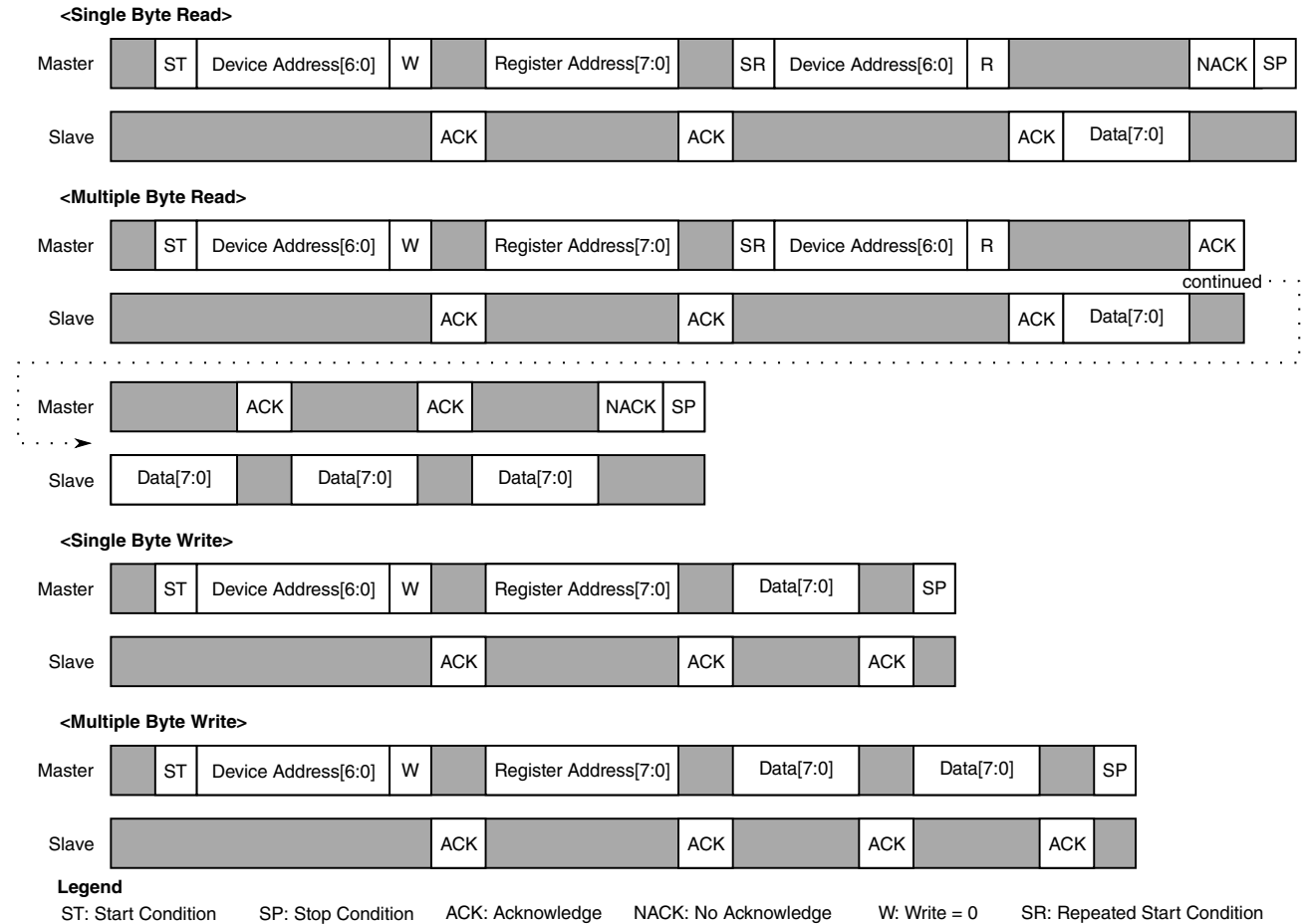


Figure 7. I<sup>2</sup>C data sequence diagram

## 3.2 SPI Interface

The SPI interface is a classical Master/Slave serial port. FXAS21002C is always considered to be the slave device and thus never initiates a communication with the host processor.

The SPI interface of FXAS21002C is compatible with SPI interface mode 00, corresponding to CPOL = 0 and CPHA = 0.

For CPOL = 0, the idle value of the clock is zero, and the active value of the clock is 1. For CPHA = 0, data is captured on the clock's rising edge (low to high transition) and data is propagated on the clock's falling edge (high to low transition).

### 3.2.1 General SPI Operation

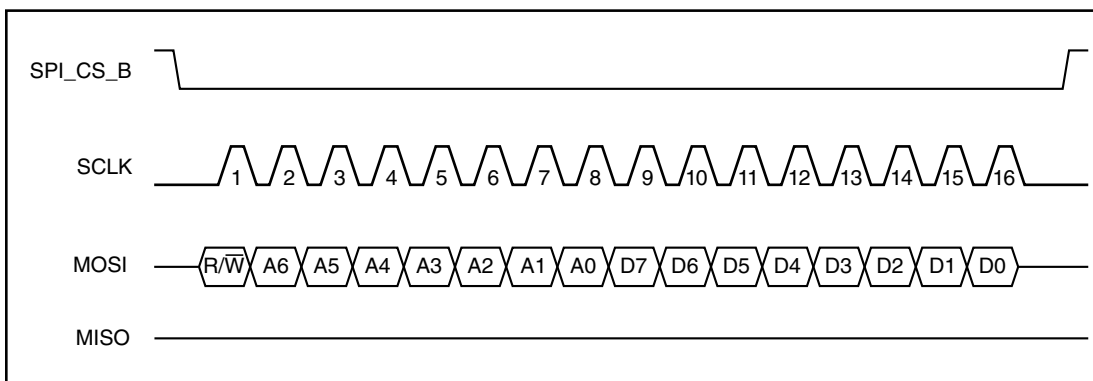
The SPI\_CS\_B pin is driven low at the start of a transaction, held low for the duration of the transfer, and then driven high again after the transaction is completed. During a transaction, the master toggles the clock (SCLK). The SCLK polarity is defined as having an idle value that is low, and an active phase that is high (CPOL = 0). Serial input and output data is captured on the clock's rising edge and propagated on the falling edge (CPHA = 0). Single byte read and single byte write operations are completed in 16 SCLK cycles; multiple byte reads and writes are completed in additional multiples of 8 SCLK cycles. The first SCLK cycle latches the most significant bit on MOSI to select whether the desired operation is a read (R/W = 1) or a write (R/W = 0). The following seven SCLK cycles are used to latch the slave register read or write address. The following seven SCLK cycles are used to latch the slave register read or write address.

#### NOTE

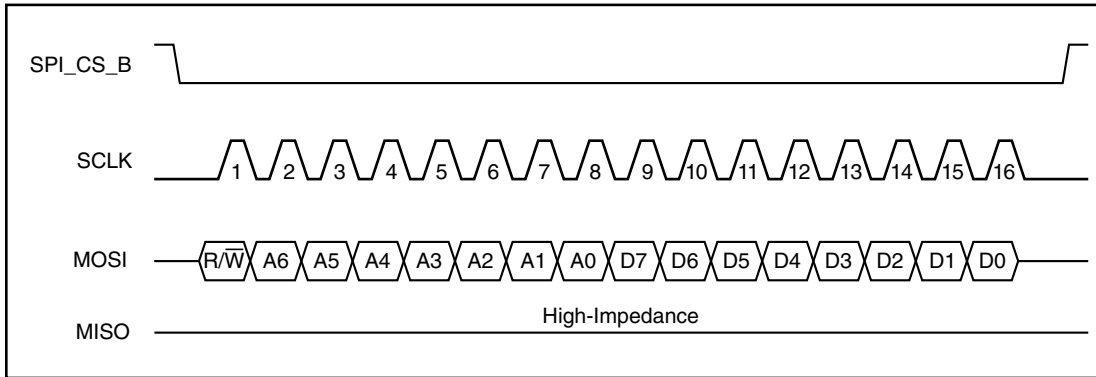
4-wire SPI interface mode is the default out of POR or after a hard/soft reset. The 3-wire interface mode may be selected by setting **CTRL\_REG0[SPIW] = 1**.

### 3.2.2 SPI Write Operations with 3- and 4-Wire Modes

A write operation is initiated by transmitting a 0 for the R/W bit. Then, the 7-bit register write address, A[6:0], is transmitted in MSb first order. The data byte to be written is then transferred during the second 8 SCLK cycle period (again, with MSb first). [Figure 8](#) and [Figure 9](#) shows the bus protocol for a single byte register write operation in either 3- or 4-wire SPI modes.

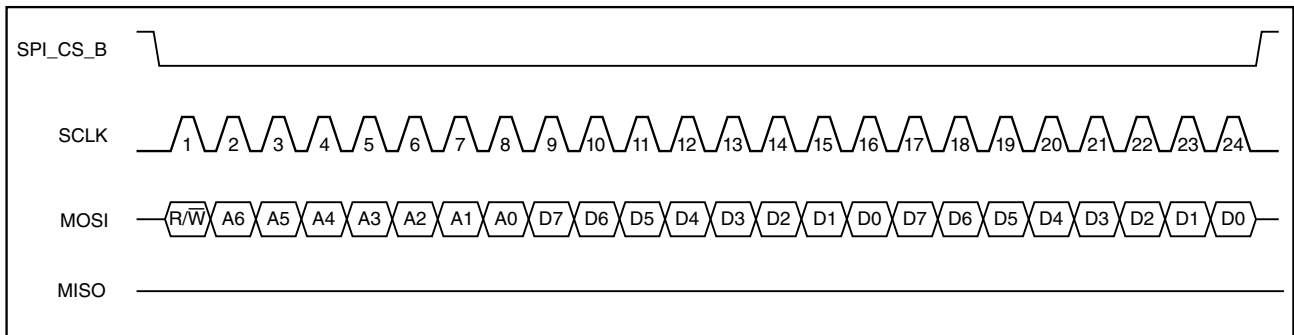


**Figure 8. SPI single byte write protocol diagram (4-wire mode), R/W = 0**

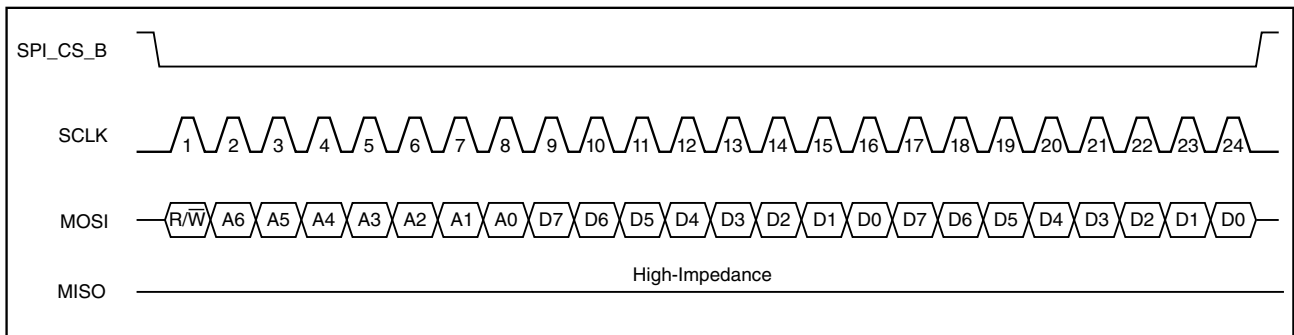


**Figure 9. SPI single byte write protocol diagram (3-wire mode), R/W = 0**

Multiple-byte write operations are performed similarly to the single-byte write sequence, but with additional data bytes transferred over every 8 SCLK cycle period. The register write address is internally auto-incremented by FXAS21002C so that every eighth clock edge will latch the address for the next register write address. When the desired number of bytes has been written, the rising edge on the SPI\_CS\_B pin terminates the transaction. [Figure 10](#) and [Figure 11](#) show the bus protocol for multiple byte register write operation in either 3- or 4-wire SPI modes.



**Figure 10. SPI multiple byte write protocol diagram (4-wire mode), R/W = 0**



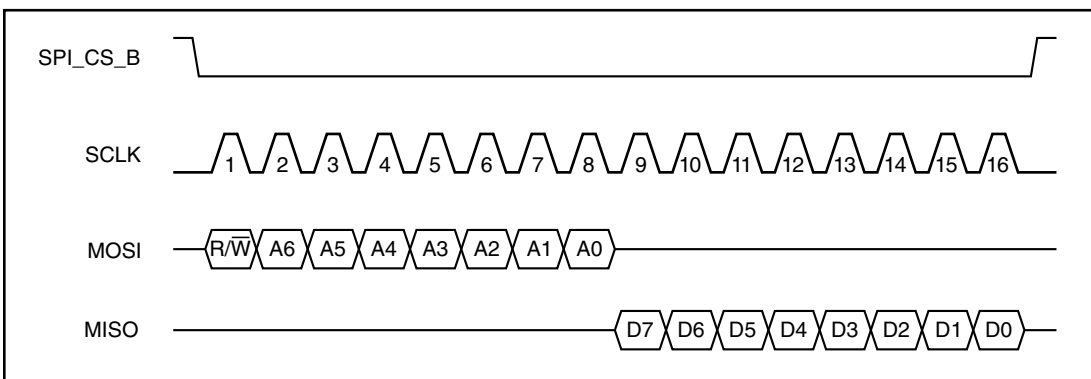
**Figure 11. SPI multiple byte write protocol diagram (3-wire mode), R/W = 0**

### 3.2.3 SPI Read Operations with 4-Wire Mode

#### NOTE

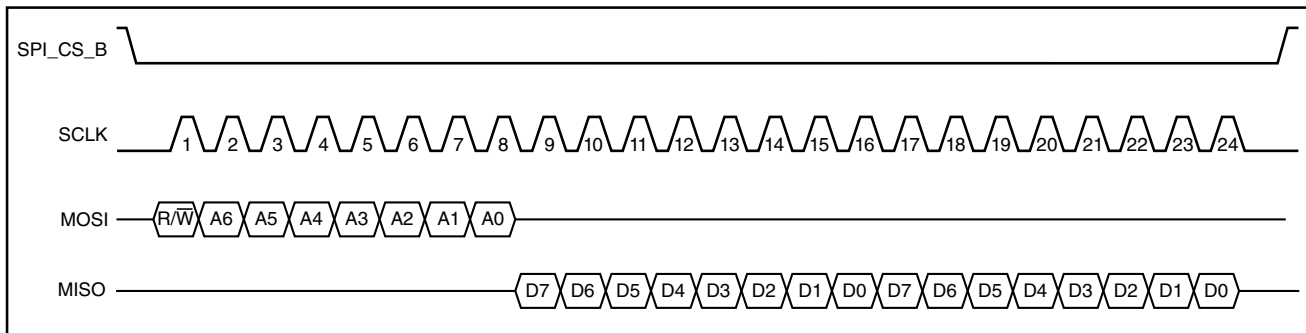
This description pertains only to the default SPI 4-wire interface mode (with CTRL\_REG0[SPIW] = 0). This mode is the default out of POR, or after a hard/soft reset.

A register read operation is initiated by transmitting a 1 for the R/W bit. Then, the 7-bit register read address, A[6:0] is encoded in the first byte. The data is read from the MISO pin (MSB first). [Figure 12](#) shows the bus protocol for a single byte read operation.



**Figure 12. SPI single byte read protocol diagram (4-wire mode), R/W = 1**

Multiple-byte read operations are performed similarly to single-byte reads; additional bytes are read in multiples of eight SCLK cycles. The register read address is auto-incremented by FXAS21002C so that every eighth clock edge will latch the address of the next register read address. When the desired number of bytes has been read, the rising edge on the SPI\_CS\_B terminates the transaction.



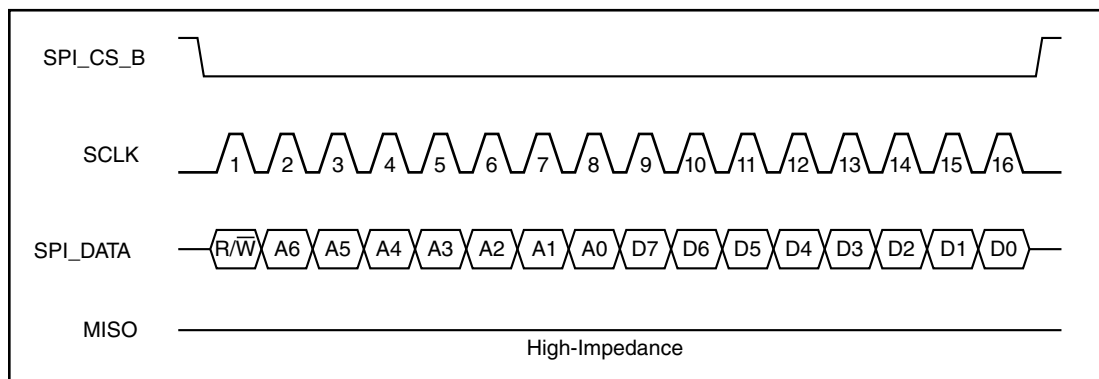
**Figure 13. SPI multiple byte read protocol diagram (4-wire mode), R/W = 1**

### 3.2.4 SPI Read Operations with 3-Wire Mode

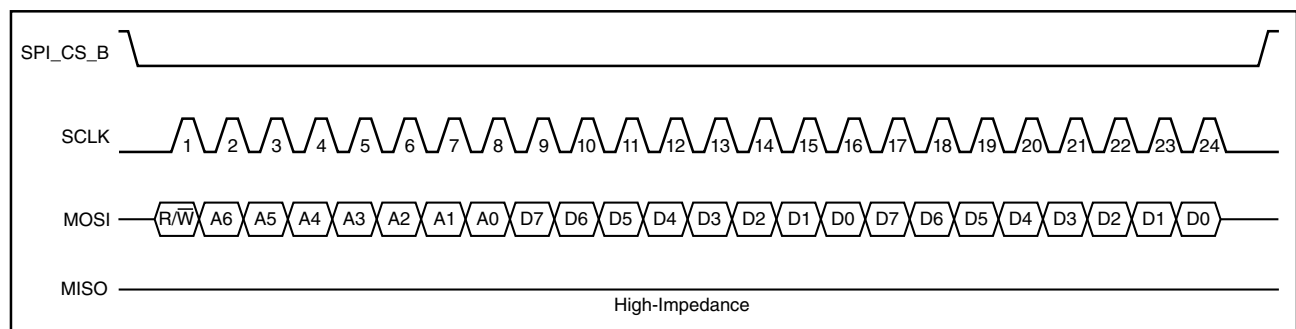
#### NOTE

This description pertains only to the 3-wire SPI interface mode (with **CTRL\_REG0[SPIW] = 1**). This interface mode is not the default and must be selected after a POR, or hard/soft reset.

FXAS21002C can be configured to operate in 3-wire SPI mode. In this mode the MISO pin is left unconnected or high-z, and the MOSI pin becomes a bi-directional input/output pin (SPI\_DATA). 3-wire mode is selected by setting the SPIW bit in **CTRL\_REG0**. Read operations in 3-wire mode are the same as in 4-wire mode except that at the end of address cycle, the MOSI (SPI\_DATA) pin automatically switches from an input to an output.



**Figure 14. SPI single byte read protocol diagram (3-wire mode)**



**Figure 15. SPI multiple byte read protocol diagram (3-wire mode)**

### 3.2.5 SPI Timing Specifications (4-wire mode)

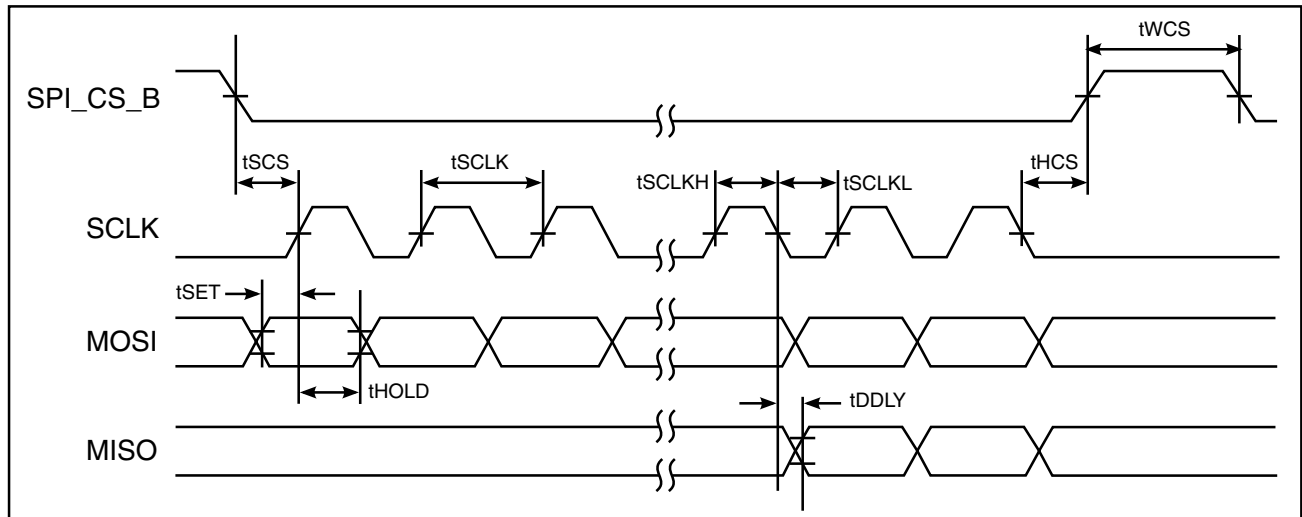
Table 11 and Figure 16 specify and illustrate the minimum and maximum timing parameter values for correct SPI interface functionality when FXAS21002C is operated in 4-wire SPI mode. The timing delays given in Table 11 are taken at 70% of the rising edge and 30% of the falling edge. FXAS21002C only supports SPI mode 00, corresponding to CPOL = 0, and CPHA = 0. In this mode, the active state of the clock is high and the idle state is low. Data is latched on the rising edge of the clock and propagated on the falling edge. Please note that the timing parameters shown in Table 11 are based on simulations performed across process, voltage, and temperature with a total bus capacitance of 80 pF and a 10 kΩ pull-up resistor to VDDIO on each SPI interface pin (SCL/SCLK, SDA/MOSI/SPI\_DATA, SA0/MISO, and SPI\_CS\_B).

#### NOTE

In 4-wire SPI mode the MISO pin is always placed in a high impedance state when CS\_B is not asserted (logic high level).

**Table 11. Slave timing values**

| Label  | Description   | Specifications |      | Unit |
|--------|---|----------------|------|------|
|        |   | Min.           | Max. |      |
| fSCLK  | SCLK frequency  | 0              | 2    | MHz  |
| tSCLK  | SCLK Period   | 500            | —    | ns   |
| tSCLKH | SCLK high time  | 210            | —    | ns   |
| tSCLKL | SCLK low time   | 210            | —    | ns   |
| tSZ    | Setup time for MISO signal (transition out of high-z state) | —              | 130  |      |
| tHZ    | Hold time for MISO signal (transition back to high-z state) | —              | 110  |      |
| tSCS   | Setup time for SPI_CS_B signal                              | 250            | —    | ns   |
| tHCS   | Hold time for SPI_CS_B signal                               | 200            | —    | ns   |
| tWCS   | Inactive time for SPI_CS_B signal                           | 110            | —    | ns   |
| tSET   | Data setup time for MOSI signal                             | 20             | —    | ns   |
| tHOLD  | Data hold time for MOSI signal                              | 200            | —    | ns   |
| tDDL   | Data setup time for MISO signal                             | —              | 210  | ns   |



**Figure 16. SPI timing diagram (4-wire mode)**

### 3.2.6 SPI Timing Specifications (3-wire mode)

Table 12 and Figure 17 specify and illustrate the minimum and maximum timing parameter values for correct SPI interface functionality when FXAS21002C is operated in 3-wire SPI mode. The timing delays given in Table 12 are taken at 70% of the rising edge and 30% of the falling edge. FXAS21002C only supports SPI mode '00', corresponding to CPOL = 0, and CPHA = 0. In this mode, the active state of the clock is high and the idle state is low. Data is latched on the rising edge of the clock and propagated on the falling edge. Please note that the timing parameters shown in Table 12 are based on simulations performed across process, voltage, and temperature with a total bus capacitance of 80pF and a 10 kΩ pull-up resistor to VDDIO on each SPI interface pin (SCL/SCLK, SDA/MOSI/SPI\_DATA, SA0/MISO, and SPI\_CS\_B).

#### NOTE

When FXAS21002C is operated in 3-wire SPI mode - by setting CTRL\_REG0[SPIW] = 1 - the SA0/MISO pin is always placed in a high impedance (high-z) state.

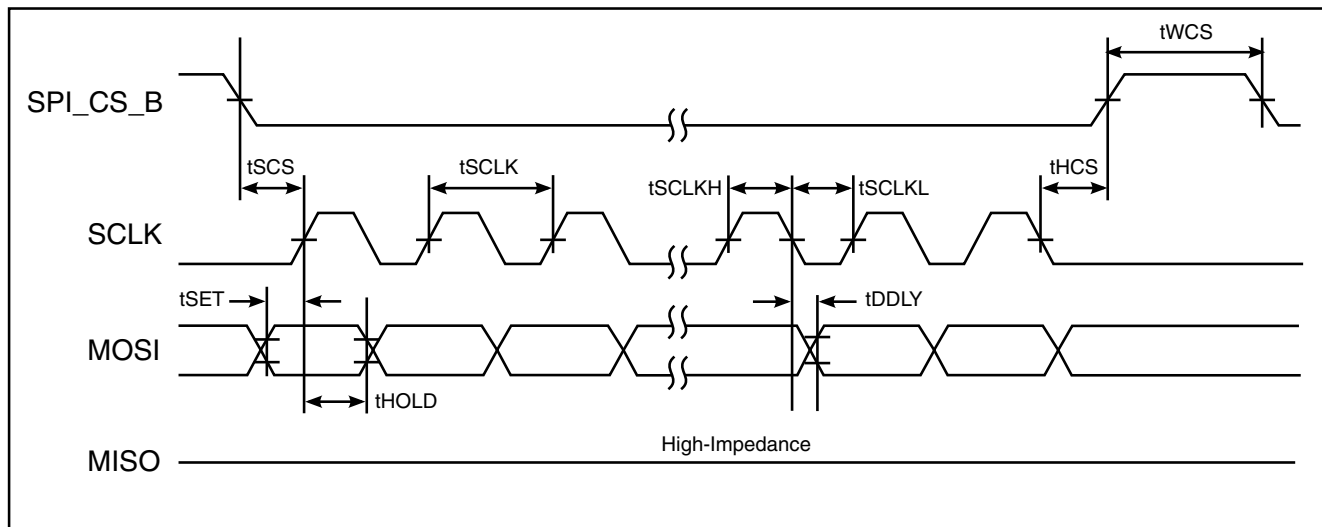
**Table 12. Slave timing values**

| Label  | Description    | Specifications |      | Unit |
|--------|----------------|----------------|------|------|
|        |                | Min.           | Max. |      |
| fSCLK  | SCLK frequency | 0              | 1.4  | MHz  |
| tSCLK  | SCLK Period    | 714            | —    | ns   |
| tSCLKH | SCLK high time | 300            | —    | ns   |

*Table continues on the next page...*

**Table 12. Slave timing values (continued)**

| Label  | Description   | Specifications |      | Unit |
|--------|---|----------------|------|------|
|        |   | Min.           | Max. |      |
| tSCLKL | SCLK low time   | 300            | —    | ns   |
| tHZ    | Hold time for MISO signal (transition back to high-z state) | —              | 200  |      |
| tSCS   | Setup time for SPI_CS_B signal                              | 250            | —    | ns   |
| tHCS   | Hold time for SPI_CS_B signal                               | 200            | —    | ns   |
| tWCS   | Inactive time for SPI_CS_B signal                           | 200            | —    | ns   |
| tSET   | Data setup time for MOSI signal                             | 20             | —    | ns   |
| tHOLD  | Data hold time for MOSI signal                              | 200            | —    | ns   |
| tDDLY  | Data setup time for MISO signal                             | —              | 280  | ns   |



**Figure 17. SPI timing diagram (3-wire mode)**

## 4 Modes of Operation

The device may be placed into one of three functional modes:

- **Standby:** Some digital blocks are enabled; I<sup>2</sup>C/SPI communication is possible. This mode is the minimum power consumption state for the device and is the default mode entered on POR or hard/soft reset. A transition from Standby mode to Active mode takes 1/ODR + 60 ms, typical.

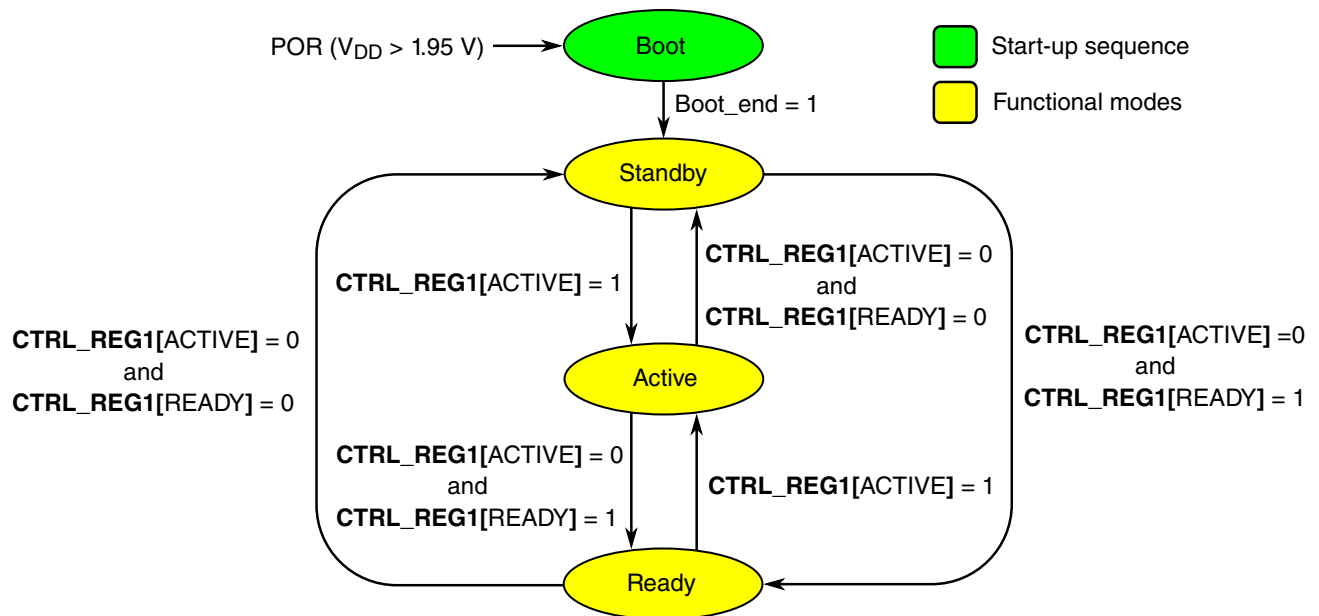


- **Active:** All blocks are enabled (digital and analog); the device is actively measuring the angular rate at the ODR specified in **0x13: CTRL\_REG1**. This is the maximum power consumption state of the device.
- **Ready:** This mode is entered by setting **CTRL\_REG1[Ready] = 1**. In this mode, the drive circuits are running but no measurements are being made. This mode offers the user the ability to significantly reduce the current draw of the device while providing a fast transition into Active mode within  $1/ODR + 5$  ms.

**NOTE**

When **CTRL\_REG3[EXTCTRLLEN] = 0**, the Active mode is entered/exited using the register interface (**CTRL\_REG1[ACTIVE]** bit). When **CTRL\_REG3[EXTCTRLLEN] = 1**, the Active mode is entered/exited via the logic state on the PWR\_CTRL input pin (pin 2).

The functional mode is selected using CTRL\_REG1. After a POR (Power on Reset), a boot sequence is performed by the device and the registers are loaded with their preset values. After the boot sequence completes, the default operating mode of FXAS21002C is Standby mode.



**Figure 18. Functional mode transition diagram with CTRL\_REG3[EXTCTRLLEN] = 0**

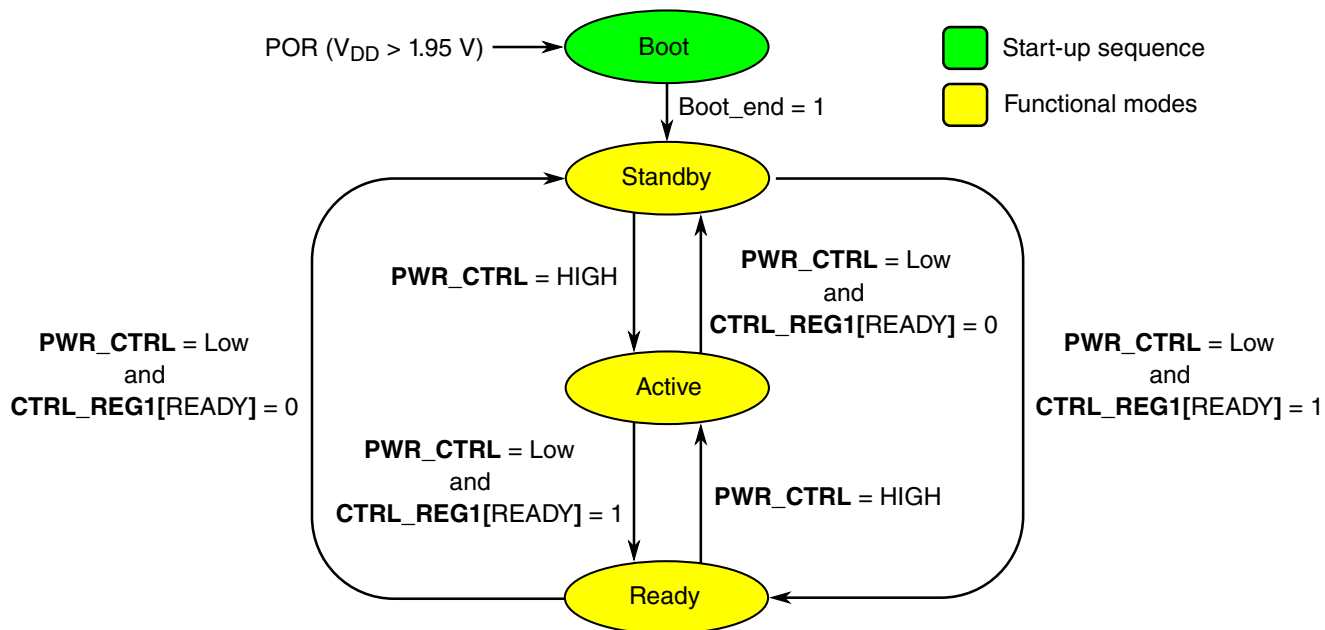


Figure 19. Functional mode transition diagram with  $\text{CTRL\_REG3}[\text{EXTCTRLLEN}] = 1$

## 5 Functionality

The FXAS21002C is a low-power, digital-output, 3-axis gyroscope with both I<sup>2</sup>C and SPI interfaces. The functionality includes the following:

- 16-bit output data presented in 2's complement format
- Configurable full scale ranges of  $\pm 250$ ,  $\pm 500$ ,  $\pm 1000$  and  $\pm 2000$  dps; optional FSRs of  $\pm 500$ ,  $\pm 1000$ ,  $\pm 2000$  and  $\pm 4000$  by setting  $\text{CTRL\_REG3}[\text{FS\_DOUBLE}] = 1$
- Configurable output data rates from 12.5 to 800 Hz
- Internal low-pass filter with programmable cut-off frequency to limit the output data bandwidth
- Angular rate sensitivity of  $0.0625^\circ/\text{s}$  in  $\pm 2000^\circ/\text{s}$  FSR mode
- Internal high-pass filter with programmable cut-off frequency
- Embedded rate threshold detection function with programmable debounce time
- 32-sample FIFO configurable in Circular or Stop data collection modes
- 2 external interrupt pins that are configurable to signal data-ready, Rate Threshold or FIFO events
- Self-test function for indication of device health

Data for each axis must be read from the respective data registers, two bytes at a time; for example, one byte for most significant byte and one byte for least significant. Combining these two bytes results in a 16-bit 2's complement signed integer with the sign bit in bit location #15 and the least significant bit in location 0. See the tables below:

|          |            |     |     |     |     |     |    |    |
|----------|------------|-----|-----|-----|-----|-----|----|----|
| Bit      | <b>15</b>  | 14  | 13  | 12  | 11  | 10  | 9  | 8  |
| Data bit | <b>D15</b> | D14 | D13 | D12 | D11 | D10 | D9 | D8 |

**Sign bit**

|          |    |    |    |    |    |    |    |           |
|----------|----|----|----|----|----|----|----|-----------|
| Bit      | 7  | 6  | 5  | 4  | 3  | 2  | 1  | <b>0</b>  |
| Data bit | D7 | D6 | D5 | D4 | D3 | D2 | D1 | <b>D0</b> |

**LSB**

The conversion from counts to units of dps is done by first adjusting the byte order of the output data (if needed). On a big-endian processor, no byte order changes are needed. On a little-endian processor, the byte order (MSB, LSB) must be swapped. Following this step, the 16-bit value is multiplied by the appropriate sensitivity value for the selected full scale range. See [Table 35](#) for nominal sensitivity values.

## 5.1 FIFO Data Buffer

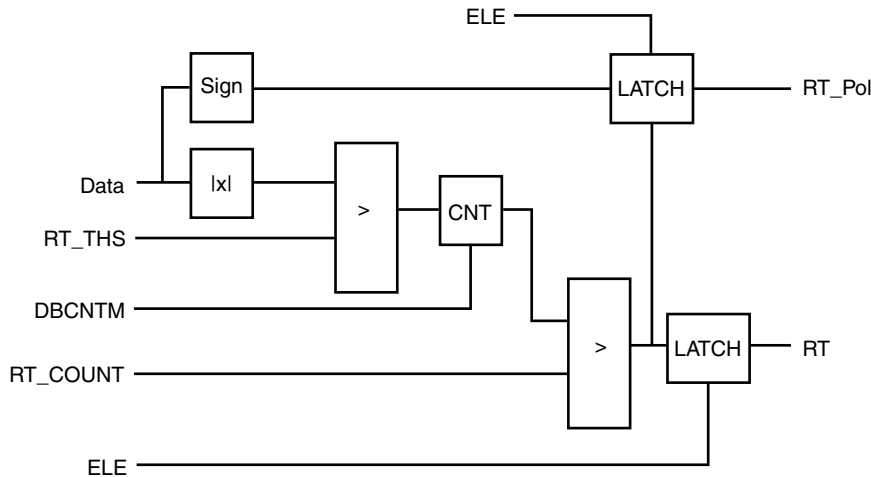
FXAS21002C contains a FIFO data buffer that is 192 bytes (32 X/Y/Z samples) and is useful for reducing the frequency of transactions on the I<sup>2</sup>C/SPI bus. The FIFO can also provide system level power savings by allowing the host processor/MCU to go into a sleep/low-power mode while the FXAS21002C collects up to 32 samples of 3-axis angular rate data.

The FIFO is configured to operate in Circular Buffer mode or Stop mode, depending on the settings made in the [0x09: F\\_SETUP](#) register. The Circular Buffer mode allows the FIFO to be filled with a new sample, replacing the oldest sample in the buffer. The most recent 32 samples will be stored in the buffer. This is useful in situations where the processor is waiting for a specific interrupt to indicate that the data must be flushed to analyze the event.

The FXAS21002C FIFO Buffer has a configurable watermark, allowing an interrupt to be signaled to the processor after a configurable number of samples enter the buffer (1 to 32).

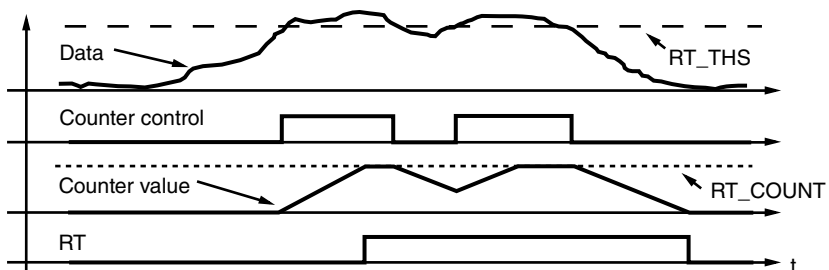
## 5.2 Rate Threshold Detection Function

The embedded rate detection function can be used to detect an angular rate event that exceeds a programmed threshold on any one of the enabled axes for longer than the programmed debounce time, triggering an interrupt on one of the INT1/INT2 pins (if enabled).

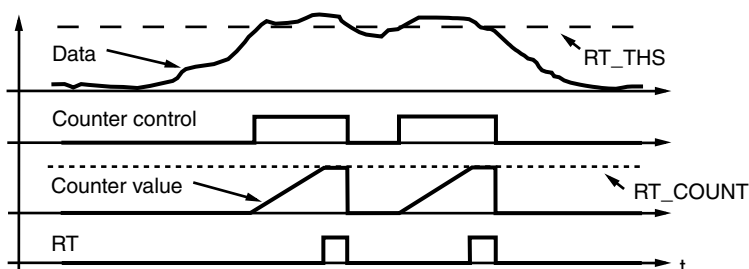


| Output data rate (Hz) | ODR and counter clock period (ms) | Event debounce time range (s) |
|-----------------------|-----------------------------------|-------------------------------|
| 800                   | 1.25                              | 0 – 0.32                      |
| 400                   | 2.5                               | 0 – 0.64                      |
| 200                   | 5                                 | 0 – 1.28                      |
| 100                   | 10                                | 0 – 2.56                      |
| 50                    | 20                                | 0 – 5.12                      |
| 25                    | 40                                | 0 – 10.24                     |
| 12.5                  | 80                                | 0 – 20.48                     |

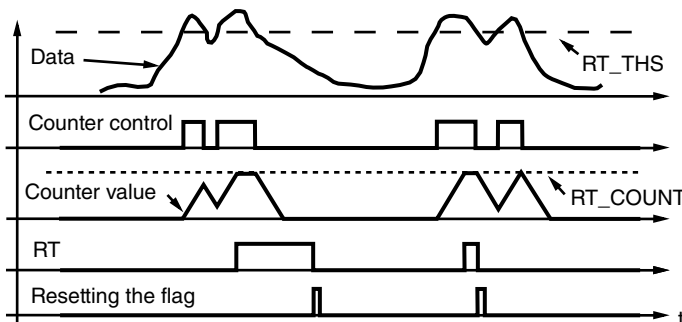
If the debounce counter reaches the value stored in **RT\_COUNT**, the rate threshold event is detected. The interrupt flag can be either latched or updated in real-time depending on the state of the **ELE** bit. The examples illustrated in [Figure 20](#) through [Figure 23](#) show the use of the rate threshold function with the various settings for the **DBCNTM** and **ELE** control bits:



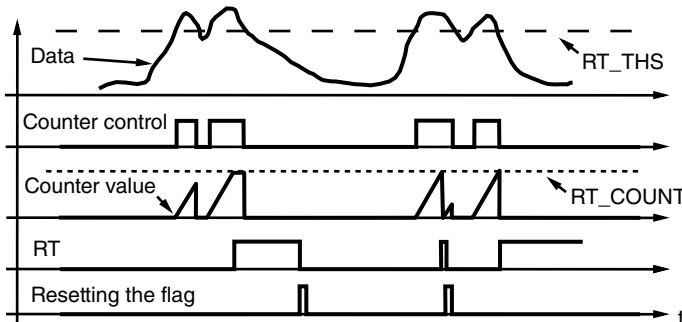
**Figure 20. ELE = 0 and DBCNTM = 0**



**Figure 21. ELE = 0 and DBCNTM = 1**



**Figure 22. ELE = 1 and DBCNTM = 0**



**Figure 23. ELE = 1 and DBCNTM = 1**

## 6 Register Descriptions

**Table 13. Register address map**

| Name         | Type | Register address | Auto-increment address | Default value     | Comment  |
|--------------|------|------------------|------------------------|-------------------|--|
| STATUS       | R    | 0x00             | 0x01                   | 0x00              | Alias for DR_STATUS or F_STATUS  |
| OUT_X_MSB    | R    | 0x01             | 0x02                   | 0x00 <sup>1</sup> | [7:0] are 8 MSBs of 16 bit X-axis data sample  |
| OUT_X_LSB    | R    | 0x02             | 0x03                   | 0x00 <sup>1</sup> | [7:0] are 8 MSBs of 16 bit X-axis data sample  |
| OUT_Y_MSB    | R    | 0x03             | 0x04                   | 0x00 <sup>1</sup> | [7:0] are 8 MSBs of 16 bit Y-axis data sample  |
| OUT_Y_LSB    | R    | 0x04             | 0x05                   | 0x00 <sup>1</sup> | [7:0] are 8 MSBs of 16 bit Y-axis data sample  |
| OUT_Z_MSB    | R    | 0x05             | 0x06                   | 0x00 <sup>1</sup> | [7:0] are 8 MSBs of 16 bit Z-axis data sample  |
| OUT_Z_LSB    | R    | 0x06             | 0x00/0x01              | 0x00 <sup>1</sup> | [7:0] are 8 MSBs of 16 bit Z-axis data sample; Auto-increment address depends on the setting made in CTRL_REG3[WRAPTOONE] (defaults to 0x00) |
| DR_STATUS    | R    | 0x07             | 0x08                   | 0x00              | Data-ready status information  |
| F_STATUS     | R    | 0x08             | 0x09                   | 0x00              | FIFO Status  |
| F_SETUP      | R/W  | 0x09             | 0x0A                   | 0x00              | FIFO setup   |
| F_EVENT      | R    | 0x0A             | 0x0B                   | 0x00              | FIFO event   |
| INT_SRC_FLAG | R    | 0x0B             | 0x0C                   | 0x00              | Interrupt event source status flags  |
| WHO_AM_I     | R    | 0x0C             | 0x0D                   | 0xD7              | Device ID  |
| CTRL_REG0    | R/W  | 0x0D             | 0x0E                   | 0x00              | Control register 0: Full-scale range selection, high-pass filter setting, SPI mode selection   |
| RT_CFG       | R/W  | 0x0E             | 0x0F                   | 0x00              | Rate threshold function configuration  |
| RT_SRC       | R    | 0x0F             | 0x10                   | 0x00              | Rate threshold event flags status register   |
| RT_THS       | R/W  | 0x10             | 0x11                   | 0x00              | Rate threshold function threshold register   |
| RT_COUNT     | R/W  | 0x11             | 0x12                   | 0x01              | Rate threshold function debounce counter   |
| TEMP         | R    | 0x12             | 0x13                   | 0x00              | Device temperature in °C   |
| CTRL_REG1    | R/W  | 0x13             | 0x14                   | 0x00              | Control register 1: Operating mode, ODR selection, self-test and soft reset  |
| CTRL_REG2    | R/W  | 0x14             | 0x15                   | 0x00              | Control register 2: Interrupt configuration settings   |
| CTRL_REG3    | R/W  | 0x15             | 0x00                   | 0x00              | Control Register 3: Auto-increment address configuration, external power control, FSR expansion  |
| RESERVED     | —    | 0x16 – 0xFF      | address + 1            | —                 | Factory reserved register space  |

1. As shown on POR. On hard/soft reset, the default value cannot be determined.

## 6.1 0x00: STATUS

The STATUS register content depends on the FIFO mode setting. It is a copy of either [0x07: DR\\_STATUS](#) or [0x08: F\\_STATUS](#). This allows for easy reading of the relevant status register before reading the current sample output data, or the first sample stored in the FIFO.

## 6.2 0x01–0x06: OUT\_X\_MSB, OUT\_X\_LSB, OUT\_Y\_MSB, OUT\_Y\_LSB, OUT\_Z\_MSB, OUT\_Z\_LSB

The X-axis, Y-axis, and Z-axis output rate data are represented in 16-bit, 2's complement format. The output data registers are arranged in a contiguous big endian format, with the MSB of each axis's data located at the lower register address. The output data registers are either updated at the selected output data rate (with **F\_SETUP[F\_MODE]** equal to 0b00), or alternately, point to the head of the FIFO buffer (with **F\_SETUP[F\_MODE]** greater than 0b00). When reading a data sample with **F\_MODE** equal to 0b00, the host must always start by reading the MSB of each axis first to ensure that the corresponding LSB register is also updated with the current sample data. When **F\_MODE** is greater than 0b00, the **OUT\_X\_MSB** register must be read out first in order for the other five output data registers (**OUT\_X\_LSB** through **OUT\_Z\_LSB**) to be updated with sample data stored at the head of the FIFO. The FIFO head pointer is only incremented to point to the next stored sample when the host reads the **OUT\_Z\_MSB** register.

### NOTE

To avoid the loss of data, the user must burst-read all six bytes of sample data (three axes) in a single I<sup>2</sup>C or SPI transaction.

**Table 14. 0x01: OUT\_X\_MSB**

| Bit                | 7        | 6 | 5 | 4 | 3 | 2 | 1 | 0 |
|--------------------|----------|---|---|---|---|---|---|---|
| Read               | XD[15:8] |   |   |   |   |   |   |   |
| Write              |          |   |   |   |   |   |   |   |
| Reset <sup>1</sup> | 0        | 0 | 0 | 0 | 0 | 0 | 0 | 0 |

1. As shown on POR. On hard/soft reset, the default value cannot be determined.

**Table 15. 0x02: OUT\_X\_LSB**

| Bit                | 7       | 6 | 5 | 4 | 3 | 2 | 1 | 0 |
|--------------------|---------|---|---|---|---|---|---|---|
| Read               | XD[7:0] |   |   |   |   |   |   |   |
| Write              |         |   |   |   |   |   |   |   |
| Reset <sup>1</sup> | 0       | 0 | 0 | 0 | 0 | 0 | 0 |   |

1. As shown on POR. On hard/soft reset, the default value cannot be determined.

**Table 16. 0x03: OUT\_Y\_MSB**

| Bit                | 7        | 6 | 5 | 4 | 3 | 2 | 1 | 0 |
|--------------------|----------|---|---|---|---|---|---|---|
| Read               | YD[15:8] |   |   |   |   |   |   |   |
| Write              |          |   |   |   |   |   |   |   |
| Reset <sup>1</sup> | 0        | 0 | 0 | 0 | 0 | 0 | 0 | 0 |

1. As shown on POR. On hard/soft reset, the default value cannot be determined.

**Table 17. 0x04: OUT\_Y\_LSB**

| Bit                | 7       | 6 | 5 | 4 | 3 | 2 | 1 | 0 |
|--------------------|---------|---|---|---|---|---|---|---|
| Read               | YD[7:0] |   |   |   |   |   |   |   |
| Write              |         |   |   |   |   |   |   |   |
| Reset <sup>1</sup> | 0       | 0 | 0 | 0 | 0 | 0 | 0 | 0 |

1. As shown on POR. On hard/soft reset, the default value cannot be determined.

**Table 18. 0x05: OUT\_Z\_MSB**

| Bit                | 7        | 6 | 5 | 4 | 3 | 2 | 1 | 0 |
|--------------------|----------|---|---|---|---|---|---|---|
| Read               | ZD[15:8] |   |   |   |   |   |   |   |
| Write              |          |   |   |   |   |   |   |   |
| Reset <sup>1</sup> | 0        | 0 | 0 | 0 | 0 | 0 | 0 | 0 |

1. As shown on POR. On hard/soft reset, the default value cannot be determined.

**Table 19. 0x06: OUT\_Z\_LSB**

| Bit                | 7       | 6 | 5 | 4 | 3 | 2 | 1 | 0 |
|--------------------|---------|---|---|---|---|---|---|---|
| Read               | ZD[7:0] |   |   |   |   |   |   |   |
| Write              |         |   |   |   |   |   |   |   |
| Reset <sup>1</sup> | 0       | 0 | 0 | 0 | 0 | 0 | 0 | 0 |

1. As shown on POR. On hard/soft reset, the default value cannot be determined.



## NOTE

After this register is read, the next read register by the auto-increment process is STATUS at 0x00, when CTRL\_REG3[WRAPTOONE] = 0, or OUT\_X\_MSB when CTRL\_REG3[WRAPTOONE] = 1.

Data output LSB registers only contain valid data after a read of the corresponding axis MSB data register. When F\_SETUP[F\_MODE] > 0b00, a data read operation must start by reading the OUT\_X\_MSB register in order for the contents of the other output data registers to be updated for the currently indexed buffered sample. With F\_SETUP[F\_MODE] > 0b00, the OUT\_Z\_MSB register must be read in order to advance the internal buffer read pointer to index the next sample stored in the FIFO.

### 6.3 0x07: DR\_STATUS

The DR\_STATUS register provides the sample data acquisition status and reflects the real-time updates to the OUT\_X, OUT\_Y, and OUT\_Z registers. The content of this register is reset upon a transition from Standby to Active or from Ready to Active modes.

**Table 20. DR\_STATUS register**

| Bit   | 7     | 6   | 5   | 4   | 3     | 2   | 1   | 0   |
|-------|-------|-----|-----|-----|-------|-----|-----|-----|
| Read  | ZYXOW | ZOW | YOW | XOW | ZYXDR | ZDR | YDR | XDR |
| Write |       |     |     |     |       |     |     |     |
| Reset | 0     | 0   | 0   | 0   | 0     | 0   | 0   | 0   |

**Table 21. DR\_STATUS field descriptions**

| Field      | Description  |
|------------|--|
| 7<br>ZYXOW | X-, Y-, Z-axis data overwrite <ul style="list-style-type: none"> <li>Asserted whenever new X-, Y-, and Z-axis data is acquired before completing the retrieval of the previous set.</li> <li>Cleared after the high-bytes of the data of all channels (OUT_X_MSB, OUT_Y_MSB, OUT_Z_MSB) are read.</li> </ul> 0: No data overwrite has occurred<br>1: X, Y, and Z data overwrite occurred before the previous data was read |

*Table continues on the next page...*

**Table 21. DR\_STATUS field descriptions (continued)**

| Field      | Description   |
|------------|---|
| 6<br>ZOW   | <p>Z-axis data overwrite</p> <ul style="list-style-type: none"> <li>Asserted whenever a new Z-axis acquisition is completed before the retrieval of the previous data. When this occurs, the previous data is overwritten.</li> <li>Cleared anytime the OUT_Z_MSB (and respectively OUT_Y_MSB, OUT_X_MSB) register is read.</li> </ul> <p>0: No data overwrite has occurred<br/>1: Z-axis data overwrite occurred before the previous data was read</p> |
| 5<br>YOW   | <p>Y-axis data overwrite</p> <ul style="list-style-type: none"> <li>Asserted whenever a new Y-axis acquisition is completed before the retrieval of the previous data. When this occurs, the previous data is overwritten.</li> <li>Cleared anytime the OUT_Z_MSB (and respectively OUT_Y_MSB, OUT_X_MSB) register is read.</li> </ul> <p>0: No data overwrite has occurred<br/>1: Y-axis data overwrite occurred before the previous data was read</p> |
| 4<br>XOW   | <p>X-axis data overwrite</p> <ul style="list-style-type: none"> <li>Asserted whenever a new X-axis acquisition is completed before the retrieval of the previous data. When this occurs, the previous data is overwritten.</li> <li>Cleared anytime the OUT_Z_MSB (and respectively OUT_Y_MSB, OUT_X_MSB) register is read.</li> </ul> <p>0: No data overwrite has occurred<br/>1: X-axis data overwrite occurred before the previous data was read</p> |
| 3<br>ZYXDR | <p>X-, Y-, and Z-axis data available</p> <ul style="list-style-type: none"> <li>Signals that a new acquisition for any of the channels is available.</li> <li>Cleared when the high-bytes of the data of all channels (OUT_X_MSB, OUT_Y_MSB, OUT_Z_MSB) are read.</li> </ul> <p>0: No new data is ready<br/>1: New data is ready</p>  |
| 2<br>ZDR   | <p>Z-axis new data available</p> <ul style="list-style-type: none"> <li>Asserted whenever a new Z-axis data acquisition is completed.</li> <li>Cleared anytime the OUT_Z_MSB register is read.</li> </ul> <p>0: No new Z-axis data is ready<br/>1: New Z-axis data is ready</p>   |
| 1<br>YDR   | <p>Y-axis new data available</p> <ul style="list-style-type: none"> <li>Asserted whenever a new Y-axis data acquisition is completed.</li> <li>Cleared anytime the OUT_Y_MSB register is read.</li> </ul> <p>0: No new Y-axis data is ready<br/>1: New Y-axis data is ready</p>   |
| 0<br>XDR   | <p>X-axis new data available</p> <ul style="list-style-type: none"> <li>Asserted whenever a new X-axis data acquisition is completed.</li> <li>Cleared anytime the OUT_X_MSB register is read.</li> </ul> <p>0: No new X-axis data is ready<br/>1: New X-axis data is ready</p>   |

## 6.4 0x08: F\_STATUS

When the FIFO is enabled, the F\_STATUS register indicates the current status of the FIFO. Also, the STATUS register (address 0x00) contains the same content as F\_STATUS to facilitate the emptying of the FIFO by the host processor. The content of this register is reset upon a transition from Standby to Active or from Ready to Active modes.

**Table 22. F\_STATUS register**

| Bit   | 7     | 6      | 5          | 4 | 3 | 2 | 1 | 0 |
|-------|-------|--------|------------|---|---|---|---|---|
| Read  | F_OVF | F_WMKF | F_CNT[5:0] |   |   |   |   |   |
| Write |       |        |            |   |   |   |   |   |
| Reset | 0     | 0      | 0          | 0 | 0 | 0 | 0 | 0 |

**Table 23. F\_Status field descriptions**

| Field        | Description  |
|--------------|--|
| 7<br>F_OVF   | FIFO overflow flag <ul style="list-style-type: none"> <li>A FIFO overflow event, such as when F_CNT = 32 and a new sample arrives, asserts the F_OVF flag.</li> <li>Cleared when the FIFO sample count goes below 32.</li> </ul> 0: No overflow detected<br>1: Overflow detected   |
| 6<br>F_WMKF  | FIFO watermark flag <ul style="list-style-type: none"> <li>A FIFO sample count greater than or equal to the sample count watermark (determined by the F_WMRK field in register 0x09: F_SETUP) asserts the F_WMKF event flag.</li> <li>Cleared when FIFO sample count goes below the sample count watermark (set by the value of F_SETUP[F_WMRK] field).</li> </ul> 0: No watermark event detected<br>1: Watermark event detected |
| 5:0<br>F_CNT | FIFO sample counter <ul style="list-style-type: none"> <li>Indicates the number of samples currently stored in the FIFO.</li> <li>A count value of 0b000000 indicates that the FIFO is empty.</li> </ul>   |

## 6.5 0x09: F\_SETUP

The F\_SETUP register is used to configure the FIFO. The FIFO update rate is set by the selected system ODR (DR bits in 0x13: CTRL\_REG1). The contents should be modified only when the device is in Standby mode.

**Table 24. F\_Setup register**

|       |             |   |             |   |   |   |   |   |
|-------|-------------|---|-------------|---|---|---|---|---|
| Bit   | 7           | 6 | 5           | 4 | 3 | 2 | 1 | 0 |
| Read  | F_MODE[1:0] |   | F_WMRK[5:0] |   |   |   |   |   |
| Write | F_MODE[1:0] |   | F_WMRK[5:0] |   |   |   |   |   |
| Reset | 0           | 0 | 0           | 0 | 0 | 0 | 0 | 0 |

**Table 25. F\_SETUP field descriptions**

| Field         | Description   |
|---------------|---|
| 7:6<br>F_MODE | <p>FIFO operating mode selection:</p> <p>00: FIFO is disabled</p> <p>01: Circular Buffer mode</p> <p>1x: Stop mode</p> <p>Note:</p> <ul style="list-style-type: none"> <li>Used to select the FIFO operating mode.</li> <li>In the Circular Buffer mode, the oldest sample is discarded and replaced by the newest sample when the buffer is full with <b>F_STATUS[F_CNT] = 32</b>.</li> <li>In the Stop mode, the FIFO will stop accepting new samples when the buffer is full with <b>F_STATUS[F_CNT] = 32</b>.</li> <li>The FIFO operating mode cannot be switched between Circular and Stop modes while the FIFO is enabled.</li> <li>To change the FIFO operating mode, the FIFO function must first be disabled by setting F_MODE[1:0] = 00.</li> <li>The FIFO is cleared whenever the FIFO is disabled.</li> </ul> |
| 5:0<br>F_WMRK | <p>FIFO sample count watermark setting</p> <ul style="list-style-type: none"> <li>Used to set the watermark level.</li> <li>To suppress FIFO watermark event flag generation, F_WMRK[5:0] can be set to 0x00.</li> <li>Disabling the FIFO clears F_WMKF</li> <li>A FIFO sample count exceeding the watermark level does not stop the FIFO from accepting new data.</li> </ul> <p>Default value is 0b000000.</p>   |

## 6.6 0x0A: F\_EVENT

The F\_EVENT register is used to monitor the FIFO event status. The content of this register is reset upon a transition from Standby to Active or from Ready to Active modes.

**Table 26. F\_Event register**

|       |   |   |         |              |   |   |   |   |
|-------|---|---|---------|--------------|---|---|---|---|
| Bit   | 7 | 6 | 5       | 4            | 3 | 2 | 1 | 0 |
| Read  | 0 | 0 | F_EVENT | FE_TIME[4:0] |   |   |   |   |
| Write |   |   |         |              |   |   |   |   |
| Reset | 0 | 0 | 0       | 0            | 0 | 0 | 0 | 0 |

**Table 27. F\_EVENT field descriptions**

| Field          | Description   |
|----------------|---|
| 5<br>F_EVENT   | FIFO Event <ul style="list-style-type: none"> <li>Indicates if either <b>F_OVF</b> or <b>F_WMKF</b> flags are set (logical OR).</li> <li>The <b>F_STATUS</b> register must be read to determine which event(s) occurred.</li> <li>To clear this flag, both <b>F_OVF</b> and <b>F_WMKF</b> flags must be cleared. See <b>F_STATUS</b> for details.</li> </ul> 0: FIFO Event not detected<br>1: FIFO Event was detected |
| 4:0<br>FE_TIME | Number of ODR periods elapsed since F_EVENT was set <ul style="list-style-type: none"> <li>Indicates the number of samples acquired since a FIFO event flag (overflow or watermark) was asserted.</li> <li>Reset when <b>F_OVF</b> and <b>F_WMKF</b> fall.</li> <li>To clear this field, the F_EVENT flag must be cleared.</li> </ul>   |

## 6.7 0x0B: INT\_SOURCE\_FLAG

The INT\_SOURCE\_FLAG register provides the event-flag status for the interrupt generating functions within the device. Reading the INT\_SRC\_FLAG register does not reset any event-flag source bits; they are reset by reading the appropriate event source register.

**Table 28. INT\_SRC register**

| Bit   | 7 | 6 | 5 | 4 | 3       | 2        | 1      | 0        |
|-------|---|---|---|---|---------|----------|--------|----------|
| Read  | 0 | 0 | 0 | 0 | BOOTEND | SRC_FIFO | SRC_RT | SRC_DRDY |
| Write |   |   |   |   |         |          |        |          |
| Reset | 0 | 0 | 0 | 0 | 0       | 0        | 0      | 0        |

**Table 29. INT\_SRC\_FLAG field descriptions**

| Field        | Description  |
|--------------|--|
| 3<br>BOOTEND | Boot sequence complete event flag <ul style="list-style-type: none"> <li>Asserted as soon as the device boot sequence has completed and remains at '1' thereafter.</li> </ul> 1: Boot sequence is complete<br>0: When one of the following occurs: <ul style="list-style-type: none"> <li>A hard or soft reset event is triggered</li> <li>A POR event occurs</li> </ul> |

*Table continues on the next page...*

**Table 29. INT\_SRC\_FLAG field descriptions (continued)**

| Field         | Description   |
|---------------|---|
| 2<br>SRC_FIFO | <p>FIFO event source flag</p> <ul style="list-style-type: none"> <li>Indicates that the FIFO event flags triggered the interrupt</li> </ul> <p>1: When the FIFO event flag <b>F_Event</b>[F_Event] is set (F_OVF or F_WMKF are set), provided the FIFO interrupt is enabled (<b>CTRL_REG2</b>[INT_EN_FIFO] = 1).</p> <p>0: Cleared when F_Event flag gets cleared (whenever both F_OVF and F_WMKF get cleared).</p> |
| 1<br>SRC_RT   | <p>Rate threshold event source flag</p> <ul style="list-style-type: none"> <li>Indicates that the rate threshold event flag(s) triggered the interrupt</li> </ul> <p>1: When the event active flag <b>RT_SRC</b>[EA] is set, provided the Rate Threshold interrupt is enabled (<b>CTRL_REG2</b>[INT_EN_RT] = 1).</p> <p>0: Cleared when the event active flag <b>RT_SRC</b>[EA] is cleared.</p>                     |
| 0<br>SRC_DRDY | <p>Data-ready event source flag</p> <ul style="list-style-type: none"> <li>Indicates that a data-ready event triggers the interrupt</li> </ul> <p>1: When any of the data-ready flags from <b>DR_STATUS</b> are set, provided the Data Ready interrupt is enabled (<b>CTRL_REG2</b>[INT_EN_DRDY] = 1).</p> <p>0: Cleared by reading the MSBs of the X, Y, and Z axes sample data.</p>                               |

## 6.8 0x0C: WHO\_AM\_I

The WHO\_AM\_I register contains the device identifier which is factory programmed to 0xD7.

**Table 30. WHO\_AM\_I**

| Bit   | 7             | 6 | 5 | 4 | 3 | 2 | 1 | 0 |
|-------|---------------|---|---|---|---|---|---|---|
| Read  | WHO_AM_I[7:0] |   |   |   |   |   |   |   |
| Write |               |   |   |   |   |   |   |   |
| Reset | 1             | 1 | 0 | 1 | 0 | 1 | 1 | 1 |

## 6.9 0x0D: CTRL\_REG0

CTRL\_REG0 is used for general control and configuration of the device. The bit fields in CTRL\_REG0 should be changed only in Standby or Ready modes. Accuracy of the output data is not guaranteed if these bits are changed when the device is in Active mode.

**Table 31. CTRL\_REG0**

|       |         |   |      |          |   |        |         |   |
|-------|---------|---|------|----------|---|--------|---------|---|
| Bit   | 7       | 6 | 5    | 4        | 3 | 2      | 1       | 0 |
| Read  | BW[1:0] |   | SPIW | SEL[1:0] |   | HPF_EN | FS[1:0] |   |
| Write | BW[1:0] |   | SPIW | SEL[1:0] |   | HPF_EN | FS[1:0] |   |
| Reset | 0       | 0 | 0    | 0        | 0 | 0      | 0       | 0 |

**Table 32. CTRL\_REG0 field descriptions**

| Field       | Description  |
|-------------|--|
| 7:6<br>BW   | Bandwidth <ul style="list-style-type: none"> <li>Selects the cut-off frequency of the digital low-pass filter, limiting the bandwidth of the digital output data as shown in <a href="#">Table 33</a>.</li> </ul>  |
| 5<br>SPIW   | SPI interface mode selection<br>0: SPI 4-wire mode (default)<br>1: SPI 3-wire mode (MOSI pin is used for SPI input and output signals)   |
| 4:3<br>SEL  | High-pass filter cutoff frequency selection <ul style="list-style-type: none"> <li>Details of the high-pass filter settings are shown in <a href="#">Table 34</a>.</li> </ul>  |
| 2<br>HPF_EN | High-pass filter enable <ul style="list-style-type: none"> <li>The high-pass filter is initialized on operating mode and ODR change.</li> <li>When enabled, the HPF is applied to the angular rate data supplied to the output registers/FIFO and the embedded rate threshold function.</li> </ul> 0: High-pass filter disabled (default)<br>1: High-pass filter enabled |
| 1:0<br>FS   | Full-scale range selection <ul style="list-style-type: none"> <li>See <a href="#">Table 35</a></li> </ul>  |

**Table 33. FXAS21002C LPF cutoff frequency**

| BW   | ODR = 800 Hz | ODR = 400 Hz | ODR = 200 Hz | ODR = 100 Hz | ODR = 50 Hz | ODR = 25 Hz | ODR = 12.5 Hz |
|------|--------------|--------------|--------------|--------------|-------------|-------------|---------------|
| 0b00 | 256          | 128          | 64           | 32           | 16          | 8           | 4             |
| 0b01 | 128          | 64           | 32           | 16           | 8           | 4           | —             |
| 0b1x | 64           | 32           | 16           | 8            | 4           | —           | —             |

**Table 34. High-pass filter cutoff frequency selection**

| SEL1 | SEL0 | Cutoff Frequency in Hz versus ODR |        |        |        |       |       |         |
|------|------|-----------------------------------|--------|--------|--------|-------|-------|---------|
|      |      | 800 Hz                            | 400 Hz | 200 Hz | 100 Hz | 50 Hz | 25 Hz | 12.5 Hz |
| 0    | 0    | 15                                | 7.5    | 3.75   | 1.875  | 0.937 | 0.468 | 0.234   |
| 0    | 1    | 7.7                               | 3.85   | 1.925  | 0.963  | 0.481 | 0.241 | 0.120   |
| 1    | 0    | 3.9                               | 1.95   | 0.975  | 0.488  | 0.244 | 0.122 | 0.061   |
| 1    | 1    | 1.98                              | 0.99   | 0.495  | 0.248  | 0.124 | 0.062 | 0.031   |

**HPF\_EN** enables the high pass filter. Note that high-pass filter is initialized on mode change, ODR change, and assertion of the zero rate register bit. When enabled, the high-pass filtered data is input to both the output data registers/FIFO and the rate threshold function.

**FS[1:0]** selects the full scale range of the device as shown in [Table 35](#).

**Table 35. Selectable Full Scale Ranges**

| FS1 | FS0 | Range (dps) | Nominal Sensitivity (mdps/LSB) |
|-----|-----|-------------|--------------------------------|
| 0   | 0   | ±2000       | 62.5                           |
| 0   | 1   | ±1000       | 31.25                          |
| 1   | 0   | ±500        | 15.625                         |
| 1   | 1   | ±250        | 7.8125                         |

**NOTE**

Setting the **CTRL\_REG3[FS\_DOUBLE]** increases the dynamic range for each **CTRL\_REG0[FS]** selection by a factor of two, from ±250/500/1000/2000°/s to ±500/1000/2000/4000°/s.

## 6.10 0x0E: RT\_CFG

The RT\_CFG register is used to enable the Rate Threshold interrupt generation. The internal state of the Rate Threshold function is reset when a transition from Standby to Active or Ready to Active modes occurs. The contents should only be modified when the device is in Standby mode.

**Table 36. RT\_CFG Register**

| Bit   | 7 | 6 | 5 | 4 | 3   | 2     | 1     | 0     |
|-------|---|---|---|---|-----|-------|-------|-------|
| Read  | 0 | 0 | 0 | 0 | ELE | ZTEFE | YTEFE | XTEFE |
| Write |   |   |   |   |     |       |       |       |
| Reset | 0 | 0 | 0 | 0 | 0   | 0     | 0     | 0     |



**Table 37. RT\_CFG field descriptions**

| Field      | Description   |
|------------|---|
| 3<br>ELE   | Event latch enable <ul style="list-style-type: none"> <li>See <a href="#">Functionality</a> for more details.</li> </ul> 0: Event flag latch disabled<br>1: Event flag latch enabled                          |
| 2<br>ZTEFE | Event flag enable on Z-axis rate <ul style="list-style-type: none"> <li>Enable bits for rate threshold event detection on the Z axis</li> </ul> 0: Z event detection disabled<br>1: Z Event detection enabled |
| 1<br>YTEFE | Event flag enable on Y-axis rate <ul style="list-style-type: none"> <li>Enable bits for rate threshold event detection on the Y axis</li> </ul> 0: Y event detection disabled<br>1: Y Event detection enabled |
| 0<br>XTEFE | Event flag enable on X-axis rate <ul style="list-style-type: none"> <li>Enable bits for rate threshold event detection on the X axis</li> </ul> 0: X event detection disabled<br>1: X Event detection enabled |

## 6.11 0x0F: RT\_SRC

This register indicates the source of the Rate Threshold event. The content of RT\_SRC is reset upon a transition from Standby to Active or from Ready to Active modes.

**Table 38. RT\_SRC Register**

| Bit   | 7 | 6  | 5   | 4        | 3   | 2        | 1   | 0        |
|-------|---|----|-----|----------|-----|----------|-----|----------|
| Read  | 0 | EA | ZRT | Z_RT_POL | YRT | Y_RT_POL | XRT | X_RT_POL |
| Write |   |    |     |          |     |          |     |          |
| Reset | 0 | 0  | 0   | 0        | 0   | 0        | 0   | 0        |

**Table 39. RT\_SRC field descriptions**

| Field         | Description   |
|---------------|---|
| 6<br>EA       | <p>Event active flag</p> <ul style="list-style-type: none"> <li>EA indicates that a rate threshold event has been detected on at least one of the axes (OR condition). This bit is cleared after a read of this register only if it has been latched (ELE =1).</li> </ul> <p>0: No event flags have been asserted<br/>1: One or more event flags have been asserted (XRT, YRT or ZRT)</p>   |
| 5<br>ZRT      | <p>Z rate event</p> <ul style="list-style-type: none"> <li>Indicates that a rate threshold event (as defined in <a href="#">Functionality</a>) has been detected on the Z-axis (only if RT_CFG[ZTEFE] is 1).</li> <li>Flag is asserted a few samples (RT_COUNT) after the absolute value of the Z output rate data goes above the RT_THS value.</li> <li>Cleared a few samples (RT_COUNT) after the absolute value of Z rate output goes below the RT_THS value. Also cleared when the register is read, if it has been latched (ELE = 1).</li> </ul> <p>0: No rate threshold event detected on Z axis<br/>1: Rate Threshold event detected on Z axis</p> |
| 4<br>Z_RT_POL | <p>Polarity of Z event</p> <ul style="list-style-type: none"> <li>Indicates the rate polarity on the Z-axis (if RT_CFG[ZTEFE] =1). If RT_CFG[ZTEFE] =1, this bit indicates the polarity of the Z data irrespective of the rate threshold event detected on Z-axis.</li> <li>Cleared when read if it has been latched (ELE =1)</li> </ul> <p>0: Z rate event was Positive<br/>1: Z rate event was Negative</p>   |
| 3<br>YRT      | <p>Y rate event</p> <ul style="list-style-type: none"> <li>Indicates that a rate threshold event (as defined in <a href="#">Functionality</a>) has been detected on the Y-axis (only if RT_CFG[YTEFE] =1).</li> <li>Flag is asserted few samples(RT_COUNT) after the absolute value of the Y output rate data goes above the RT_THS value.</li> <li>Cleared a few samples (RT_COUNT) after the absolute value of Y rate output goes below the RT_THS value. Also cleared when the register is read if it has been latched (ELE = 1).</li> </ul> <p>0: No Rate Threshold event detected on Y axis<br/>1: Rate Threshold event detected on Y axis</p>       |
| 2<br>Y_RT_POL | <p>Polarity of Y event</p> <ul style="list-style-type: none"> <li>Indicates the rate polarity on the Y-axis (if RT_CFG[YTEFE] =1). If RT_CFG[YTEFE] =1, this bit indicates the polarity of the Y data irrespective of the rate threshold event detected on Y-axis.</li> <li>Cleared when read if it has been latched (ELE =1)</li> </ul> <p>0: Y rate event was Positive<br/>1: Y rate event was Negative</p>   |

*Table continues on the next page...*

**Table 39. RT\_SRC field descriptions (continued)**

| Field         | Description  |
|---------------|--|
| 1<br>XRT      | X rate Event <ul style="list-style-type: none"> <li>Indicates that a rate threshold event (as defined in <a href="#">Functionality</a>) has been detected on the X-axis (only if RT_CFG[XTEFE] =1).</li> <li>Flag is asserted few samples (RT_COUNT) after the absolute value of the X output rate data goes above the RT_THS value.</li> <li>Cleared a few samples (RT_COUNT) after the absolute value of X rate output goes below the RT_THS value. Also cleared when the register is read if it has been latched (ELE = 1).</li> </ul> 0: No Rate Threshold event detected on X axis<br>1: Rate Threshold event detected on X axis. |
| 0<br>X_RT_POL | Polarity of X event <ul style="list-style-type: none"> <li>Indicates the rate polarity on the X axis (if RT_CFG[XTEFE] =1). If RT_CFG[XTEFE] =1, this bit indicates the polarity of the X-data irrespective of the rate threshold event detected on X-axis.</li> <li>Cleared when read if it has been latched (ELE =1)</li> </ul> 0: X rate event was positive<br>1: X rate event was negative   |

## 6.12 0x10: RT\_THS

The RT\_THS register sets the threshold limit for the detection of the rate and the debounce counter mode. See [Functionality](#) for more details.

**Table 40. RT\_THS register**

| Bit   | 7      | 6        | 5 | 4 | 3 | 2 | 1 | 0 |
|-------|--------|----------|---|---|---|---|---|---|
| Read  | DBCNTM | THS[6:0] |   |   |   |   |   |   |
| Write |        |          |   |   |   |   |   |   |
| Reset | 0      | 0        | 0 | 0 | 0 | 0 | 0 | 0 |

**Table 41. RT\_THS field descriptions**

| Field       | Description   |
|-------------|---|
| 7<br>DBCNTM | Debounce counter mode selection <ul style="list-style-type: none"> <li>The contents should only be modified when the device is in Standby mode</li> </ul> 1: Clear counter when angular rate is below the threshold value<br>0: Decrement counter on every ODR cycle that the angular rate is below the threshold value |

*Table continues on the next page...*

**Table 41. RT\_THS field descriptions (continued)**

| Field      | Description  |
|------------|--|
| 6:0<br>THS | Unsigned 7-bit rate threshold value <ul style="list-style-type: none"> <li>The contents should only be modified when the device is in Standby mode</li> <li>The internal state of the Rate Threshold function is reset when a transition from Standby to Active or Ready to Active modes occurs.</li> <li>The rate threshold in dps is given by the following formula:<br/> <math display="block">\text{Rate Threshold (dps)} = (\text{THS}+1) * 256 * \text{Sensitivity (dps/LSB)}</math> <math display="block">\text{Rate Threshold (LSB)} = (\text{THS}+1) * 256</math> </li> </ul> |

**NOTE**

The sensitivity (dps/LSB) varies with the FSR setting: **CTRL\_REG0[FS]** and also with the FS\_DOUBLE setting: **CTRL\_REG3[FS\_DOUBLE]**. See [Table 54](#) for more sensitivity details on enabling FS\_DOUBLE.

**6.13 0x11: RT\_COUNT**

RT\_COUNT sets the number of debounce counts. See [Functionality](#) for more details.

**Table 42. RT\_COUNT register**

| Bit   | 7           | 6 | 5 | 4 | 3 | 2 | 1 | 0 |
|-------|-------------|---|---|---|---|---|---|---|
| Read  | RT_CNT[7:0] |   |   |   |   |   |   |   |
| Write |             |   |   |   |   |   |   |   |
| Reset | 0           | 0 | 0 | 0 | 0 | 0 | 0 | 1 |

**Table 43. RT\_COUNT field descriptions**

| Field         | Description   |
|---------------|---|
| 7:0<br>RT_CNT | Debounce counter value <ul style="list-style-type: none"> <li>The contents should only be modified when the device is in Standby mode</li> <li>The internal state of the Rate Threshold function debounce counter is reset when a transition from Standby to Active or Ready to Active modes occurs</li> <li>Stores the number of counts with the angular rate above the threshold needed before asserting the rate threshold event flag</li> <li>The counter period is the same as the selected ODR period, allowing for a debounce time to be calculated. For example, an RT_COUNT value of 10 (decimal) and an ODR of 100 Hz would result in a debounce time of 100 ms.</li> </ul> |

## 6.14 0x12: TEMP

The TEMP register contains an 8-bit 2's complement temperature value with a range of  $-128\text{ }^{\circ}\text{C}$  to  $+127\text{ }^{\circ}\text{C}$  and a scaling of  $1\text{ }^{\circ}\text{C}/\text{LSB}$ . The temperature data is only compensated (factory trim values applied) when the device is operating in the Active mode and actively measuring the angular rate.

**Table 44. TEMP register**

| Bit   | 7         | 6 | 5 | 4 | 3 | 2 | 1 | 0 |
|-------|-----------|---|---|---|---|---|---|---|
| Read  | TEMP[7:0] |   |   |   |   |   |   |   |
| Write |           |   |   |   |   |   |   |   |
| Reset | 0         | 0 | 0 | 0 | 0 | 0 | 0 | 0 |

## 6.15 0x13: CTRL\_REG1

The CTRL\_REG1 register is used to configure the device ODR, set the operating mode, soft-reset the device, and exercise the Self-Test function.

### NOTE

Control bits in CTRL\_REG1 should be changed only in Standby or Ready mode. Accuracy of the output data is not guaranteed if these bits are changed while the device is in Active mode.

**Table 45. CTRL\_REG1 register**

| Bit   | 7 | 6   | 5  | 4       | 3 | 2 | 1      | 0     |
|-------|---|-----|----|---------|---|---|--------|-------|
| Read  | — | RST | ST | DR[2:0] |   |   | ACTIVE | READY |
| Write |   |     |    |         |   |   |        |       |
| Reset | 0 | 0   | 0  | 0       | 0 | 0 | 0      | 0     |

**Table 46. CTRL\_REG1 field descriptions**

| Field    | Description   |
|----------|---|
| 6<br>RST | Software Reset: <ul style="list-style-type: none"> <li>Used to trigger a reset of the device.</li> <li>On reset, all registers except 0x01 through 0x06 revert to their default values. Register addresses 0x01 through 0x06 contain values that cannot be determined.</li> <li>This bit is self cleared after assertion.</li> </ul> 0: Device reset not triggered/completed<br>1: Device reset triggered |

*Table continues on the next page...*

**Table 46. CTRL\_REG1 field descriptions (continued)**

| Field       | Description   |
|-------------|---|
| 5<br>ST     | Self-Test enable <ul style="list-style-type: none"> <li>When ST is set, a data output change will occur even if no angular rate is applied. This allows the host application to check the functionality of the sensor and the entire measurement signal chain. The expected Self-Test delta value is summarized in <a href="#">Table 4</a></li> </ul> 0: Self-Test disabled<br>1: Self-Test enabled |
| 4:2<br>DR   | Output Data Rate selection <ul style="list-style-type: none"> <li>Selects the output data rate as per <a href="#">Table 47</a></li> </ul>   |
| 1<br>Active | Standby/Active mode selection, see <a href="#">Table 48</a>   |
| 0<br>Ready  | Standby/Ready mode selection, see <a href="#">Table 48</a>  |

**NOTE**

On issuing a Software Reset command over an I<sup>2</sup>C interface, the device immediately resets and does not send any acknowledgment (ACK) of the written byte to the Master.

**Table 47. Digital output data bandwidth settings**

| Decimal number | CTRL_REG1[DR] | ODR (Hz) |
|----------------|---------------|----------|
| 0              | 000           | 800      |
| 1              | 001           | 400      |
| 2              | 010           | 200      |
| 3              | 011           | 100      |
| 4              | 100           | 50       |
| 5              | 101           | 25       |
| 6              | 110           | 12.5     |
| 7              | 111           | 12.5     |

The **ACTIVE** and **READY** bits are used to control the device operating mode. In Standby mode (**ACTIVE** = 0), the device is only capable of communication on the I<sup>2</sup>C or SPI digital interfaces. In Ready mode (**READY** = 1), the device is ready to measure angular rate but no data acquisitions are being made. The Ready mode can be used to reduce the device power consumption and allow for a fast transition into the Active mode when needed. In Active mode (**ACTIVE** = 1), the device is fully functional. The **ACTIVE** bit has a higher priority than the **READY** bit as shown in [Table 48](#).

**Table 48. Device operating mode**

| Active | Ready | Operating mode |
|--------|-------|----------------|
| 0      | 0     | Standby        |
| 0      | 1     | Ready          |
| 1      | X     | Active         |

When **CTRL\_REG3[EXTCTRLLEN]** = 1, the **ACTIVE** bit is directly controlled by the logic level input to the INT2/PWR\_CTRL pin and becomes read-only via the register interface. Thus, the device operating mode can be directly controlled by the INT2/PWR\_CTRL pin when **CTRL\_REG3[EXTCTRLLEN]** = 1. The weak pull-up resistor is internal to the IC and automatically enabled when **CTRL\_REG3[EXTCTRLLEN]** is set to 1, hence setting the Active bit high.

## 6.16 0x14: CTRL\_REG2

This register enables and assigns the output pin(s) and logic polarities for the various interrupt sources available on the device.

**Table 49. CTRL\_REG2 register**

| Bit   | 7            | 6           | 5          | 4         | 3            | 2           | 1        | 0         |
|-------|--------------|-------------|------------|-----------|--------------|-------------|----------|-----------|
| Read  | INT_CFG_FIFO | INT_EN_FIFO | INT_CFG_RT | INT_EN_RT | INT_CFG_DRDY | INT_EN_DRDY | IPO<br>L | PP_O<br>D |
| Write |              |             |            |           |              |             |          |           |
| Reset | 0            | 0           | 0          | 0         | 0            | 0           | 0        | 0         |

**Table 50. Interrupt Enable register descriptions**

| Register          | Description  |
|-------------------|--|
| 7<br>INT_CFG_FIFO | FIFO interrupt pin routing<br>0: Interrupt is routed to INT2 pin<br>1: Interrupt is routed to INT1 pin |
| 6<br>INT_EN_FIFO  | FIFO Interrupt Enable<br>0: FIFO interrupt disabled<br>1: FIFO interrupt enabled                       |

*Table continues on the next page...*

**Table 50. Interrupt Enable register descriptions (continued)**

| Register          | Description   |
|-------------------|---|
| 5<br>INT_CFG_RT   | Rate threshold interrupt pin routing<br>0: Interrupt is routed to INT2 pin<br>1: Interrupt is routed to INT1 pin                              |
| 4<br>INT_EN_RT    | Rate threshold interrupt enable<br>0: Rate threshold interrupt disabled<br>1: Rate threshold interrupt enabled                                |
| 3<br>INT_CFG_DRDY | Data-ready interrupt pin routing<br>0: Interrupt is routed to INT2 pin<br>1: Interrupt is routed to INT1 pin                                  |
| 2<br>INT_EN_DRDY  | Data ready interrupt enable<br>0: Data-ready interrupt disabled<br>1: Data-ready interrupt enabled  |
| 1<br>IPOL         | Interrupt logic polarity<br>0: Active low<br>1: Active high   |
| 0<br>PP_OD        | INT1 and INT2 pin output driver configuration<br>0: Push-pull output driver<br>1: Open-drain/open-source buffer with IPOL = 0/1, respectively |

**Table 51. INT pin behavior as a function of PP\_OD and IPOL bit settings**

| INT pin configuration             | PP_OD | IPOL | INT asserted value | INT deasserted value |
|-----------------------------------|-------|------|--------------------|----------------------|
| CMOS output                       | 0     | 0    | 0                  | 1                    |
| CMOS output                       | 0     | 1    | 1                  | 0                    |
| External pull-up resistor added   | 1     | 0    | 0                  | High-z <sup>1</sup>  |
| External pull-down resistor added | 1     | 1    | 1                  | High-z <sup>1</sup>  |

1. High-z = tri-state (high impedance) condition; the state of the INT pin will be defined by the external pull-up or pull-down resistor.

## 6.17 0x15:CTRL\_REG3

This register is used to enable the FSR expansion, external power control input, and options to modify the auto-increment read address pointer behavior when doing burst reads of the FIFO data.



**Table 52. CTRL\_REG3 register**

| Bit   | 7 | 6 | 5 | 4 | 3         | 2          | 1 | 0         |
|-------|---|---|---|---|-----------|------------|---|-----------|
| Read  | — | — | — | — | WRAPTOONE | EXTCTRLLEN | — | FS_DOUBLE |
| Write | — | — | — | — |           |            |   |           |
| Reset | — | — | — | — | 0         | 0          | — | 0         |

### NOTE

Control bits in CTRL\_REG3 should only be changed when operating in Standby or Ready mode. Accuracy of the output data is not guaranteed if any of these bits are changed while the device is operating in Active mode.

**Table 53. CTRL\_REG3 register descriptions**

| Register        | Description  |
|-----------------|--|
| 3<br>WRAPTOONE  | Auto-increment read address pointer roll-over behavior:<br>0: The auto-increment read address pointer rolls over to address 0x00 (STATUS) after the Z-axis LSB is read (default).<br>1: The auto-increment pointer rolls over to address 0x01 (X-axis MSB) in order to facilitate the faster read out of the FIFO data in a single burst read operation (STATUS register only needs to be read once).  |
| 2<br>EXTCTRLLEN | External power mode control input:<br>0: INT2 pin is used as an interrupt output (default)<br>1: INT2 pin becomes an input pin that may be used to control the power mode. Note that when EXTCTRLLEN is set, the interrupt outputs and related settings for the INT2 pin are ignored.<br>EXTCTRLLEN allows the device operating mode to be controlled using the INT2 pin (the pin becomes a high impedance input when this bit is set high). The input is level sensitive, and allows the host to transition the device operating mode from either Standby to Active or from Ready to Active (and vice-versa) depending on the operating mode, Standby or Ready, that was configured at the time this bit was set.               |
| 0<br>FS_DOUBLE  | Full-scale range expansion enable:<br>0: Maximum full-scale range selections are as per <a href="#">Table 37</a> , selected via the <b>CTRL_REG0[FS]</b> field.<br>1: Maximum full-scale range selections are doubled from what is shown in <a href="#">Table 37</a> .<br>FS_DOUBLE increases the dynamic range for each <b>CTRL_REG0[FS]</b> selection by a factor of two, from $\pm 250/500/1000/2000^\circ/s$ to $\pm 500/1000/2000/4000^\circ/s$ . This feature is provided to enable a higher dynamic range for applications such as sports equipment monitoring (e.g. golf club or tennis racket swings). While the full-scale range is doubled in this mode, the noise and nonlinearity of the signal are also increased. |

**Table 54. Rate sensitivity changes with FSR\_DOUBLE setting**

| FSR Selection      | Sensitivity (mdps/LSB) |                |
|--------------------|------------------------|----------------|
|                    | FSR_DOUBLE = 0         | FSR_DOUBLE = 1 |
| CTRL_REG0[FS] = 00 | 62.50                  | 125.0          |
| CTRL_REG0[FS] = 01 | 31.25                  | 62.50          |
| CTRL_REG0[FS] = 10 | 15.625                 | 31.25          |
| CTRL_REG0[FS] = 11 | 7.8125                 | 15.625         |

## 7 Printed Circuit Board Layout and Device Mounting

Printed Circuit Board (PCB) layout and device mounting are critical to the overall performance of the design. The footprint for the surface mount packages must be the correct size as a base for a proper solder connection between the PCB and the package. This, along with the recommended soldering materials and techniques, will optimize assembly and minimize the stress on the package after board mounting.

Freescale application note [AN1902, "Assembly Guidelines for QFN and DFN Packages"](#) discusses the QFN package used by the FXAS21002C.

### 7.1 Printed Circuit Board Layout

The following recommendations are meant to serve as general guidelines for realizing an effective PCB layout. See [Figure 24](#) for component PCB footprint dimensions.

- The PCB land pattern should be designed with Non-Solder Mask Defined (NSMD) as shown in [Figure 24](#).
- On the layer that the device is soldered, there should be no trace routing or vias underneath the device's component package.
- No components or vias should be placed at a distance less than 2 mm from the package land area. This may cause additional package stress if it is too close to the package land area.
- Signal traces connected to pads should be as symmetric as possible. Put dummy traces on the NC pads in order to have same length of exposed trace for all pads.
- No copper traces should be on the top layer of the PCB under the package, as this will cause planarity issues with the board mount. Freescale QFN sensors are compliant with Restrictions on Hazardous Substances (RoHS), having halide-free molding compound (green) and lead-free terminations. These terminations are

compatible with tin-lead (Sn-Pb) as well as tin-silver-copper (Sn-Ag-Cu) solder paste soldering processes. Reflow profiles applicable to those processes can be used successfully for soldering the devices.

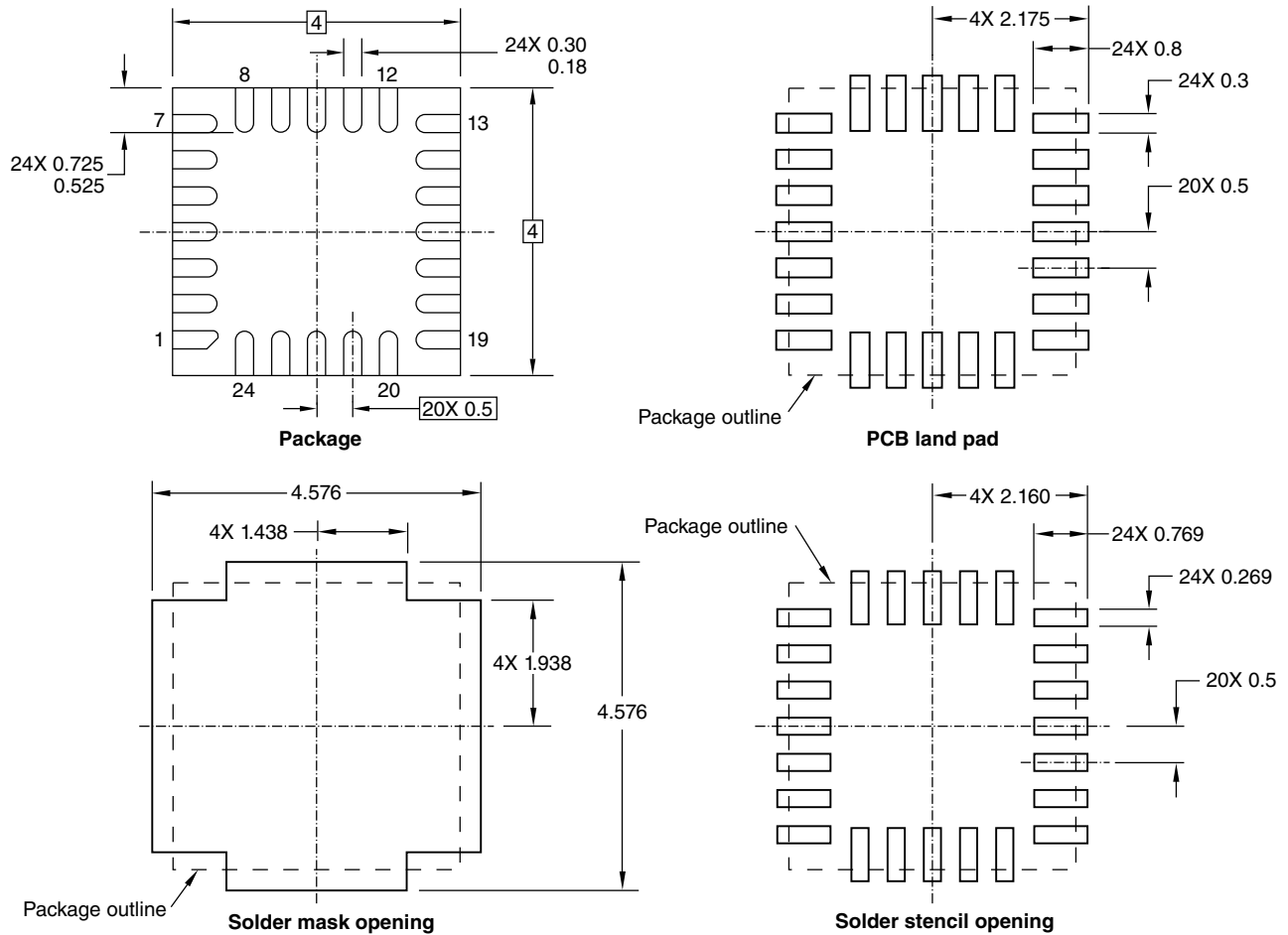


Figure 24. Footprint

## 7.2 Overview of Soldering Considerations

The information provided here is based on experiments executed on QFN devices. These experiments cannot represent exact conditions present at a customer site. Therefore, information herein should be used for guidance purposes only. Process and design optimizations are recommended to develop an application-specific solution. With the proper PCB footprint and solder stencil designs, the package will self-align during the solder reflow process.

- Stencil thickness should be 100 or 125  $\mu\text{m}$ .

## Package Information

- The PCB should be rated for the multiple lead-free reflow condition with a maximum 260 °C temperature.
- Use a standard pick-and-place process and equipment. Do not use a hand soldering process.
- Do not use a screw-down or stacking to mount the PCB into an enclosure. These methods could bend the PCB, which would put stress on the package.

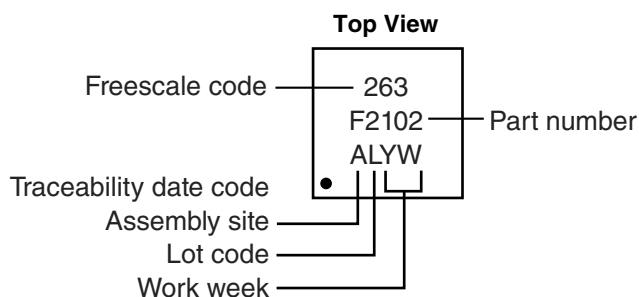
## 7.3 Halogen Content

This package is designed to be Halogen Free, exceeding most industry and customer standards. Halogen Free means that no homogeneous material within the assembled package will contain chlorine (Cl) in excess of 700 ppm or 0.07% weight/weight or bromine (Br) in excess of 900 ppm or 0.09% weight/weight.

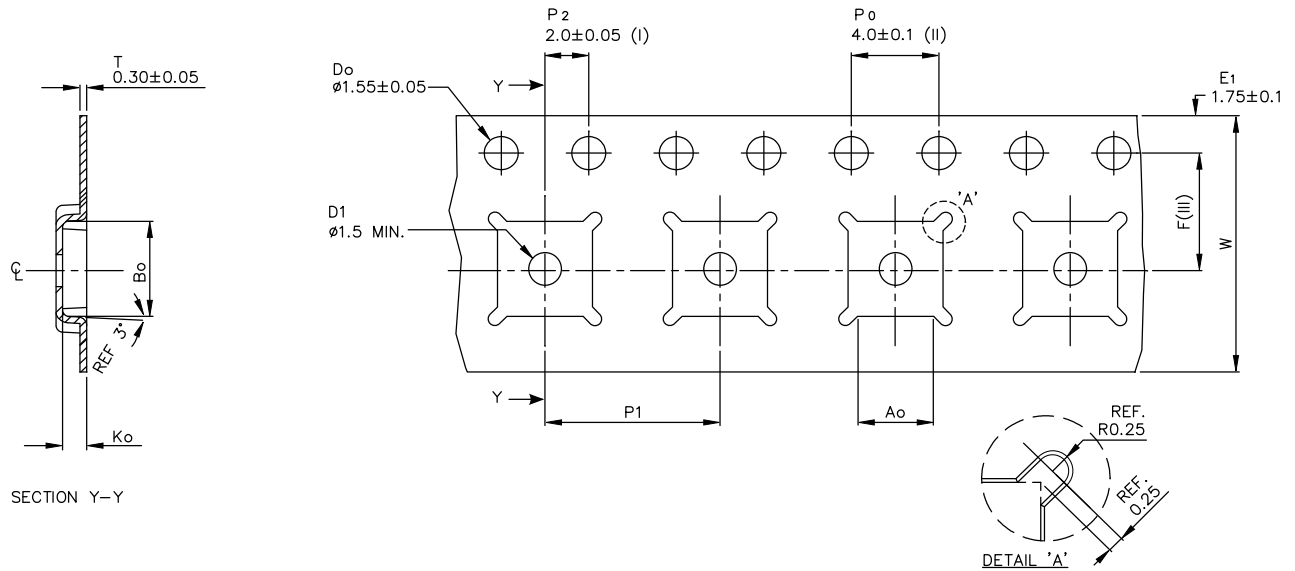
## 8 Package Information

The FXAS21002C platform uses a 24-lead QFN package, case number 2209-01.

### 8.1 Product Identification Markings



## 8.2 Tape and Reel Information



|    |               |
|----|---------------|
| Ao | 4.35 +/- 0.1  |
| Bo | 4.35 +/- 0.1  |
| Ko | 1.10 +/- 0.1  |
| F  | 5.50 +/- 0.05 |
| P1 | 8.00 +/- 0.1  |
| W  | 12.00 +/- 0.3 |

- (I) Measured from centerline of sprocket hole to centerline of pocket.
  - (II) Cumulative tolerance of 10 sprocket holes is  $\pm 0.20$ .
  - (III) Measured from centerline of sprocket hole to centerline of pocket.
  - (IV) Other material available.
  - (V) Typical SR value Max  $10^9$  OHM/SQ
- ALL DIMENSIONS IN MILLIMETERS UNLESS OTHERWISE STATED.

Figure 25. Tape dimensions

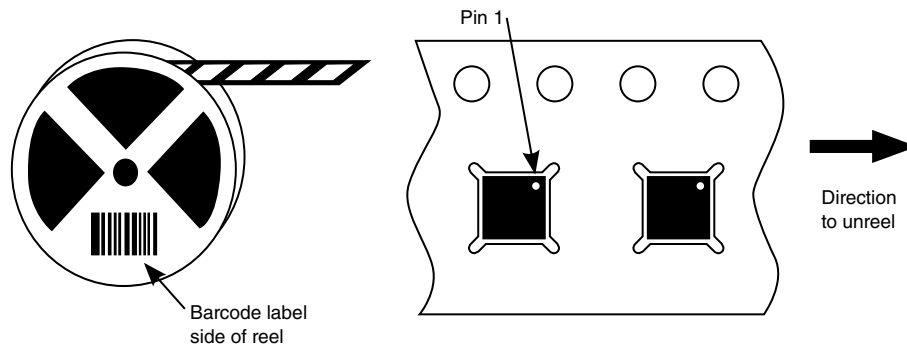
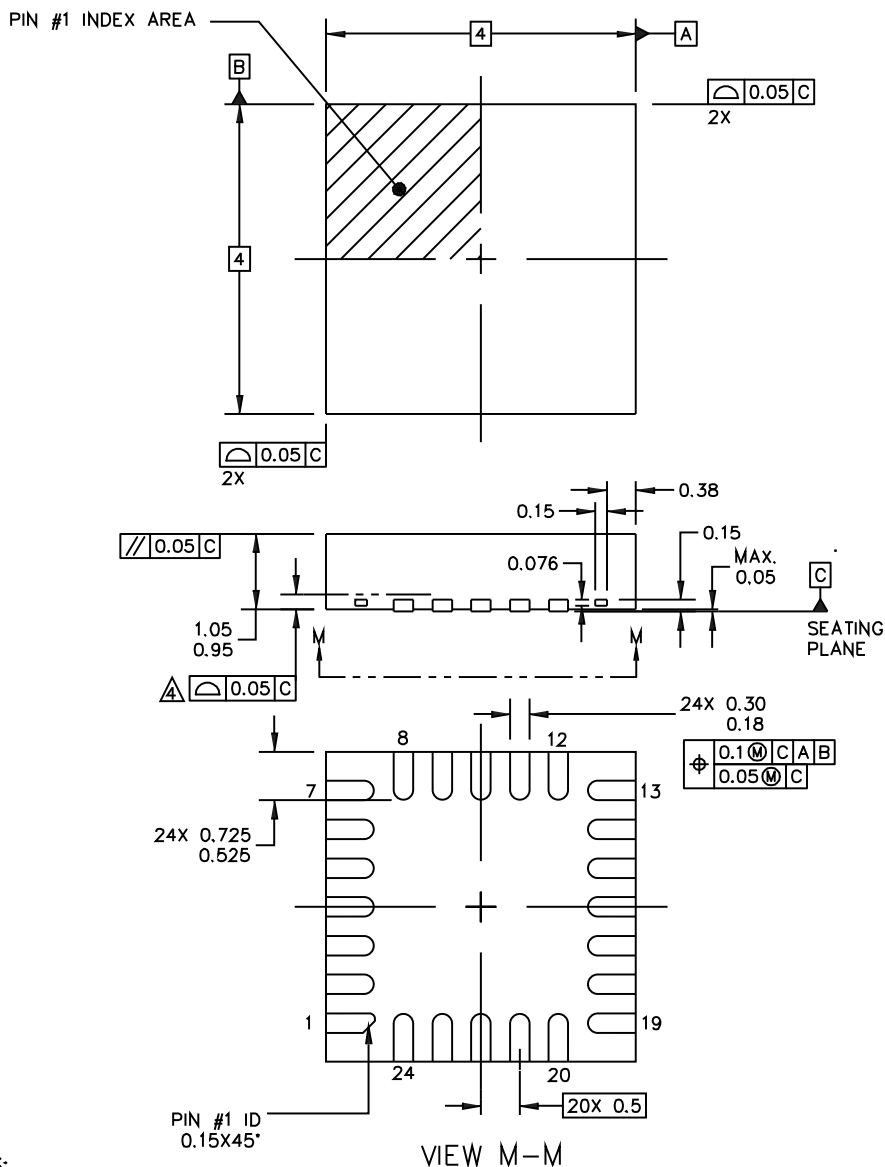


Figure 26. Tape and reel orientation

### 8.3 Package Description



**NOTES:**

1. ALL DIMENSIONS ARE IN MILLIMETERS.
2. DIMENSIONING AND TOLERANCING PER ASME Y14.5M-1994.
3. THIS IS A NON-JEDEC REGISTERED PACKAGE.
4. COPLANARITY APPLIES TO LEADS AND DIE ATTACH FLAG.
5. MIN. METAL GAP SHOULD BE 0.2 MM.

|  |                          |                            |  |
|--|--------------------------|----------------------------|--|
| © FREESCALE SEMICONDUCTOR, INC.<br>ALL RIGHTS RESERVED.                    | MECHANICAL OUTLINE       | PRINT VERSION NOT TO SCALE |  |
| TITLE:<br>QFN,<br>CHIP ON LEAD (COL),<br>4 X 4 X 1, 0.5 PITCH, 24 TERMINAL | DOCUMENT NO: 98ASA00356D | REV: 0                     |  |
|  | CASE NUMBER: 2209-01     | 15 DEC 2011                |  |
|  | STANDARD: NON-JEDEC      |                            |  |

This drawing is located at [www.freescale.com/files/shared/doc/package\\_info/98ASA00356D.pdf](http://www.freescale.com/files/shared/doc/package_info/98ASA00356D.pdf).

## 9 Revision History

| Revision number | Revision date | Description  |
|-----------------|---------------|--|
| 0.3             | 3/2014        | Initial release of document  |
| 1.0             | 8/2014        | <p>Added the following sections:</p> <ul style="list-style-type: none"> <li>• Mechanical and Electrical Specifications</li> <li>• Digital Interfaces</li> <li>• Modes of Operation</li> <li>• Functionality</li> <li>• Register Descriptions</li> <li>• Printed Circuit Board Layout and Device Mounting</li> </ul>  |
| 1.1             | 11/2014       | <ul style="list-style-type: none"> <li>• Figure 1, removed BYP</li> <li>• Table 2, removed T = 25°C from Test conditions</li> <li>• Table 6, removed "Sensitivity error due to linear acceleration removed Zero Rate Offset error due to linear acceleration Added footnote to Zero-rate Offset, Post-Board Mount"</li> <li>• Section 5.2, image, added Latch and ELE connection</li> <li>• Section 6.4, removed "Reading F_STATUS clears the SRC_FIFO bit in the 0x0B: INT_SOURCE_FLAG register."</li> <li>• Table 27, F_EVENT field, added bullet: To clear this flag, both F_OVF and F_WMKF flags must be cleared. See F_STATUS for details.</li> <li>• Table 27, F_EVENT field, added bullet: To clear this field, the F_EVENT flag must be cleared.</li> <li>• Table 29, SRC_FIFO field, changed flag descriptions from <ul style="list-style-type: none"> <li>1: F_OVF or F_WMKF are set, provided the FIFO interrupt is enabled (<b>CTRL_REG2</b>[INT_EN_FIFO=1])</li> <li>0: Cleared by reading the register</li> </ul> to <ul style="list-style-type: none"> <li>1: When F_Event flag is set (F_OVF or F_WMKF are set), provided the FIFO interrupt is enabled (<b>CTRL_REG2</b>[INT_EN_FIFO=1])</li> <li>0: Cleared when F_Event Flag gets cleared (whenever both F_OVF and F_WMKF get cleared)</li> </ul> </li> <li>• Table 29, SRC_RT field, changed bullets from <ul style="list-style-type: none"> <li>• Indicates that the rate threshold event flag triggered the interrupt</li> <li>• Cleared by reading RT_SRC register</li> </ul> to <ul style="list-style-type: none"> <li>• Indicates that the rate threshold event flag(s) triggered the interrupt (when XRT or YRT or ZRT(logical OR) event threshold flags go high)</li> <li>• Cleared when XRT, YRT or ZRT event threshold flags are cleared.</li> </ul> </li> <li>• Section 6.11, added: "It also clears the RT_SRC flag in the 0x0B: INT_SOURCE_FLAG register."</li> <li>• Added Table 54, <i>Rate sensitivity changes with FSR_DOUBLE setting</i></li> </ul> |
| 1.2             | 11/2014       | <ul style="list-style-type: none"> <li>• Removed last two features items</li> <li>• Minor changes to table 2, Temperature Sensor Characteristics</li> <li>• In Mechanical Characteristics table, changed typical parameters for Zero-rate Offset, Zero-rate Offset, Post-board Mount and Integral nonlinearity and updated table footnotes.</li> </ul>   |

*Table continues on the next page...*

## Revision History

| Revision number | Revision date | Description  |
|-----------------|---------------|--|
|                 |               | <ul style="list-style-type: none"> <li>• Updated Electrical Characteristics table, for Supply current drain in Standby mode, and Supply current drain in Standby mode over Temperature parameters. Also removed test condition on Output Data Rate frequency tolerance parameter.</li> <li>• Changed Table 8 Serial interface pin descriptions, pin currently named SDA/MOSI/ SPI_Data and modified pin description.</li> <li>• changed Table 9, Slave timing values, for parameter SDA and SCL fall time, minimum values for I<sup>2</sup>C Fast Mode.</li> <li>• Added table title to Table 10. I<sup>2</sup>C Register Data Address Map.</li> <li>• Section 3.1.1, I<sup>2</sup>C Operation, changed first paragraph to read “External pull-up resistors connected to V<sub>DDIO</sub>”...</li> <li>• Section 5, functionality, changed seventh bullet to read “Embedded rate threshold detection function with programmable debounce time”</li> <li>• Added new column “Auto-Increment Address” to Table 13 Register address map and populated the column with data. Removed last two rows of table, Auto-Increment address and Fast-read increment address.</li> <li>• Modified note after Table 19 to read “After this register is read, the next read register by the autoincrement process is STATUS at 0x00, when CTRL_REG3[WRAPTOONE] = 0, or OUT_X_MSB when CTRL_REG3[WRAPTOONE] = 1.”</li> </ul>   |
| 2.0             | 2/2015        | <ul style="list-style-type: none"> <li>• Moved Section 2.1 to 2.5</li> <li>• Figure 12, changed "SPI_DIO" to "SPI_DATA"</li> <li>• Register 0x09: F_SETUP, added "The contents should only be modified when the device is in Standby mode."</li> <li>• Table 29, Field 1, changed "...XRT, YRT or ZRT..." to "...XRT, YRT and ZRT..."</li> <li>• Register 0x0E: RT_CFG, added "The internal state of the Rate Threshold function is reset when..."</li> <li>• Table 37, Field 3, deleted second and third bullet</li> <li>• Register 0x0F: RT_SRC, added "The content of this register is reset upon a transition from Standby to Active or from Ready to Active modes.</li> <li>• Table 39: <ul style="list-style-type: none"> <li>Field 6 <ul style="list-style-type: none"> <li>• added "only if it has been latched (ELE =1)"</li> <li>• added to bit 1 "(XRT, YRT or ZRT)"</li> </ul> </li> <li>Field 5 <ul style="list-style-type: none"> <li>• changed second bullet to "Flag is asserted few samples (RT_COUNT)..."</li> <li>• added third bullet "Cleared when the absolute value of Z..."</li> <li>• changed bit 0 from "Z rate lower than RT_THS value" to "No rate threshold event detected on Z-axis"</li> <li>• changed bit 1 from "Z rate greater than RT_THS event has occurred" to "Rate Threshold event detected on Z axis"</li> </ul> </li> <li>Field 4 <ul style="list-style-type: none"> <li>• changed first bullet from "Indicates the rate polarity on the Z-axis (if ZTEFE =1). If ZTEFE =1, this bit indicates the polarity of the Z data irrespective of the rate threshold event detected on Z-axis." to "Indicates the rate polarity on the Z-axis (if RT_CFG[ZTEFE] =1). If RT_CFG[ZTEFE] =1, this bit indicates the polarity of the Z data irrespective of the rate threshold event detected on Z-axis."</li> </ul> </li> <li>Field 3 <ul style="list-style-type: none"> <li>• changed second bullet to "Flag is asserted few samples (RT_COUNT)..."</li> <li>• added third bullet "Cleared when the absolute value of Y..."</li> <li>• changed bit 0 from "Y rate lower than RT_THS value" to "No rate threshold event detected on Y-axis"</li> <li>• changed bit 1 from "Y rate greater than RT_THS event has occurred" to "Rate Threshold event detected on Y-axis"</li> </ul> </li> <li>Field 2</li> </ul> </li> </ul> |

*Table continues on the next page...*



| Revision number | Revision date | Description   |
|-----------------|---------------|---|
|                 |               | <ul style="list-style-type: none"> <li>• changed first bullet from "Indicates the rate polarity on the Y-axis (if YTEFE =1). If YTEFE =1, this bit indicates the polarity of the Y data irrespective of the rate threshold event detected on Y-axis." to "Indicates the rate polarity on the Y-axis (if <b>RT_CFG[YTEFE]</b> =1). If <b>RT_CFG[YTEFE]</b> =1, this bit indicates the polarity of the Y data irrespective of the rate threshold event detected on Y-axis."</li> </ul> <p>Field 1</p> <ul style="list-style-type: none"> <li>• changed second bullet to "Flag is asserted few samples (RT_COUNT)..."</li> <li>• added third bullet "Cleared when the absolute value of X..."</li> <li>• changed bit 0 from "X rate lower than RT_THS value" to "No rate threshold event detected on X-axis"</li> <li>• changed bit 1 from "X rate greater than RT_THS event has occurred" to "Rate Threshold event detected on X-axis"</li> </ul> <p>Field 0</p> <ul style="list-style-type: none"> <li>• changed first bullet from "Indicates the rate polarity on the X-axis (if XTEFE =1). If XTEFE =1, this bit indicates the polarity of the X data irrespective of the rate threshold event detected on X-axis." to "Indicates the rate polarity on the X-axis (if <b>RT_CFG[XTEFE]</b> =1). If <b>RT_CFG[XTEFE]</b> =1, this bit indicates the polarity of the X data irrespective of the rate threshold event detected on X-axis."</li> <li>• Table 41, Field 6:0, changed formula from "Rate_threshold=THS*(Full_scale/128)" to "Rate Threshold (in dps) = (THS + 1)* 256 * Sensitivity (in dps/LSB)" and "Rate_Threshold(in LSB) = (THS + 1)* 256"</li> </ul> |
| 2.1             | 5/2015        | <ul style="list-style-type: none"> <li>• Table 5, Self-test output change, Min value of 7000 added and Max value of 25000 added</li> <li>• Table 6 <ul style="list-style-type: none"> <li>• Digital high level input voltage, added SCLK</li> <li>• Low-level output voltage, added test condition of <math>I_o = 1 \text{ mA}</math></li> </ul> </li> <li>• Section 5, second bullet, changed <b>CTRL_REG3[FSR_DOUBLE]</b> = 1 to <b>CTRL_REG3[FS_DOUBLE]</b> = 1</li> <li>• Table 13 <ul style="list-style-type: none"> <li>• F_EVENT, added the default value of 0x00</li> <li>• INT_SRC_FLAG, added the default value of 0x00</li> <li>• CTRL_REG3, changed Auto-increment address from 0x16 to 0x00</li> <li>• RESERVED, added Auto-increment address of address + 1</li> </ul> </li> </ul>  |

**How to Reach Us:**

**Home Page:**

[freescale.com](http://freescale.com)

**Web Support:**

[freescale.com/support](http://freescale.com/support)

Information in this document is provided solely to enable system and software implementers to use Freescale products. There are no express or implied copyright licenses granted hereunder to design or fabricate any integrated circuits based on the information in this document. Freescale reserves the right to make changes without further notice to any products herein.

Freescale makes no warranty, representation, or guarantee regarding the suitability of its products for any particular purpose, nor does Freescale assume any liability arising out of the application or use of any product or circuit, and specifically disclaims any and all liability, including without limitation consequential or incidental damages. "Typical" parameters that may be provided in Freescale data sheets and/or specifications can and do vary in different applications, and actual performance may vary over time. All operating parameters, including "typicals," must be validated for each customer application by customer's technical experts. Freescale does not convey any license under its patent rights nor the rights of others. Freescale sells products pursuant to standard terms and conditions of sale, which can be found at the following address: [freescale.com/SalesTermsandConditions](http://freescale.com/SalesTermsandConditions).

Freescale, and the Freescale logo, are trademarks of Freescale Semiconductor, Inc., Reg. U.S. Pat. & Tm. Off. The Energy Efficient Solutions logo is a trademark of Freescale Semiconductor, Inc. All other product or service names are the property of their respective owners.

© 2014-2015 Freescale Semiconductor, Inc.

# Mouser Electronics

Authorized Distributor

Click to View Pricing, Inventory, Delivery & Lifecycle Information:

[NXP:](#)

[FXAS21002CQR1](#)