



# I<sup>2</sup>C-bus Components Selection Guide

## TABLE OF CONTENTS

|   |    |
|---|----|
| Overview . . . . .  | 1  |
| I <sup>2</sup> C-bus System Diagram . . . . .   | 2  |
| General Purpose Input<br>Output (GPIO) Expanders . . . . .  | 3  |
| Thermal Sensors and<br>Voltage Management . . . . .   | 6  |
| LCD Display Drivers . . . . .   | 8  |
| Clocks and<br>Real Time Clocks . . . . .  | 11 |
| Tiny Serial Analog-to-Digital<br>and Digital-to-Analog<br>Converters . . . . .                            | 12 |
| Multiplexers and Switches . . . . .   | 13 |
| Bus Buffers and<br>Voltage Translators . . . . .  | 15 |
| I <sup>2</sup> C-Controlled EEPROM,<br>RAM and DIP Switches<br>(multiplexed/latched<br>EEPROMS) . . . . . | 18 |
| Intelligent Stepper<br>Motor Controller . . . . .   | 20 |
| Bridge Integrated Circuits<br>and Bus Controllers . . . . .   | 21 |
| Blinkers, Dimmers, Drivers<br>(LED Controllers) . . . . .   | 23 |
| Capacitive Sensors . . . . .  | 25 |
| Demo Boards . . . . .   | 27 |
| Resources . . . . .   | 28 |
| Contact Information . . . . .   | 29 |

## Overview

By replacing complex parallel interfaces with a straightforward yet powerful serial structure, the Inter-Integrated Circuit (I<sup>2</sup>C) bus revolutionized chip-to-chip communications. The I<sup>2</sup>C-bus shrinks integrated circuit (IC) footprints by reducing connection count, leading to lower IC costs, which in turn simplifies printed circuit board (PCB) design complexity and reduces system cost. This bus components selection guide provides an overview of NXP's deep I<sup>2</sup>C-bus solutions portfolio.

### History

As electronic designs grew in complexity, a need developed for an easy and more cost effective way to connect peripheral devices to their controlling microprocessors. To meet this need, Philips Semiconductors (now NXP Semiconductors) invented a simple bidirectional 2-wire bus. Originally created over thirty years ago for television applications, the I<sup>2</sup>C-bus has since become a de facto industry standard supported by many companies.

### I<sup>2</sup>C Features

The I<sup>2</sup>C-bus requires only two lines: a serial data line (SDA) and a serial clock line (SCL). Each device connected to the bus is software addressable by a unique address, and simple master/slave relationships exist at all times.

### Operation

Serial 8-bit bidirectional data transfers occur at up to 100kbit/s in the Standard mode, up to 400kbit/s in Fast-mode (Fm), up to 1Mbit/sec in Fast-mode plus (Fm+), up to 3.4 Mbit/s in high-speed mode (Hs), and up to 5 Mbits/s (unidirectional) in the new Ultra-Fast-mode (UFm).

### I<sup>2</sup>C Applications

Although originally designed to link a small number of devices locally, improvements to bus speed options and the introduction of bus extension devices has allowed the use of the I<sup>2</sup>C-bus to grow from applications such as cell phones and car radios to systems spanning rooms and even buildings.

### I<sup>2</sup>C Specification

For the I<sup>2</sup>C-bus specification and user manual, please visit:  
[http://www.nxp.com/documents/user\\_manual/UM10204.pdf](http://www.nxp.com/documents/user_manual/UM10204.pdf)

## I<sup>2</sup>C-bus System Diagram

NXP divides the I<sup>2</sup>C peripherals portfolio into twelve families, one for each of the most common, everyday design concerns.

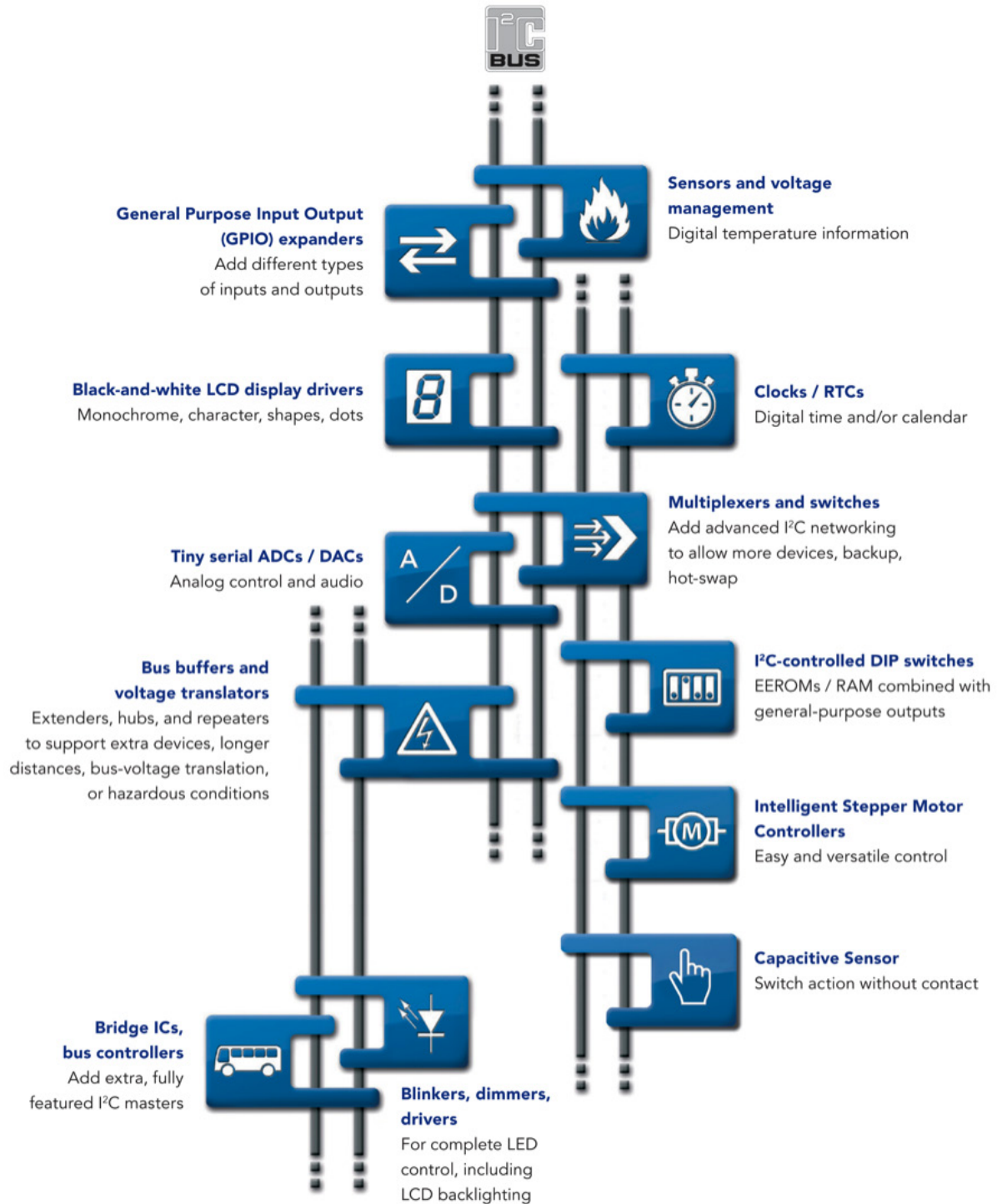

## General Purpose Input Output (GPIO) Expanders

As applications demand more control and monitoring features, the General Purpose I/O (GPIO) ports on microprocessors become more valuable. GPIO expanders provide expansion capability for most microprocessor families, allowing designers to save the microprocessor GPIO for other important functions.

### Features

All of NXP's I<sup>2</sup>C GPIO expanders offer similar functionality, and most have an /INT output, but several also have a /RESET input or /RESET and /OE input.

### Applications

- LED control
- Hardware control monitors
- Humidity sensors
- System monitoring
- ACPI power switches
- Push buttons
- Fans

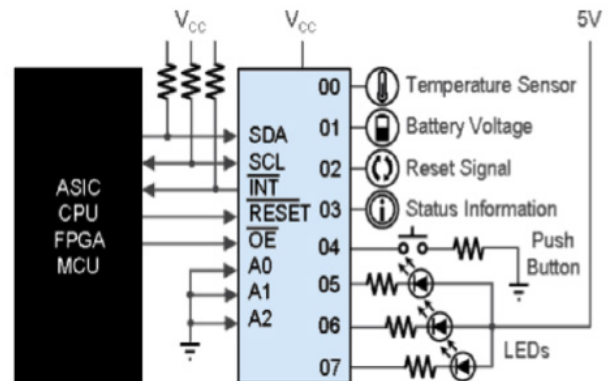

## GPIO Expanders Selection Guide

| Device      | # of Outputs | Quasi Output | Push-Pull Output | Internal Pull-up Resistor/ Current Source | Vcc Range (V) | I <sup>2</sup> C Max Frequency (kHz) | /OE | Hardware Reset | Interrupt Output | 2kbit EEPROM | 5-bit Multiplex/ 1-bit Latch EEPROM |
|-------------|--------------|--------------|------------------|---|---------------|--------------------------------------|-----|----------------|------------------|--------------|-------------------------------------|
| PCA9570     | 4            |              | Output Only      |   | 1.1 to 3.6    | 1000                                 |     |                |                  |              |                                     |
| PCA9536     | 4            |              | ✓                | ✓   | 2.3 to 5.5    | 400                                  |     |                |                  |              |                                     |
| PCA9537     | 4            |              | ✓                |   | 2.3 to 5.5    | 400                                  |     | ✓              | ✓                |              |                                     |
| PCA9571     | 8            |              | Output Only      |   | 1.1 to 3.6    | 1000                                 |     |                |                  |              |                                     |
| PCA6408A    | 8            |              |                  |   | 1.65 to 5.5   | 400                                  |     | ✓              | ✓                |              |                                     |
| PCA9538A    | 8            |              | ✓                |   | 1.65 to 5.5   | 400                                  |     | ✓              | ✓                |              |                                     |
| PCA9554B(C) | 8            |              | ✓                | ✓   | 1.65 to 5.5   | 400                                  |     |                | ✓                |              |                                     |
| PCA9500     | 8            | ✓            |                  | ✓   | 2.3 to 3.6    | 400                                  |     |                |                  | ✓            |                                     |
| PCA9501     | 8            | ✓            |                  | ✓   | 2.3 to 3.6    | 400                                  |     |                | ✓                | ✓            |                                     |
| PCA9502     | 8            |              | ✓                |   | 2.3 to 3.6    | 400                                  |     | ✓              | ✓                |              |                                     |
| PCA9557     | 8            |              | ✓                |   | 2.3 to 5.5    | 400                                  |     | ✓              |                  |              |                                     |
| PCA9558     | 8            | Open Drain   |                  |   | 2.3 to 5.5    | 400                                  |     |                |                  | ✓            | ✓                                   |
| PCA9670     | 8            | ✓            |                  | ✓   | 2.3 to 5.5    | 1000                                 |     | ✓              |                  |              |                                     |
| PCA8574(A)  | 8            | ✓            |                  | ✓   | 2.3 to 5.5    | 400                                  |     |                | ✓                |              |                                     |
| PCA9534     | 8            |              | ✓                |   | 2.3 to 5.5    | 400                                  |     |                | ✓                |              |                                     |
| PCA9538     | 8            |              | ✓                |   | 2.3 to 5.5    | 400                                  |     | ✓              | ✓                |              |                                     |
| PCA9554(A)  | 8            |              | ✓                | ✓   | 2.3 to 5.5    | 400                                  |     |                | ✓                |              |                                     |
| PCA9672     | 8            | ✓            |                  | ✓   | 2.3 to 5.5    | 1000                                 |     | ✓              | ✓                |              |                                     |
| PCA9674(A)  | 8            | ✓            |                  | ✓   | 2.3 to 5.5    | 1000                                 |     |                | ✓                |              |                                     |
| PCF8574(A)  | 8            | ✓            |                  | ✓   | 2.5 to 6.0    | 100                                  |     |                | ✓                |              |                                     |

| Device   | # of Outputs | Quasi Output | Push-Pull Output | Internal Pull-up Resistor/ Current Source | Vcc Range (V) | I <sup>2</sup> C Max Frequency (kHz) | /OE | Hardware Reset | Interrupt Output | 2kbit EEPROM | 5-bit Multiplex/ 1-bit Latch EEPROM |
|----------|--------------|--------------|------------------|---|---------------|--------------------------------------|-----|----------------|------------------|--------------|-------------------------------------|
| PCA6416A | 16           |              | ✓                |   | 1.65 to 5.5   | 400                                  |     | ✓              | ✓                |              |                                     |
| PCA9535A | 16           |              | ✓                |   | 1.65 to 5.5   | 400                                  |     |                | ✓                |              |                                     |
| PCA9539A | 16           |              | ✓                |   | 1.65 to 5.5   | 400                                  |     | ✓              | ✓                |              |                                     |
| PCA9555A | 16           |              | ✓                | ✓   | 1.65 to 5.5   | 400                                  |     |                | ✓                |              |                                     |
| PCA9671  | 16           | ✓            |                  | ✓   | 2.3 to 5.5    | 1000                                 |     | ✓              |                  |              |                                     |
| PCA8575  | 16           | ✓            |                  | ✓   | 2.3 to 5.5    | 400                                  |     |                | ✓                |              |                                     |
| PCA9535C | 16           | Open Drain   |                  |   | 2.3 to 5.5    | 400                                  |     |                | ✓                |              |                                     |
| PCA9535  | 16           |              | ✓                |   | 2.3 to 5.5    | 400                                  |     |                | ✓                |              |                                     |
| PCA9539  | 16           |              | ✓                |   | 2.3 to 5.5    | 400                                  |     | ✓              | ✓                |              |                                     |
| PCA9673  | 16           | ✓            |                  | ✓   | 2.3 to 5.5    | 1000                                 |     | ✓              | ✓                |              |                                     |
| PCA9675  | 16           | ✓            |                  | ✓   | 2.3 to 5.5    | 1000                                 |     |                | ✓                |              |                                     |
| PCA9555  | 16           |              | ✓                | ✓   | 2.3 to 5.5    | 400                                  |     |                | ✓                |              |                                     |
| PCF8575  | 16           | ✓            |                  | ✓   | 2.5 to 5.5    | 400                                  |     |                | ✓                |              |                                     |
| PCF8575C | 16           | Open Drain   |                  |   | 4.5 to 5.5    | 400                                  |     |                | ✓                |              |                                     |
| PCA9505  | 40           |              | ✓                | ✓   | 2.3 to 5.5    | 400                                  | ✓   | ✓              | ✓                |              |                                     |
| PCA9506  | 40           |              | ✓                |   | 2.3 to 5.5    | 400                                  | ✓   | ✓              | ✓                |              |                                     |
| PCA9698  | 40           | Open Drain   | ✓                |   | 2.3 to 5.5    | 1000                                 | ✓   | ✓              | ✓                |              |                                     |

## GPIO Expanders Agile I/O Selection Guide

| Device       | # of Outputs | Quasi Output | Push-Pull Output | Internal Pull-up Resistor/ Current Source | Vcc Range (V) | I <sup>2</sup> C Max Frequency (kHz) | Hardware Reset | Interrupt Status | Interrupt Output | Voltage Translating Capability |
|--------------|--------------|--------------|------------------|---|---------------|--------------------------------------|----------------|------------------|------------------|--------------------------------|
| PCAL6408A    | 8            | Open Drain   | ✓                | ✓   | 1.65 to 5.5   | 400                                  | ✓              | ✓                | ✓                | ✓                              |
| PCAL9538A    | 8            | Open Drain   | ✓                | ✓   | 1.65 to 5.5   | 400                                  | ✓              | ✓                | ✓                |                                |
| PCAL9554B(C) | 8            | Open Drain   | ✓                | ✓   | 1.65 to 5.5   | 400                                  |                | ✓                | ✓                |                                |
| PCAL6416A    | 16           | Open Drain   | ✓                | ✓   | 1.65 to 5.5   | 400                                  | ✓              | ✓                | ✓                | ✓                              |
| PCAL9535A    | 16           | Open Drain   | ✓                | ✓   | 1.65 to 5.5   | 400                                  |                | ✓                | ✓                |                                |
| PCAL9539A    | 16           | Open Drain   | ✓                | ✓   | 1.65 to 5.5   | 400                                  | ✓              | ✓                | ✓                |                                |
| PCAL9555A    | 16           | Open Drain   | ✓                | ✓   | 1.65 to 5.5   | 400                                  |                | ✓                | ✓                |                                |

### Unique "Agile I/O" Features

Incorporating many highly useful functions commonly added in system applications, the new I<sup>2</sup>C Agile I/O expanders offer the following standard integrated hardware features:

- An interrupt pin that reports back to the control processor when an input has changed state
- A hardware reset pin to return the device to its default state without powering down the part
- Two power-supply pins to enable simple level-shifting between different voltage domains (PCA(L)64XX only)

In addition, the Agile I/O expanders include important software-programmable features, including:

- A latched input to retain the input state
- Internal pull-up and pull-down resistors (PCA9554B(C) and PCA9555A default pull-up ON)
- An interrupt mask which reduces interrupt traffic to the microcontroller and improves interrupt service response
- Interrupt register reports to identify which input actually caused an interrupt
- An output drive strength control to minimize system noise when multiple outputs switch simultaneously

## Need a Simple, Low-cost Way to Add I/O and Voltage Level Shifting to your I<sup>2</sup>C Design?

NXP's low-voltage translating I/O expander is the solution.

This part provides additional I/O while keeping interconnections to a minimum.

It also simplifies interconnection of processors running at one voltage level to I/O devices operating at a different voltage level.



### PCAL6416A GPIO FEATURES

- ▶ 16-bit general purpose I/O expansion
- ▶ 400 MHz Fast mode I<sup>2</sup>C-bus
- ▶ Independent operating supply voltage of 1.65 V to 5.5 V for both I/O and I<sup>2</sup>C-bus interface
- ▶ Bidirectional voltage-level translation and GPIO expansion
- ▶ Schmitt trigger action for slow input transition and better switching noise immunity at SCL/SDA inputs
- ▶ Latched outputs for directly driving LEDs
- ▶ Low standby current consumption

## Thermal Sensors and Voltage Management

NXP offers a wide range of temperature sensors to support system reliability and enhance performance. Sensor options include: local-only, local and remote, and serial presence detect (SPD).

### Features

- Wide supply range coverage (1.7 to 5.5V)
- Wide operating temperature range (-55 to 125 °C)
- Low power and standby current
- Programmable temperature set points
- Standby mode and one-shot conversion
- Programmable fault queue
- One remote channel
- One thermal alarm output

### Applications

- Desktop and notebook computers
- Servers
- Power supplies
- Enterprise communication

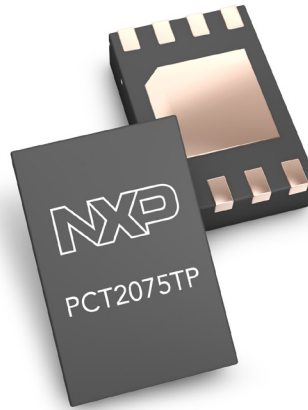

### Thermal Sensors and Voltage Management Selection Guide

| Device  | Fan Control Output | Local Sensing Accuracy (°C) | Remote Sensing Accuracy (°C) | A/D Resolution (°C/#bits) | Supply Range (V) | Supply Operating Current (µA) | Supply Operating Current (µA) (typical 25° C/max 125° C) | Package Options                      |
|---------|--------------------|-----------------------------|------------------------------|---------------------------|------------------|-------------------------------|--|--------------------------------------|
| PCT1075 |                    | ±0.5                        |                              | 0.0625/12                 | 2.7 to 5.5       | 400                           | < 0.1/20   | SO-8<br>TSSOP-8<br>HWSON-8<br>TSOP6  |
| SE98A   |                    | ±1                          |                              | 0.125/11                  | 1.7 to 3.6       | 400                           | < 0.1/5  | TSSOP-8<br>HWSON-8                   |
| PCT2075 |                    | ±1                          |                              | 0.125/11                  | 2.7 to 5.5       | 400                           | < 0.1/20   | SO-8<br>TSSOP-8<br>HWSON-8<br>TSOP6  |
| SE95    |                    | ±1                          |                              | 0.03125/13                | 2.8 to 5.5       | 1000                          | < 7.5/NA   | SO-8<br>TSSOP-8<br>WAFER             |
| SE97B   |                    | ±1                          |                              | 0.125/11                  | 3.0 to 3.6       | 400                           | < 0.1/10   | HWSON-8                              |
| LM75A*  |                    | ±2                          |                              | 0.125/11                  | 2.8 to 5.5       | 1000                          | < 3.5/NA   | SO-8<br>TSSOP-8                      |
| LM75B   |                    | ±2                          |                              | 0.125/11                  | 2.8 to 5.5       | 300                           | < 0.2/1  | SO-8<br>TSSOP-8<br>XSON-8<br>HWSON-8 |
| SA56004 | 1                  | ±2                          | ±1                           | 0.125/11                  | 3.0 to 3.6       | 500                           | 10/NA  | SO-8<br>TSSOP-8<br>HWSON-8           |
| NE1617A |                    | ±2                          | ±3                           | 1.0/8                     | 3.0 to 5.5       | 70                            | 3/10   | QSOP-8                               |

\*Not recommended for new designs, use LM75B or PCT2075 instead.



## Precise Temperature Monitoring Made Simple

NXP's I<sup>2</sup>C-bus controlled temperature sensors offer high-resolution solutions for your thermal management needs.

Ideally suited for personal computers, industrial controllers, and other electronic equipment.



### **PCT2075 THERMAL SENSOR FEATURES**

- ▶ Pin-for-pin replacement for industry standard part LM75
- ▶ 11-bit ADC with enhanced temperature resolution of 0.125 °C
- ▶ Temperature accuracy of  $\pm 1$  °C from -25 °C to +100 and  $\pm 2$  from -55 °C to +125 °C
- ▶ Power supply input range of 2.7–5.5 V
- ▶ Programmable temperature threshold and hysteresis set points
- ▶ Shutdown mode for power conservation
- ▶ Small form factor packages



## LCD Display Drivers

NXP offers a wide range of LCD Segment, Character and Graphic Drivers for the most challenging applications in automotive, industrial, and consumer. All latest NXP LCD drivers are specifically designed for — but not limited to — driving high-contrast, true black background Vertical Alignment (VA) displays which offer a very wide viewing angle. Automotive AEC-Q100 compliant qualification on a wide range of devices ensures highest robustness and reliability under harshest conditions. Available as cased devices in a package for Surface Mount Device (SMD) application or as bare die with gold bumps for Chip-On-Glass (COG) application.



### Features

- Wide supply voltage range
- Wide VLCD voltage range
- Low power consumption
- Programmable multiplex rates
- Wide operating temperature range up to +105 °C (selected devices)
- On-chip VLCD generation (charge pump) (selected devices)
- On-chip VLCD temperature compensation (selected devices)
- Programmable frame frequency (selected devices)
- AEC-Q100 compliant automotive qualification (selected devices)

### Applications

- Industrial
  - e-meter (electricity, gas, water)
  - White goods
  - Home appliance
  - Test & measurement systems
  - Machine control systems
  - Point of Sales (POS) terminals
- Automotive
  - Instrument cluster
  - Climate control unit
  - Car radio
  - Tachographs
- Consumer
  - Handheld electronics
  - Battery operated equipment
  - General purpose display modules
- Medical and health care

## LCD Segment Drivers

| Device     | Max number of elements | Number of elements at Multiplex Rate |         |         |         |         |         |         | VDD       |           | VLCD      |           | Frame Frequency (Hz) | On-Chip VLCD Generation (Charge Pump) | On Chip VLCD Temperature Compensation | Tamb       |            | Package                   | AEC-Q100 compliant |
|------------|------------------------|--------------------------------------|---------|---------|---------|---------|---------|---------|-----------|-----------|-----------|-----------|----------------------|---------------------------------------|---------------------------------------|------------|------------|---------------------------|--------------------|
|            |                        | MUX 1:1                              | MUX 1:2 | MUX 1:3 | MUX 1:4 | MUX 1:6 | MUX 1:8 | MUX 1:9 | [min] (V) | [max] (V) | [min] (V) | [max] (V) |                      |                                       |                                       | [min] (°C) | [max] (°C) |                           |                    |
| PCF85162T  | 128                    | 32                                   | 64      | 96      | 128     |         |         |         | 1.8       | 5.5       | 2.5       | 6.5       | 82                   | N                                     | N                                     | -40        | 85         | TSSOP48                   | N                  |
| PCA85162T  | 128                    | 32                                   | 64      | 96      | 128     |         |         |         | 1.8       | 5.5       | 2.5       | 8         | 110                  | N                                     | N                                     | -40        | 95         | TSSOP48                   | Y                  |
| PCF85176T  | 160                    | 40                                   | 80      | 120     | 160     |         |         |         | 1.8       | 5.5       | 2.5       | 6.5       | 82                   | N                                     | N                                     | -40        | 85         | TSSOP56                   | N                  |
| PCA85176T  | 160                    | 40                                   | 80      | 120     | 160     |         |         |         | 1.8       | 5.5       | 2.5       | 8         | 82                   | N                                     | N                                     | -40        | 95         | TSSOP56                   | Y                  |
| PCF85176H  | 160                    | 40                                   | 80      | 120     | 160     |         |         |         | 1.8       | 5.5       | 2.5       | 6.5       | 82                   | N                                     | N                                     | -40        | 85         | TQFP64                    | N                  |
| PCA85176H  | 160                    | 40                                   | 80      | 120     | 160     |         |         |         | 1.8       | 5.5       | 2.5       | 8         | 82                   | N                                     | N                                     | -40        | 95         | TQFP64                    | Y                  |
| PCF85134HL | 240                    | 60                                   | 120     | 180     | 240     |         |         |         | 1.8       | 5.5       | 2.5       | 6.5       | 82                   | N                                     | N                                     | -40        | 85         | LQFP80                    | N                  |
| PCA85134H  | 240                    | 60                                   | 120     | 180     | 240     |         |         |         | 1.8       | 5.5       | 2.5       | 8         | 82                   | N                                     | N                                     | -40        | 95         | LQFP80                    | Y                  |
| PCF8536AT  | 320                    |                                      |         |         | 176     | 252     | 320     |         | 1.8       | 5.5       | 2.5       | 9         | 60-300 <sup>1</sup>  | N                                     | N                                     | -40        | 85         | TSSOP56                   | N                  |
| PCA8536AT  | 320                    |                                      |         |         | 176     | 252     | 320     |         | 1.8       | 5.5       | 2.5       | 9         | 60-300 <sup>1</sup>  | N                                     | N                                     | -40        | 95         | TSSOP56                   | Y                  |
| PCF8537AH  | 352                    | 44                                   | 88      |         | 176     | 276     | 352     |         | 1.8       | 5.5       | 2.5       | 9         | 60-300 <sup>1</sup>  | Y                                     | Y                                     | -40        | 85         | TQFP64                    | N                  |
| PCA8537AH  | 352                    | 44                                   | 88      |         | 176     | 276     | 352     |         | 1.8       | 5.5       | 2.5       | 9         | 60-300 <sup>1</sup>  | Y                                     | Y                                     | -40        | 95         | TQFP64                    | Y                  |
| PCA9620H   | 480                    | 60                                   | 120     |         | 240     | 320     | 480     |         | 2.5       | 5.5       | 2.5       | 9         | 60-300 <sup>1</sup>  | Y                                     | Y                                     | -40        | 105        | LQFP80                    | Y                  |
| PCA9620U   | 480                    | 60                                   | 120     |         | 240     | 320     | 480     |         | 2.5       | 5.5       | 2.5       | 9         | 60-300 <sup>1</sup>  | Y                                     | Y                                     | -40        | 105        | Bare die                  | Y                  |
| PCF8576DU  | 160                    | 40                                   | 80      | 120     | 160     |         |         |         | 1.8       | 5.5       | 2.5       | 6.5       | 77                   | N                                     | N                                     | -40        | 85         | Gold-bumped die, bare die | N                  |
| PCA8576DU  | 160                    | 40                                   | 80      | 120     | 160     |         |         |         | 1.8       | 5.5       | 2.5       | 6.5       | 77                   | N                                     | N                                     | -40        | 85         | Gold-bumped die           | Y                  |

1. SW programmable. 2. HW selectable. 3. Release H1 2013. 4. Release H2 2013.

| Device                 | Max number of elements | Number of elements at Multiplex Rate |         |         |         |         |         |         | VDD       |           | VLCD      |           | Frame Frequency (Hz) | On-Chip VLCD Generation (Charge Pump) | On Chip VLCD Temperature Compensation | Tamb       |            | Package         | AEC-Q100 compliant |
|------------------------|------------------------|--------------------------------------|---------|---------|---------|---------|---------|---------|-----------|-----------|-----------|-----------|----------------------|---------------------------------------|---------------------------------------|------------|------------|-----------------|--------------------|
|                        |                        | MUX 1:1                              | MUX 1:2 | MUX 1:3 | MUX 1:4 | MUX 1:6 | MUX 1:8 | MUX 1:9 | [min] (V) | [max] (V) | [min] (V) | [max] (V) |                      |                                       |                                       | [min] (°C) | [max] (°C) |                 |                    |
| PCA8576FU <sup>4</sup> | 160                    | 40                                   | 80      | 120     | 160     |         |         |         | 1.8       | 5.5       | 2.5       | 6.5       | 200                  | N                                     | N                                     | -40        | 95         | Gold-bumped die | Y                  |
| PCF85133U              | 320                    | 80                                   | 160     | 240     | 320     |         |         |         | 1.8       | 5.5       | 2.5       | 6.5       | 82/110 <sup>2</sup>  | N                                     | N                                     | -40        | 85         | Gold-bumped die | N                  |
| PCA85133U              | 320                    | 80                                   | 160     | 240     | 320     |         |         |         | 1.8       | 5.5       | 2.5       | 8         | 82/110 <sup>2</sup>  | N                                     | N                                     | -40        | 95         | Gold-bumped die | Y                  |
| PCA85233U <sup>4</sup> | 320                    | 80                                   | 160     | 240     | 320     |         |         |         | 1.8       | 5.5       | 2.5       | 8         | 150/220 <sup>2</sup> | N                                     | N                                     | -40        | 95         | Gold-bumped die | Y                  |
| PCF85132U              | 640                    | 160                                  | 320     | 480     | 640     |         |         |         | 1.8       | 5.5       | 1.8       | 8         | 60-90 <sup>1</sup>   | N                                     | N                                     | -40        | 85         | Gold-bumped die | N                  |
| PCA85132U              | 640                    | 160                                  | 320     | 480     | 640     |         |         |         | 1.8       | 5.5       | 1.8       | 8         | 60-90 <sup>1</sup>   | N                                     | N                                     | -40        | 95         | Gold-bumped die | Y                  |
| PCA85232U              | 640                    | 160                                  | 320     | 480     | 640     |         |         |         | 1.8       | 5.5       | 1.8       | 8         | 117-176 <sup>1</sup> | N                                     | N                                     | -40        | 95         | Gold-bumped die | Y                  |
| PCF8538U <sup>3</sup>  | 918                    | 102                                  | 204     |         | 408     | 612     | 816     | 918     | 2.5       | 5.5       | 4         | 12        | 45-300 <sup>1</sup>  | Y                                     | Y                                     | -40        | 85         | Gold-bumped die | N                  |
| PCA8538U <sup>3</sup>  | 918                    | 102                                  | 204     |         | 408     | 612     | 816     | 918     | 2.5       | 5.5       | 4         | 12        | 45-300 <sup>1</sup>  | Y                                     | Y                                     | -40        | 105        | Gold-bumped die | Y                  |

1. SW programmable. 2. HW selectable. 3. Release H1 2013. 4. Release H2 2013.

## LCD Character Drivers

| Device                 | Number of Lines x Number of Characters |        | Number of Icons | Character Set | VDD1      |           | VDD2      |           | VLCD      |           | Frame Frequency (Hz) | On-Chip VLCD Generation (Charge Pump) | On Chip VLCD Temperature Compensation | Tamb       |            | Package         | AEC-Q100 compliant |
|------------------------|--|--------|-----------------|---------------|-----------|-----------|-----------|-----------|-----------|-----------|----------------------|---------------------------------------|---------------------------------------|------------|------------|-----------------|--------------------|
|                        |  |        |                 |               | [min] (V) | [max] (V) | [min] (V) | [max] (V) | [min] (V) | [max] (V) |                      |                                       |                                       | [min] (°C) | [max] (°C) |                 |                    |
| PCF2113AU              | 1 x 24                                 | 2 x 12 | 120             | A             | 1.8       | 5.5       | 2.2       | 4         | 2.2       | 6.5       | 95                   | Y                                     | Y                                     | -40        | 85         | Gold-bumped die | N                  |
| PCF2113DU              | 1 x 24                                 | 2 x 12 | 120             | D             | 1.8       | 5.5       | 2.2       | 4         | 2.2       | 6.5       | 95                   | Y                                     | Y                                     | -40        | 85         | Gold-bumped die | N                  |
| PCF2113EU              | 1 x 24                                 | 2 x 12 | 120             | E             | 1.8       | 5.5       | 2.2       | 4         | 2.2       | 6.5       | 95                   | Y                                     | Y                                     | -40        | 85         | Gold-bumped die | N                  |
| PCF2113WU              | 1 x 24                                 | 2 x 12 | 120             | W             | 1.8       | 5.5       | 2.2       | 4         | 2.2       | 6.5       | 95                   | Y                                     | Y                                     | -40        | 85         | Gold-bumped die | N                  |
| PCF2116AU              | 1 x 24                                 | 2 x 24 | 4 x 12          | A             | 2.5       | 6         | 2.5       | 6         | 3.5       | 9         | 65                   | Y                                     | N                                     | -40        | 85         | Gold-bumped die | N                  |
| PCF2116CU              | 1 x 24                                 | 2 x 24 | 4 x 12          | C             | 2.5       | 6         | 2.5       | 6         | 3.5       | 9         | 65                   | Y                                     | N                                     | -40        | 85         | Gold-bumped die | N                  |
| PCF2119AU              | 1 x 32                                 | 2 x 16 | 160             | A             | 1.5       | 5.5       | 2.2       | 4         | 2.2       | 6.5       | 95                   | Y                                     | Y                                     | -40        | 85         | Gold-bumped die | N                  |
| PCF2119DU              | 1 x 32                                 | 2 x 16 | 160             | D             | 1.5       | 5.5       | 2.2       | 4         | 2.2       | 6.5       | 95                   | Y                                     | Y                                     | -40        | 85         | Gold-bumped die | N                  |
| PCF2119FU              | 1 x 32                                 | 2 x 16 | 160             | F             | 1.5       | 5.5       | 2.2       | 4         | 2.2       | 6.5       | 95                   | Y                                     | Y                                     | -40        | 85         | Gold-bumped die | N                  |
| PCF2119IU              | 1 x 32                                 | 2 x 16 | 160             | I             | 1.5       | 5.5       | 2.2       | 4         | 2.2       | 6.5       | 95                   | Y                                     | Y                                     | -40        | 85         | Gold-bumped die | N                  |
| PCF2119RU              | 1 x 32                                 | 2 x 16 | 160             | R             | 1.5       | 5.5       | 2.2       | 4         | 2.2       | 6.5       | 95                   | Y                                     | Y                                     | -40        | 85         | Gold-bumped die | N                  |
| PCF2119SU              | 1 x 32                                 | 2 x 16 | 160             | S             | 1.5       | 5.5       | 2.2       | 4         | 2.2       | 6.5       | 95                   | Y                                     | Y                                     | -40        | 85         | Gold-bumped die | N                  |
| PCF2117RU <sup>2</sup> | 1 x 40                                 | 2 x 20 | 200             | R             | 2.5       | 5.5       | 2.5       | 5.5       | 4         | 16        | 45-300 <sup>1</sup>  | Y                                     | Y                                     | -40        | 85         | Gold-bumped die | N                  |
| PCA2117RU <sup>2</sup> | 1 x 40                                 | 2 x 20 | 200             | R             | 2.5       | 5.5       | 2.5       | 5.5       | 4         | 16        | 45-300 <sup>1</sup>  | Y                                     | Y                                     | -40        | 105        | Gold-bumped die | Y                  |
| PCF2117SU <sup>2</sup> | 1 x 40                                 | 2 x 20 | 200             | S             | 2.5       | 5.5       | 2.5       | 5.5       | 4         | 16        | 45-300 <sup>1</sup>  | Y                                     | Y                                     | -40        | 85         | Gold-bumped die | N                  |
| PCA2117SU <sup>2</sup> | 1 x 40                                 | 2 x 20 | 200             | S             | 2.5       | 5.5       | 2.5       | 5.5       | 4         | 16        | 45-300 <sup>1</sup>  | Y                                     | Y                                     | -40        | 105        | Gold-bumped die | Y                  |

1. SW programmable. 2. Release H2 2013.

## LCD Graphic Drivers

| Device                | Max Display Resolution Rows x Cols | Multiplex Rates                    | VDD1      |           | VDD2      |           | VLCD      |           | Frame Frequency (Hz) | On-Chip VLCD Generation (Charge Pump) | On Chip VLCD Temperature Compensation | Tamb       |            | Package         | AEC-Q100 compliant |
|-----------------------|------------------------------------|------------------------------------|-----------|-----------|-----------|-----------|-----------|-----------|----------------------|---------------------------------------|---------------------------------------|------------|------------|-----------------|--------------------|
|                       |                                    |                                    | [min] (V) | [max] (V) | [min] (V) | [max] (V) | [min] (V) | [max] (V) |                      |                                       |                                       | [min] (°C) | [max] (°C) |                 |                    |
| PCF8539U <sup>2</sup> | 18 x 100                           | Mux 1:12; Mux 1:18                 | 2.5       | 5.5       | 2.5       | 5.5       | 4         | 16        | 45-300 <sup>1</sup>  | Y                                     | Y                                     | -40        | 85         | Gold-bumped die | N                  |
| PCA8539U <sup>2</sup> | 18 x 100                           | Mux 1:12; Mux 1:18                 | 2.5       | 5.5       | 2.5       | 5.5       | 4         | 16        | 45-300 <sup>1</sup>  | Y                                     | Y                                     | -40        | 105        | Gold-bumped die | Y                  |
| PCF8531U              | 34 x 128 or 33 x 128 + 128 icons   | Mux 1:17, Mux 1:26, Mux 1:34       | 1.8       | 5.5       | 2.5       | 4.5       | 4         | 9         | 66                   | Y                                     | Y                                     | -40        | 85         | Gold-bumped die | N                  |
| PCF8811U              | 80 x 128 or 79 x 129 + 128 icons   | Mux 1:16 to Mux 1:80 in steps of 8 | 2         | 3.3       | 1.8       | 3.3       | 3         | 9         | 30-60 <sup>1</sup>   | Y                                     | Y                                     | -40        | 85         | Gold-bumped die | N                  |

1. SW programmable. 2. Release H2 2013.

## Fully Featured LCD Drivers for High-Contrast Vertical Alignment (VA) Displays

Specifically designed for high-contrast, true black background Vertical Alignment (VA) displays which offer a very wide viewing angle.

Automotive AEC-Q100 compliant qualification for highest robustness and reliability under harshest conditions.

Fully featured with on-chip VLCD generation and on-chip VLCD temperature compensation.

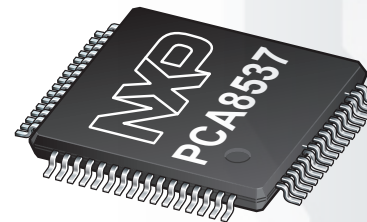

### PCA8537 LCD DRIVER FEATURES

- ▶ 352-segment driver (44, 88, 176, 276 or 352 segments)
- ▶ Programmable frame frequency from 60 to 300Hz
- ▶ Extended VLCD supply voltage range to 9V
- ▶ On-chip VLCD generation (charge pump)
- ▶ On-chip VLCD temperature compensation
- ▶ Extended temperature range to +95 °C
- ▶ AEC-Q100 compliant
- ▶ TQFP64 package

## Clocks and Real Time Clocks

NXP offers a variety of real-time clocks to suit the many applications requiring accurate time keeping. Options include ultra-low power, high-temperature tolerant, temperature compensated, and high-accuracy versions.

### Features

- All addresses and data transferred serially via I<sup>2</sup>C-bus

### Applications

- Mobile telephones
- Portable instruments
- Electronic metering
- Battery-powered products



### Clocks and Real Time Clocks Selection Guide

| Device         | Bus                  | Feature   |
|----------------|----------------------|---|
| PCA8802        | I <sup>2</sup> C Fm  | Ultra low power Smartcard; integrated counter for initiating one time password generation |
| PCF8523        | I <sup>2</sup> C Fm+ | Ultra low power with loss of main power detect and auto battery switch over               |
| PCF8563        | I <sup>2</sup> C Fm  | Ultra low power clock/calendar  |
| PCF85063       | I <sup>2</sup> C Fm  | Tiny RTC with 30s, 60s interrupt  |
| PCF85063A      | I <sup>2</sup> C Fm  | Tiny RTC with alarm and 30s, 60s interrupt  |
| PCA8565        | I <sup>2</sup> C Fm  | High temperature (-40°C – +125°C) clock/calendar  |
| PCF8583        | I <sup>2</sup> C     | Clock/calendar resolution 0.01 s with 256x8 SRAM  |
| PCF2127A       | I <sup>2</sup> C Fm  | High-accuracy, low-voltage with 512x8 RAM; temperature compensated                        |
| PCA/PCF2129(A) | I <sup>2</sup> C Fm  | High accuracy; temperature compensated  |

## Precision Timekeeping Doesn't Have to Consume Lots of Power

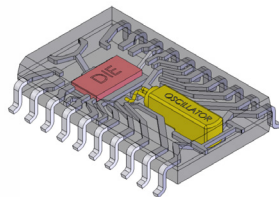

NXP's PCA2129 Real Time Clock provides precision timekeeping for automotive, electronic metering, GPS equipment, or any other application that requires accurate process timing.

### PCA2129 REAL TIME CLOCK FEATURES

- ▶ AEC-Q100 compliance for automotive applications
- ▶ Typical accuracy of  $\pm 3$  ppm from -30 °C to +80 °C
- ▶ 32.768 kHz quartz crystal and oscillator integrated into one convenient package
- ▶ Battery backed output voltage and low battery detection
- ▶ Temperature compensated crystal oscillator with integrated capacitors
- ▶ Year, month, day, weekday, hours, minutes, seconds, and leap year correction
- ▶ Programmable interrupts and watchdog timer
- ▶ Clock operating voltage of 1.8 V to 4.2 V



## Tiny Serial Analog-to-Digital and Digital-to-Analog Converters

I<sup>2</sup>C Analog-to-Digital (A/D) and Digital-to-Analog (D/A) converters provide a way to convert between digital and analog signals and send the information via the I<sup>2</sup>C-bus.

### Features

- Convert four different analog voltages to digital values
- Transmit converted data on an I<sup>2</sup>C-bus for processing by microprocessor/controller
- Generate one analog voltage output from 8-bit digital value

### Applications

- Record analog information such as temperature, pressure, battery level, signal strength
- Convert from digital signals to analog voltages for LCD contrast or buzzer control

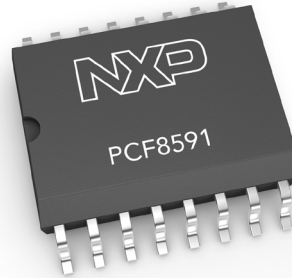

### Tiny Serial ADC and DAC Selection Guide

| Device  | A/D | D/A | # Bits | I <sup>2</sup> C-bus Frequency | Maximum Conversion Rate (kHz) |
|---------|-----|-----|--------|--------------------------------|-------------------------------|
| PCF8591 | ✓   | ✓   | 8      | 100 kHz                        | 11                            |

## Add Data Conversion Functionality with Minimal Impact

NXP's PCF8591 provides 8-bit digital-to-analog and analog-to-digital conversion in a single chip, single supply, low-power device.

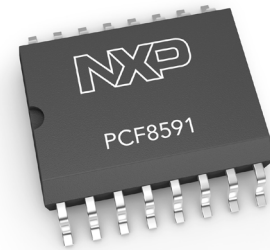

### PCF8591 A/D AND D/A CONVERTER FEATURES

- ▶ 8-bit CMOS data acquisition device using successive approximation A/D conversion and multiplying D/A conversion
- ▶ 4 analog inputs programmable as single-ended or differential
- ▶ 1 analog output
- ▶ Serial input/output via I<sup>2</sup>C-bus
- ▶ Addressable via 3 hardware address pins
- ▶ Sampling rate given by I<sup>2</sup>C-bus speed
- ▶ Auto-incremented channel selection
- ▶ On-chip track and hold circuit
- ▶ Single operating supply voltage of 2.5 V to 6 V



## Multiplexers and Switches

I<sup>2</sup>C-bus multiplexers and switches provide capacitive isolation when connecting an upstream I<sup>2</sup>C-bus to a desired combination of downstream buses. The software-controlled multiplexers and switches break the I<sup>2</sup>C-bus into two, four, or eight sub-branches. Multiplexers allow selection of only one downstream branch at a time, while switches allow selection of any individual downstream sub-branch or combination of downstream sub-branches.

### Features

- Interrupt
- Hardware reset
- 2.3–5.5 V operating voltage
- 5 V tolerant input/outputs
- -40–85 °C operating temperature range
- 0–400 kHz operating frequency
- I<sup>2</sup>C and SMBus compatible

### Applications

- Connection of I<sup>2</sup>C devices that operate at different voltage levels but share a common bus
- Expanded ability to use multiple devices that share a common I<sup>2</sup>C address
- Providing voltage level shifting
- Isolating devices when not in use to reduce overall system capacitive loading

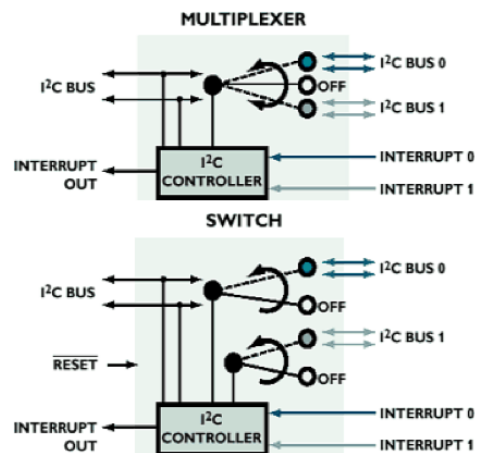

## Multiplexers and Switches Selection Guide

| Device                  | Multiplexer (In/Out) | Switch (In/Out) | I <sup>2</sup> C-bus # of Addresses | Interrupt (IN-OUT) | Hardware Reset | Packages  |             |           |       |               |
|-------------------------|----------------------|-----------------|-------------------------------------|--------------------|----------------|-----------|-------------|-----------|-------|---------------|
|                         |                      |                 |                                     |                    |                | Pin Count | SO (Narrow) | SO (Wide) | TSSOP | XSON or HVQFN |
| PCA9540B                | 1-2                  |                 | 1                                   |                    |                | 8         | D           |           | DP    | GD            |
| PCA9541A                | 2-1                  |                 | 16                                  | 1-2                | ✓              | 16        | D           |           | PW    | BS            |
| PCA9542A                | 1-2                  |                 | 8                                   | 2-1                |                | 14        | D           |           | PW    |               |
| PCA9543A/B <sup>1</sup> |                      | 1-2             | 4                                   | 2-1                | ✓              | 14        | D           |           | PW    |               |
| PCA9544A                | 1-4                  |                 | 8                                   | 4-1                |                | 20        |             | D         | PW    | BS            |
| PCA9545A/B <sup>2</sup> |                      | 1-4             | 4                                   | 4-1                | ✓              | 20        |             | D         | PW    | BS            |
| PCA9546A                |                      | 1-4             | 8                                   |                    | ✓              | 16        | D           |           | PW    | BS            |
| PCA9547                 | 1-8                  |                 | 8                                   |                    | ✓              | 24        |             | D         | PW    | BS            |
| PCA9548A                |                      | 1-8             | 8                                   |                    | ✓              | 24        |             | D         | PW    | BS            |
| PCA9646 <sup>3</sup>    |                      | 1-4             | 8                                   |                    | ✓              | 16        | D           |           | PW    |               |

1. PCA9543A and PCA9543B are identical except for the fixed addresses allowing four of each version on the same bus

2. PCA9545A and PCA9545B are identical except for the fixed addresses allowing four of each version on the same bus

3. No offset bus buffer isolates capacitance to each channel, operates to 1 MHz on Fm+ bus

## Expand the Reach of your I<sup>2</sup>C-based Application

Avoid complete system redesign: address capacity via bus switches.

NXP's I<sup>2</sup>C-bus switches allow selection of any downstream branch, even those operating at different voltage levels.

Plus, they reduce overall system capacitive loading by isolating devices not currently in use.

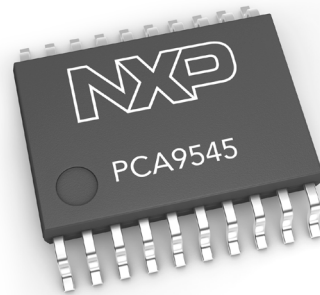

### PCA9545A BUS SWITCH FEATURES

- ▶ Voltage level translation between 1.8 V, 2.5 V, 3.3 V, and 5 V buses
- ▶ 1-of-4 bidirectional translating switches
- ▶ 0-400 kHz clock frequency
- ▶ 5 V tolerant inputs
- ▶ Channel selection via I<sup>2</sup>C-bus, in any combination
- ▶ No glitch power-up
- ▶ Hot insertion support
- ▶ Power supply operating voltage range of 2.3 V to 5.5 V



## Bus Buffers and Voltage Translators

Bus buffers allow designers to expand use of the I<sup>2</sup>C-bus beyond the 400 pF maximum capacitive loading allowed by the I<sup>2</sup>C specification, allowing bidirectional communication without a direction pin.

### Features

- Voltage translation
- Opto-electrical isolation
- Bus buffering
- Bus isolation/multiplexing

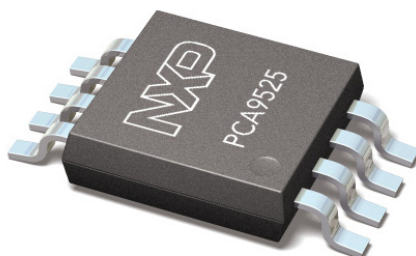

### Applications

- Add more I<sup>2</sup>C or SMBus devices in the same system
- Extend the reach of I<sup>2</sup>C or SMBus over longer distances
- Isolate an I<sup>2</sup>C or SMBus segment
- Translate voltage levels to allow devices with different voltage requirements to work on the same bus
- Electrically isolate the I<sup>2</sup>C-bus
- Support multi-point distribution of the I<sup>2</sup>C-bus

## Bus Buffers and Voltage Translators Selection Guide

| Device   | Type of Capacitance Isolation Buffer | Description                                | I <sup>2</sup> C-bus (V) (Left) | I <sub>OL</sub> (mA) (Left) | I <sup>2</sup> C-bus (V) (Right) | I <sub>OL</sub> (mA) (Right) | # of Pins | Typical Distance | Level Translation Capability |
|----------|--------------------------------------|--|---------------------------------|-----------------------------|----------------------------------|------------------------------|-----------|------------------|------------------------------|
| P82B715  | None - Amplifier                     | Fm HV bus extender                         | 0 to 12V                        | 3                           | 0 to 12V                         | 30                           | 8         | > 20 m           | None                         |
| PCA9510A | Incremental Offset                   | Fm hot-swap bus buffer (no RTA)            | 2.7 to 5.5V                     | 3                           | 2.7 to 5.5V                      | 3                            | 8         | On Card          | None                         |
| PCA9511A | Incremental Offset                   | Fm hot swap-bus buffer                     | 2.7 to 5.5V                     | 3                           | 2.7 to 5.5V                      | 3                            | 8         | On Card          | None                         |
| PCA9512A | Incremental Offset                   | Fm VLT hot swap bus buffer                 | 2.7 to 5.5V                     | 3                           | 2.7 to 5.5V                      | 3                            | 8         | On Card          | 2 Supplies                   |
| PCA9513A | Incremental Offset                   | Fm hot-swap bus buffer (92 uA CS)          | 2.7 to 5.5V                     | 3                           | 2.7 to 5.5V                      | 3                            | 8         | On Card          | None                         |
| PCA9514A | Incremental Offset                   | Fm hot-swap bus buffer (0.8 V offset)      | 2.7 to 5.5V                     | 3                           | 2.7 to 5.5V                      | 3                            | 8         | On Card          | None                         |
| PCA9521  | Incremental Offset                   | 1 MHz HV Incremental Offset bus buffer     | 1.3 to 10V                      | 6                           | 1.3 to 10V                       | 6                            | 8         | < 3 m            | Over voltage tolerant        |
| PCA9522  | Incremental Offset                   | 1 MHz HV hot-swap bus buffer               | 1.3 to 10V                      | 6                           | 1.3 to 10V                       | 6                            | 8         | < 3 m            | Over voltage tolerant        |
| PCA9525  | No offset Buffer                     | 1 MHz bus repeater                         | 1.4 to 5.5V                     | 4                           | 1.4 to 5.5V                      | 4                            | 8         | < 3 m            | None                         |
| PCA9605  | No offset Buffer                     | Fm+ bus repeater                           | 1.4 to 5.5V                     | 30                          | 1.4 to 5.5V                      | 30                           | 8         | < 20 m           | None                         |
| PCA9646  | No offset Buffer                     | 4-channel Fm+ buffer/switch with RST       | 1.4 to 5.5V                     | 30                          | 1.4 to 5.5V                      | 30                           | 16        | < 20 m           | None                         |
| P82B96   | Static Offset                        | Fm HV for long distance and opto-isolation | 3.2 to 15V                      | 3                           | 1.4 to 15V                       | 30                           | 8         | > 20 m           | Over voltage tolerant        |
| PCA9507  | Static Offset                        | Fm VLT DDC buffer with accelerator         | 2.7 to 5.5V                     | 6                           | 2.7 to 5.5V                      | 6                            | 8         | < 20 m           | 2 Supplies                   |
| PCA9508  | Static Offset                        | Fm VLT hot-swap bus repeater               | 0.9 to 5.5V                     | 6                           | 2.7 to 5.5V                      | 6                            | 8         | < 3 m            | 2 Supplies                   |
| PCA9509  | Static Offset                        | Fm 1.0V LV VLT with current source         | 1 to 4V                         | 6                           | 3 to 5.5V                        | 6                            | 8         | < 3 m            | 2 Supplies                   |
| PCA9509A | Static Offset                        | Fm 0.8V LV VLT with current source         | 0.8 to 1.5V                     | 6                           | 2.3 to 5.5V                      | 6                            | 8         | < 3 m            | 2 Supplies                   |
| PCA9509P | Static Offset                        | Fm 0.8V LV VLT bus buffer                  | 0.8 to 1.5V                     | 6                           | 2.3 to 5.5V                      | 6                            | 8         | < 3 m            | 2 Supplies                   |
| PCA9515A | Static Offset                        | Fm bus repeater                            | 2.3 to 5.5V                     | 6                           | 2.3 to 5.5V                      | 6                            | 8         | On Card          | Over voltage tolerant        |
| PCA9516A | Static Offset                        | Fm 5-channel hub                           | 2.3 to 5.5V                     | 6                           | 2.3 to 5.5V                      | 6                            | 16        | On Card          | Over voltage tolerant        |
| PCA9517A | Static Offset                        | Fm 0.9V LV VLT bus repeater                | 0.9 to 5.5V                     | 6                           | 2.7 to 5.5V                      | 6                            | 8         | < 3 m            | 2 Supplies                   |

| Device   | Type of Capacitance Isolation Buffer | Description  | I <sup>2</sup> C-bus (V) (Left) | I <sub>ol</sub> (mA) (Left) | I <sup>2</sup> C-bus (V) (Right) | I <sub>ol</sub> (mA) (Right) | # of Pins | Typical Distance | Level Translation Capability |
|----------|--------------------------------------|--|---------------------------------|-----------------------------|----------------------------------|------------------------------|-----------|------------------|------------------------------|
| PCA9518A | Static Offset                        | Fm expandable 5-channel hub                              | 2.3 to 5.5V                     | 6                           | 2.3 to 5.5V                      | 6                            | 20        | On Card          | Over voltage tolerant        |
| PCA9519  | Static Offset                        | 4-channel version of PCA9509                             | 1 to 4V                         | 6                           | 3 to 5.5V                        | 6                            | 20        | < 3 m            | 2 Supplies                   |
| PCA9527  | Static Offset                        | Fm DDC VLT with accelerator and CEC                      | 2.7 to 5.5V                     | 6                           | 2.7 to 3.6V                      | 6                            | 14        | < 20 m           | 2 Supplies                   |
| PCA9600  | Static Offset                        | Fm+ HV for long distance and opto-isolation              | 2.6 to 15V                      | 3                           | 1.6 to 15V                       | 30                           | 8         | > 20 m           | Over voltage tolerant        |
| PCA9601  | Static Offset                        | Fm+ HV with stronger 15 mA local side drive              | 2.6 to 15V                      | 15                          | 1.6 to 15V                       | 30                           | 8         | > 20 m           | Over voltage tolerant        |
| PCA9617A | Static Offset                        | Fm+ 0.8V LV VLT bus repeater                             | 0.8 to 5.5V                     | 6                           | 2.2 to 5.5V                      | 6                            | 8         | < 3 m            | 2 Supplies                   |
| GTL2000  | None - FET                           | 22-bit Fm+ Voltage Level Translator                      | 1 to 5.5V                       | 64                          | 1 to 5.5V                        | 64                           | 48        | On Card          | Voltage Clamp                |
| GTL2002  | None - FET                           | 2-bit Fm+ Voltage Level Translator                       | 1 to 5.5V                       | 64                          | 1 to 5.5V                        | 64                           | 8         | On Card          | Voltage Clamp                |
| GTL2003  | None - FET                           | 8-bit Fm+ Voltage Level Translator                       | 1 to 5.5V                       | 64                          | 1 to 5.5V                        | 64                           | 20        | On Card          | Voltage Clamp                |
| GTL2010  | None - FET                           | 10-bit Fm+ Voltage Level Translator                      | 1 to 5.5V                       | 64                          | 1 to 5.5V                        | 64                           | 24        | On Card          | Voltage Clamp                |
| NVT2001  | None - FET                           | 1-bit Fm+ Voltage Level Translator                       | 1 to 5.5V                       | 64                          | 1 to 5.5V                        | 64                           | 6         | On Card          | Voltage Clamp                |
| NVT2002  | None - FET                           | 2-bit Fm+ Voltage Level Translator                       | 1 to 5.5V                       | 64                          | 1 to 5.5V                        | 64                           | 8         | On Card          | Voltage Clamp                |
| NVT2003  | None - FET                           | 3-bit Fm+ Level Translator for two power supply          | 1 to 5.5V                       | 64                          | 1 to 5.5V                        | 64                           | 10        | On Card          | Voltage Clamp                |
| NVT2004  | None - FET                           | 4-bit Fm+ Voltage Level Translator                       | 1 to 5.5V                       | 64                          | 1 to 5.5V                        | 64                           | 12        | On Card          | Voltage Clamp                |
| NVT2006  | None - FET                           | 6-bit Fm+ Voltage Level Translator                       | 1 to 5.5V                       | 64                          | 1 to 5.5V                        | 64                           | 16        | On Card          | Voltage Clamp                |
| NVT2008  | None - FET                           | 8-bit Fm+ Voltage Level Translator                       | 1 to 5.5V                       | 64                          | 1 to 5.5V                        | 64                           | 20        | On Card          | Voltage Clamp                |
| NVT2010  | None - FET                           | 10-bit Fm+ Voltage Level Translator                      | 1 to 5.5V                       | 64                          | 1 to 5.5V                        | 64                           | 24        | On Card          | Voltage Clamp                |
| PCA9306  | None - FET                           | Dual I <sup>2</sup> C/SMBus Fm+ Voltage Level Translator | 1 to 5.5V                       | 64                          | 1 to 5.5V                        | 64                           | 8         | On Card          | Voltage Clamp                |

## Got More Needs than Capability on your I<sup>2</sup>C-bus-based System?

Expand your reach with Bus Buffers from NXP.

Add more devices on the same system bus, extend the bus over longer distances, or isolate segments of the bus if necessary.

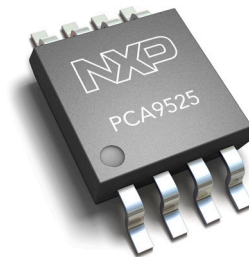

### PCA9525 BUS BUFFER FEATURES

- ▶ No offset allows communication with any other device and multiple devices in series.
- ▶ Impedance isolating buffer function for 2-wire buses
- ▶ Fast switching times for operation > 1MHz
- ▶ 4 mA maximum static open-drain, pull-down capability
- ▶ Input hysteresis for noise immunity
- ▶ Power supply operating voltage range of 2.7 V to 5.5 V



## Have Hot Insertion Needs for Your Backplane?

Plug NXP's PCA9522 Bus Buffer into live backplanes without causing data corruption.

Bring individual parts of your system on-line successively using the enable function, which supports bus section isolation.



### PCA9522 BUS BUFFER FEATURES

- ▶ Dual, bidirectional, unity gain, isolating buffering
- ▶ Hot insertion logic to prevent data and clock bus corruption in live backplane applications, specifically designed to support Advanced TCA applications
- ▶ Support for I<sup>2</sup>C-bus Standard- and Fast-modes
- ▶ Enable function to allow bus segments to be disconnected
- ▶ Low noise susceptibility
- ▶ Support for connection of several buffers in series
- ▶ Voltage level shift capability from 1.8 V to 10 V

## I<sup>2</sup>C-Controlled EEPROM, RAM and DIP Switches (multiplexed/latched EEPROMS)

Small-size serial memories (RAM and EEPROM) are common and have wide applicability for data storage.

The multiplexed/latched EEPROMs may be used as replacements for DIP switches or jumpers because the settings can be easily changed via the I<sup>2</sup>C-bus without having to power down equipment and open cabinets.

### Features

- Retain data during power-off (except RAM)
- Address and data transferred serially via the I<sup>2</sup>C-bus
- Built-in word address register automatically increments after each byte written or read (EEPROM)
- All bytes may be read in single operation (EEPROM)
- Up to 8 bytes can be written in one operation (EEPROM)

### Applications

- Meter readings
- Electronic key
- Product identification numbers
- Serial presence detect
- DIP Switches

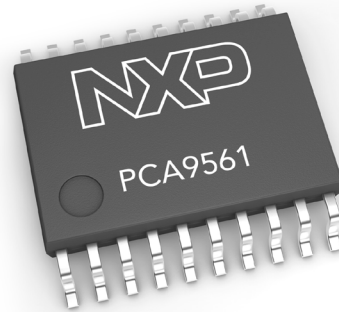

### I<sup>2</sup>C-Controlled RAM Selection Guide

| Device  | Power Supply | Address Pins | # of Blocks (256 bytes) | # of Bits | Temperature Range (°C) | Clock Frequency (kHz) |
|---------|--------------|--------------|-------------------------|-----------|------------------------|-----------------------|
| PCF8570 | 2.5-6 V      | 3            | 1                       | 2K        | -40 to +85             | 100                   |

### I<sup>2</sup>C-Controlled EEPROM Selection Guide

| Device      | Power Supply | Address Pins | # of Blocks (256 bytes) | # of Bits | Data Retention (Years) | Temperature Range (°C) | Clock Frequency (kHz) |
|-------------|--------------|--------------|-------------------------|-----------|------------------------|------------------------|-----------------------|
| PCF8582C-2  | 2.5-6 V      | 3            | 1                       | 2K        | 10                     | -40 to +85             | 100                   |
| PCF85103C-2 | 2.5-6 V      | 3            | 1                       | 2K        | 10                     | -40 to +85             | 100                   |
| PCF8594C-2  | 2.5-6 V      | 2            | 2                       | 4K        | 10                     | -40 to +85             | 100                   |
| PCA24508A   | 2.5-3.6 V    | 0            | 8 (128 Bytes)           | 8K        | 10                     | -40 to +85             | 400                   |
| PCA9500     | 2.5-3.6 V    | 3            | 1                       | 2K        | 10                     | -40 to +85             | 400                   |
| PCA9501     | 2.5-3.6 V    | 6            | 1                       | 2K        | 10                     | -40 to +85             | 400                   |

### I<sup>2</sup>C-Controlled DIP Switches (Multiplexed/latched EEPROM) Selection Guide

| Device  | # of Pins | # of Non-volatile Registers | # of Register Bits | # of Hardware Input Pins | # of Multiplexed Outputs | Non-Multiplexed Inputs | Data Retention | Temperature Range (°C) | Clock Frequency (kHz) |
|---------|-----------|-----------------------------|--------------------|--------------------------|--------------------------|------------------------|----------------|------------------------|-----------------------|
| PCF8550 | 15        | 1                           | 5                  | 4                        | 4                        | Yes                    | 10             | 0 to 70                | 400                   |
| PCA9558 | 28        | 1                           | 6                  | 5                        | 5                        | Yes                    | 10             | 0 to 70                | 400                   |
| PCA9559 | 20        | 1                           | 6                  | 5                        | 5                        | Yes                    | 10             | 0 to 70                | 400                   |
| PCA9560 | 20        | 2                           | 6                  | 5                        | 5                        | Yes                    | 10             | 0 to 70                | 400                   |
| PCA9561 | 20        | 4                           | 6                  | 6                        | 6                        | No                     | 10             | 0 to 70                | 400                   |

## Still Opening Cabinets and Powering Down Equipment to Change Manual Switches?

Move to I<sup>2</sup>C configurable, non-volatile memory controlled settings with NXP's EEPROM DIP switches.

Set these switches easily via the I<sup>2</sup>C-bus, controlled by the system microprocessor.

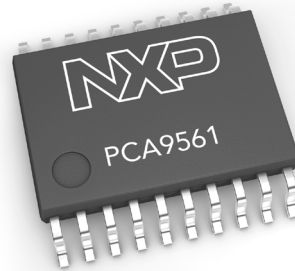

### PCA9561 EEPROM DIP SWITCH FEATURES

- ▶ 6-bit 5-to-1 multiplexer DIP switch
- ▶ 400 kHz maximum clock frequency
- ▶ Operating supply voltage of 3.0 V to 3.6 V
- ▶ 5 V and 2.5 V tolerant inputs/outputs
- ▶ Selection of non-volatile registers via I<sup>2</sup>C-bus

## Intelligent Stepper Motor Controller

The PCA9629 provides all the logic and control required to drive a four-phase stepper motor via the I<sup>2</sup>C-bus.

### Features

- Generate motor coil drive phase sequence signals with four outputs for use with external high current drivers to off-load CPU
- Four balanced push-pull type outputs capable of sinking 25 mA or sourcing 25 mA for glueless connection to external high current drivers needed to drive motor coils
- Up to 1000 pF loads with 100 ns rise and fall times
- Sensor enabled drive control: linked to interrupt from I/O pins
- Direction control of motor shaft
- Selectable active hold, power off or released states for motor shaft
- Four general purpose I/Os:
  - Configured to sense logic level outputs from optical interrupter photo transistor circuit
  - Configured as outputs to drive (source/sink) LEDs or other loads up to 25 mA
  - Programmable interrupt Mask Control for input pins
- Package offered: TSSOP16

### Applications

- Car mirror control
- Automated door windows
- Printers
- Scanners
- Toys
- Robotics

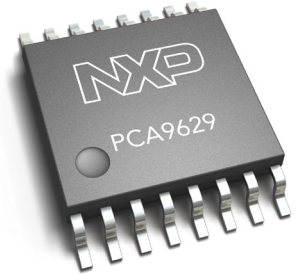

## Stepper Motor Control Doesn't Have to Consume Valuable Microprocessor Cycles.

NXP's I<sup>2</sup>C-bus controlled, low-power-consumption stepper motor controller provides highly flexible operation.

Control step size, number of steps per command, number of rotations, direction of rotation and more, all via I<sup>2</sup>C programmable control registers.

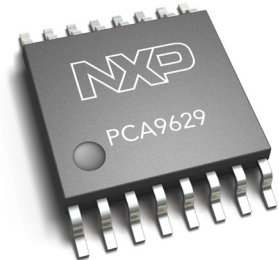

### PCA9629 STEPPER MOTOR FEATURES



- ▶ 1 MHz Fast-mode Plus (Fm+) I<sup>2</sup>C-bus operation
- ▶ Built-in oscillator requires no external components
- ▶ Four balanced push-pull type outputs capable of sinking or sourcing 25 mA
- ▶ Drive capability of up to 1000 pF loads with 100 ns rise and fall times
- ▶ Programmable step rate of 344.8 kpps to 0.3 pps with ±5% accuracy
- ▶ Programmable rotation control
- ▶ Programmable watchdog timer
- ▶ Four general purpose I/O for sensing and signaling functions
- ▶ -40 °C to +85 °C operation

## Bridge Integrated Circuits and Bus Controllers

Bridge integrated circuits allow designers to connect together devices that use different serial buses. Bus controllers serve as interfaces between most standard parallel bus microcontrollers/microprocessors and the serial I<sup>2</sup>C-bus, and allow bidirectional communication between the parallel bus and the I<sup>2</sup>C-bus.

### Features

- Operate at low voltages
- Consume little power
- Come in a variety of ultra-small package types

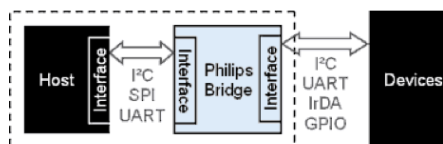

### Applications

- Host processor communication with disparate serial, wireless, and GPIO interfaces

## Bridge Integrated Circuits Selection Guide

| Device     | Bridge Type                              | UARTs | GPIO | IrDA SIR Speed (Maximum) | SPI Speed (Maximum) | FIFO (Bytes) | Oscillator |
|------------|--|-------|------|--------------------------|---------------------|--------------|------------|
| SC16IS740  | I <sup>2</sup> C/SPI Slave to UART       | 1     | 0    | 115.2 Kbps               | 4                   | 64           |            |
| SC16IS741  | I <sup>2</sup> C/SPI Slave to UART       | 1     |      | 115.2 Kbps               |                     | 64           |            |
| SC16IS750  | I <sup>2</sup> C/SPI Slave to UART       | 1     | 8    | 115.2 Kbps               | 4                   | 64           |            |
| SC16IS752  | I <sup>2</sup> C/SPI Slave to UART       | 2     | 8    | 115.2 Kbps               | 4                   | 64           |            |
| SC16IS760  | I <sup>2</sup> C/SPI Slave to UART       | 1     | 8    | 1.152 Mbps               | 15                  | 64           |            |
| SC16IS762  | I <sup>2</sup> C/SPI Slave to UART       | 2     | 8    | 1.152 Mbps               | 15                  | 64           |            |
| SC16IS850L | 1.8V I <sup>2</sup> C/SPI Slave to UART  | 1     |      | 115.2 Kbps               |                     | 128          |            |
| SC18IS600  | SPI Slave to I <sup>2</sup> C Master     |       | 4    |                          | 1                   |              | Internal   |
| SC18IS601  | SPI Slave to I <sup>2</sup> C Master     |       | 3    |                          | 3                   |              | External   |
| SC18IS602B | I <sup>2</sup> C/SPI Slave to SPI Master |       | 4    |                          | 1.8 Mbps            |              | Internal   |
| SC18IM700  | UART to I <sup>2</sup> C Master          |       | 8    |                          |                     |              |            |

## Bus Controllers Selection Guide

| Device   | Type  | Voltage Range (V)               | Maximum I <sup>2</sup> C Frequency (kHz) | Clock Source       | Parallel Interface       | Package                                 |
|----------|---|---------------------------------|--|--------------------|--------------------------|---|
| PCA9564  | Parallel bus to I <sup>2</sup> C-bus controller               | 2.3 to 3.6 with 5V tolerance    | 360                                      | Internal           | Fast                     | DIL-20<br>SO-20<br>TSSOP-20<br>HVQFN-20 |
| PCA9661  | Parallel bus to 1 channel Fm+ I <sup>2</sup> C-bus controller | 3 to 3.6V core<br>3 to 5.5V I/O | 1000                                     | Internal (trimmed) | Fast with 4k Byte Buffer | LQFP48                                  |
| PCA9663  | Parallel bus to 3 channel Fm+ I <sup>2</sup> C-bus controller | 3 to 3.6V core<br>3 to 5.5V I/O | 1000                                     | Internal (trimmed) | Fast with 4k Byte Buffer | LQFP48                                  |
| PCA9665  | Fm+ parallel bus to I <sup>2</sup> C-bus controller           | 2.3 to 3.6 with 5V tolerance    | 1000                                     | Internal (trimmed) | Fast with 68 Byte Buffer | SO-20<br>TSSOP-20<br>HVQFN-20           |
| PCA9665A | Fm+ parallel bus to I <sup>2</sup> C-bus controller           | 2.3 to 3.6 with 5V tolerance    | 1000                                     | Internal (trimmed) | Fast with 68 Byte Buffer | TSSOP-20                                |
| PCF8584  | I <sup>2</sup> C-bus controller                               | 4.5 to 5.5                      | 90                                       | External           | Slow                     | DIP-20<br>SO-20                         |
| PCU9661  | Parallel bus to 1 channel UFm I <sup>2</sup> C-bus controller | 3 to 3.6V core<br>3 to 5.5V I/O | 5000                                     | Internal (trimmed) | Fast with 4k Byte Buffer | LQFP48                                  |



| Device  | Type   | Voltage Range (V)                | Maximum I <sup>2</sup> C Frequency (kHz) | Clock Source       | Parallel Interface       | Package |
|---------|--|----------------------------------|--|--------------------|--------------------------|---------|
| PCU9668 | Parallel bus to 2 channel Fm+ and 1 channel U <sup>F</sup> m I <sup>2</sup> C-bus controller | 3 to 3.6V core<br>3 to 5.5 V I/O | 5000                                     | Internal (trimmed) | Fast with 4k Byte Buffer | LQFP48  |
| PCU9669 | Parallel bus to 1 channel Fm+ and 2 channel U <sup>F</sup> m I <sup>2</sup> C-bus controller | 3 to 3.6V core<br>3 to 5.5 V I/O | 5000                                     | Internal (trimmed) | Fast with 4k Byte Buffer | LQFP48  |

## Transmitting Large Amounts of Serial Data?

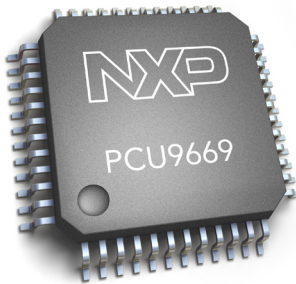

NXP's advanced single master mode I<sup>2</sup>C-bus controller supports 8-bit parallel bus to I<sup>2</sup>C-bus protocol conversion.

Designed specifically for data intensive I<sup>2</sup>C-bus transfers.

### PCU9669 BUS CONTROLLER FEATURES

- ▶ Parallel bus to I<sup>2</sup>C-bus protocol conversion
- ▶ 5 Mbit/s unidirectional data transfer on Ultra Fast-mode (U<sup>F</sup>m) channel (push-pull driver)
- ▶ 1 Mbit/s and up to 30 mA SCL/SDA I<sub>OL</sub> Fast-mode Plus (Fm+) capability
- ▶ Individual 4352-byte buffers for the Fm+ and U<sup>F</sup>m channels for a total of 13056 bytes of buffer space
- ▶ Internal oscillator trimmed to 1% accuracy to reduce external component requirements
- ▶ SCL clock stretching support (Fm+ only)
- ▶ Operating supply voltage of 3.0 V to 3.6 V
- ▶ I<sup>2</sup>C-bus I/O supply voltage of 3.0 V to 5.5 V

## Blinkers, Dimmers, Drivers (LED Controllers)

Designers commonly use LED controllers/drivers for blinking, dimming, and color mixing LEDs in I<sup>2</sup>C, SMBus, IPMI and PMbus applications. Using separate I<sup>2</sup>C LED controllers limits bus traffic and frees the I<sup>2</sup>C master for other purposes.

### Features

- Any bits not used to drive an LED can be used as normal GPIO (Dimmers/Blinkers)
- Industrial operating temperature range
- Low standby current
- Offered in a variety of package types

### Applications

- Operating number displays such as 7-segment block
- Driving photo flash LED in mobile phones and PDAs



### LED Dimmers/Blinkers Selection Guide

| Device  | # bits | Type       | Feature                  | Bus              |
|---------|--------|------------|--------------------------|------------------|
| PCA9530 | 2      | LED Dimmer | Programmable brightness  | I <sup>2</sup> C |
| PCA9531 | 8      | LED Dimmer | Programmable brightness  | I <sup>2</sup> C |
| PCA9532 | 16     | LED Dimmer | Programmable brightness  | I <sup>2</sup> C |
| PCA9533 | 4      | LED Dimmer | Programmable brightness  | I <sup>2</sup> C |
| PCA9550 | 2      | LED Driver | Programmable blink rates | I <sup>2</sup> C |
| PCA9551 | 8      | LED Driver | Programmable blink rates | I <sup>2</sup> C |
| PCA9552 | 16     | LED Driver | Programmable blink rates | I <sup>2</sup> C |
| PCA9553 | 4      | LED Driver | Programmable blink rates | I <sup>2</sup> C |

### LED Segment Drivers Selection Guide

| Device  | Feature            |
|---------|--------------------|
| SAA1064 | 4-digit LED driver |

### LED Flash Drivers Selection Guide

| Device   | Feature  |
|----------|--|
| SSL3250A | Dual LED 500mA Flash driver with Torch and Indicator Modes |
| SSL3252  | Dual LED 500mA Flash driver with Torch and Indicator Modes |

### LED RGB Color Mixers Selection Guide

| Device  | # channels | Feature                         | Bus                  |
|---------|------------|---------------------------------|----------------------|
| PCA9622 | 16         | 100mA 40V                       | Fm+ I <sup>2</sup> C |
| PCA9624 | 8          | 100mA 40V                       | Fm+ I <sup>2</sup> C |
| PCA9626 | 24         | 100mA 40V                       | Fm+ I <sup>2</sup> C |
| PCA9632 | 4          | Low power                       | Fm+ I <sup>2</sup> C |
| PCA9633 | 4          | Optimized for RGBA color mixing | Fm+ I <sup>2</sup> C |
| PCA9634 | 8          | Optimized for RGBA color mixing | Fm+ I <sup>2</sup> C |
| PCA9635 | 16         | Optimized for RGBA color mixing | Fm+ I <sup>2</sup> C |
| PCA9685 | 16         | PWM LED controller              | Fm+ I <sup>2</sup> C |
| PCU9654 | 8          | 100mA 40V                       | UFm I <sup>2</sup> C |
| PCU9655 | 16         | 100mA 40V                       | UFm I <sup>2</sup> C |
| PCU9656 | 24         | 100mA 40V                       | UFm I <sup>2</sup> C |
| PCA9955 | 16         | 57 mA constant current          | UFm I <sup>2</sup> C |
| PCA9952 | 16         | 57 mA constant current          | Fm+ I <sup>2</sup> C |
| PCA9955 | 16         | 57 mA constant current          | Fm+ I <sup>2</sup> C |

## Add Pizzazz to Your Product with NXP's Highly Configurable LED Drivers



Control blinking and dimming of RGBA LEDs to support status, display, backlight, or amusement functions.

### PCA9955 LED DRIVER FEATURES

- ▶ 16 LED drivers, each programmable for brightness, dimming/blinking modes, and on/off states
- ▶ 1 MHz Fast-mode Plus (Fm+) compatible I<sup>2</sup>C-bus interface
- ▶ Four hardware addressable pins to support 16 devices connected to the same I<sup>2</sup>C-bus
- ▶ 8 MHz internal oscillator requiring no external components
- ▶ 256-step programmable brightness, group brightness, and group blinking
- ▶ Operating supply voltage of 3 V to 5.5 V
- ▶ -20 °C to +85 °C operation

## Capacitive Sensors

The PCA8885 and PCF8885 integrated circuits are capacitive 8-channel proximity switches that use a patented method to detect a change in capacitance on remote sensing plates.

### Features

- Dynamic proximity switch with 8 sensor channels
- Support for matrix arrangement of sensors
- Sensing plates can be connected remotely
- Adjustable response time
- Adjustable sensitivity
- Continuous auto-calibration
- Digital processing method
- Direct and latching switch modes
- AEC-Q100 compliant version available for automotive applications
- I<sup>2</sup>C Fast-mode Plus (Fm+) compatible interface
- Two I<sup>2</sup>C-bus addresses
- Cascading of two ICs possible
- Interrupt signaling over I<sup>2</sup>C-bus
- Interrupt output
- Wide voltage operating range ( $V_{DD} = 2.5\text{ V to }5.5\text{ V}$ )
- Sleep mode ( $I_{DD} < 100\text{ nA}$ )
- Low-power battery operation possible ( $I_{DD} \sim 10\text{ }\mu\text{A}$ )
- Operating temperature range ( $T_{amb} = -40\text{ }^{\circ}\text{C to }+85\text{ }^{\circ}\text{C}$ )
- Available in TSSOP28 and SOIC28 package

### Applications

- Replacing mechanical switches
- Hermetically sealed keys on a keyboard
- Switches for medical applications
- Touch switch in front of LCD display
- Audio control: on/off, channel, and volume
- User interface and vandal-proof switches
- Switches in or under upholstery, leather, handles, mats, carpets, tiles and glass
- Use of standard metal sanitary parts (for example, a tap) as switch
- Portable communication and entertainment units
- White goods control panel

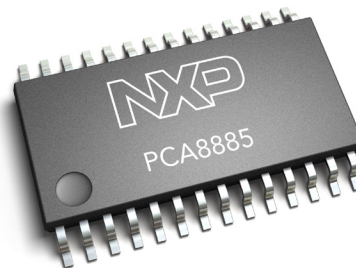

### Capacitive Sensor Selection Guide

| Device  | Voltage Range (V) | Input Capacitive Range (pF) | Sensor Channels | Temperature Range (°C) | I <sup>2</sup> C Interface | AEC-Q100 Compliant | Package         |
|---------|-------------------|-----------------------------|-----------------|------------------------|----------------------------|--------------------|-----------------|
| PCA8885 | 2.5–5.5           | 10–40                       | 8               | -40 to +85             | Fm+                        | ✓                  | TSSOP28, SOIC28 |
| PCF8885 | 2.5–5.5           | 10–40                       | 8               | -40 to +85             | Fm+                        |                    | TSSOP28, SOIC28 |
| PCF8883 | 3–9               | 10–60                       | 1               | -40 to +85             | 1 interrupt                |                    | SO8, CSP        |
| PCA8886 | 3–9               | 10–60                       | 2               | -40 to +85             | 2 interrupts               | ✓                  | TSSOP16         |

## Up Your Product's "Cool" Factor

Replace mechanical switches with NXP's capacitive touch and proximity sensors.

Add switches in or under upholstery, leather, handles, mats, carpets, tiles, and glass.

Ideal for use in hermetically sealed keyboard keys, medical applications switches, hazardous environment switches, white goods control, and more.

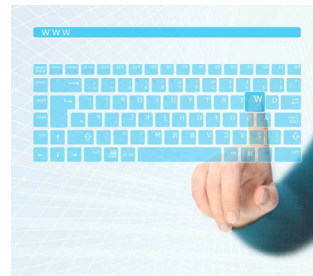

### **PCA8885 CAPACITIVE TOUCH AND PROXIMITY SENSOR FEATURES**

- ▶ AEC-Q100 compliance for automotive applications
- ▶ Dynamic touch and proximity sensor with 8 sensor channels
- ▶ Support for remote connectivity to sensing plates
- ▶ Adjustable sensitivity with continuous auto-calibration
- ▶ I<sup>2</sup>C Fast-mode Plus (Fm+) compatible interface
- ▶ Operating voltage range of 2.5 V to 5.5 V
- ▶ -40 °C to +85 °C operations

## Demo Boards

NXP offers a wide variety of supporting demonstration and evaluation boards, making it easy to program new peripherals and learn about the I<sup>2</sup>C-bus protocol.

| Product                           | Description   |
|-----------------------------------|---|
| <b>OM6270</b>                     | SPI/ I <sup>2</sup> C-to-UART bridge demonstration board (SC16IS750)                              |
| <b>OM6271</b>                     | SPI-to-I <sup>2</sup> C-master bridge demonstration board (SC18IS600)                             |
| <b>OM6272</b>                     | UART-to-I <sup>2</sup> C-master bridge demonstration board (SC18IM700)                            |
| <b>OM6273</b>                     | SPI/ I <sup>2</sup> C-to-DUART/IrDA/GPIO demonstration board (SC16IS752)                          |
| <b>OM6274</b>                     | I <sup>2</sup> C-to-SPI-master bridge demonstration board (SC18IS602)                             |
| <b>OM6275</b>                     | I <sup>2</sup> C 2005-1 evaluation board  |
| <b>OM6276</b>                     | PCA9633 demonstration board   |
| <b>OM6277</b>                     | PCA9564 evaluation board  |
| <b>OM6278</b>                     | I <sup>2</sup> C 2002-1A evaluation board   |
| <b>OM6281</b>                     | PCA9698 daughter card for I <sup>2</sup> C 2005-1   |
| <b>OM6282</b>                     | PCA9633 daughter card for I <sup>2</sup> C 2005-1   |
| <b>OM6285</b>                     | I <sup>2</sup> C 2002-1A evaluation board without PC controller board                             |
| <b>OM6290</b>                     | LCD driver evaluation board: PCF8576D, PCF2119, PCF8531, PCA9633                                  |
| <b>OM6292</b>                     | PCA21125, PCF8562 demonstration board   |
| <b>OM6293</b>                     | PCA9600 daughter card for I <sup>2</sup> C 2005-1   |
| <b>OM6297</b>                     | PCF2123, PCF8562 demonstration board  |
| <b>OM11051</b>                    | PCF2127A demonstration board  |
| <b>OM11056</b>                    | PCA8885/PCF8885 evaluation board  |
| <b>OM11057</b><br><b>OM11057A</b> | PCF8885/86 capacitive sensor and PCF8536 LCD/ LED driver<br>OM11057A with high sensitivity slider |
| <b>OM13260</b>                    | I <sup>2</sup> C Fm+ development board (RoHS)   |
| <b>OM13285</b>                    | PCA9629 demonstration board   |
| <b>OM13303</b>                    | GPIO target board (RoHS)  |
| <b>OM13320</b>                    | I <sup>2</sup> C Fm+ development kit (RoHS)   |
| <b>OM13398</b>                    | PCA9617A bus buffer board   |
| <b>OM13399</b>                    | Bridge board  |

OM6275  
I<sup>2</sup>C 2005-1 evaluation board

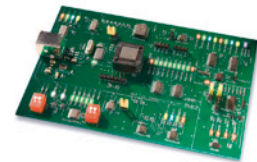

OM6278  
I<sup>2</sup>C 2002-1A evaluation board



OM6277  
PCA9564 evaluation board

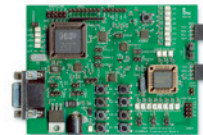

OM6293  
PCA9600 daughter card for I<sup>2</sup>C 2005-1



OM6276  
PCA9633 demo board



OM13320 Fm+ Demonstration Kit which includes the OM13260 Fm+ Development Board with two OM13303 GPIO Target Boards and one each of the OM13398 PCA9617A bus buffer and OM13399 bridge board

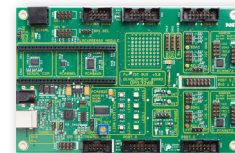

OM13285 PCA9629 stepper motor demonstration board

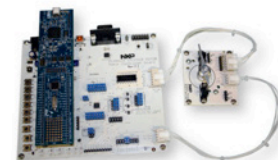

OM11057 PCF8885/86 touch switch with PCF8536 LCD/LED driver



## Resources

### Frequently Asked Questions

**Question: Does the presence of Standard Mode devices preclude 1Mbps transfers between Fm+ devices?**

**Answer:** NXP's Fm+ parts are backward compatible, but a system containing a mix of Standard Mode, Fm, and Fm+ parts can only be operated at the speed of the slowest part, so if maximum speed is desired, it is necessary to segregate different speed grade functions onto different I<sup>2</sup>C-buses.

---

**Question: If an I<sup>2</sup>C slave device isn't responding, what are the possible reasons?**

**Answer:** If an I<sup>2</sup>C slave device doesn't respond properly, it may be because there was an I<sup>2</sup>C protocol violation, or fewer than 8 bits were written to the slave. Also consider that the address could be wrong, the device isn't powered up or it is in reset mode.

---

**Question: What does quasi-bidirectional data pins mean? Why do you use quasi?**

**Answer:** Port pins may be described as "quasi-" bidirectional because they are not ALWAYS bidirectional. The "quasi" means "sometimes" bidirectional. They are bidirectional only when in their default or reset state, or when they are written as HIGH. In this situation, they are internally pulled high by a weak pull-up current and they can be pulled LOW by an external signal when they are being used as an input. Port pins may also be driven high by an external signal. If any port pins are written as LOW, then those pins become unidirectional outputs and they cannot be used as inputs. The quasi bi-directional devices are very to easy to program.

---

**Question: Can we create a protocol-based bus recovery mechanism using signal toggles for our host I<sup>2</sup>C path if the I<sup>2</sup>C state machine gets hung in the middle of transmitting a byte of data back to the host?**

**Answer:** Bit toggling should work to recover a hung I<sup>2</sup>C-bus, especially if the design uses NXP microprocessors and I<sup>2</sup>C devices. Send out nine clock pulses rather than examining the SDA pin. This approach should guarantee that the slave removes itself from the bus.

---

**Question: What does remote I/O expander mean?**

**Answer:** Remote I/O expander means the I/O expander is an external chip. It is like any I/O expander in terms of its application and function.

---

**Question: Can I place masters on either side of an I<sup>2</sup>C multiplexer?**

**Answer:** I<sup>2</sup>C multiplexer/switches are very simple devices that are controlled by a master located on the upstream side. If all of the masters in the system (upstream and downstream of the multiplexer/switches) are multi-master capable, then it is safe to place them on either side of a multiplexer/switches, but the downstream masters are isolated when the channel is open since they have no access to the multiplexer/switch state machine.

---

**Question: How should an unused /RESET pin be terminated?**

**Answer:** An unused /RESET pin needs to be connected to Vcc either directly or through a resistor to limit current if there is a fault.

---

**Question: How should an unused /INT pin be terminated?**

**Answer:** An unused /INT pin may be connected to GND or left unconnected since it is an open drain output.

---



### Website Product Information

**I<sup>2</sup>C-bus websites:** [www.nxp.com/interface](http://www.nxp.com/interface) and [http://www.nxp.com/products/interface\\_and\\_connectivity/i2c](http://www.nxp.com/products/interface_and_connectivity/i2c)  
NXP's I<sup>2</sup>C-bus websites are a valuable resource for device information and support. They provide direct access to comprehensive product literature, such as brochures, datasheets, application notes, presentations, packaging information, and more.

**I<sup>2</sup>C-bus support:** <http://ics.nxp.com/support/>

Visit the I<sup>2</sup>C-bus support page for manuals, FAQs, information about evaluation kits, tools and training materials, links to application and design support, and more.

**Packaging Information:** <http://ics.nxp.com/packaging/>

Visit the I<sup>2</sup>C-bus packaging page for technical information about NXP package options.

### Videos

[www.youtube.com/nxpinterface](http://www.youtube.com/nxpinterface)

## Contact Information

### Corporate Headquarters:

NXP Semiconductors  
Corporate Communications & Branding  
High Tech Campus 60  
5656 AG Eindhoven  
The Netherlands  
Fax: +31 40 27 26533

### North America:

NXP Semiconductors  
411 E. Plumeria Drive  
San Jose, CA 95134, USA

### Technical Support and Sales

Technical Support: <http://www.nxp.com/technicalsupport/>

For sales offices and distributors, please visit: [www.nxp.com/contact](http://www.nxp.com/contact)

### Notices

© 2013 NXP Semiconductors N.V.  
All rights reserved.

Reproduction in whole or in part is prohibited without the prior written consent of the copyright owner. The information presented in this document does not form part of any quotation or contract, is believed to be accurate and reliable and may be changed without notice.

No liability will be accepted by the publisher for any consequence of its use. Publication thereof does not convey nor imply any license under patent- or other industrial or intellectual property rights.

Date of release: May 2013  
Document order number: 12NC: 9397 750 17443

---

# Mouser Electronics

Authorized Distributor

Click to View Pricing, Inventory, Delivery & Lifecycle Information:

[NXP:](#)

[OM13320,598](#)