

GPS Active Internal Patch

APAM1368YB13V3.0

RoHS/RoHS II compliant

MSL level: N/A



13.0 x 13.0 x 6.8mm

FEATURES:

- Compact Size
- Easy to Install
- RoHS Compliant

TYPICAL APPLICATIONS:

- Automotive Navigation, Marine buoys
- Personal Tracking
- Surveying equipment, Cell phone, Laptop
- Healthcare and medical monitoring devices, PND, PDA

STANDARD SPECIFICATIONS:

Antenna

Parameters	Min.	Typ.	Max.	Units	Note
Center Frequency	1575.42± 1.02			MHz	
Bandwidth	5			MHz	
Gain		1.0		dBic	(Peak gain on 70*70mm Ground Plane facing Zenith.)
VSWR @ Center Frequency		1.5			
Polarization Model	RHCP				(Right Hand Circular Polarization)
Impedance	50			Ω	
Working Temperature	-25		+72	°C	
Storage Temperature	-45		+85	°C	

Low Noise Amplifier (LNA)

Parameters	Min.	Typ.	Max.	Units	Note
Center Frequency	1575.42± 1.02			MHz	
DC Voltage	2.70		3.30	V	
Gain		19		dB	(Without cable +25°C± 10°C)
Output VSWR		1.5			
Noise Figure		1.3			(+25°C± 10°C)
DC current		3.5		mA	(At 3.0V)

SMITH CHART

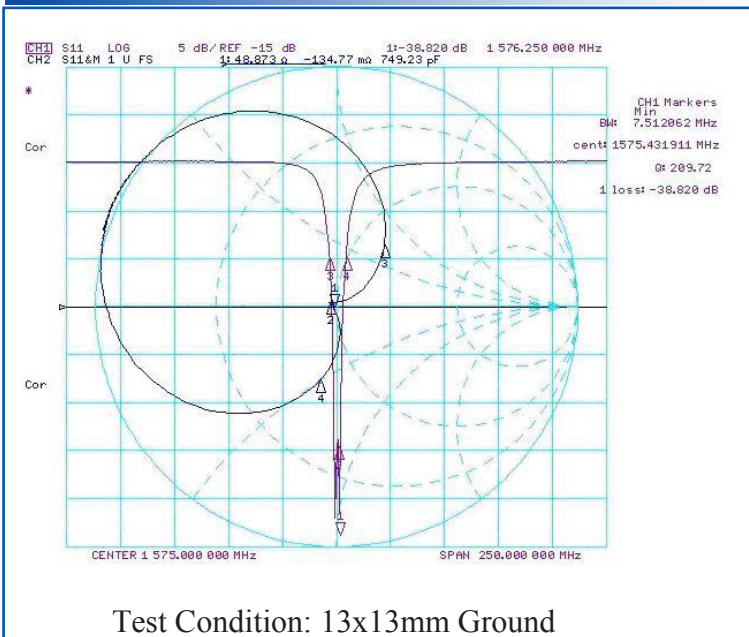

GPS LNA GAIN PLOT

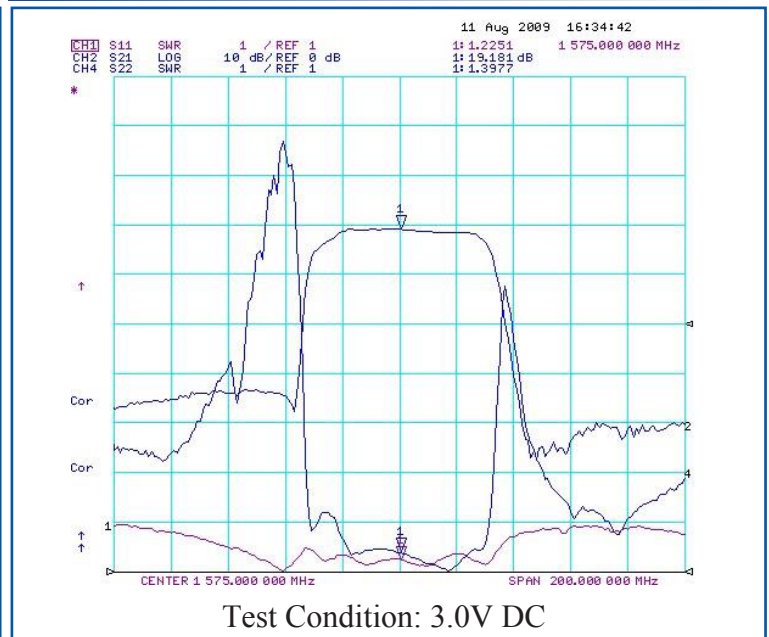

GPS Active Internal Patch

APAM1368YB13V3.0

RoHS/RoHS II compliant

MSL level: N/A



OUTLINE DIMENSION:

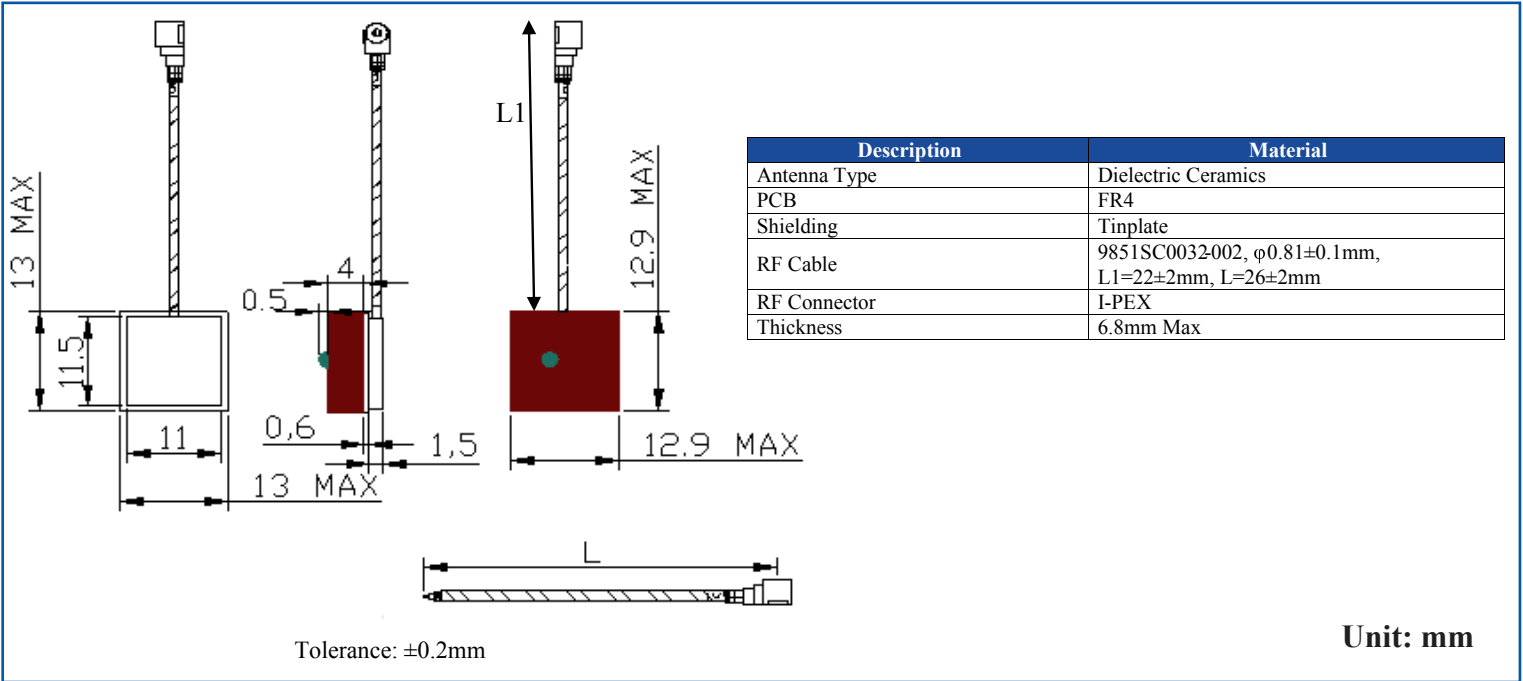

PACKAGING

Package Type	Quantity
MOQ	250 pcs
Tray	50 pcs/tray
Vacuum	5 trays per Vacuum bag (250pcs per bag)
Outer Box	4 bags = 1000 pcs/carton

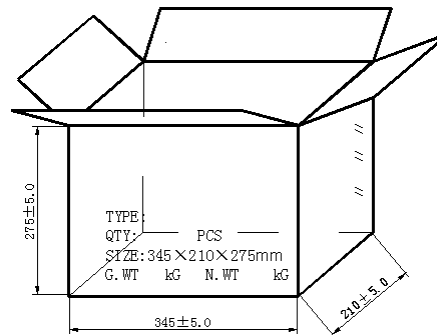
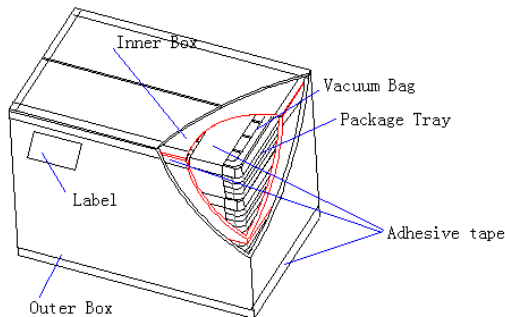
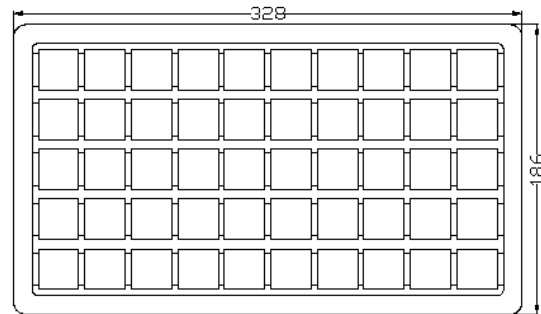

The GPS antenna 50 pcs are packed per tray, 5 trays are packed per vacuum bag, 4 vacuum bags per carton, and 1000 pcs GPS antenna per carton. The size of each carton is 345*210*275mm.

ATTENTION: Abracon LLC's products are COTS – Commercial-Off-The-Shelf products; suitable for Commercial, Industrial and, where designated, Automotive Applications. Abracon's products are not specifically designed for Military, Aviation, Aerospace, Life-dependant Medical applications or any application requiring high reliability where component failure could result in loss of life and/or property. For applications requiring high reliability and/or presenting an extreme operating environment, written consent and authorization from Abracon LLC is required. Please contact Abracon LLC for more information.

Mouser Electronics

Authorized Distributor

Click to View Pricing, Inventory, Delivery & Lifecycle Information:

[ABRACON:](#)

[APAM1368YB13V3.0](#)